

ASSEMBLY INSTRUCTIONS

Description: QUEEN BED

Thank you for purchasing this quality product. Be sure to check all packing material carefully for small parts that may have come loose inside the carton during shipment.

Step1: Assembly HB(A),FB(B) with Leg(F).

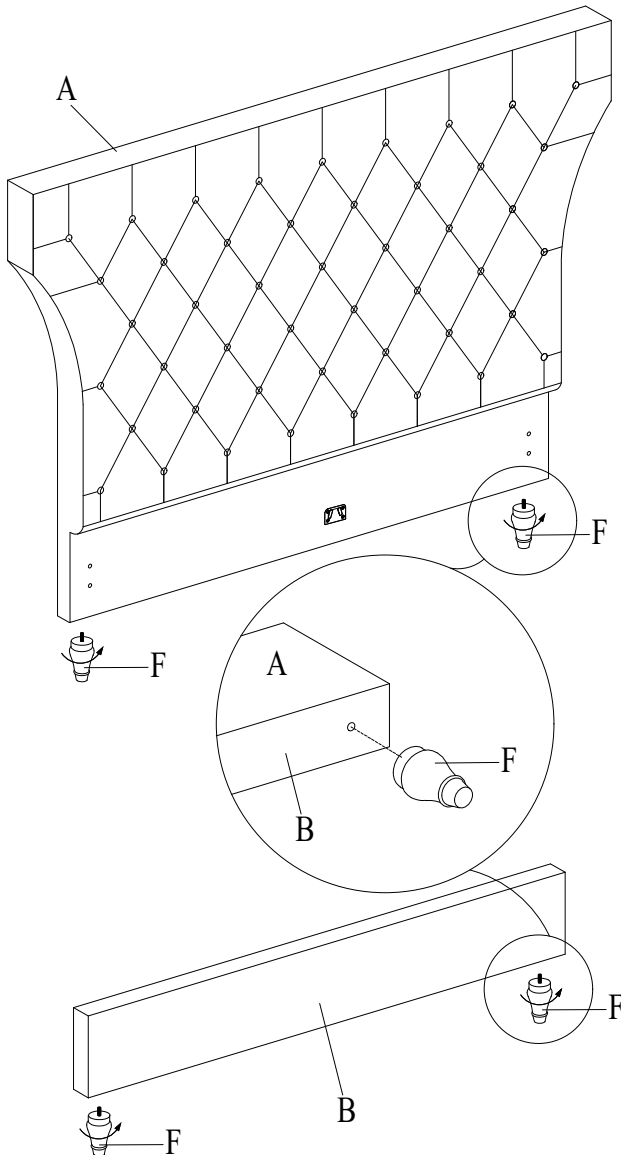

TOOLS REQUIRED(NOT PROVIDED)

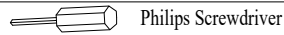

Philips Screwdriver

PARTS LIST:

No.	Description	Sketch	Quantity
A	Headboard		1 PC
B	Footboard		1 PC
C	Side Rail		2PCS
D	Center Rail		1 PC
E	Center Rail Support Leg		3PCS
F	Leg		4PCS
G	Slats		1SET

HB HARDWARE LIST: (2) LEG FOR HEADBOARD

No.	Description	Sketch	Size	Quantity
H	Bolt		Ø5/16"*2-1/2"	4PCS
J	Allen Key		M4*2"	1PC
K	Spring Washer		Ø5/16"	4PCS
L	Flat Washer		Ø5/16"	8PCS
N	Spanner		M12	1PC
O	Nut		M8	4PCS

FB HARDWARE LIST: (2) LEG FOR FOOTBOARD

No.	Description	Sketch	Size	Quantity
I	Bolt		Ø5/16"*1-1/2"	7PCS
J	Allen Key		M4*2"	1PC
K	Spring Washer		Ø5/16"	4PCS
L	Flat Washer		Ø5/16"	7PCS
M	Screw		Ø8*1"	28PCS

F	Leg		4PCS
---	-----	--	------

ASSEMBLY INSTRUCTIONS

Description: QUEEN BED

Thank you for purchasing this quality product. Be sure to check all packing material carefully for small parts that may have come loose inside the carton during shipment.

Step2: Assembly Side Rail(C) with HB(A)&FB(B).

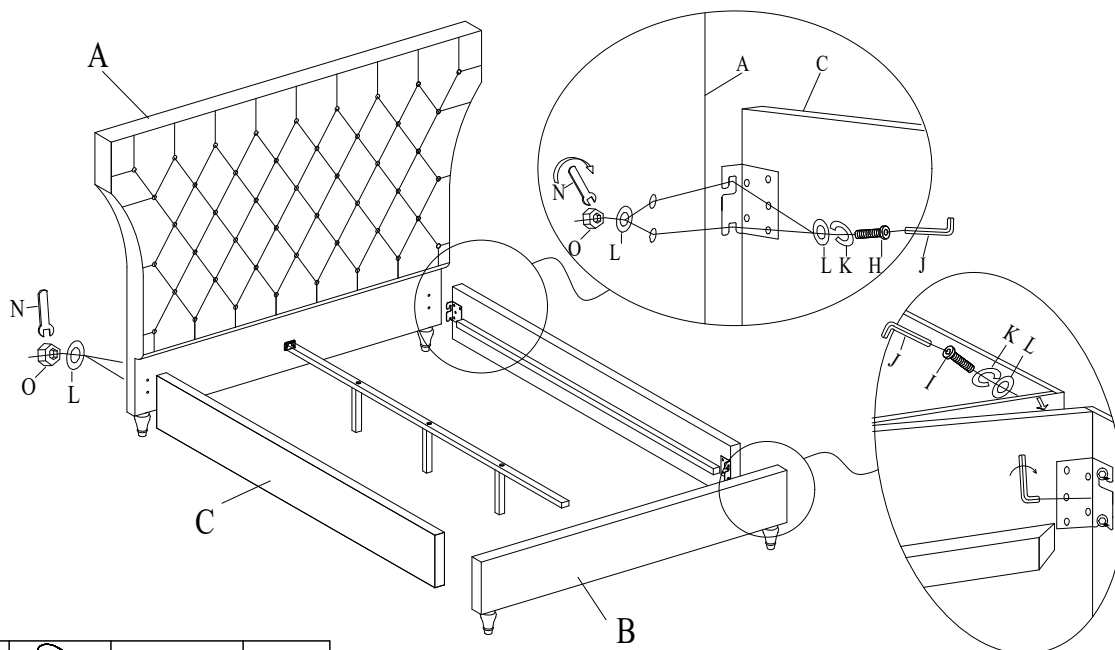

L	Flat Washer		Ø5/16"	12PCS
K	Spring Washer		Ø5/16"	8PCS
N	Spanner		M12	1PC
O	Nut		M8	4PCS

H	Bolt		5/16"*2-1/2"	4PCS
I	Bolt		5/16"*1-1/2"	4PCS
J	Allen Key		M4*2"	1PC

Step3: Assembly Center Rail(D) with HB(A)&FB(B).

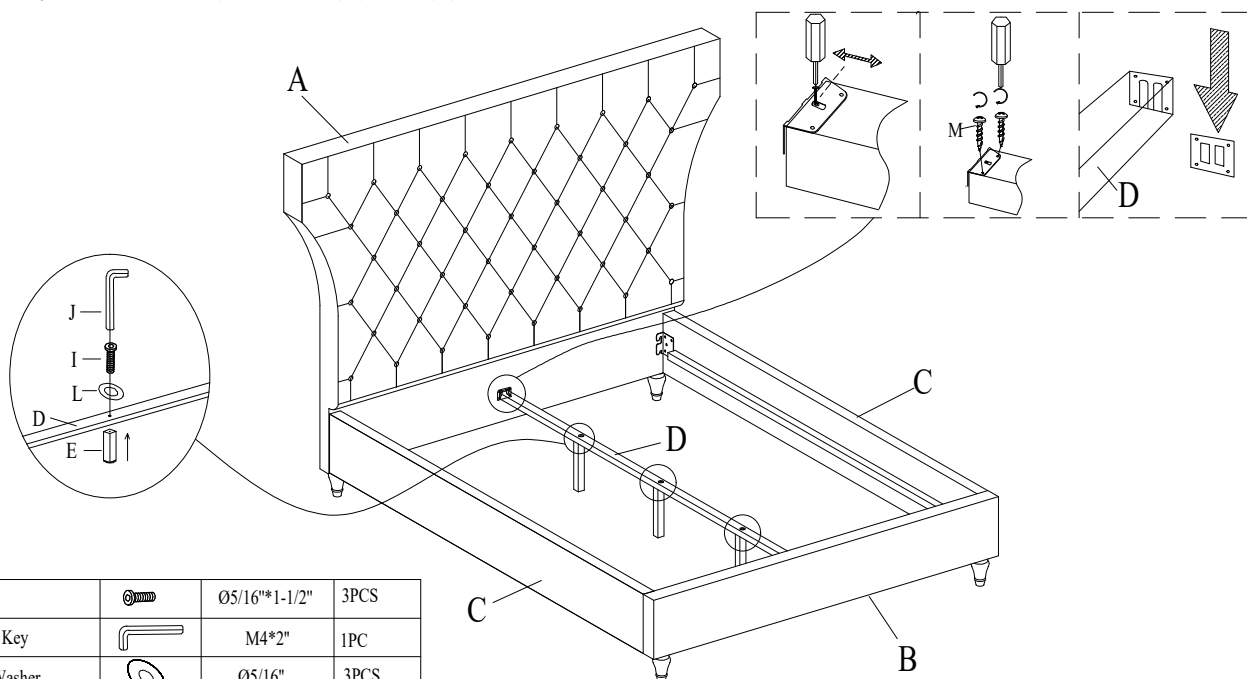

I	Bolt		Ø5/16"*1-1/2"	3PCS
J	Allen Key		M4*2"	1PC
L	Flat Washer		Ø5/16"	3PCS
M	Screw		Ø8*1"	4PCS

ASSEMBLY INSTRUCTIONS

Description: QUEEN BED

Thank you for purchasing this quality product. Be sure to check all packing material carefully for small parts that may have come loose inside the carton during shipment.

Step 4: Assembly slat(G) with side Rail(C).

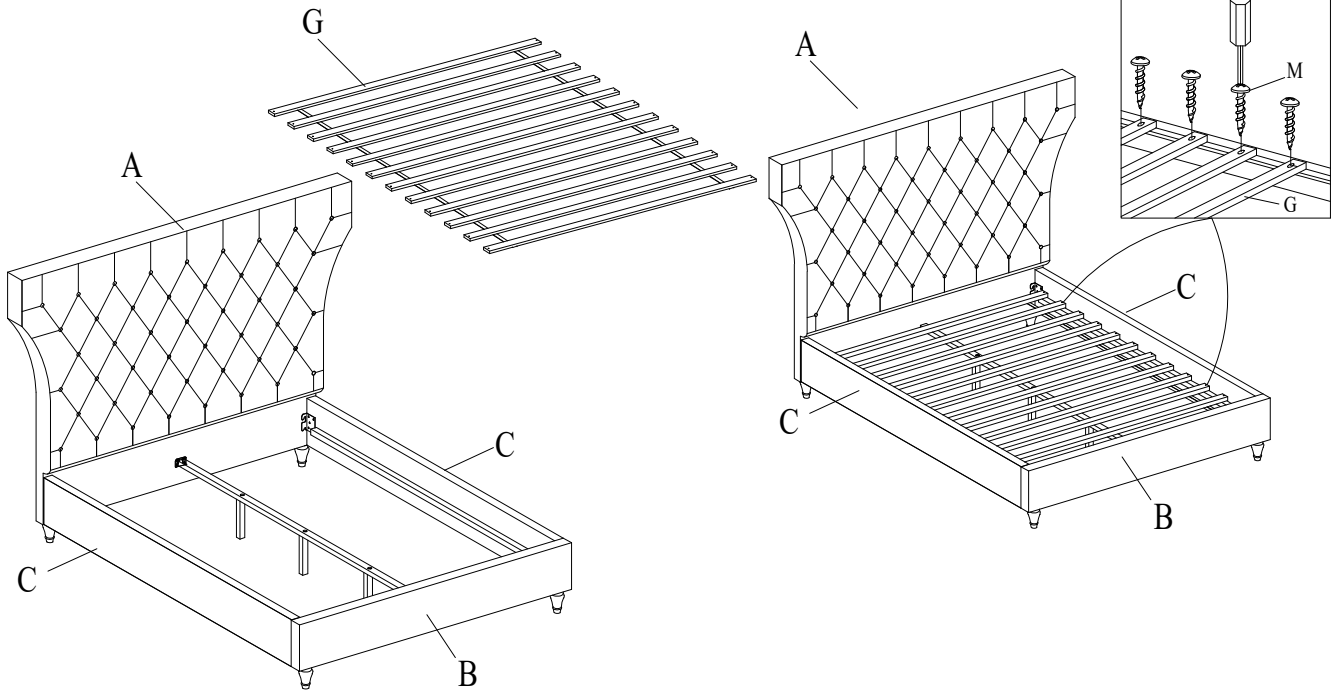

M	Screw		Ø8*1"	24PCS
---	-------	---	-------	-------

Step 6: Completed assembly for a regular bed.

