

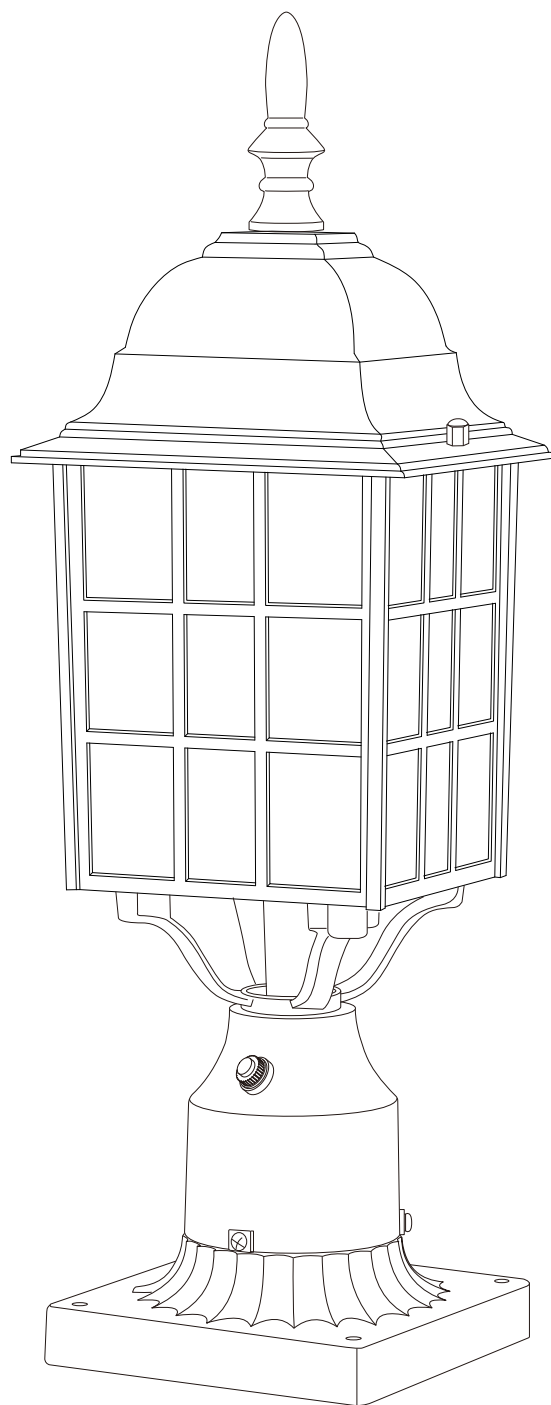



OUTDOOR POST LIGHTS USE AND CARE GUIDE



INSTALLATION INSTRUCTIONS FOR POST LIGHT WITH PHOTOCELL

TYPE				
QTY	3pcs	4pcs	4pcs	2pcs

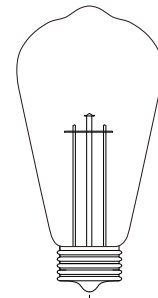
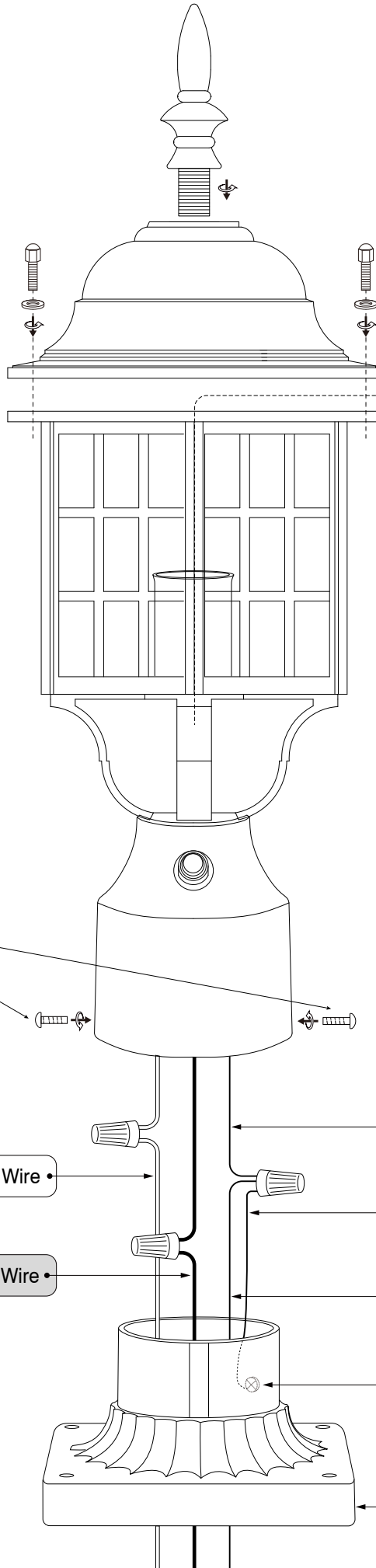

E26 Max. 100W
(Bulbs not included)

In order to adapt to different widths of post, the screw lengthened design.
Do not over-tighten the screws, it will cause the product to break.

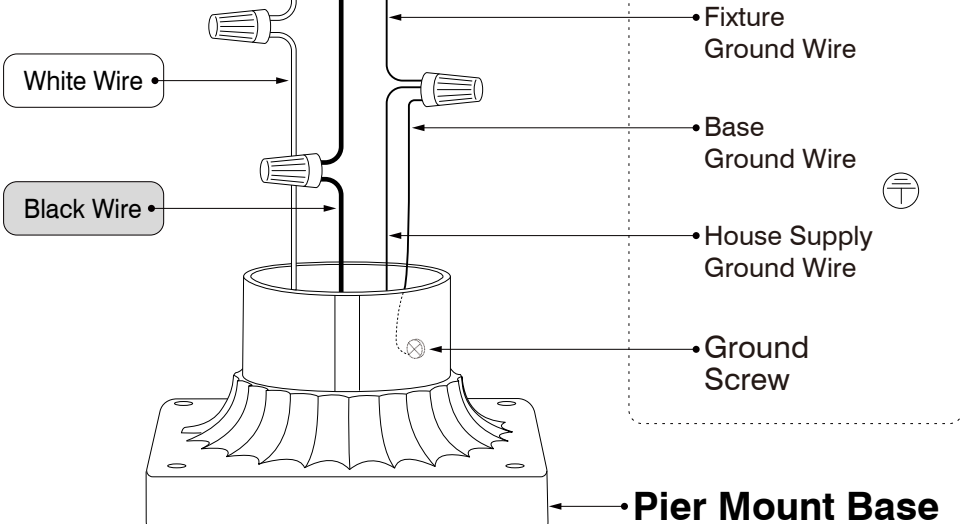
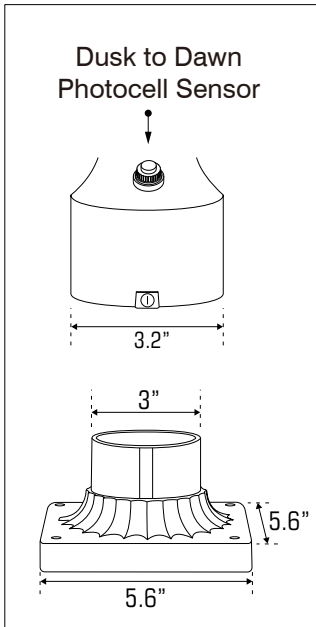

ASSEMBLY INSTRUCTIONS



INSTRUCTIONS PERTAINING TO RISK OF FIRE OR INJURY TO PERSONS
READ ALL INSTRUCTIONS

**IMPORTANT SAFETY
INSTRUCTIONS**
SAVE THESE INSTRUCTIONS

Before starting the installation. Turning the Power Off using the is not sufficient to prevent electrical shock. All electrical connections and installation must be following local codes, ordinances.

TOOLS AND MATERIALS REQUIRED:



Phillips
Screwdriver



Wire Cutters



Pliers



Ladder

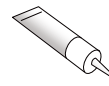

Mastic Silicone
Rubber



Safety Glasses

Before starting the installation. Turning the using is not sufficient to prevent electrical shock. All electrical connections and installation must be following local codes, ordinances.

1. Place the base on top of the post and position as required.
2. Use an electric drill to make 4 holes in the desired surface, place the provided set screws into holes, place the base in line with the holes, and screw mounting screws.
3. Pull the power supply wires out from the post and the fixture wires out from the fixture body to allow the connection of Black, White, and ground lead to appropriate supply leads, using approved wire connectors.
4. Secure the fixture body to the post using the wood screws provided.
5. Install a light bulb. The bulb must not exceed the wattage specified on the fixture label (E26 100W Max.).
6. Use the lock screw screwing the top cover fixture body.
7. Turn on the power.

1 YEAR LIMITED WARRANTY*

This is warranted against defects in material and quality for 1 year from the purchase date.

This warranty does not cover acts of nature such as lightning damage or corrosion and discoloration of components. Nor does it cover damages caused through abuse, improper installation, surges in electric current, or acts of third parties.

This warranty does not cover the costs of removing and resealing the lighting fixture.

If this product falls for any reason covered by this warranty, feel free to contact us.

DUSK TO DAWN SENSOR

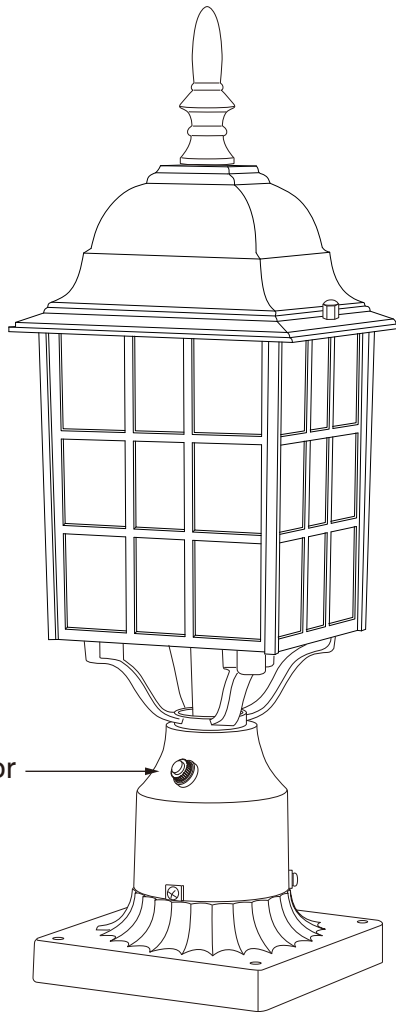
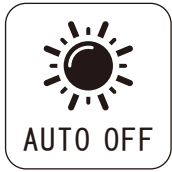

Dusk To Dawn Sensor

PRODUCT DETAILS

Dusk To Dawn Sensor

The sensor can turn on and off the lamp according to the ambient light. When the light is dark, such as at night (5-60 natural light), the lamp will automatically turn on, and when the surrounding environment is bright, such as after dawn, the lamp will automatically turn off.

So you don't have to manually turn on or off the lights, you can keep the switch always on, and automatically turn on and off every day, saving your electricity bills.

If you want to disable this feature, cover the sensor with dark tape.

1 YEAR LIMITED WARRANTY*

This is warranted against defects in material and quality for 1 year from the purchase date. This warranty does not cover acts of nature such as lightning damage or corrosion and discoloration of components. Nor does it cover damages caused through abuse, improper installation, surges in electric current, or acts of third parties.

This warranty does not cover the costs of removing and resealing the lighting fixture.

If this product falls for any reason covered by this warranty, feel free to contact us.