

2 DOOR 3 DRAWER SIDEBOARD ASSEMBLY INSTRUCTIONS

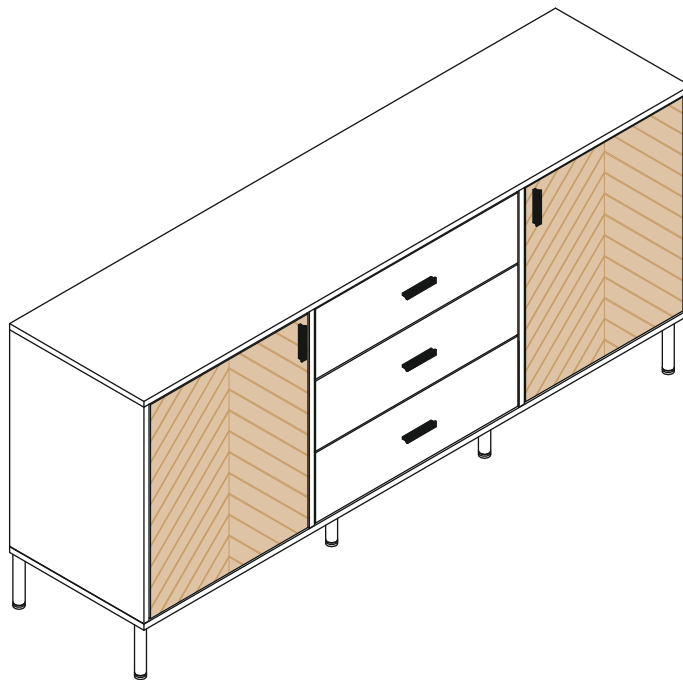

FOR DOMESTIC USE ONLY IMPORTANT PLEASE READ BEFORE YOU CONTINUE FURTHER

THE PRODUCT YOU HAVE PURCHASED WILL GIVE YOU MANY YEARS OF SERVICE IF YOU FOLLOW THE GUIDELINES FOR ITS SAFE ASSEMBLY AND PERIODIC MAINTENANCE AND CLEANING.

ASSEMBLE ON A SOFT CLEAN SURFACE.

DO NOT USE ANY TOOLS OTHER THAN THOSE SHOWN.

ANY SPANNERS OR ALLEN KEYS REQUIRED ARE INCLUDED WITH THE FITTING KIT.

DO NOT FOR ANY REASON USE A POWER TOOL TO ASSEMBLE THIS PRODUCT. ITS USE WILL INVALIDATE ANY CLAIM YOU MAY HAVE AND COULD MAKE THIS PRODUCT UNSAFE.

DEPENDING ON THE AMOUNT OF USE THIS PRODUCT RECEIVES, IT MAY BE NECESSARY TO TIGHTEN UP THE FIXINGS FROM TIME TO TIME. THIS IS COMPLETELY NORMAL FOR ANY FLAT PACK FURNITURE. DO NOT OVERTIGHTEN FIXINGS.

FOR CLEANING, YOU MAY USE A DAMP CLOTH (NOT WET). DO NOT USE POLISH, DETERGENT OR CHEMICAL CLEANERS.



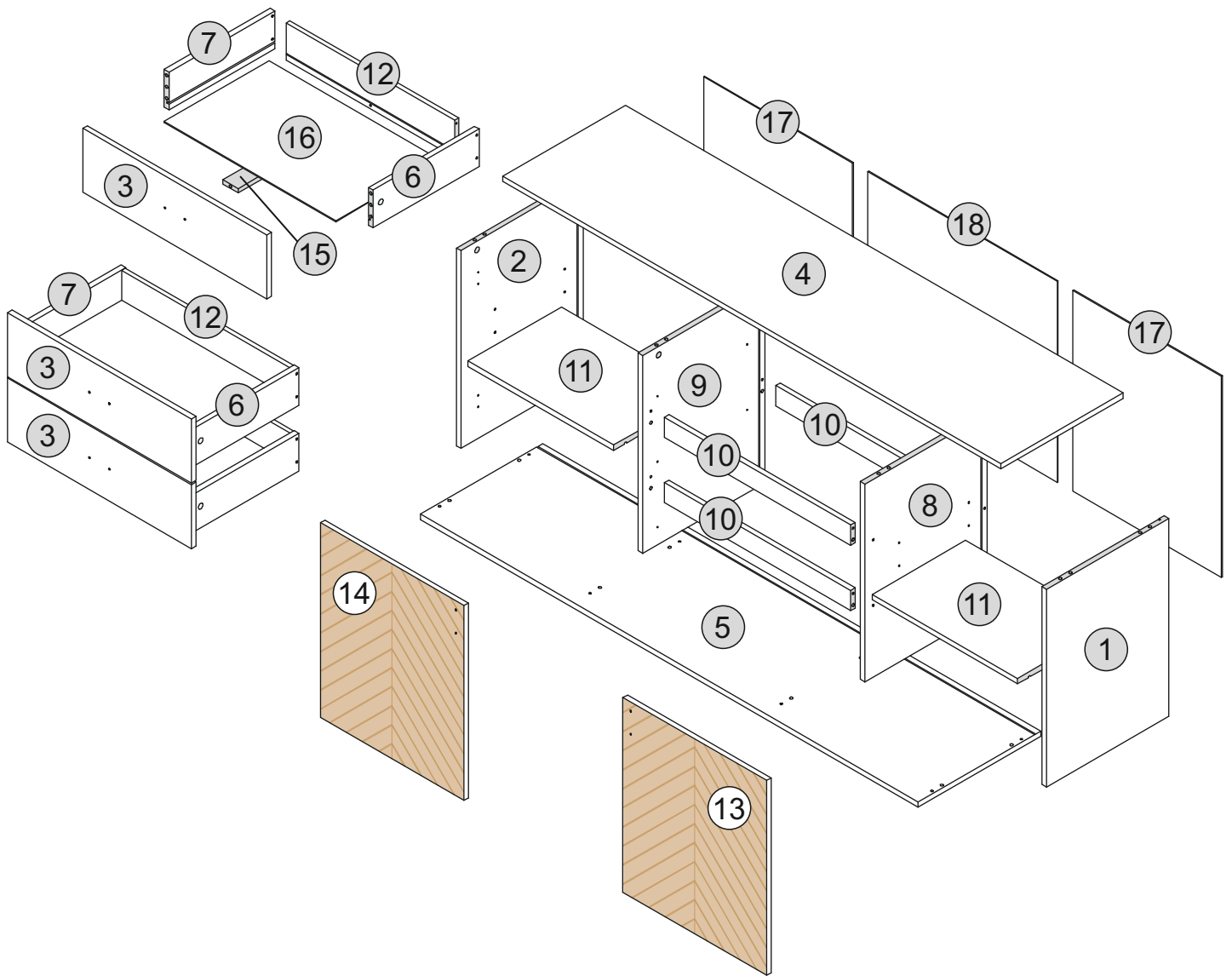













THIS SURFACE OF THIS ITEM IS NOT HEAT RESISTANT. ALWAYS USE A PLACE MAT UNDER HOT OR COLD ITEMS TO PREVENT MARKING.



PART LIST

Part Number	Part Code	Part Description	Quantity	Carton
1	ZF1-01	Right Side Panel	1	1/2
2	ZF1-02	Left Side Panel	1	1/2
3	ZF1-03	Drawer Front	3	1/2
4	ZF1-04	Top Panel	1	1/2
5	ZF1-05	Bottom Panel	1	1/2
6	ZF1-06	Right Drawer Side	3	1/2
7	ZF1-07	Left Drawer Side	3	1/2
8	ZF1-08	Right Centre Panel	1	1/2
9	ZF1-09	Left Centre Panel	1	1/2
10	ZF1-10	Support Panel	3	1/2
11	ZF1-11	Adjustable Shelf Panel	2	2/2
12	ZF1-12	Drawer Back	3	2/2
13	ZF1-13	Right Door	1	2/2
14	ZF1-14	Left Door	1	2/2
15	ZF1-15	Drawer Support	3	1/2
16	ZF1-16	Drawer Base	3	2/2
17	ZF1-17	Small Back Panel	2	2/2
18	ZF1-18	Large Back Panel	1	2/2

HARDWARE LIST

No	Part Name		Qty	Carton
A	M8x30mm Wooden Dowel		x34	1
B	Minifix Cam Bolt <small>(8032t)</small>		x17	1
C	Minifix Cam Nut <small>(1512)</small>		x14	1
D	M3.5x16mm Screw		x64	1
E	M4x45mm Screw		x14	1
F	M4x38mm Screw		x15	1
G	20mm Handle Screw		x10	1
H	Handle <small>(64mm)</small>		x5	1
I	14" Drawer Slide <small>(VKT 0.9 - Black)</small>		x3	1
J	Corner Support <small>(AC101)</small>		x2	1
K	Iron Leg <small>(150mm) - Black</small>		x6	1
L	Shelf Support		x8	1
M	Wall Fixing <small>(4x20mm=1pc)</small>		x1	1
N	M4x20mm Screw		x4	1
O	End Hinges <small>(M11)</small>		x4	1
P	Door Stopper		x2	1
Q	Minifix Cam Nut <small>(1510)</small>		x3	1

TIPS FOR FITTINGS CAM-LOCKS

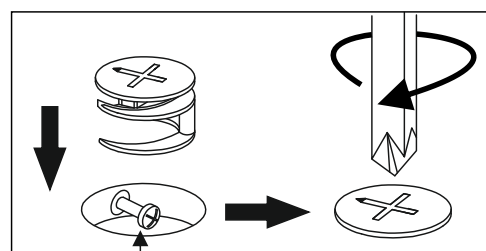
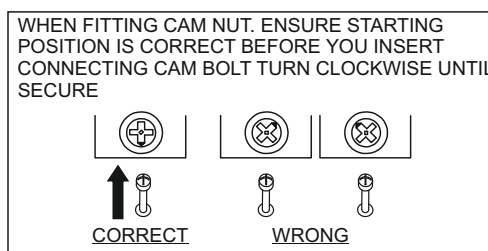

Cam bolt head needs to be in centre

CAMBOLT

Tighten until shoulder in flush with panel. Do not overtighten or undertighten (see example below)

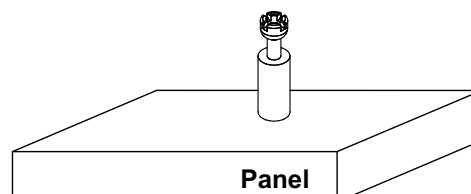
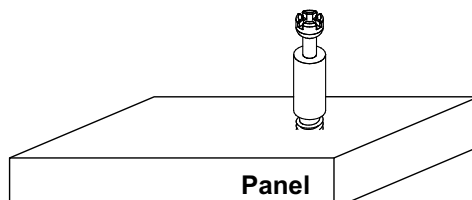
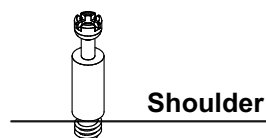

STEP 1

PARTS REQUIRED

1 - RIGHT SIDE PANEL x1

2 - LEFT SIDE PANEL x1

HARDWARE REQUIRED

A  08

C  04

L  04

TOOLS REQUIRED

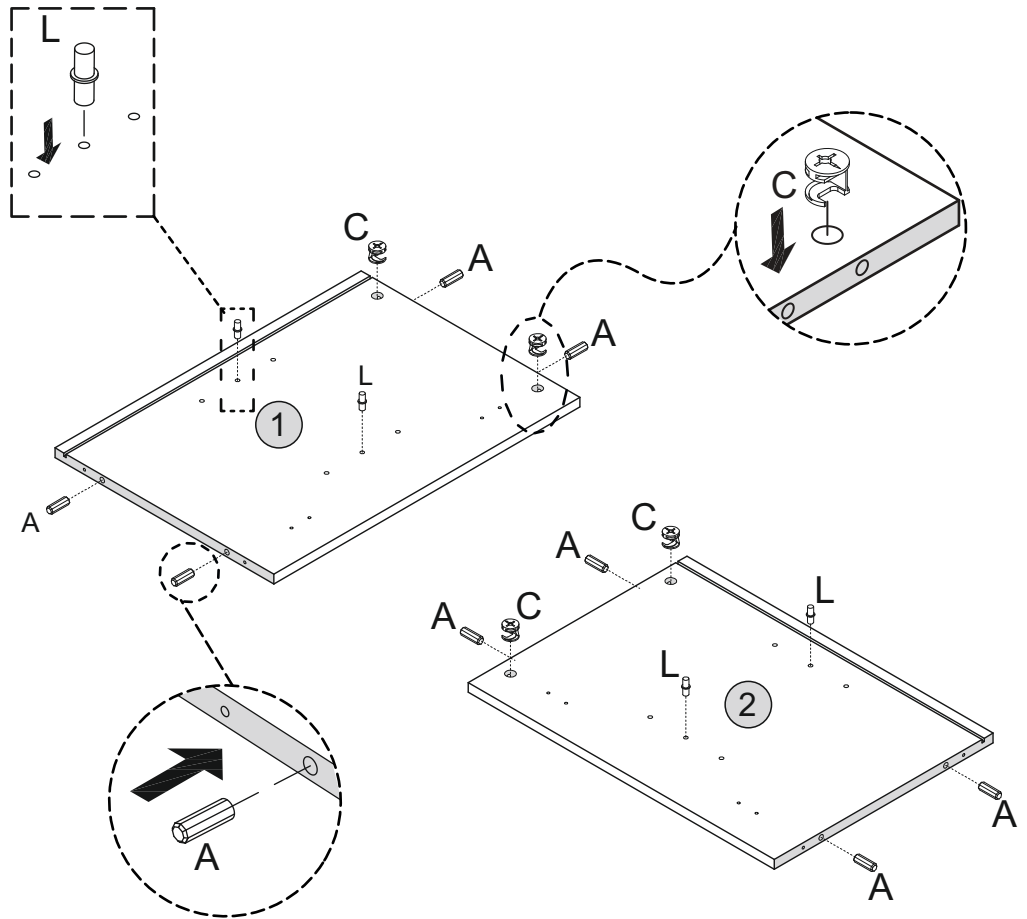
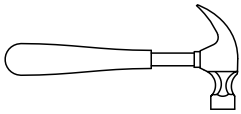

STEP 2

PARTS REQUIRED

8 - RIGHT CENTRE PANEL x1

9 - LEFT CENTRE PANEL x1

10 - SUPPORT PANEL x3

HARDWARE REQUIRED

A  14

L  04

TOOLS REQUIRED

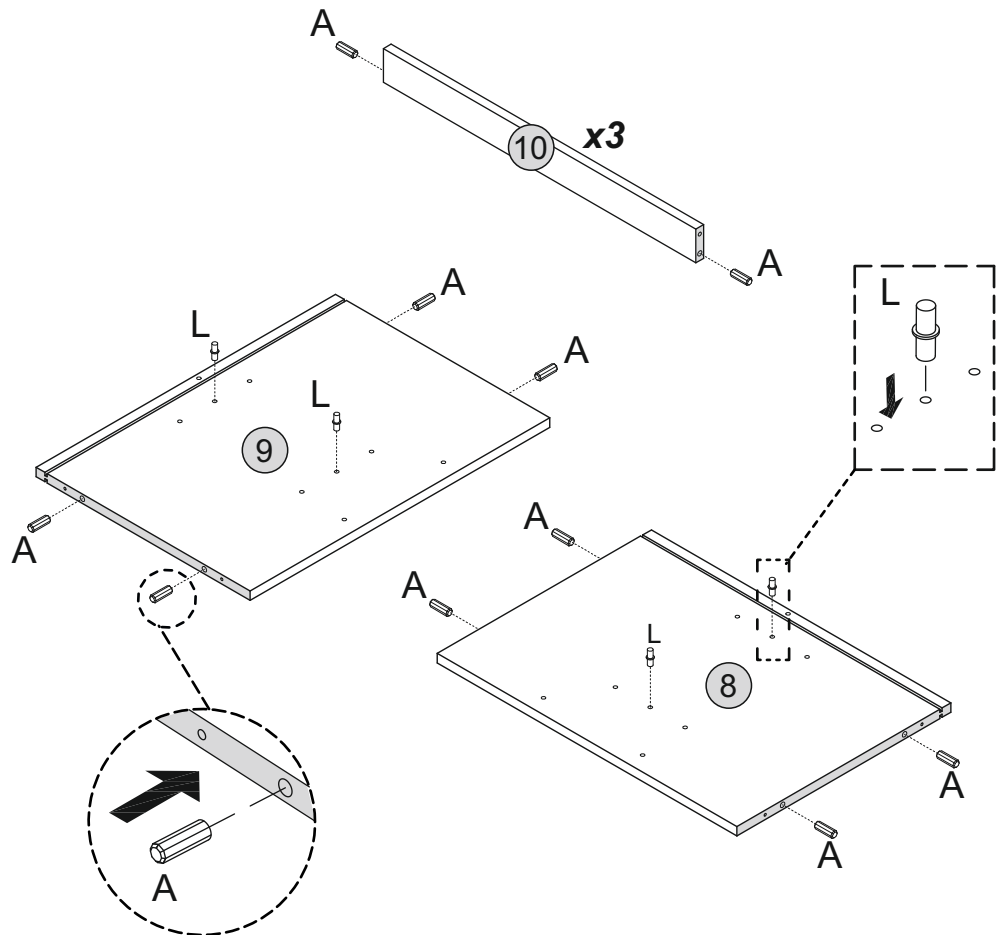
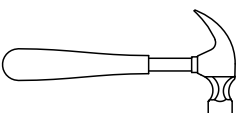

STEP 3

PARTS REQUIRED

4 - TOP PANEL x1

HARDWARE REQUIRED

B  08

P  02

TOOLS REQUIRED

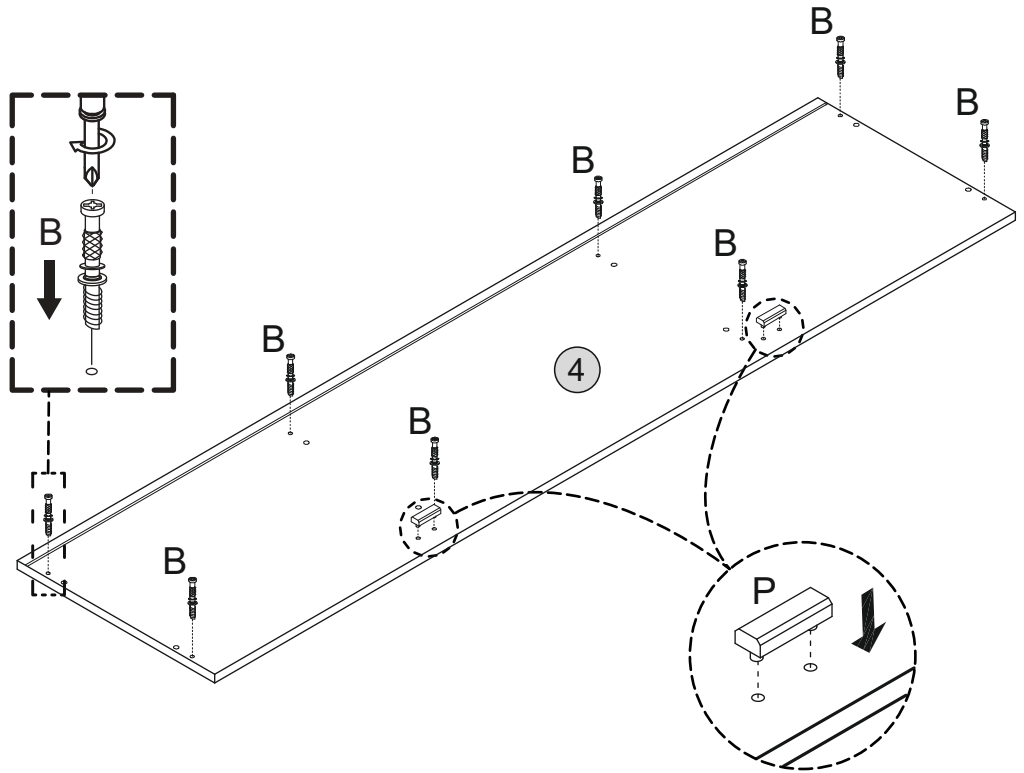
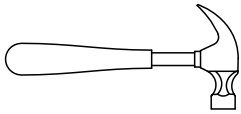
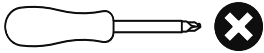

STEP 4

PARTS REQUIRED

8 - RIGHT CENTRE PANEL x1

9 - LEFT CENTRE PANEL x1

HARDWARE REQUIRED

C  04

D  3.5x16mm 12

I  03

TOOLS REQUIRED

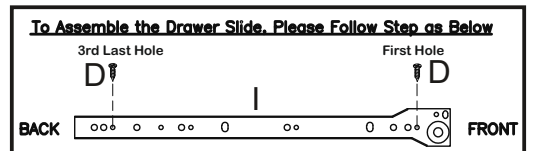
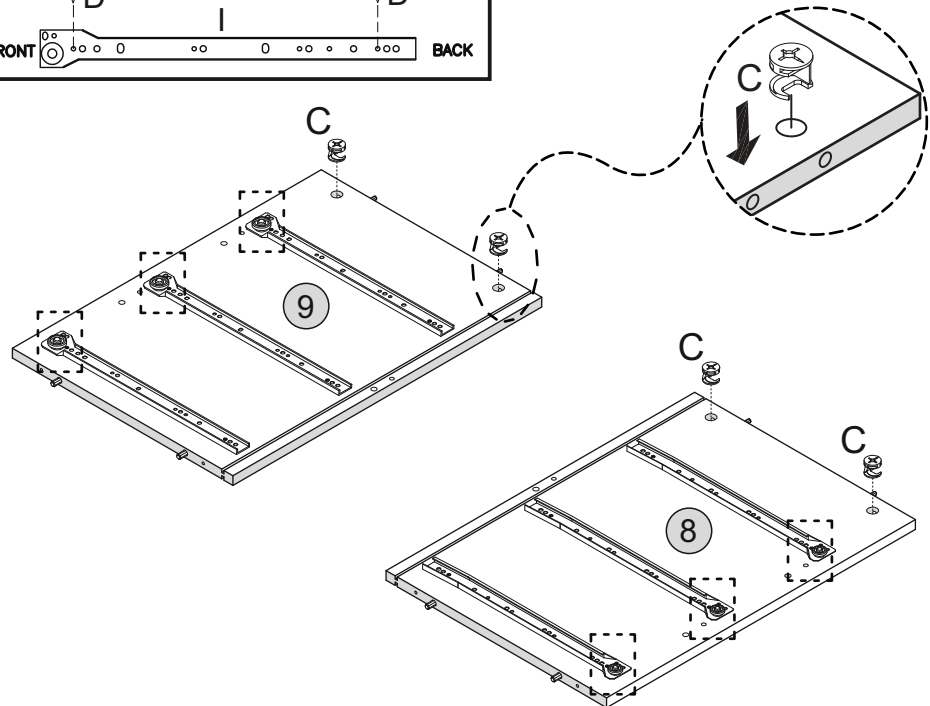
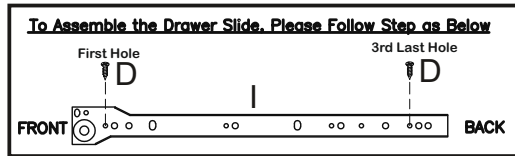
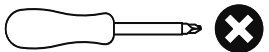

STEP 5

PARTS REQUIRED

13 - RIGHT DOOR x1

14 - LEFT DOOR x1

HARDWARE REQUIRED

D  08
3.5x16mm

O  04

TOOLS REQUIRED

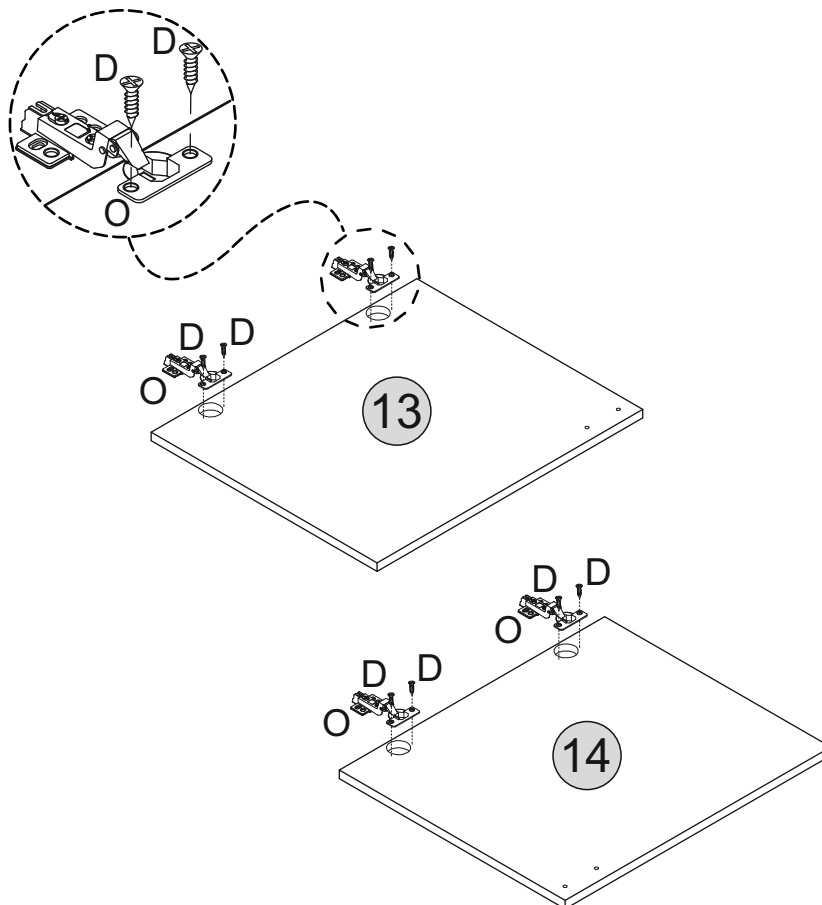
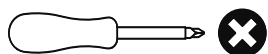

STEP 6

PARTS REQUIRED

8 - RIGHT CENTRE PANEL x1

9 - LEFT CENTRE PANEL x1

10 - SUPPORT PANEL x3

HARDWARE REQUIRED

E  06
4x45mm

TOOLS REQUIRED

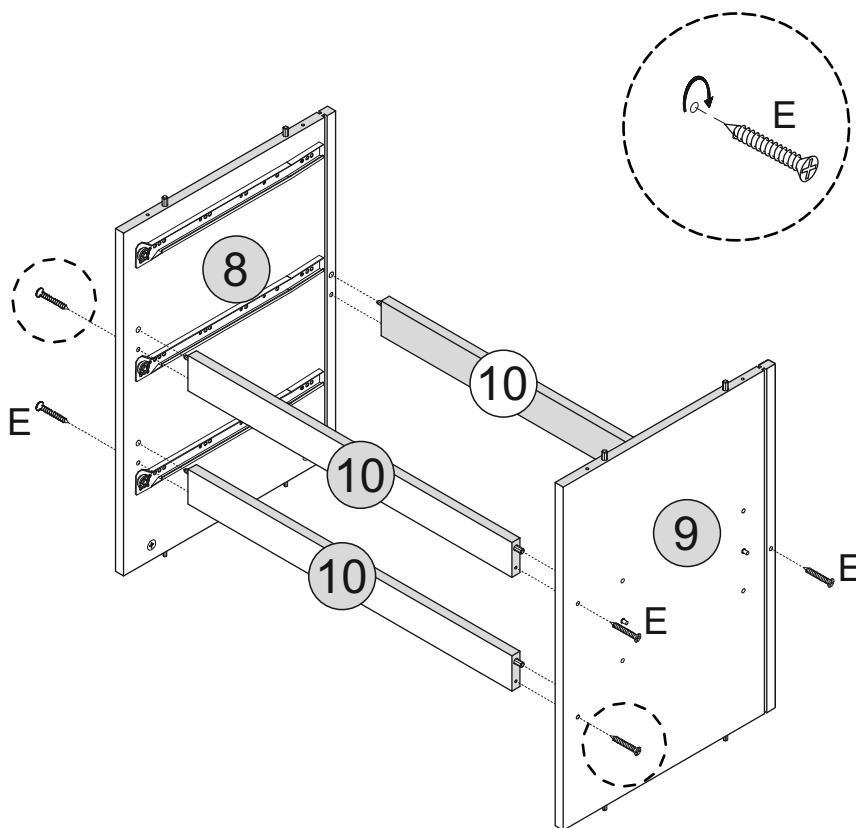
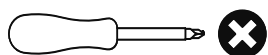

STEP 7

PARTS REQUIRED

- 1 - RIGHT SIDE PANEL x1
- 2 - LEFT SIDE PANEL x1
- 4 - TOP PANEL x1

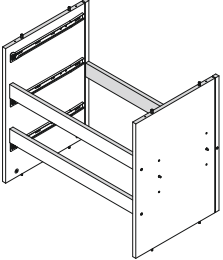

HARDWARE REQUIRED

TOOLS REQUIRED

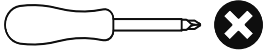

WHEN FITTING CAMS
ENSURE STARTING POSITION IS CORRECT
BEFORE YOU INSERT CONNECTING BOLT
TURN CLOCKWISE UNTIL SECURE

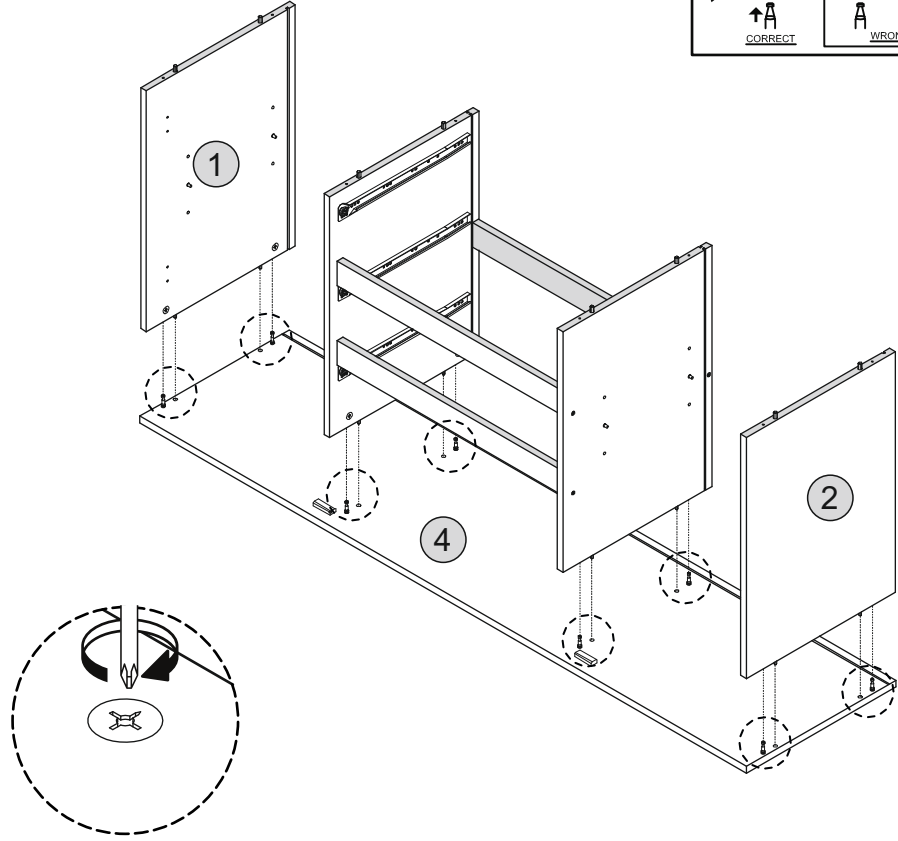
A diagram illustrating the correct and incorrect ways to fit a cam. On the left, a checkmark is next to a cam with a plus sign (+) and an upward arrow (↑), labeled 'CORRECT'. On the right, two 'X' marks are next to cams with a plus sign (+) and a downward arrow (↓), labeled 'WRONG'.

STEP 8

PARTS REQUIRED

- 17 - SMALL BACK PANEL x2
- 18 - LARGE BACK PANEL x1

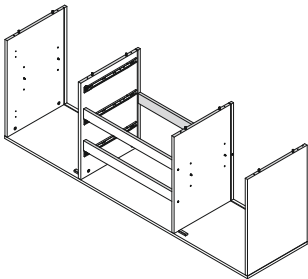

HARDWARE REQUIRED

TOOLS REQUIRED

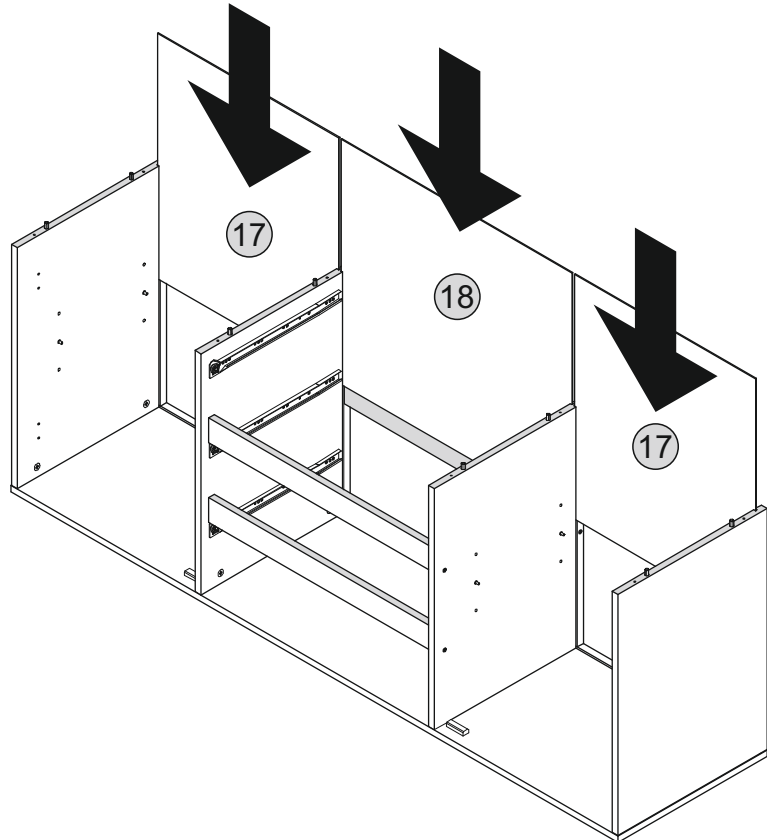

STEP 9

PARTS REQUIRED

5 - BOTTOM PANEL x1

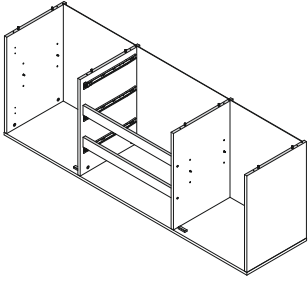

HARDWARE REQUIRED

E  08

TOOLS REQUIRED

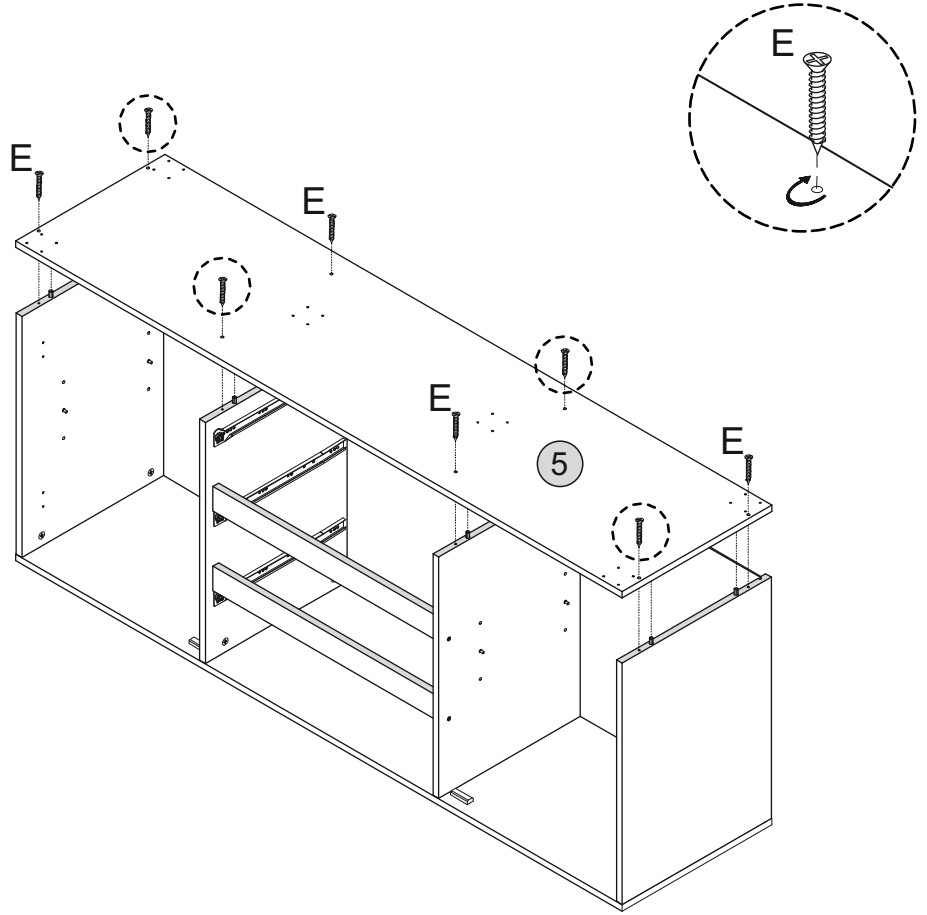
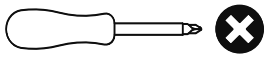

STEP 10

PARTS REQUIRED

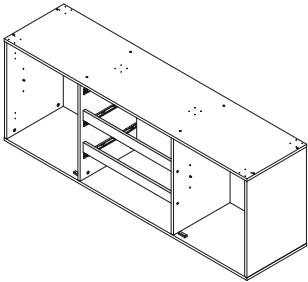

HARDWARE REQUIRED

D  24

K  06

TOOLS REQUIRED

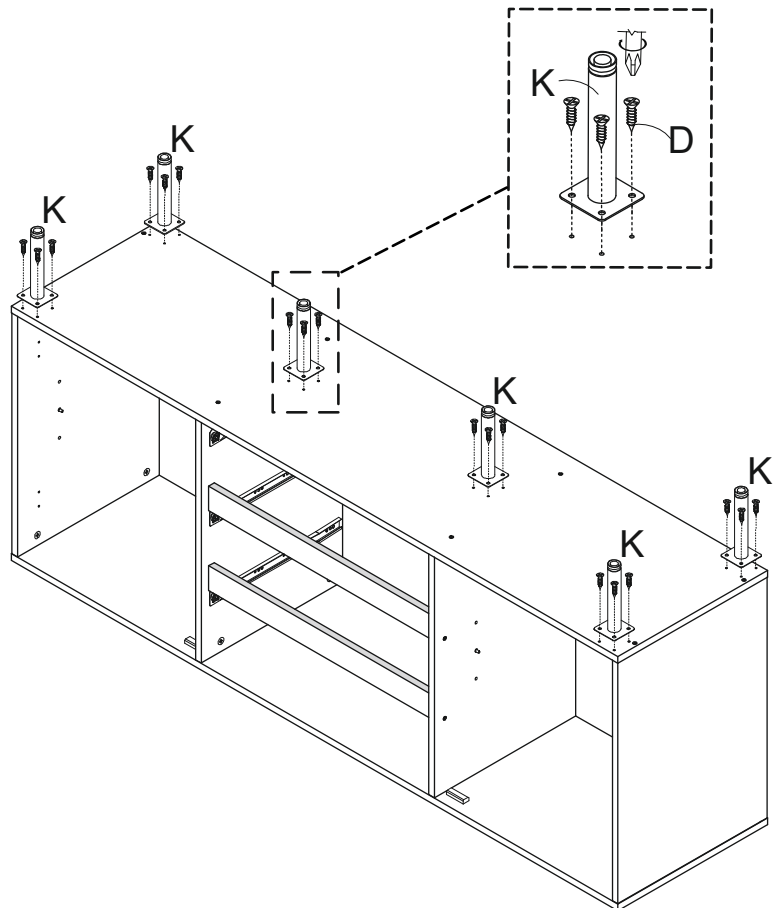
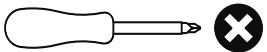

STEP 11

PARTS REQUIRED

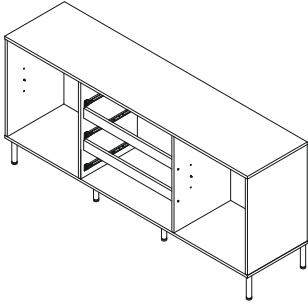

HARDWARE REQUIRED

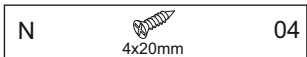
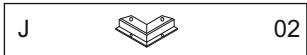

TOOLS REQUIRED

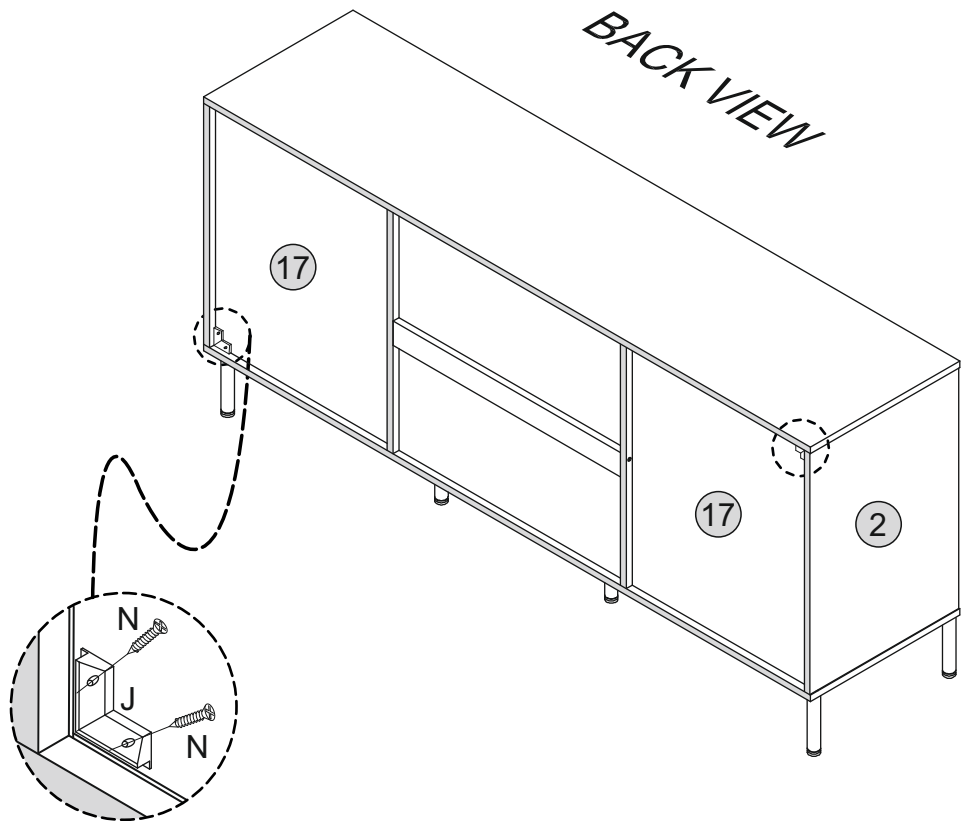
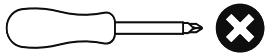

STEP 12

PARTS REQUIRED

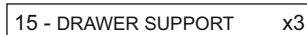

HARDWARE REQUIRED

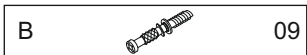
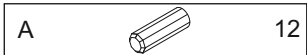

TOOLS REQUIRED

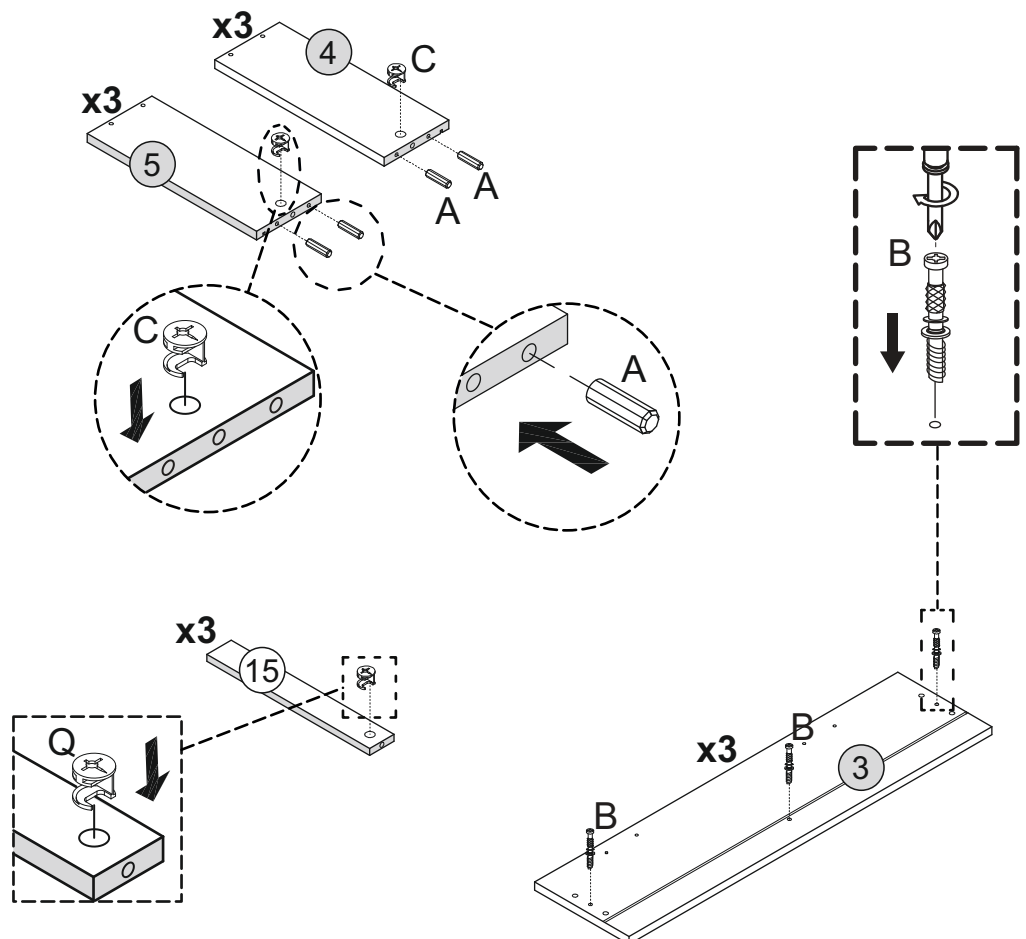
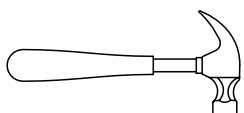
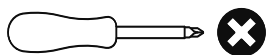

STEP 13

PARTS REQUIRED

4 - RIGHT DRAWER SIDE x3

5 - LEFT DRAWER SIDE x3

12 - DRAWER BACK x3

15 - DRAWER SUPPORT x3

16 - DRAWER BASE x3

HARDWARE REQUIRED

F  15

TOOLS REQUIRED

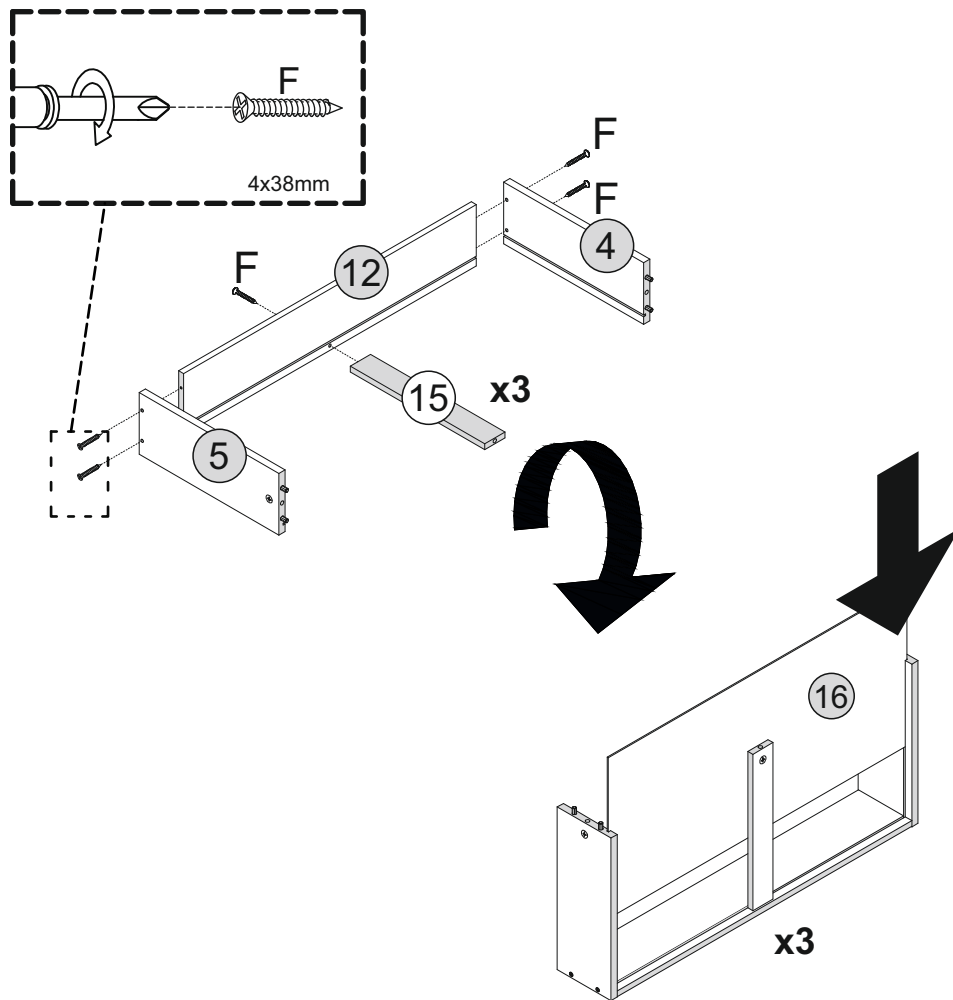
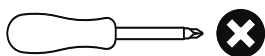

STEP 14

PARTS REQUIRED

3 - DRAWER FRONT x1

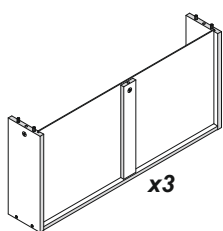

HARDWARE REQUIRED

TOOLS REQUIRED

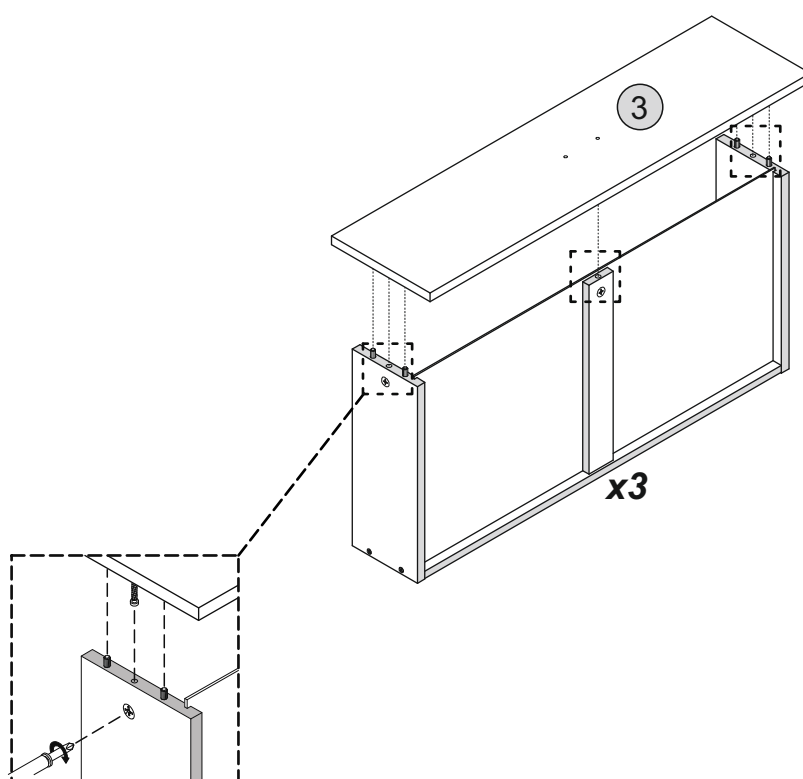
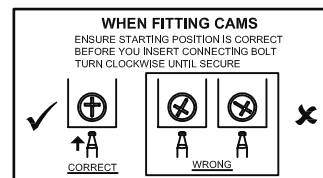
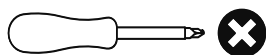

STEP 15

PARTS REQUIRED

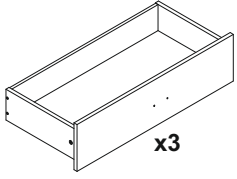

HARDWARE REQUIRED

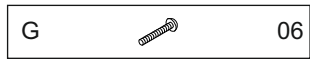

TOOLS REQUIRED

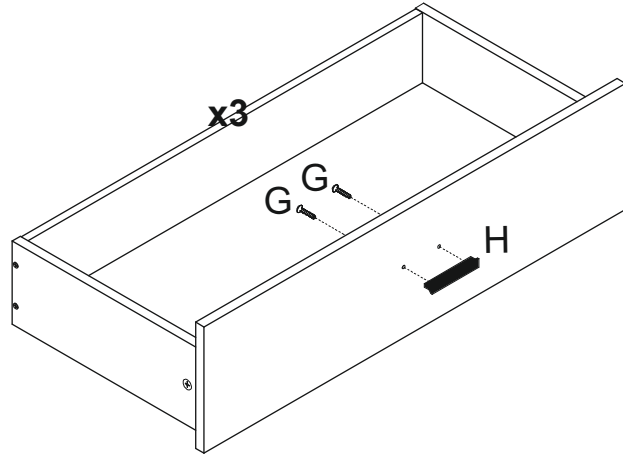
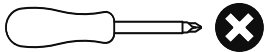

STEP 16

PARTS REQUIRED

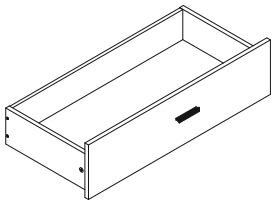

HARDWARE REQUIRED

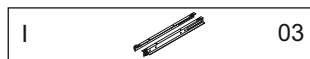
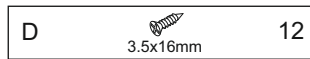

TOOLS REQUIRED

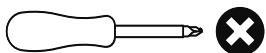

Turn Back 

FRONT

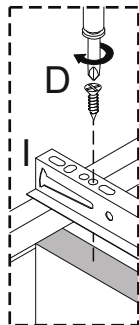

BACK

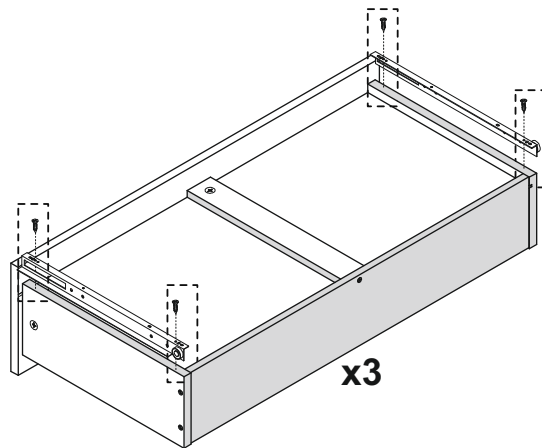
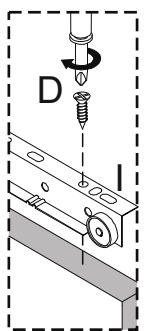

STEP 17

PARTS REQUIRED

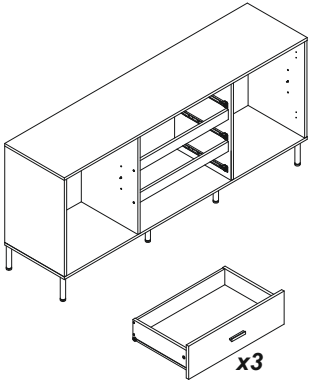

HARDWARE REQUIRED

TOOLS REQUIRED

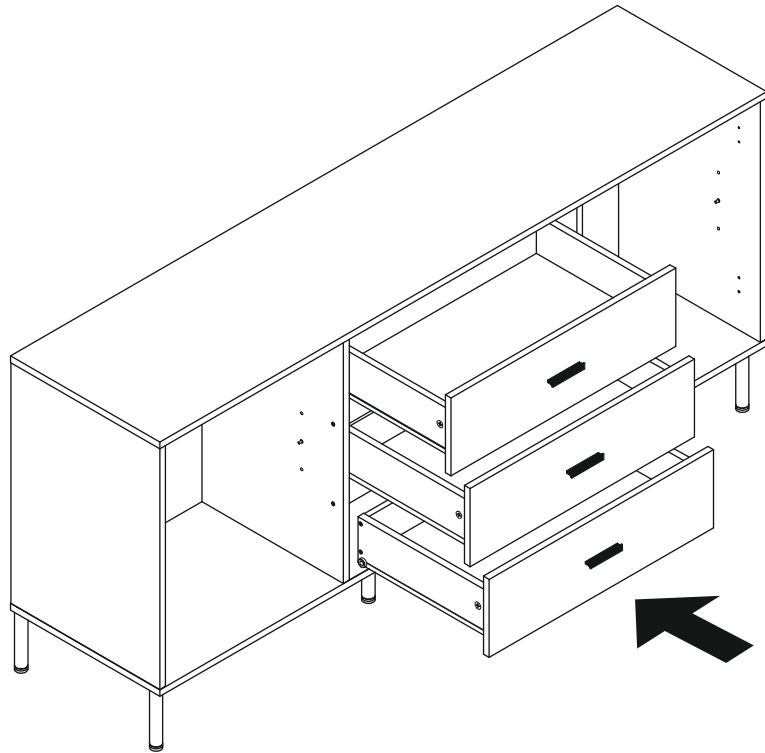

STEP 18

PARTS REQUIRED

11 - ADJUSTABLE SHELF PANEL X2

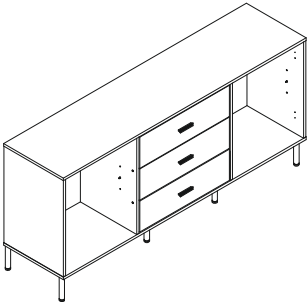

HARDWARE REQUIRED

TOOLS REQUIRED

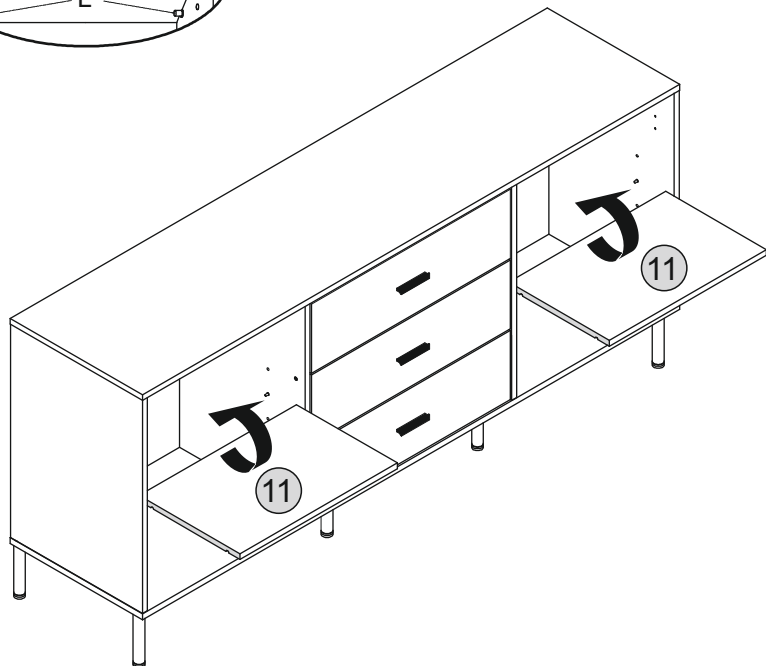
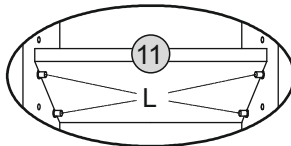

STEP 19

PARTS REQUIRED

13 - RIGHT DOOR x1

14 - LEFT DOOR x1

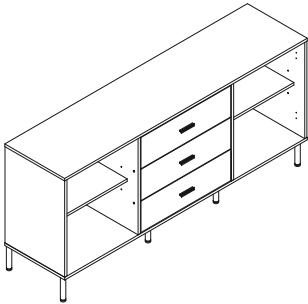

HARDWARE REQUIRED

D  08
3.5x16mm

G  04

H  02

TOOLS REQUIRED

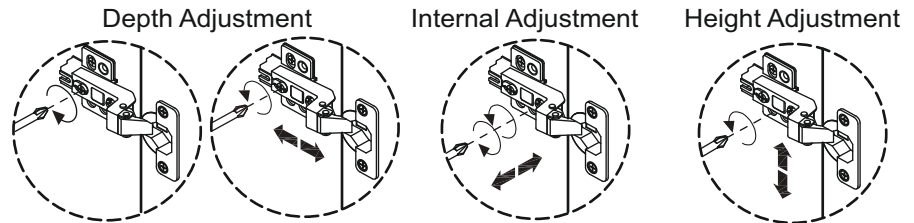
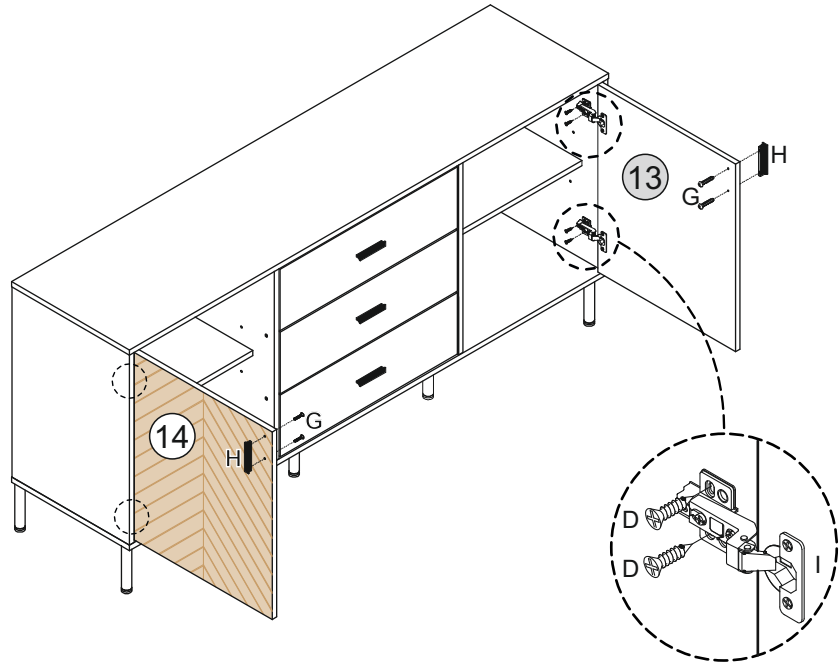
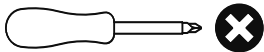

STEP 20

PARTS REQUIRED

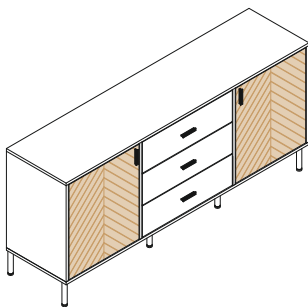

HARDWARE REQUIRED

M  01

TOOLS REQUIRED

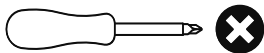

WARNING

Serious or fatal injuries can occur from furniture tipping over. To prevent the furniture from tipping over we recommend that it is permanently fixed to the wall.

Wall fixings are not supplied with this product as different wall materials require different types of fixing devices. Please make sure you use fixings suitable for the walls in your home.

