

After successful installation please put the chair in a shady outside for 1-2 days.

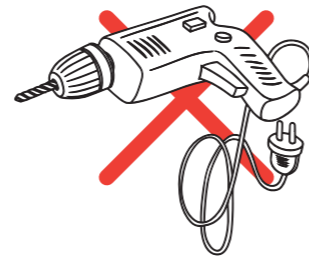

For longer use

Re-tighten bolts every 6 months by using the enclosed allen-key.
*Using an electric drill can damage the chair. Please re-tighten bolts manually.

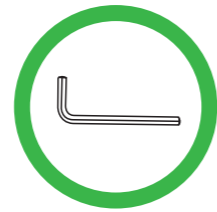

Safety Information



Sit in the center of the chair, with your back to the backrest



Do not sit at the front edge of the chair



Do not stand on the chair



Do not use the chair with more than one person



Do not push the chair around when a person is sitting in it



Do not push down on the backrest when a person is reclined



Do not place all your weight on only the backrest

INSTRUCTION MANUAL



INSTRUCTION MANUAL

Package List



(1)*1 Seat



(2)*1 Back



(3)*1 Gas Lift

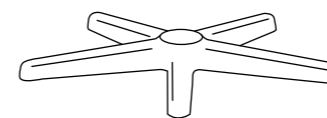

(4)*1 Base

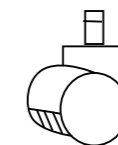

(5)*5 Casters



(6)*2 Bolts



(7)*1 Wrench

Assembly Instruction

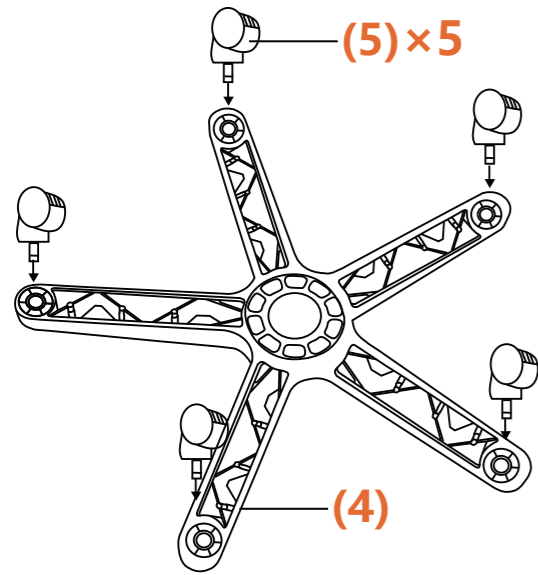

1 Press the Casters (5)*5 into the holes at the end of each Leg of Base (4).

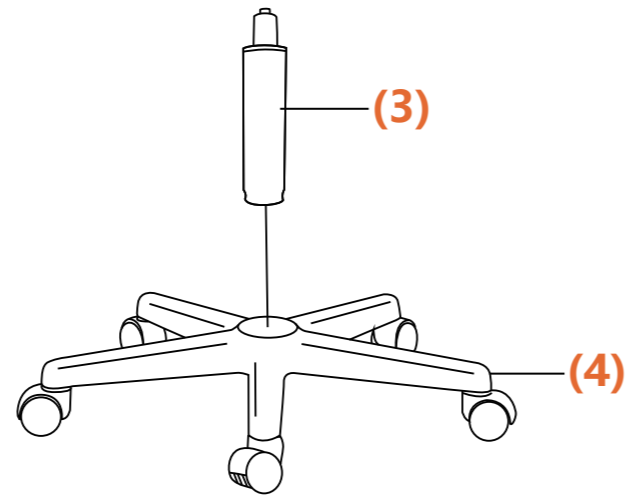

2 Insert the Gas Lift (3) into the center of the Base.

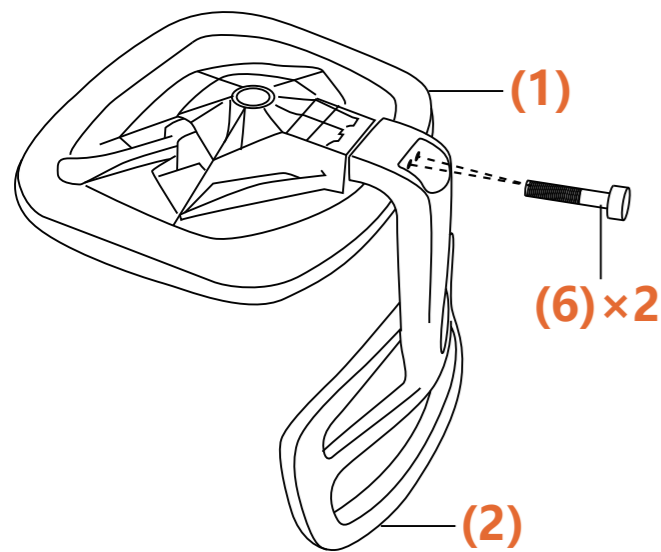

3 Align Back with Seat, install Back (2) to the Seat (1) with Bolts (6)*2.

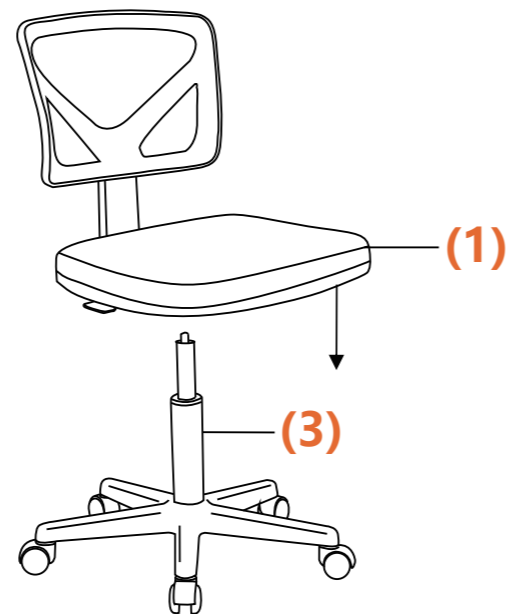

4 Align the center hole of the Seat (1) with Gas Lift (3) and press the Seat down until it is fully secured.

Seat Height: Paddle-shaped lever on the right side

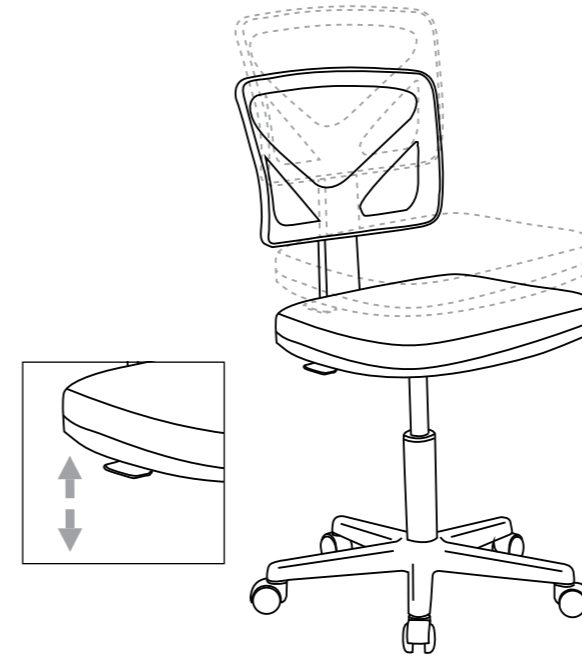

↑ To raise:
While taking your weight off chair,
lift lever up.

↓ To lower:
While seated, lift lever up.

CAUTION:

- * Before using the chair, check to ensure that all bolts are fully tightened.
- * Lubricate all parts and tighten all bolts every 6 months or whenever needed.