





# ASSEMBLY INSTRUCTION

Read this instruction carefully. Remove all wrapping material, staples and straps from the carton.  
See hardware and furniture part list  
For guidance. Be sure you have all wooden furniture parts on a clean and flat soft surface, such as a carpet or rug, to prevent from being scratched. Follow the figure to start assembling.

## CAUTION :

1. Do not FULLY - TIGHTEN the nut or screw until all is ready to assemble.
2. Do not OVER - TIGHTEN the nut or screw to avoid causing damages to the thread.
3. Keep all hardware part out reach of children.

NO	PART LIST	QTY
A	BACK REST	1 PC
B	FRONT LEG	1 PC
C	SIDE RAIL	2 PCS
D	CUSHION SEAT	1 PC

NO	DESCRIPTION	QTY
1	JCBC SCREW M6 X 50MM 	6 PCS
2	WOOD DOWEL Ø8 x 30MM 	4 PCS
3	CSK SCREW M4 x 30MM 	3 PCS
4	SPRNG WASHER M6 	6 PCS
5	M4 ALLEN KEY 	1 PC

## STEP 1

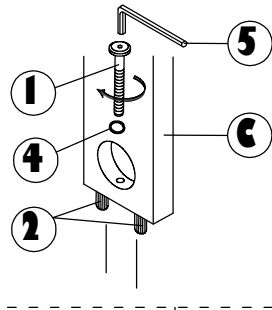

## STEP 2

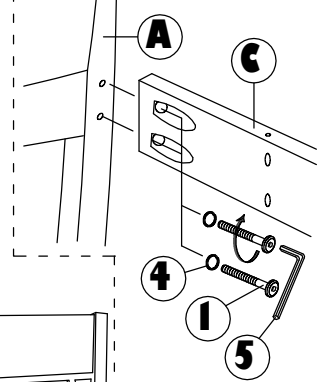

## STEP 3

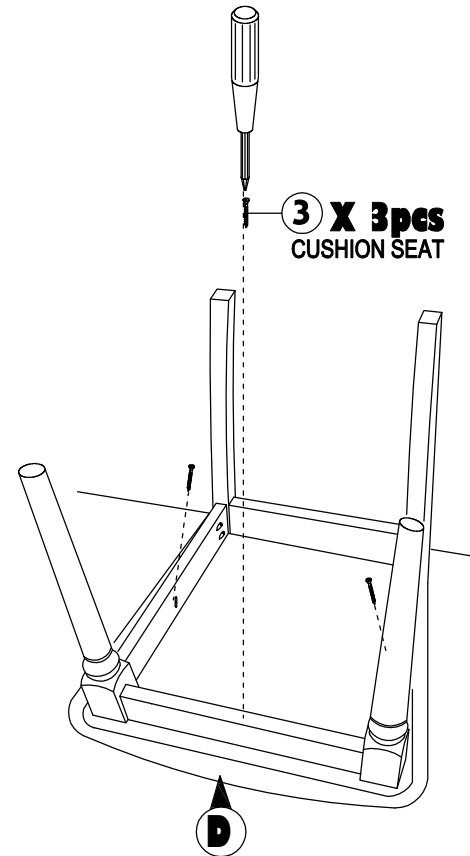

## STEP 4

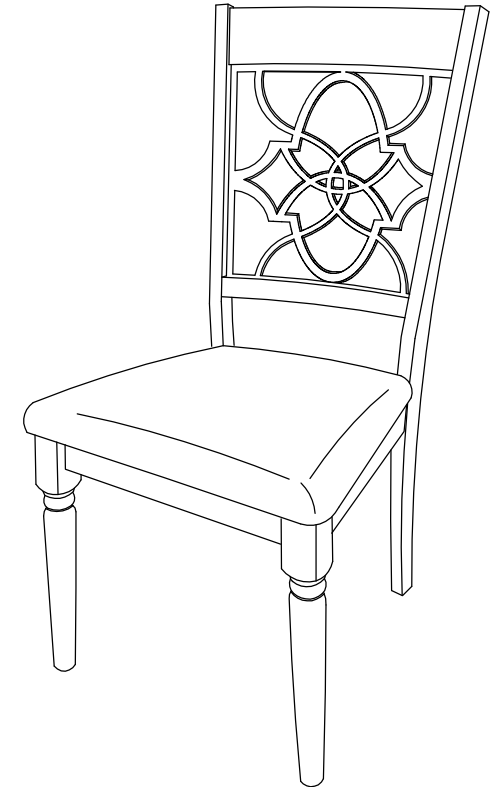

COMPELETE ASSEMBLE

# ASSEMBLY INSTRUCTION







MODEL : 7048T

Read this instruction carefully. Remove all wrapping material, staples and straps from the carton. See hardware and furniture part list For guidance. Be sure you have all wooden furniture parts on a clean and flat soft surface, such as a carpet or rug, to prevent from being scratched. Follow the figure to start assembling.

**CAUTION :**

1. Do not FULLY - TIGHTEN the nut or screw until all is ready to assemble.
2. Do not OVER - TIGHTEN the nut or screw to avoid causing damages to the thread.
3. Keep all hardware part out reach of children.

NO	PART LIST	QTY
A	TABLE TOP	1 PC
B	TABLE LEG RIGHT / LEFT	2 SET
C	TABLE SUPPORT	1 SET
D	BOTTOM SUPPORT	1 SET

NO	DESCRIPTION	QTY
1	JCBC SCREW M6 x 90MM 	4 PCS
2	JCBC SCREW M6 x 50MM 	1 PC
3	JCBC SCREW M6 x 25MM 	8 PCS
4	CSK SCREW M4 x 30MM 	12 PCS
5	SPRING WASHER 	13 PCS
6	ADJUSTER 	4 PCS
7	M4 ALLEN KEY 	1 PC

**STEP 1**

Firstly, connect C to B according to the hole using hardware number 1, 5 and 7.

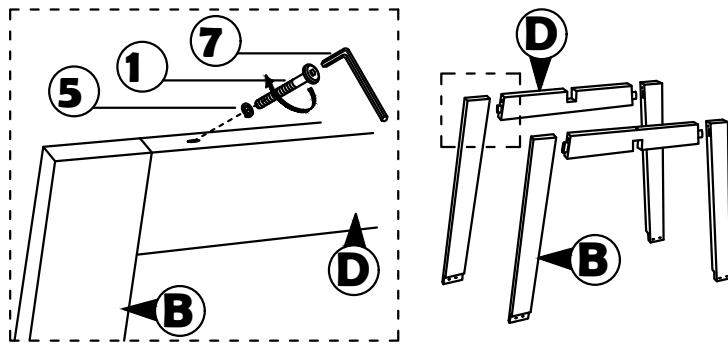

**STEP 2**

Then, align both part of D to form of 'X' and tighten it using hardware number 2, 5 and 7. Adjust 6 on B to stabilize the table leg.

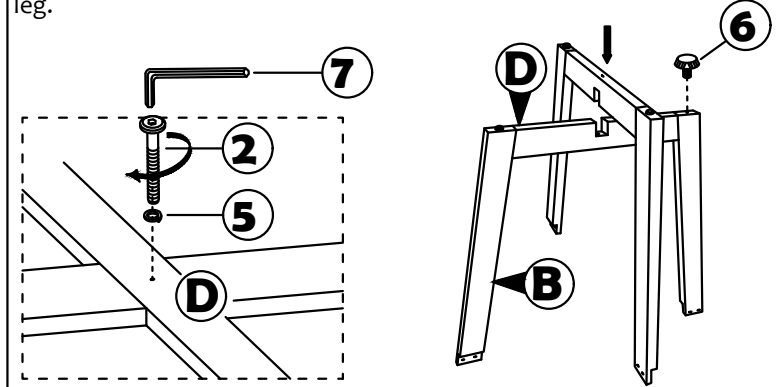

**STEP 3**

Align both part C to form of 'X'.

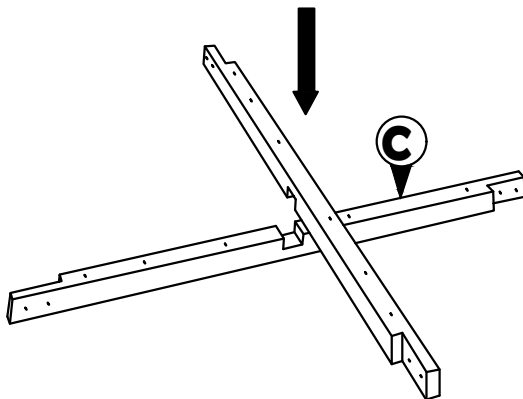

**STEP 4**

Fasten all the part in STEP 2 to C according to the hole using hardware number 2, 3, and 4.

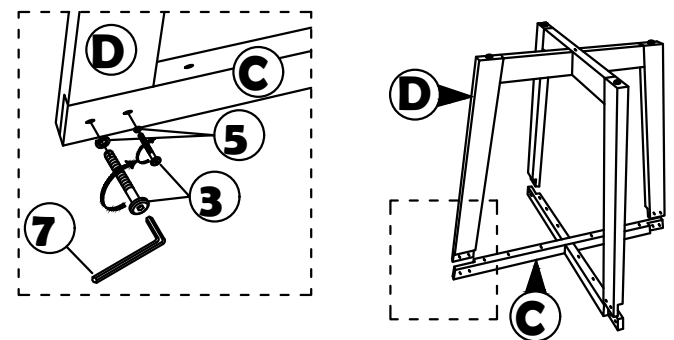

**STEP 5**

Align part C to A; make it center and tighten it using hardware number 3.

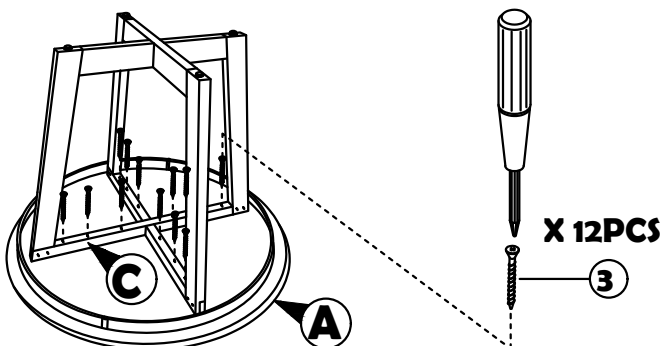

**STEP 6**

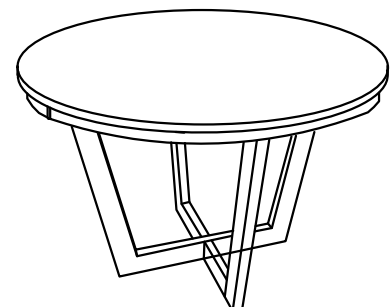

COMPLETE ASSEMBLE