

Thank you for purchasing this quality product. Be sure to check all packing material carefully for small parts, which may have come loose inside the carton during shipment. Identify and count all parts and compare with the hardware list below.









Caution: Please read Instructions thoroughly before unpacking assembly.

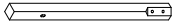

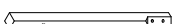

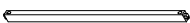

1. We recommend that you should assemble this product with the assistance of another person; this will make assembly easier, and will help to eliminate damage the product or injury to persons during assembly.

2. Please do not over tighten screws or bolts until the assembly is complete.

3. Please put all parts on a non-abrasive floor before assembly, and follow the assembly steps to assemble.

Your newly purchased product correctly and efficiently.

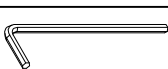
PARTS LIST			
NO	SKETCH	COMPONENT	Q'TY
A		Table Top	1pc
B		Left Front Leg	1pc
C		Right Front Leg	1pc
D		Left Back Leg	1pc
E		Right Back Leg	1pc
F		Side Stretcher	2pcs
G		Back Stretcher	1pc
H		Stool Top	1pc
I		Stool Leg	4pcs
J		Mirror	1pc
K		Supports Bar	2pcs

HARDWARE LIST			
NO	SKETCH	COMPONENT	Q'TY
1		Bolt Ø1/4" *70mm	8pcs
2		Spring Washer Ø1/4" *11*2mm	24pcs
3		Flat Washer Ø1/4" *19*2mm	24pcs
4		Screw Ø4/32mm	6pcs
5		Allen Key M4	1pc
6		Bolt Ø1/4" *45mm	8pcs
7		Bolt Ø1/4" *38mm	8pcs

CARTON : HARDWARE / PART LIST LOCATION :

- Part A (Table Top) > Put at inner carton top .
- Part B,C,D,E, & I (Table legs / Stool legs) > pack in inner box put it underneath table top.
- Part F & G (front and side stretcher) > put in inner box side and front of table.
- Part H (Stool top) > put beside the mirror inner box.
- Part J & K (Mirror and support bar) > pack in inner box put underneath leg inner box.
- Step 2 & 3 & 5 & 7 Pack in blister hardware put at bottom of carton box .

Step 1

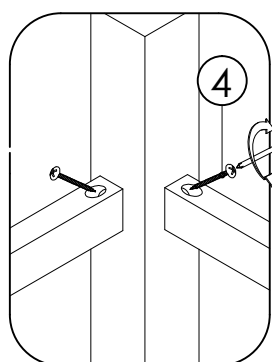
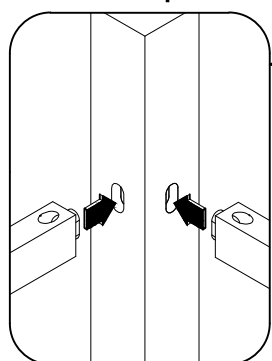

Step 2

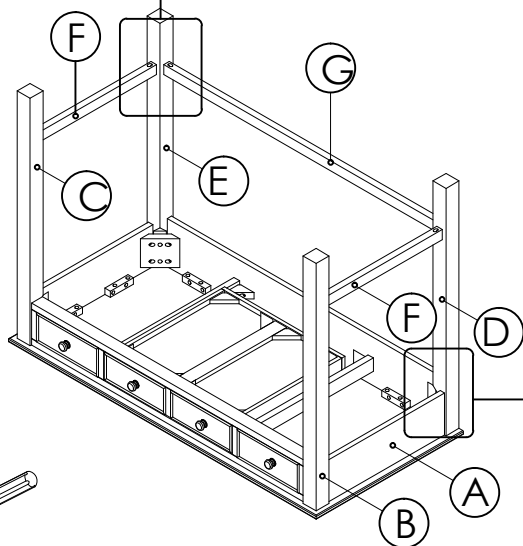

Step 3

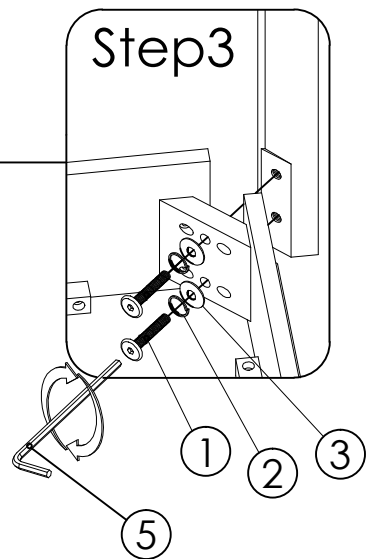

Step 4

Rotate

