

# Assembly Instructions

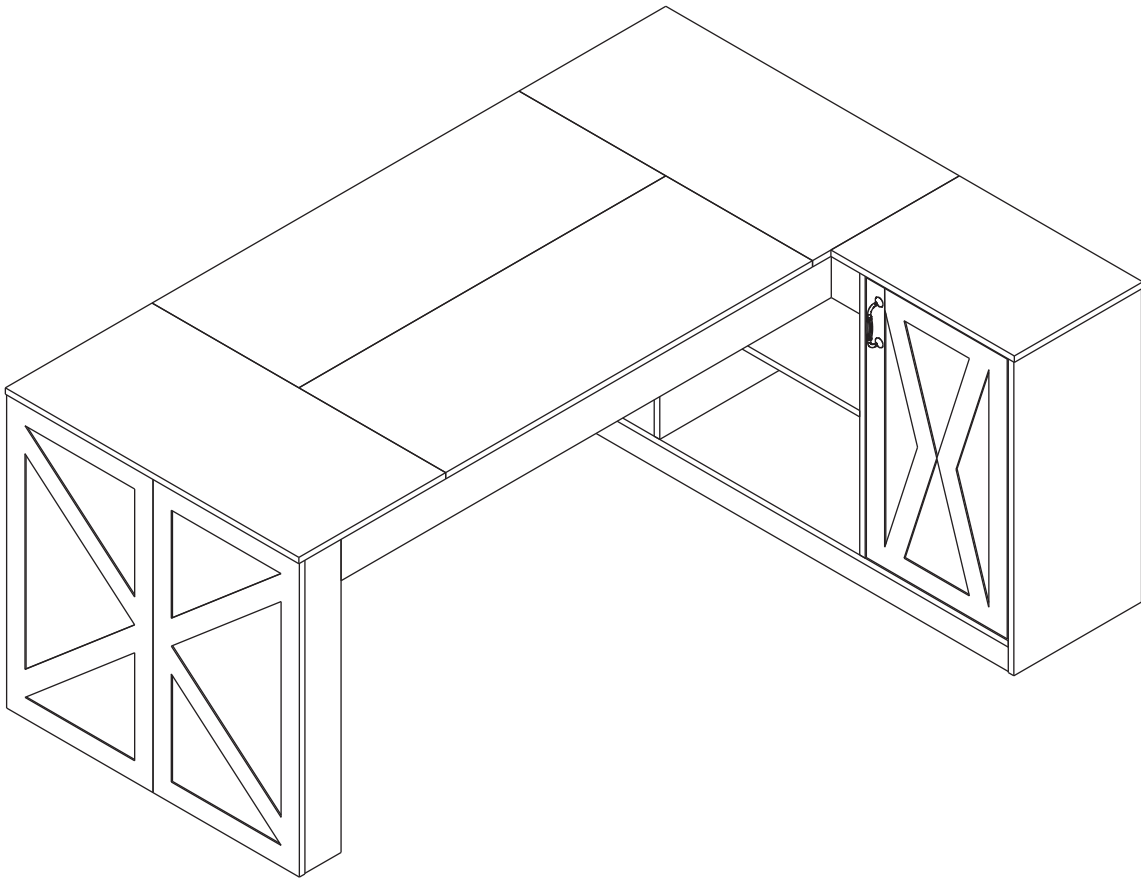

Office Table		
--------------	--	--

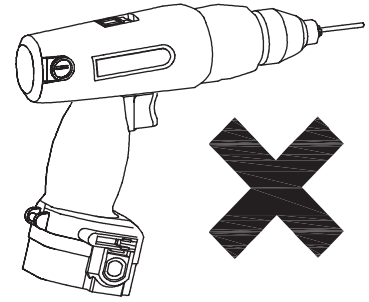
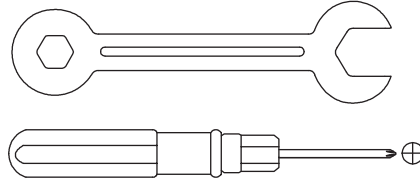
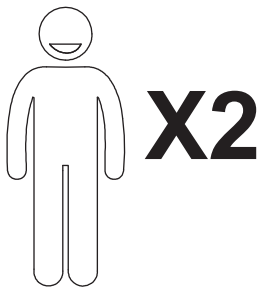

We recommend using hand tools for assembly.

If an electric screwdriver is used, reduce power and torque to avoid damage to the product.

---

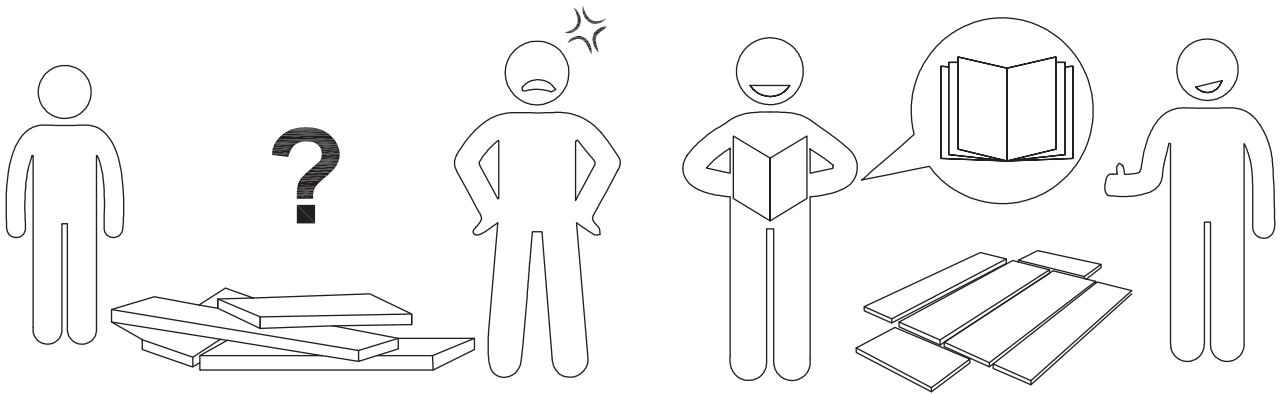

---

## AVOID SCRATCHES

In order to avoid scratching, this furniture should be assembled on a soft surface, such as a rug.

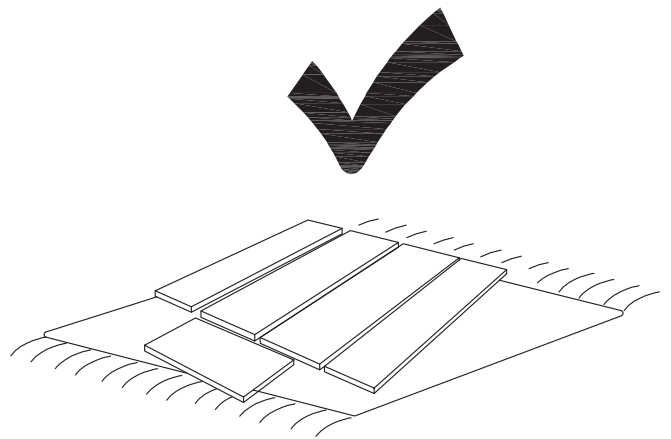
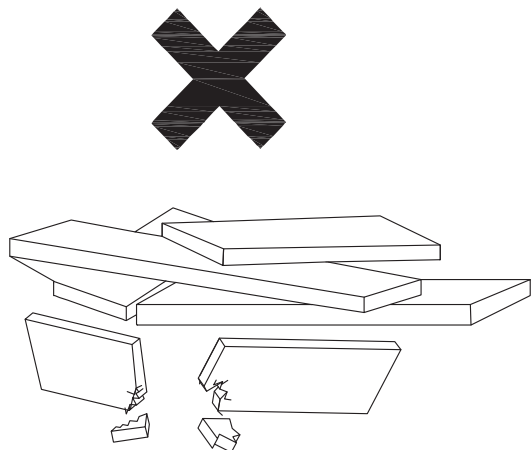

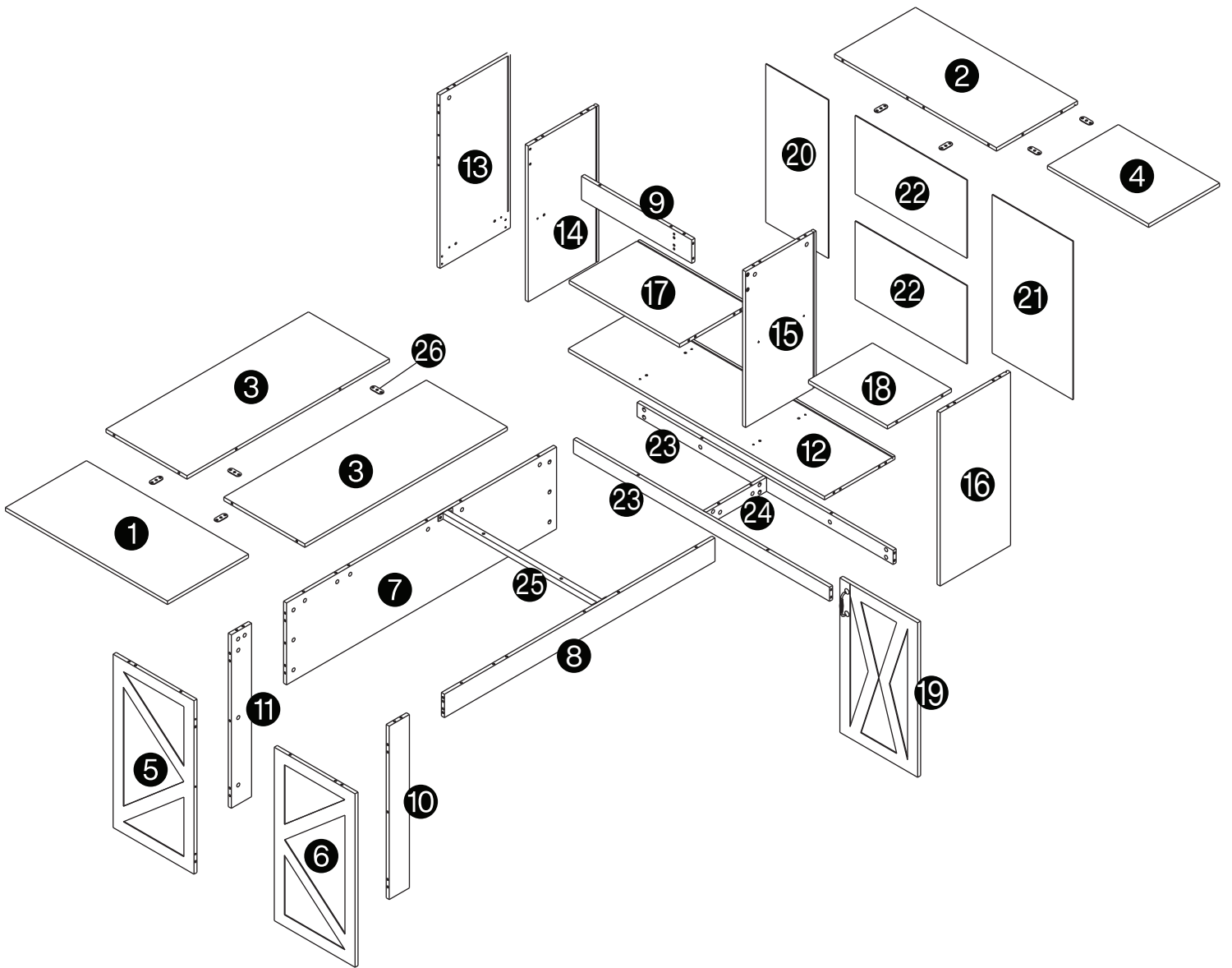







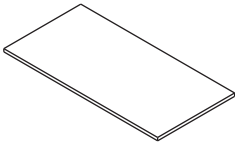
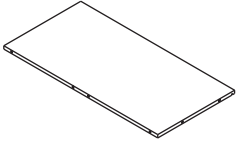
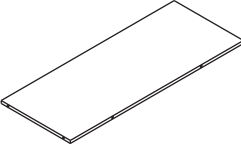
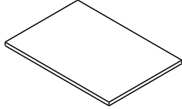
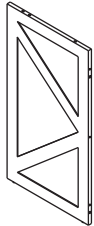
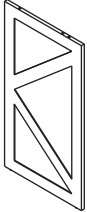
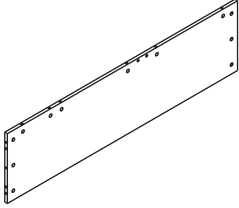
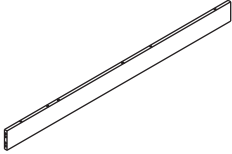
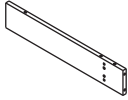

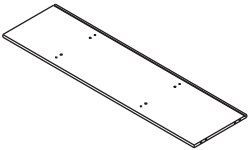
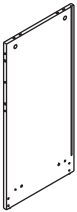



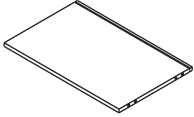
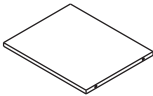
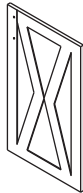

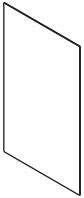
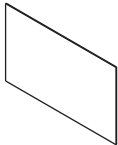
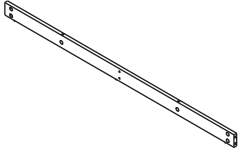
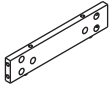
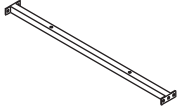
**⚠ Caution**

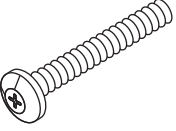
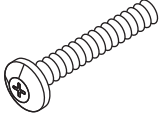

Make sure all parts are included. Most board parts are labeled or stamped on the raw edge. Contact us for a free replacement if you encounter any damaged or missing parts.

# Parts List

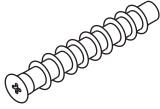
<p><b>1</b></p>  <p>1 pc</p>	<p><b>2</b></p>  <p>1 pc</p>	<p><b>3</b></p>  <p>2 pcs</p>	<p><b>4</b></p>  <p>1 pc</p>	<p><b>5</b></p>  <p>1 pc</p>
<p><b>6</b></p>  <p>1 pc</p>	<p><b>7</b></p>  <p>1 pc</p>	<p><b>8</b></p>  <p>1 pc</p>	<p><b>9</b></p>  <p>1 pc</p>	<p><b>10</b></p>  <p>1 pc</p>
<p><b>11</b></p>  <p>1 pc</p>	<p><b>12</b></p>  <p>1 pc</p>	<p><b>13</b></p>  <p>1 pc</p>	<p><b>14</b></p>  <p>1 pc</p>	<p><b>15</b></p>  <p>1 pc</p>
<p><b>16</b></p>  <p>1 pc</p>	<p><b>17</b></p>  <p>1 pc</p>	<p><b>18</b></p>  <p>1 pc</p>	<p><b>19</b></p>  <p>1 pc</p>	<p><b>20</b></p>  <p>1 pc</p>
<p><b>21</b></p>  <p>1 pc</p>	<p><b>22</b></p>  <p>2 pcs</p>	<p><b>23</b></p>  <p>2 pcs</p>	<p><b>24</b></p>  <p>1 pc</p>	<p><b>25</b></p>  <p>1 pc</p>
<p><b>26</b></p>  <p>8 pcs</p>				

# Hardware List

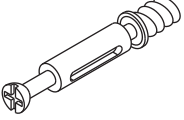
A	B	C	D	E	F
					
M6x40mm	M6x35mm	M6x12mm	Ø5x38mm	Ø4x18mm	Ø3.5x14mm
6 pcs	2 pcs	20 pcs	4 pcs	2 pcs	28 pcs

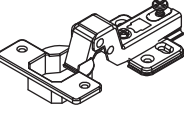
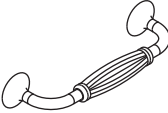
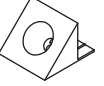
G	H	I	J	K	L
					
M6x44.5mm	Ø15x11.3mm	Ø8x30mm			
78 pcs	78 pcs	48 pcs	2 pcs	1 pc	16 pcs

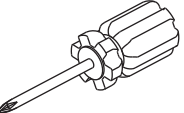
M					
					
Ø5x54mm					
1 pc					

# Installation of Cams and Pins

Read each step carefully before starting. Each step of instruction should be performed in the correct order. If these steps are not followed in sequence, assembly difficulties may occur.

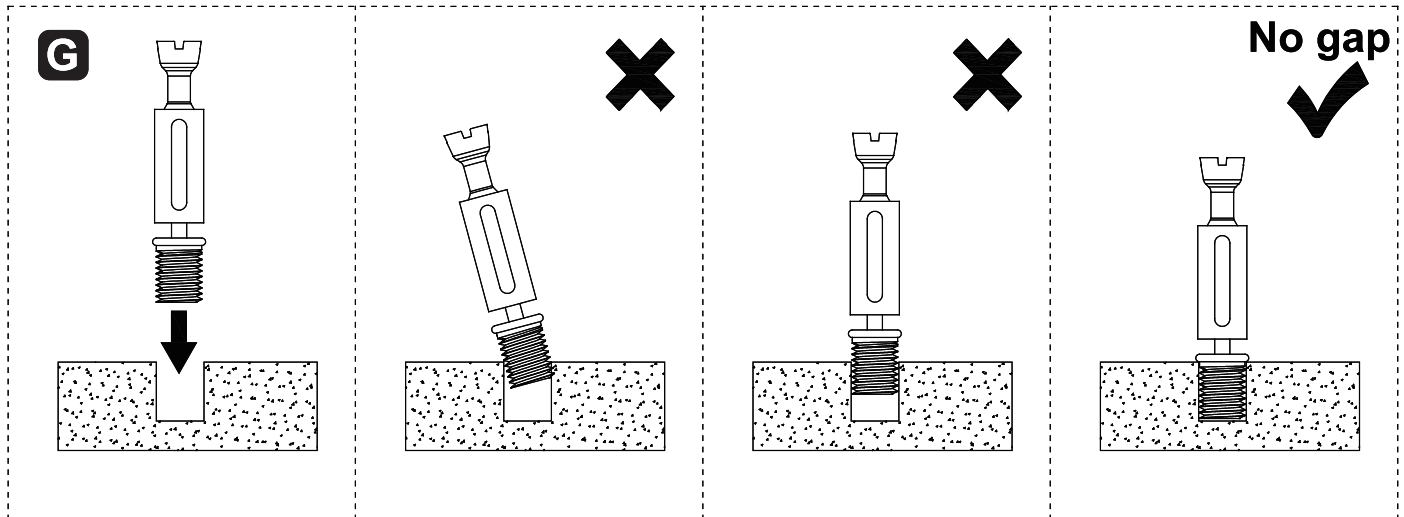

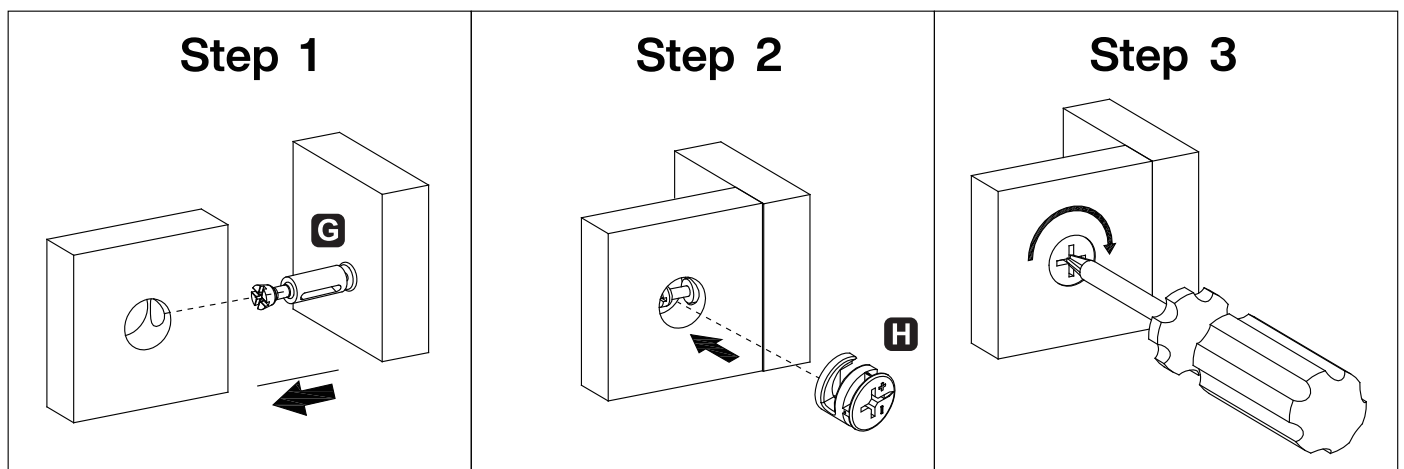

Screw the pin into the hole. Set the cams correctly by aligning the head of the cams with the lock pins. Lock the cam by turning the cam head with a screwdriver until it is tightened. Please do not use an electric screwdriver to assemble the unit.

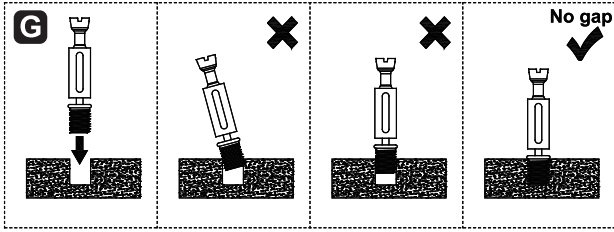

1

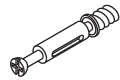

G	I
	
M6x44.5mm	Ø8x30mm
3 pcs	2 pcs

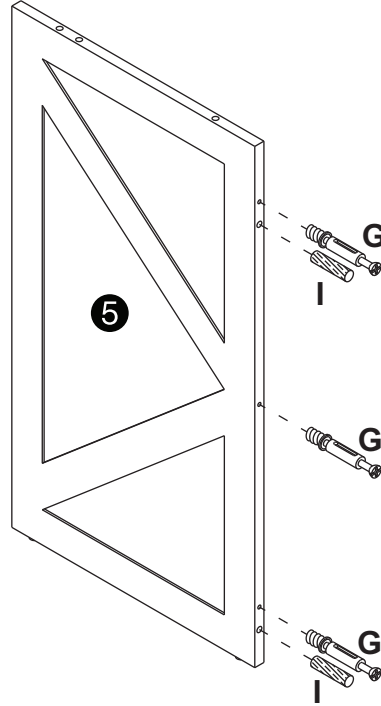

2

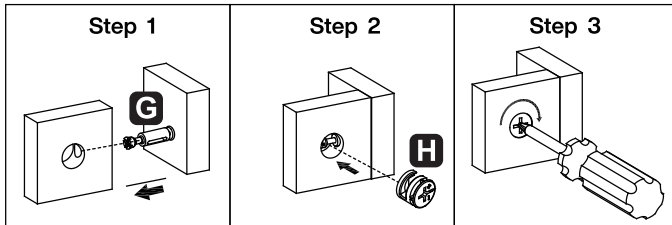

H

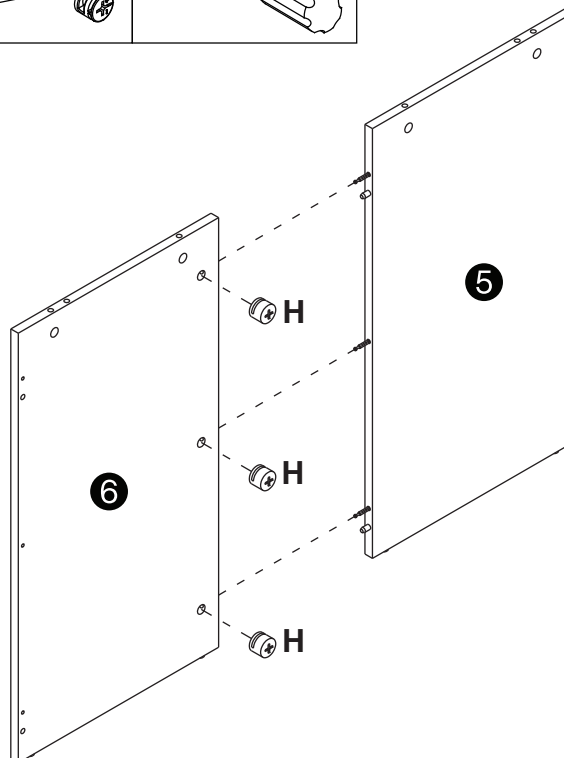
Ø15x11.3mm
3 pcs

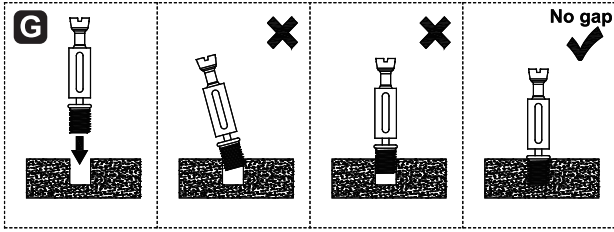

3

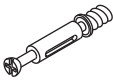

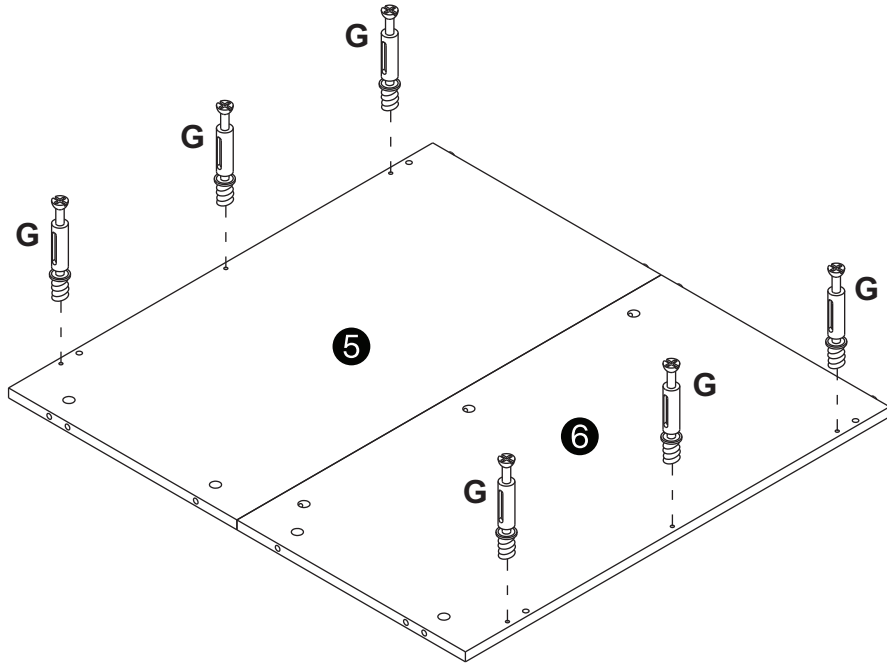
<b>G</b>

M6x44.5mm
6 pcs



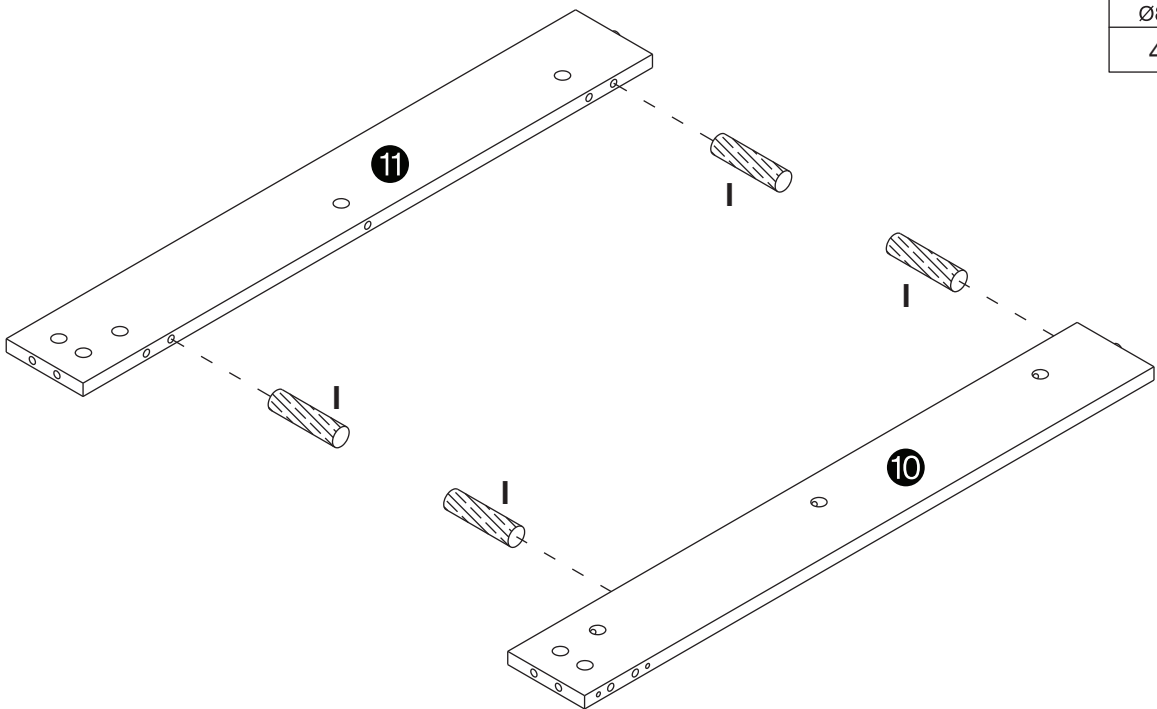

4

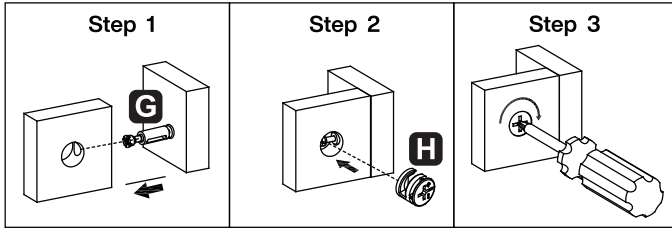

<b>I</b>

Ø8x30mm
4 pcs

**5**



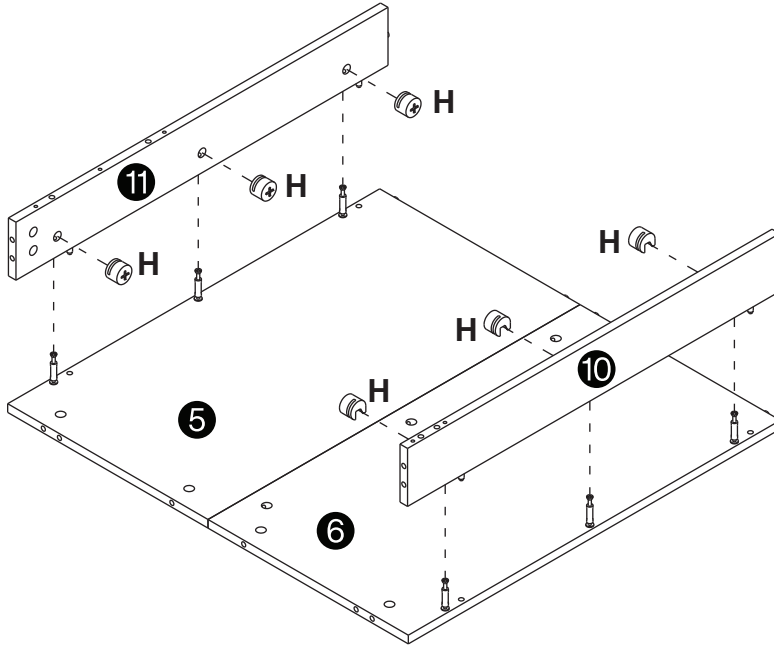

<b>H</b>

Ø15x11.3mm
6 pcs

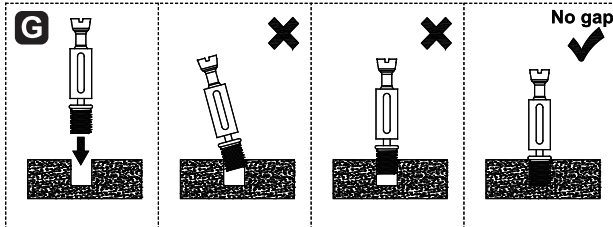

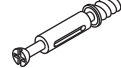
**6**

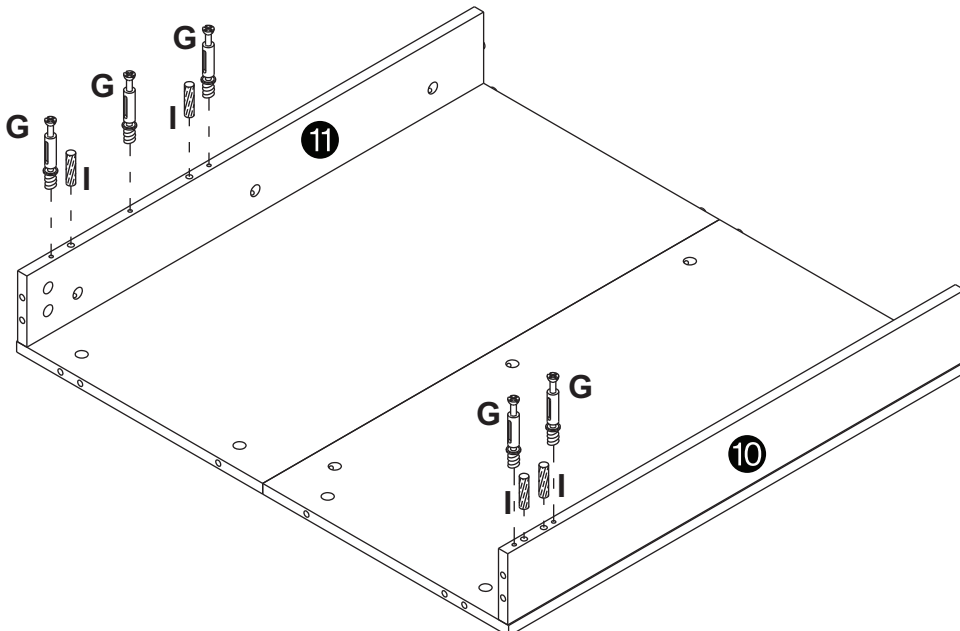

<b>G</b>	<b>I</b>
	
M6x44.5mm	Ø8x30mm
5 pcs	4 pcs



7

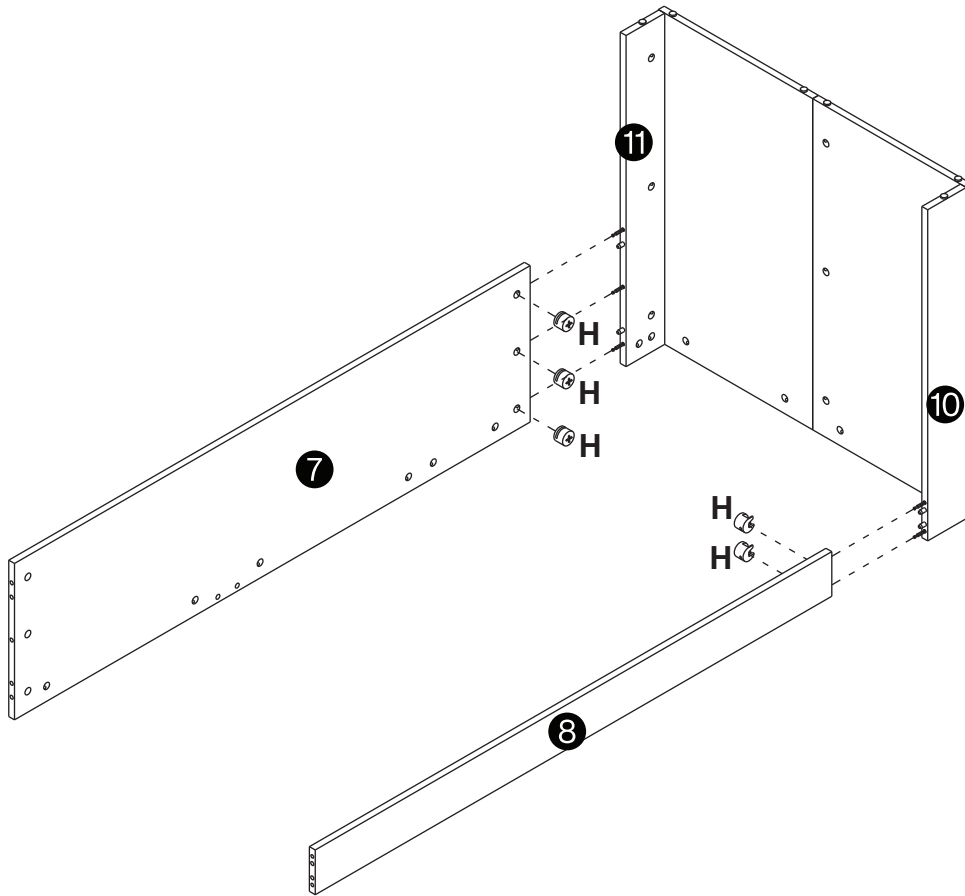

<b>H</b>

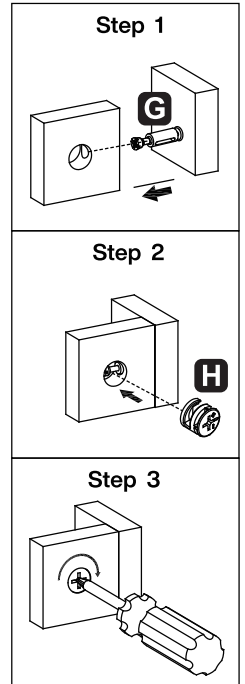
Ø15x11.3mm
5 pcs

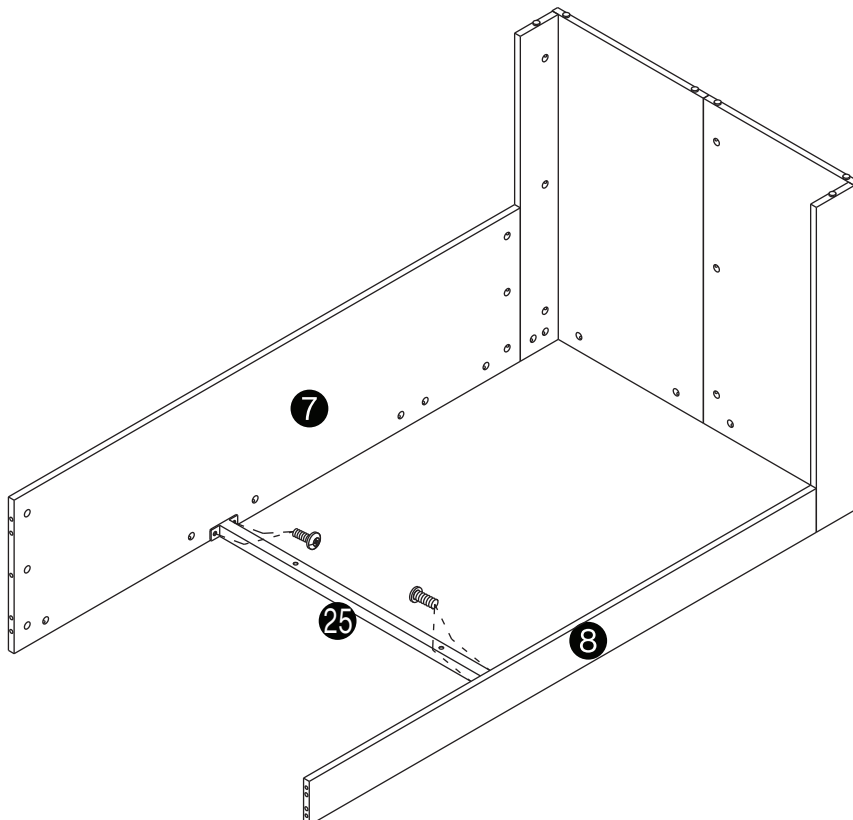

8

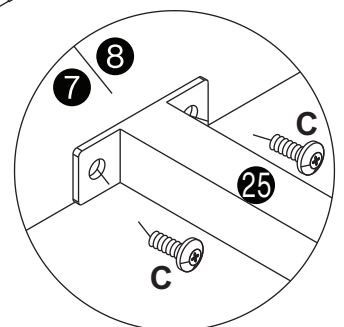

<b>C</b>

M6x12mm
4 pcs

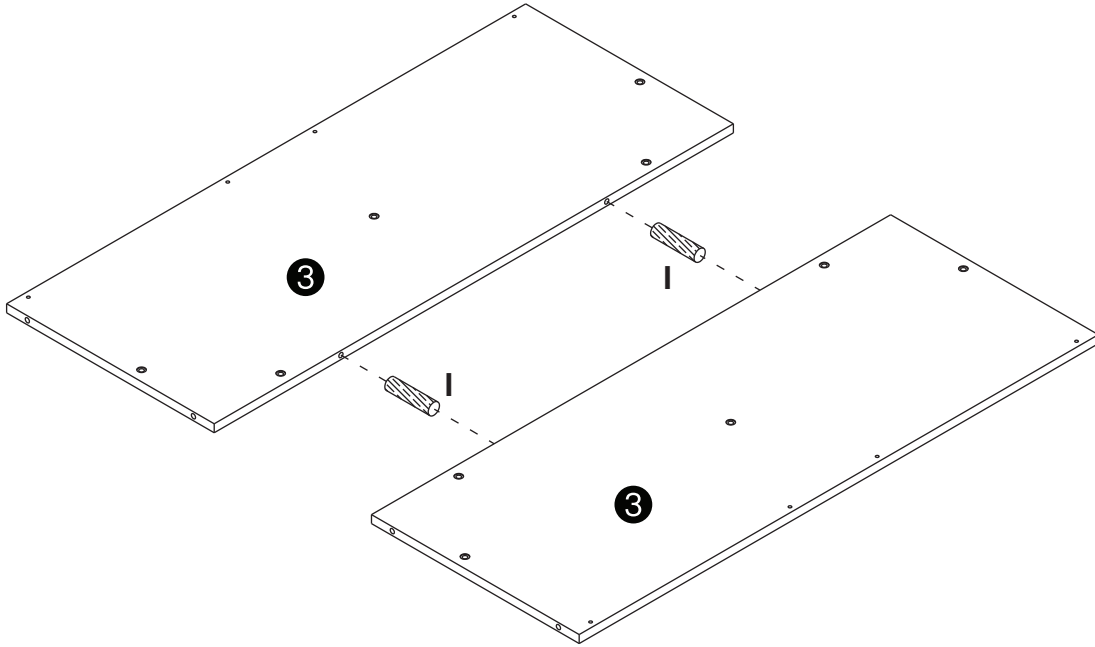

9

I

Ø8x30mm
2 pcs

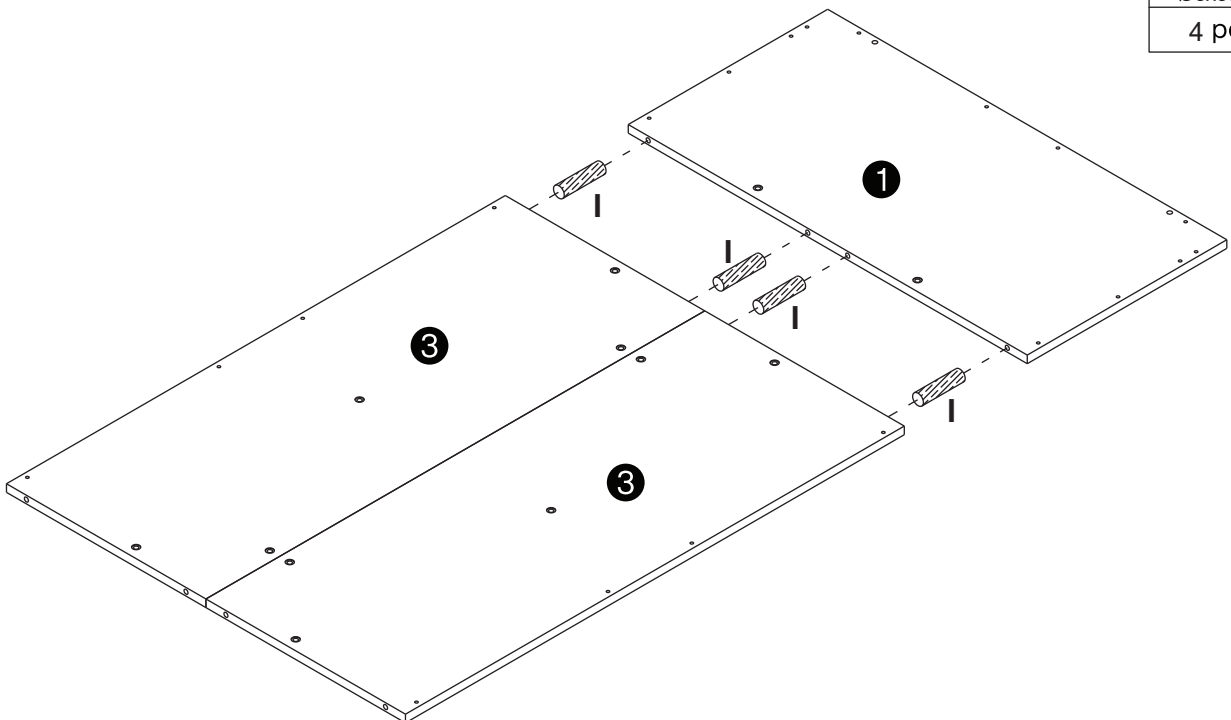

10

I

Ø8x30mm
4 pcs

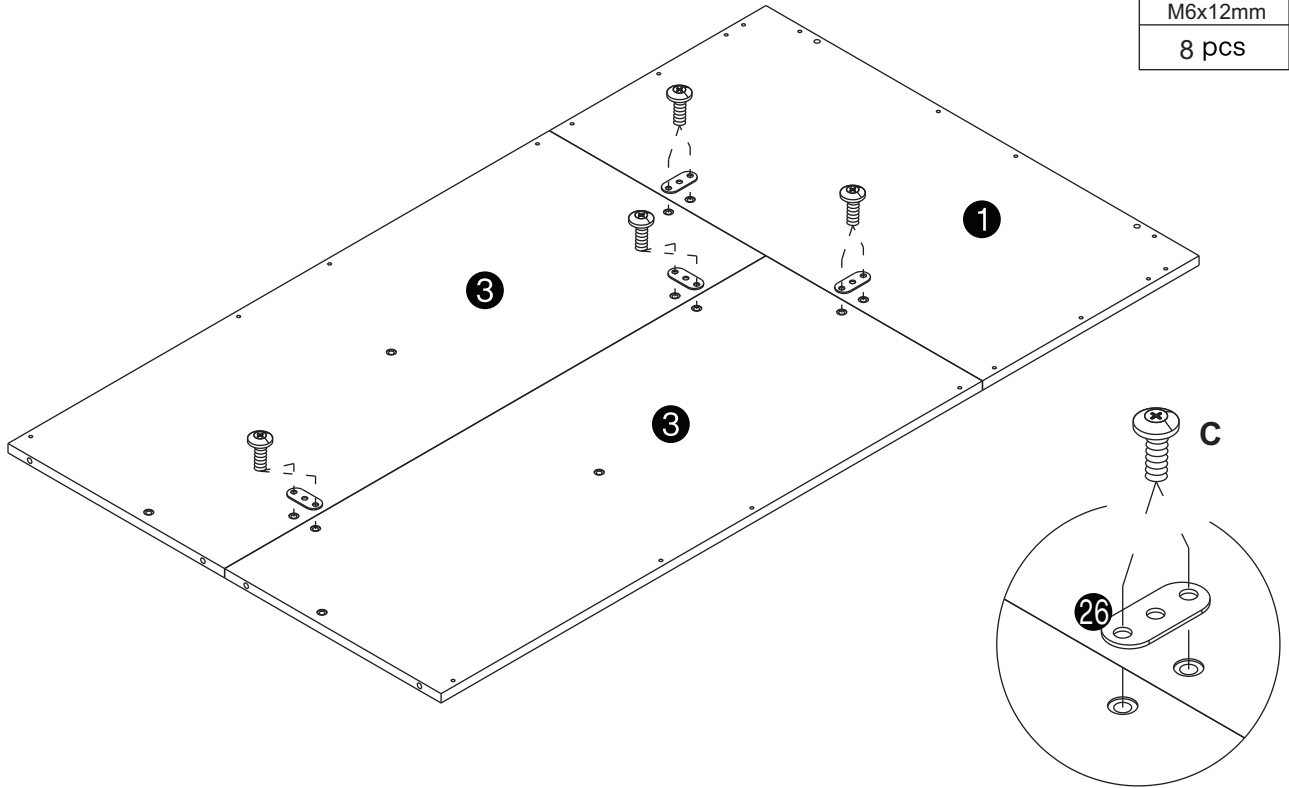

11

<b>C</b>

M6x12mm
8 pcs

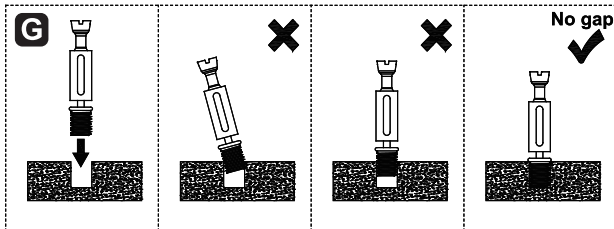

12

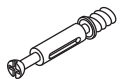

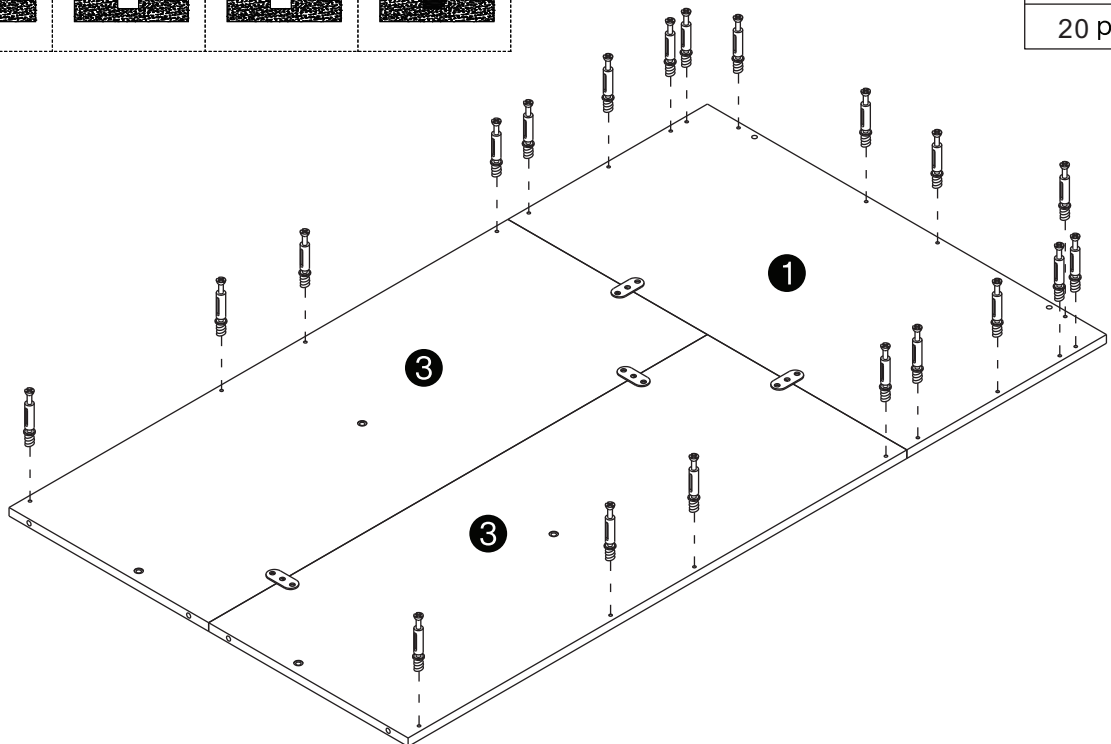
<b>G</b>

M6x44.5mm
20 pcs



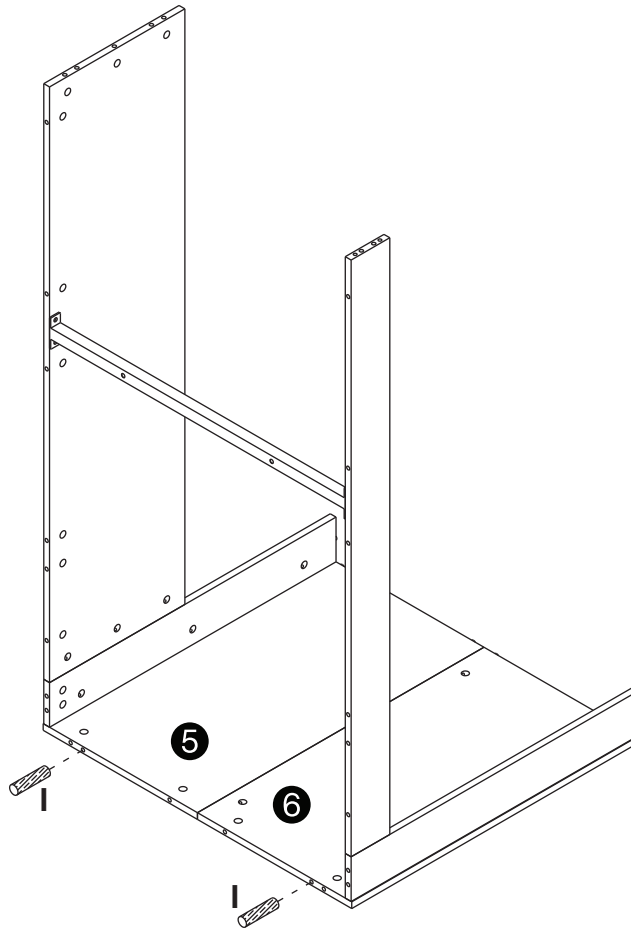

13

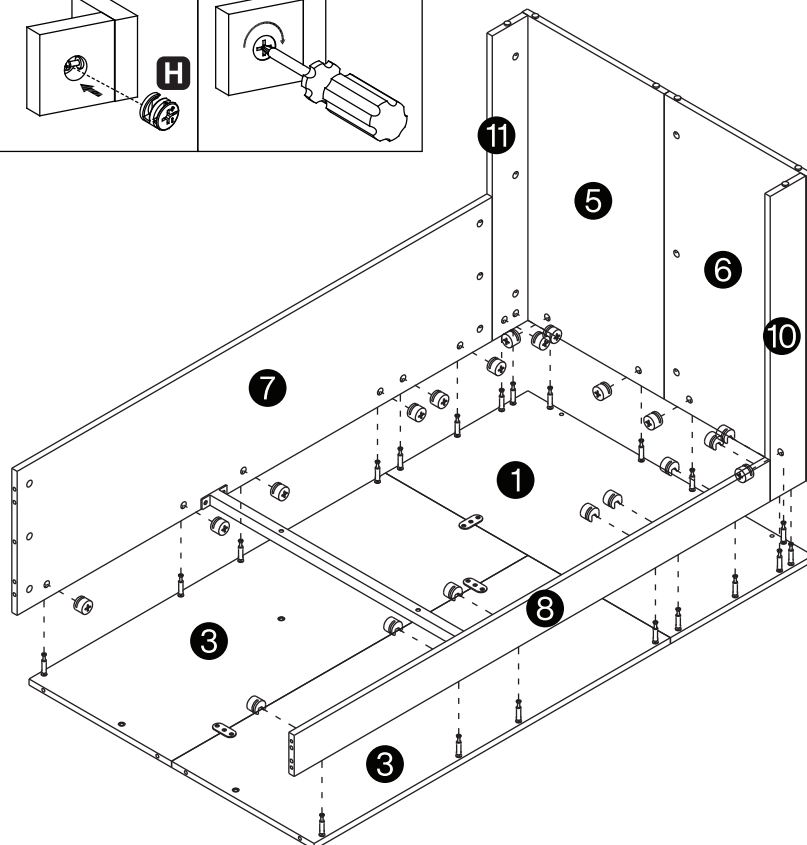
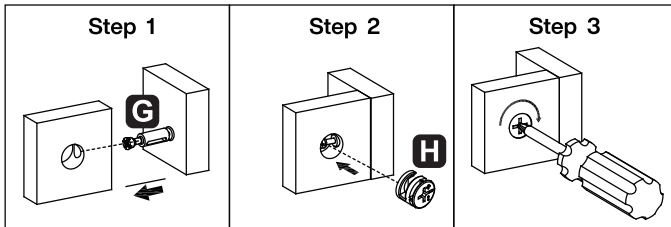

I

Ø8x30mm
2 pcs



14

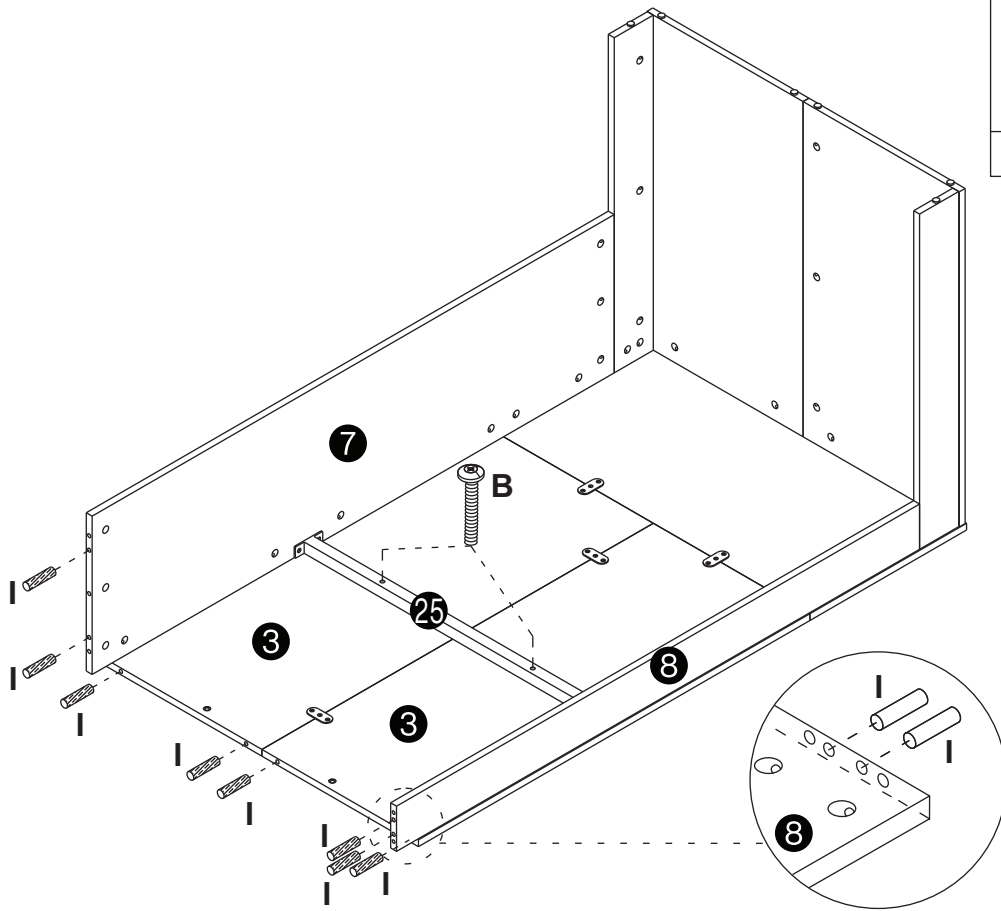

H

Ø15x11.3mm
20 pcs

15



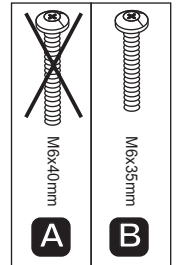

B	I
	
M6x35mm	Ø8x30mm
2 pcs	8 pcs

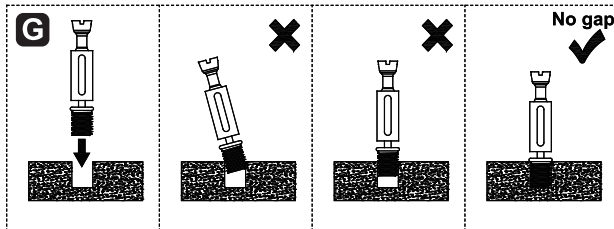

16

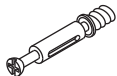

G	I
	
M6x44.5mm	Ø8x30mm
4 pcs	8 pcs

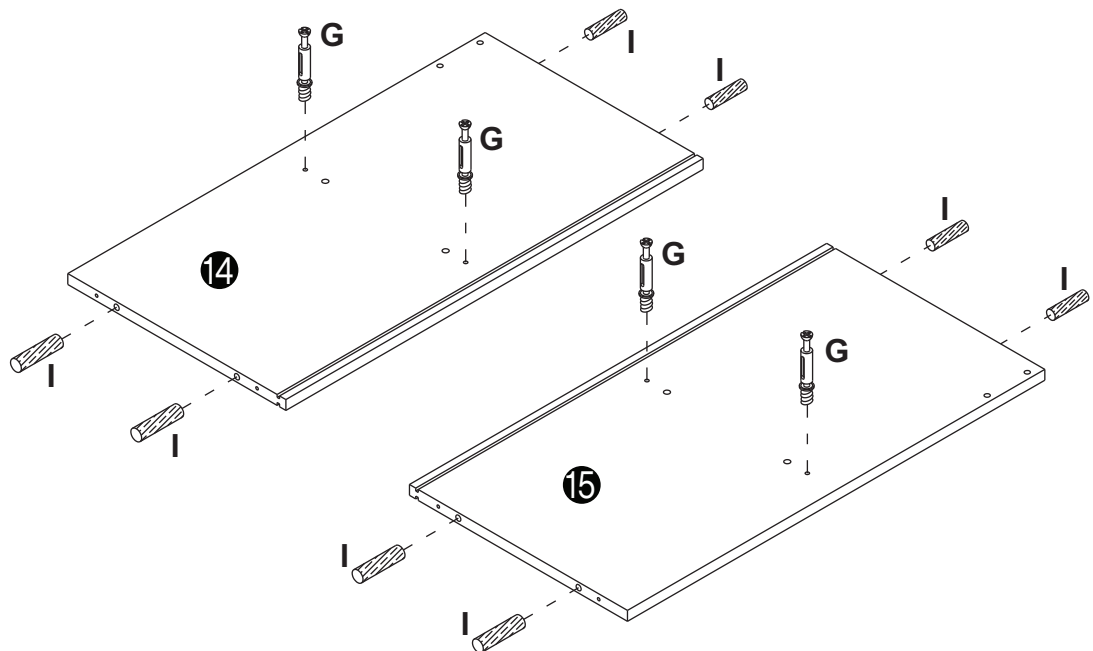

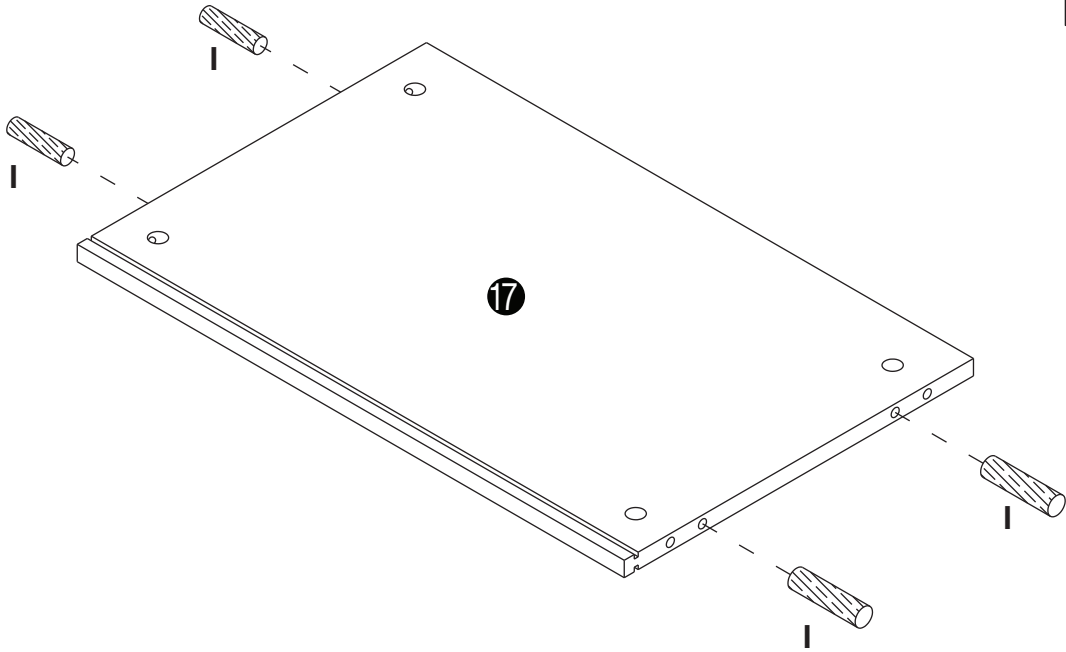

17

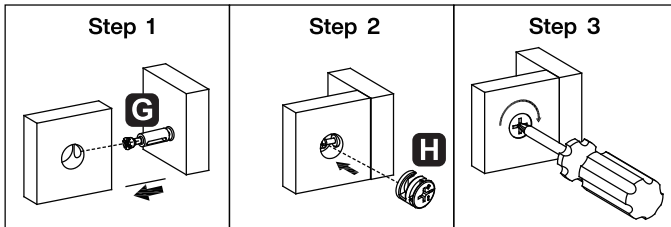

I

Ø8x30mm
4 pcs

18

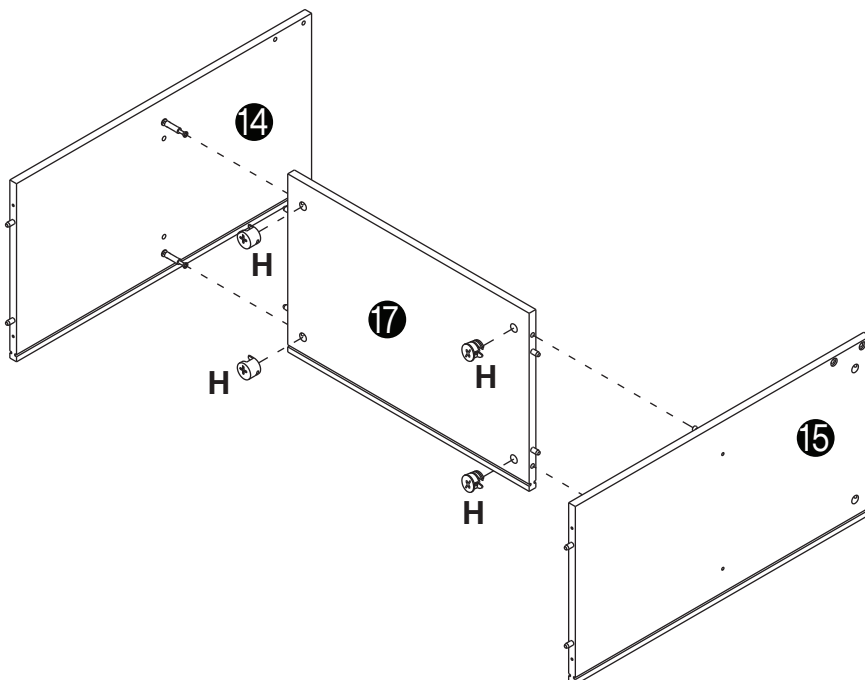

H

Ø15x11.3mm
4 pcs

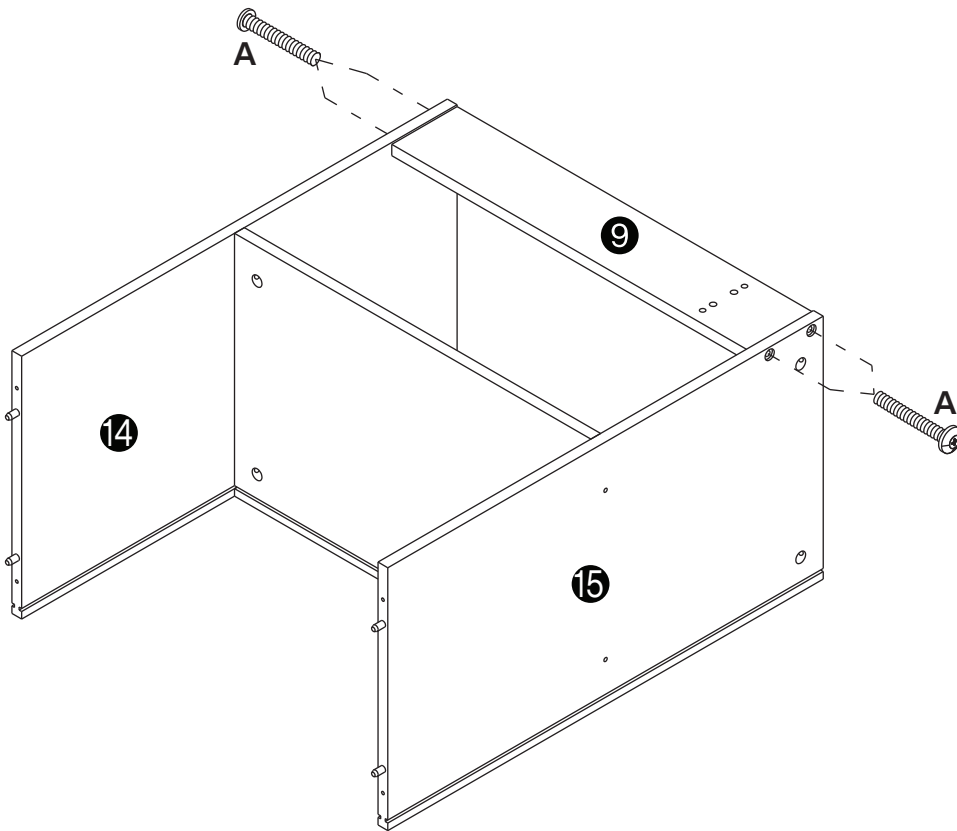

19

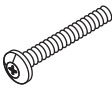

A

M6x40mm
4 pcs

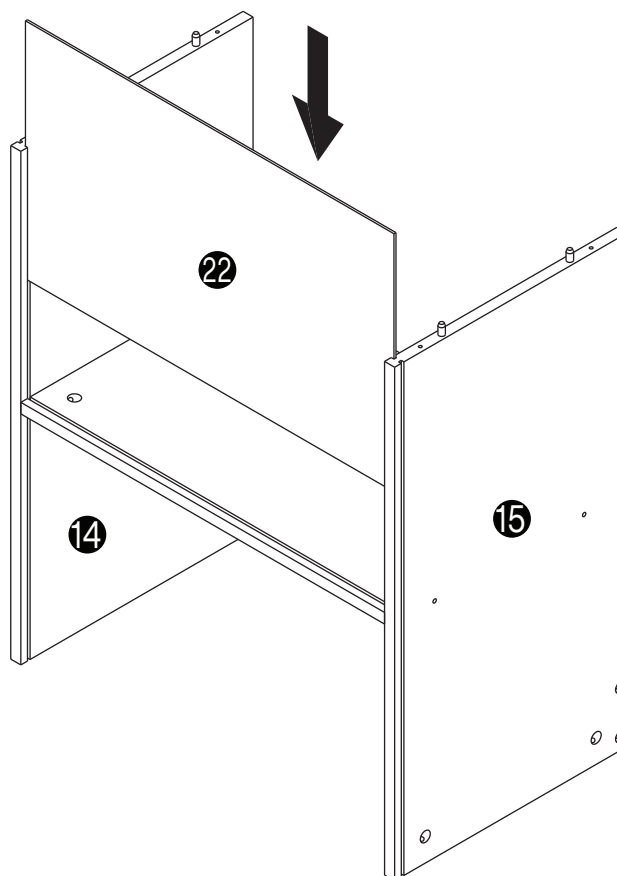
20



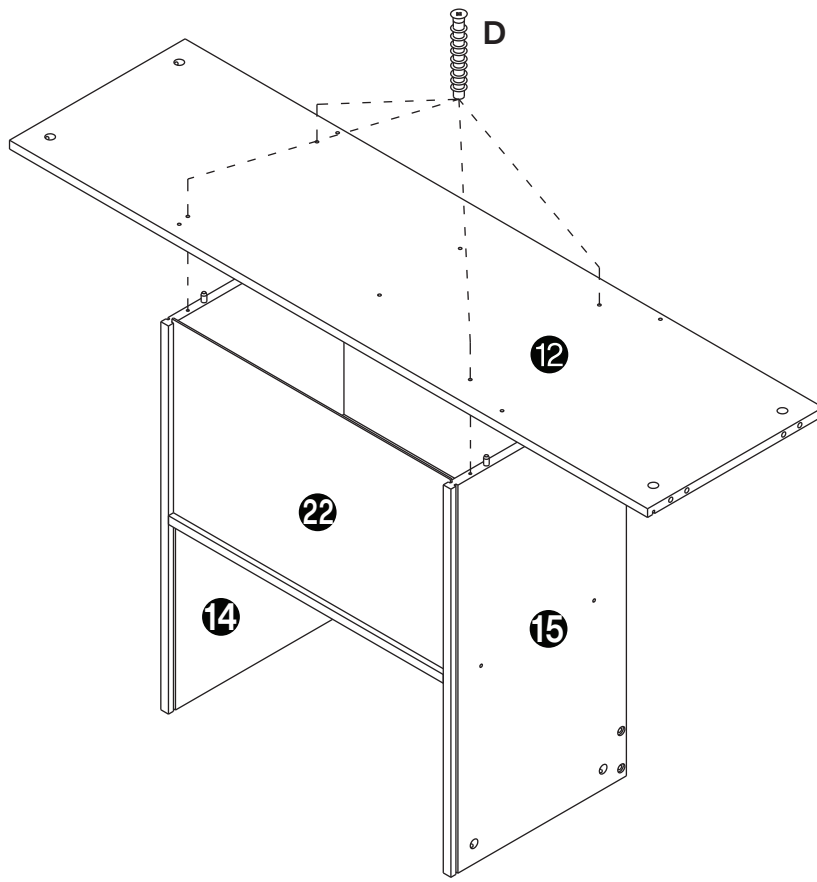

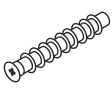
21

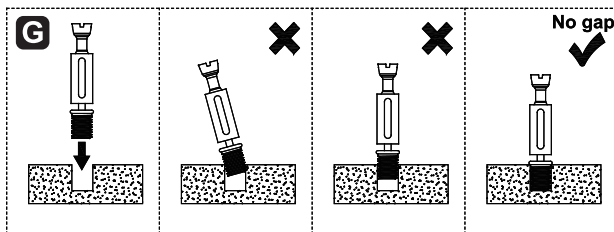

D

Ø5x38mm
4 pcs

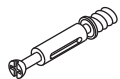
22

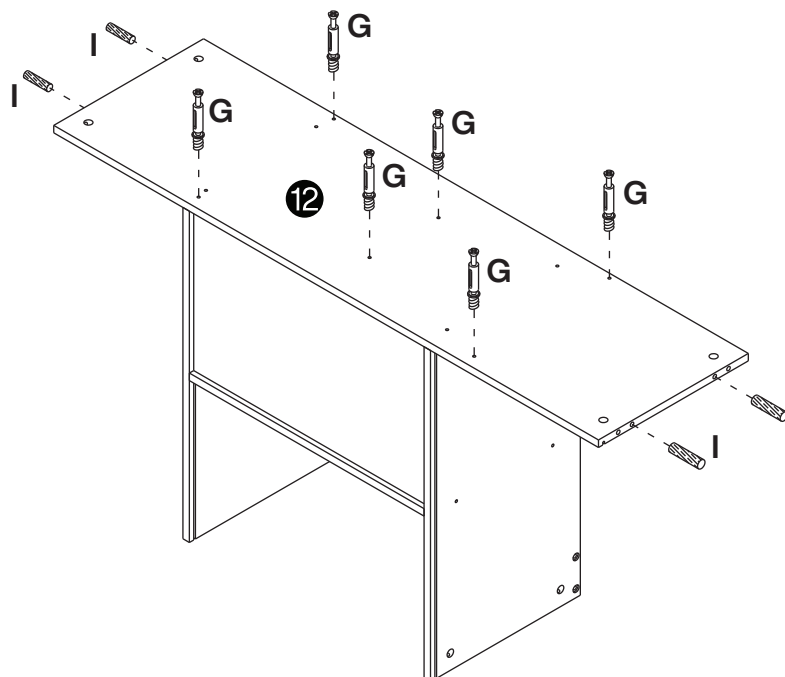

G	I
	
M6x44.5mm	Ø8x30mm
6 pcs	4 pcs



23

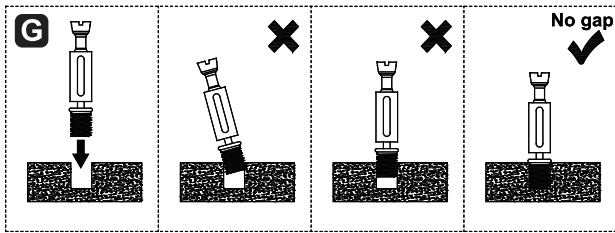

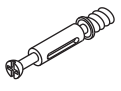

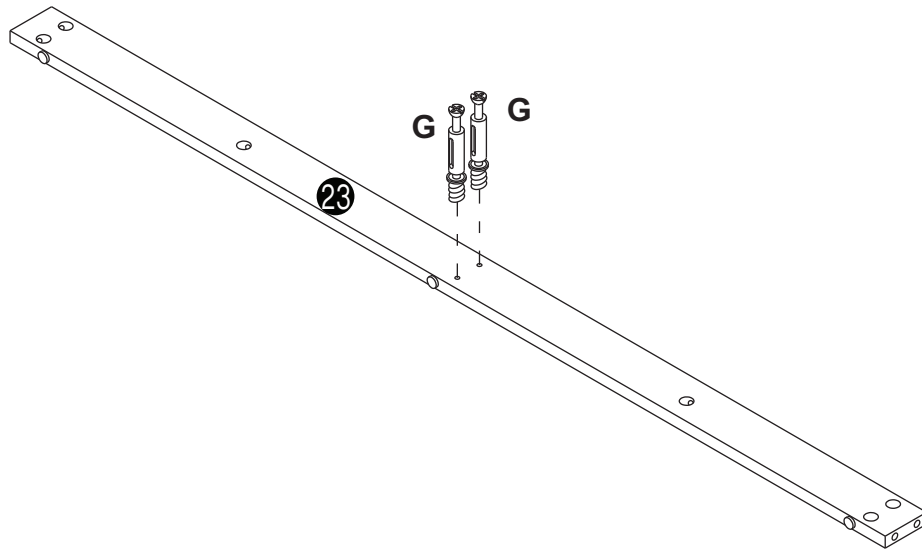
<b>G</b>

M6x44.5mm
4 pcs

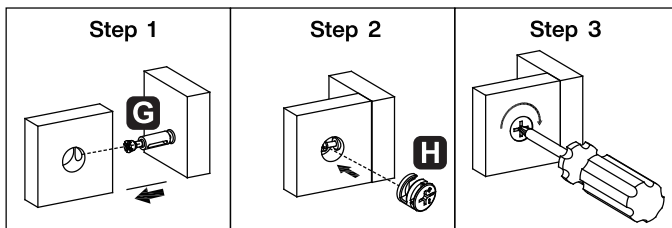

X2

24

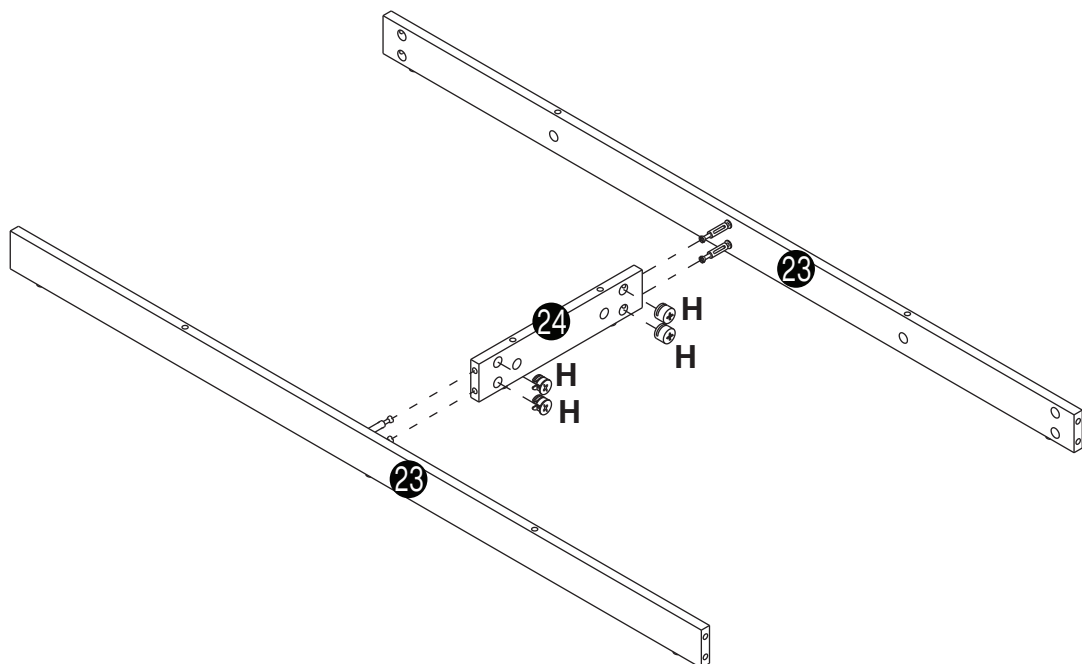

<b>H</b>

Ø15x11.3mm
4 pcs

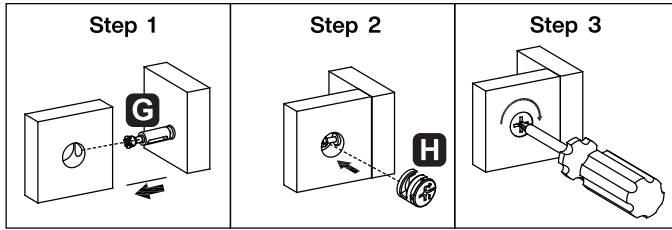

25



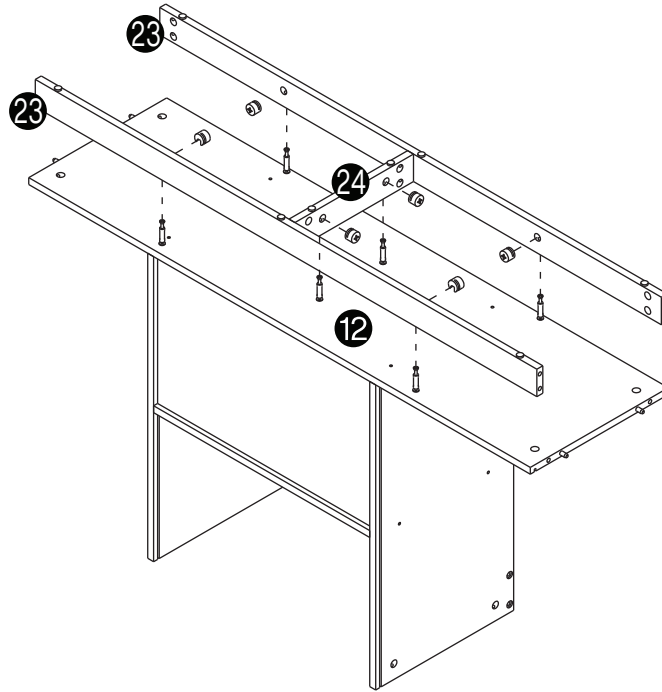

<b>H</b>

Ø15x11.3mm
6 pcs

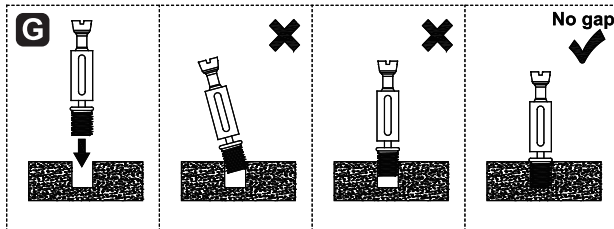

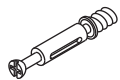
26

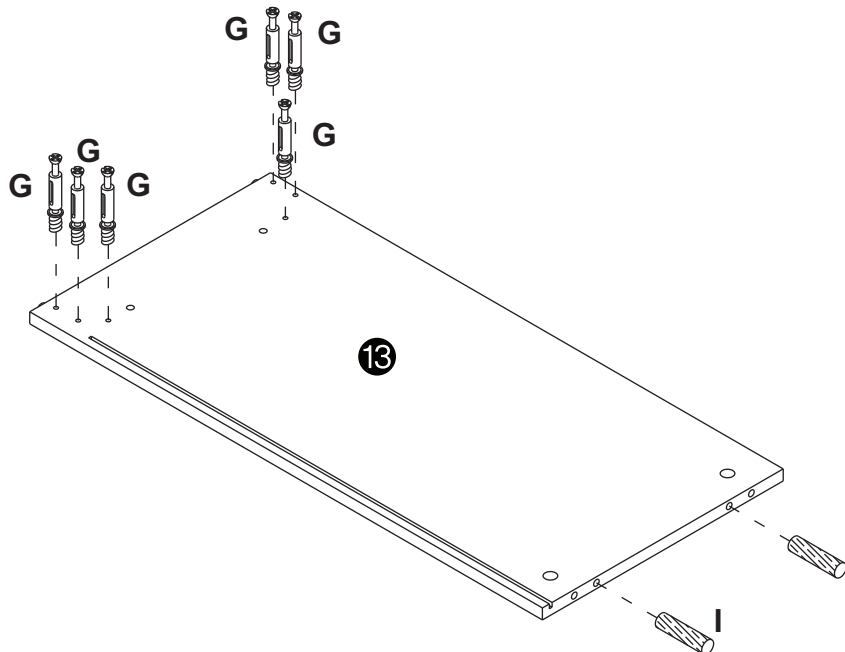

<b>G</b>	<b>I</b>
	
M6x44.5mm	Ø8x30mm
6 pcs	2 pcs



27

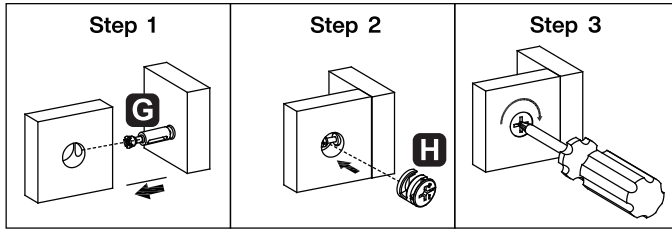

<b>H</b>

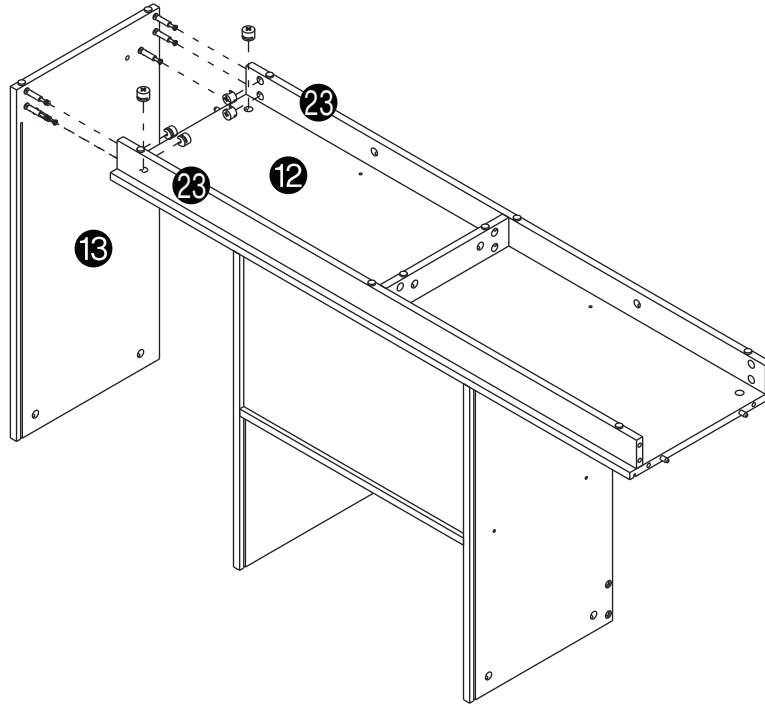
Ø15x11.3mm
6 pcs

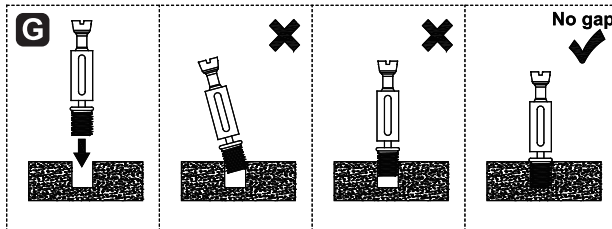

28

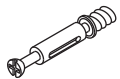

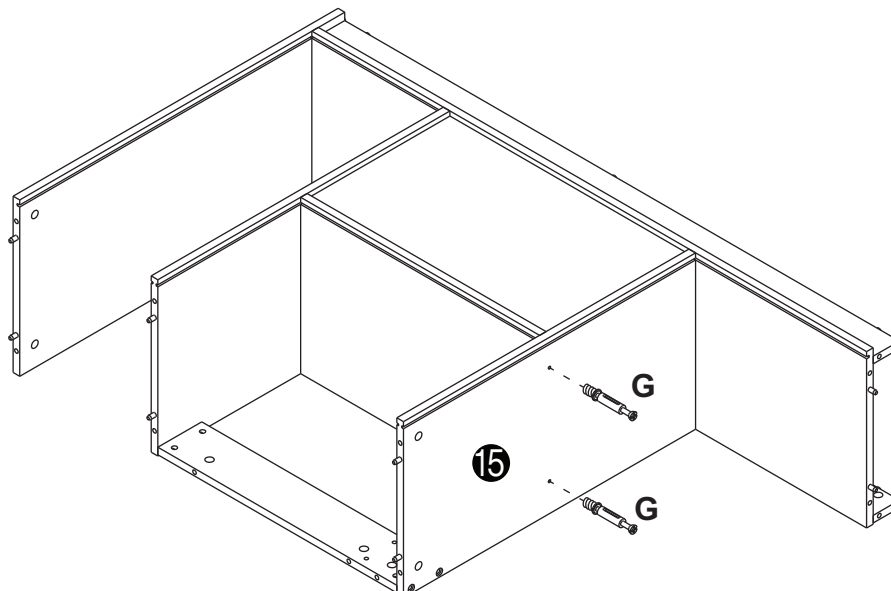
<b>G</b>

M6x44.5mm
2 pcs

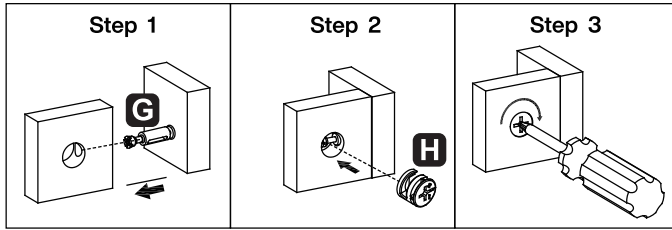

**29**



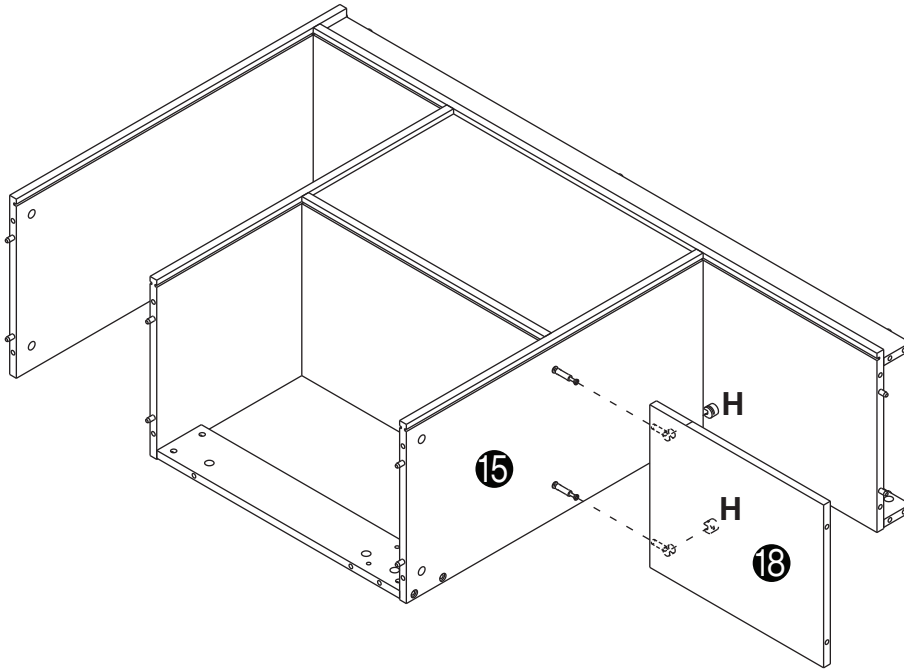

<b>H</b>

Ø15x11.3mm
2 pcs

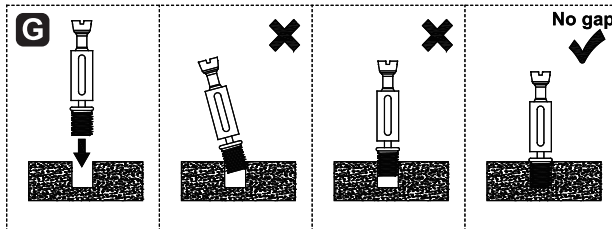

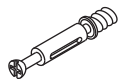
**30**

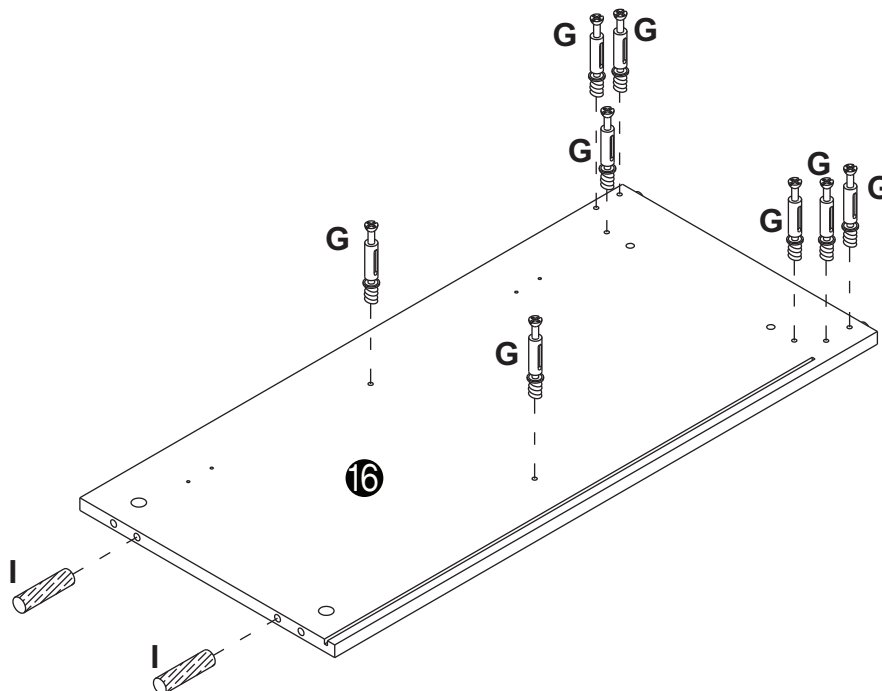

<b>G</b>	<b>I</b>
	
M6x44.5mm	Ø8x30mm
8 pcs	2 pcs



31

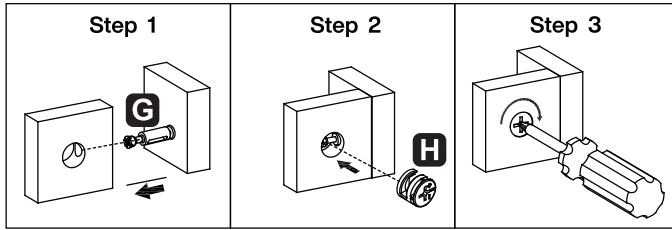

<b>H</b>

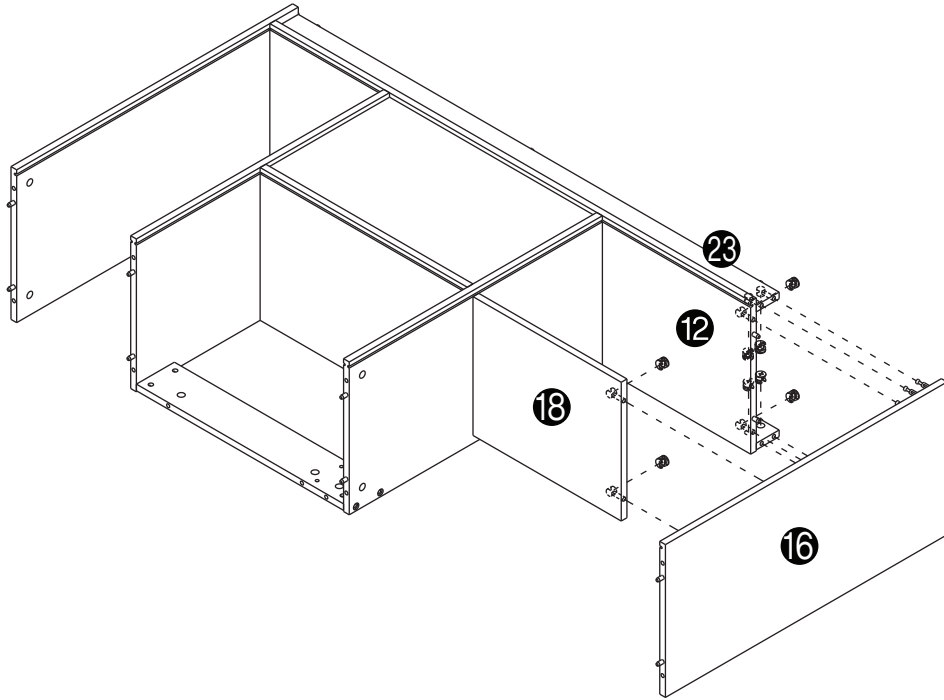
Ø15x11.3mm
8 pcs

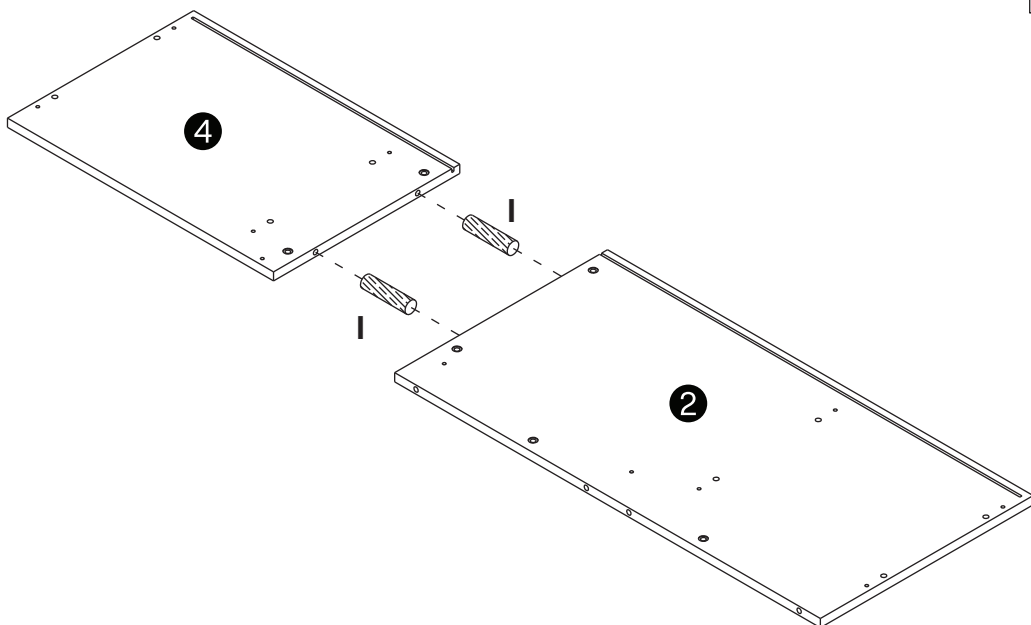

32



<b>I</b>

Ø8x30mm
6 pcs

33

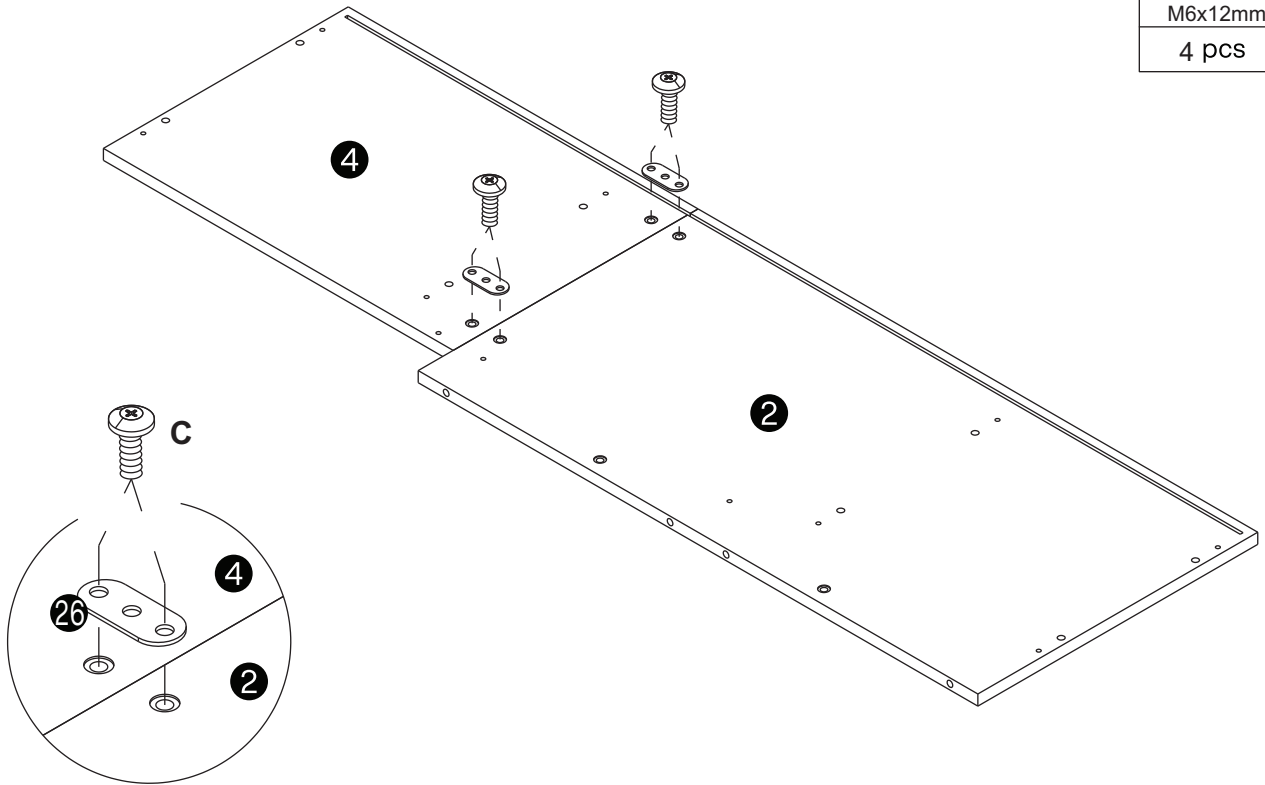
<b>C</b>

M6x12mm
4 pcs

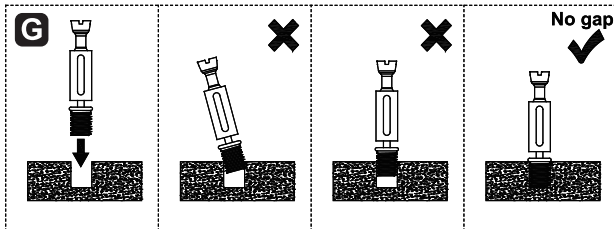

34

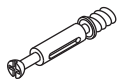

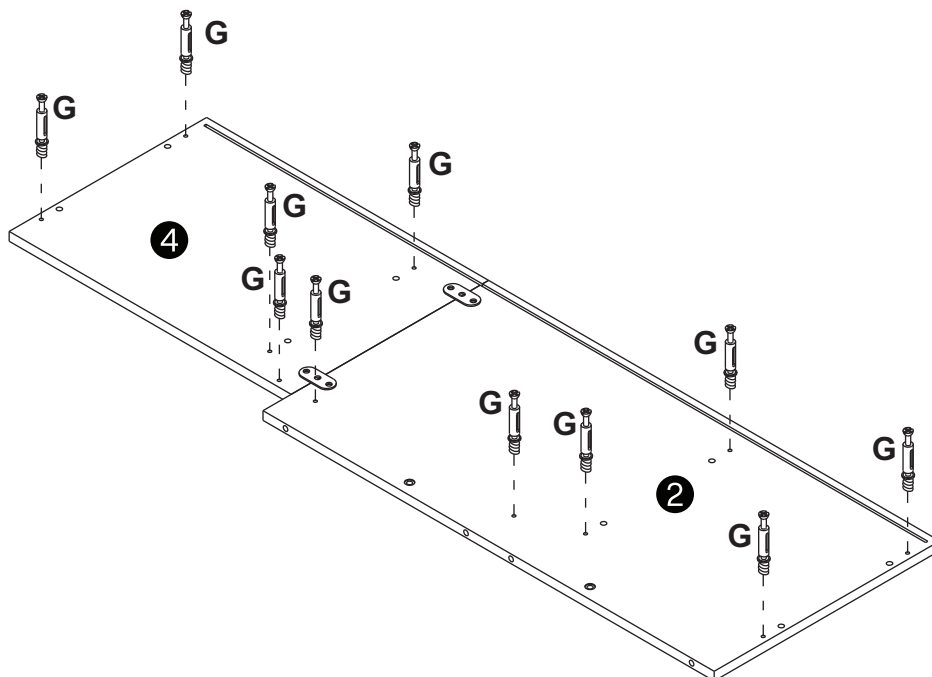
<b>G</b>

M6x44.5mm
11 pcs

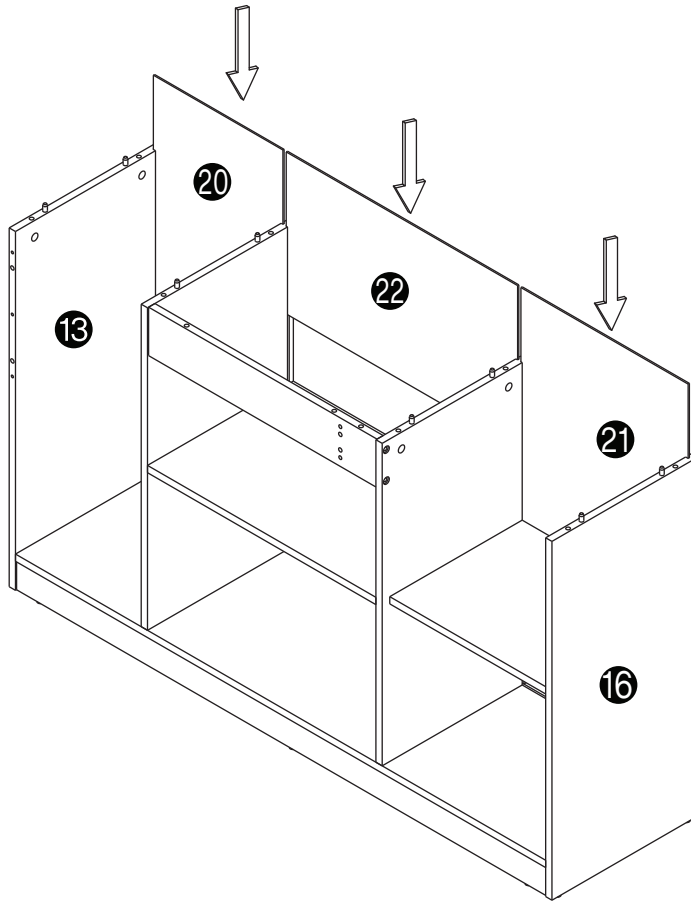

**35**



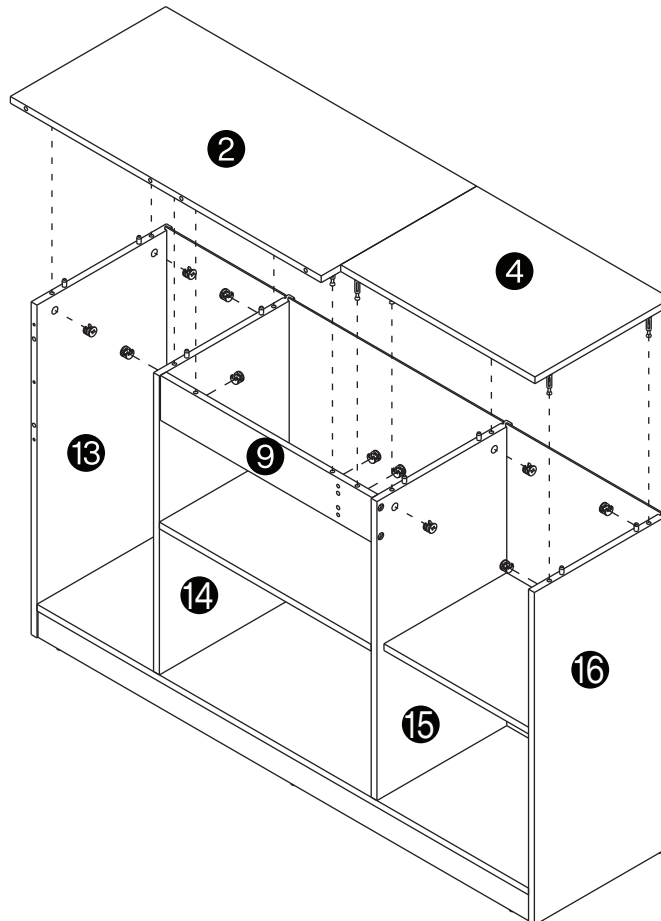
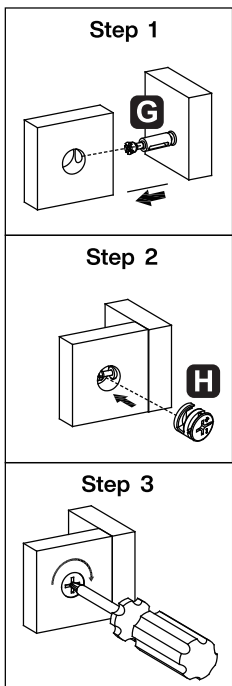

**36**



<b>H</b>

Ø15x11.3mm
11 pcs

37

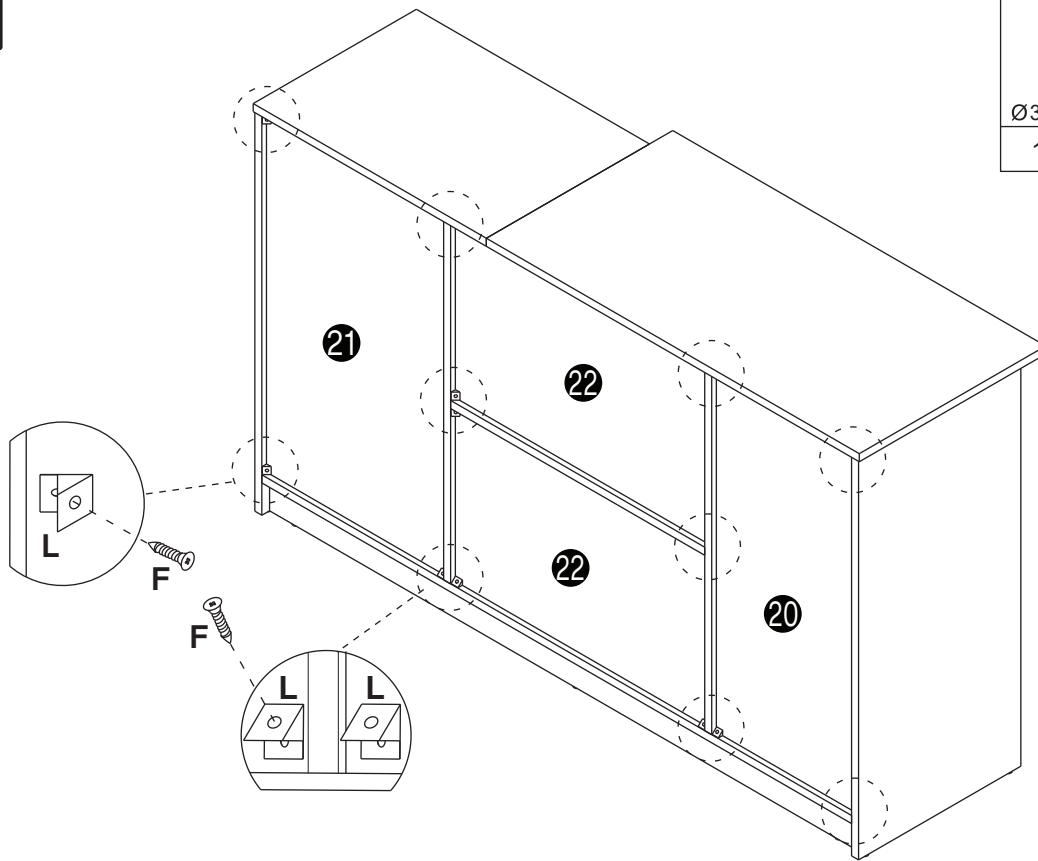
F	L
 Ø3.5x14mm	
16 pcs	16 pcs

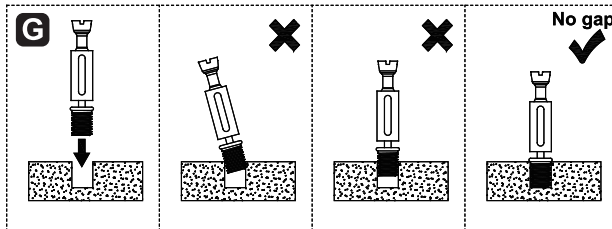

38

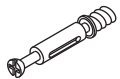

G
 M6x44.5mm
3 pcs

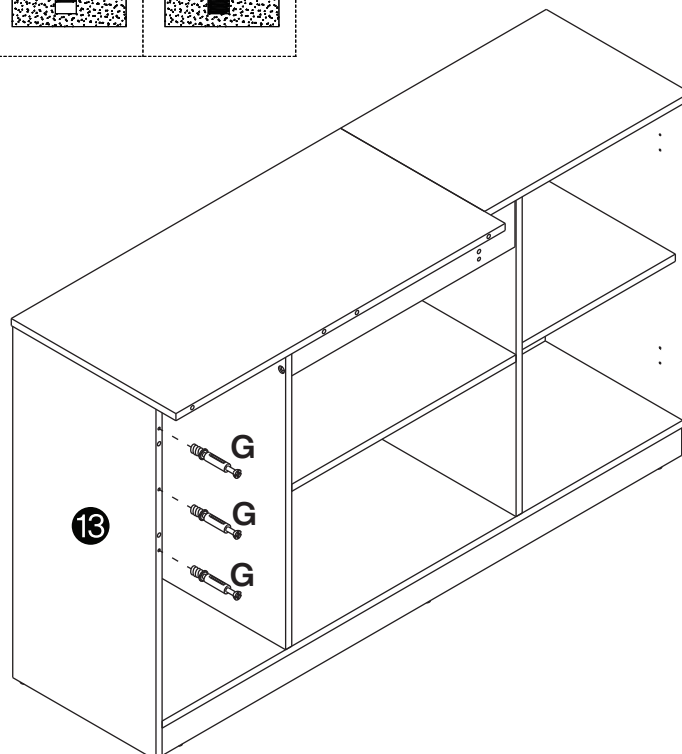

39

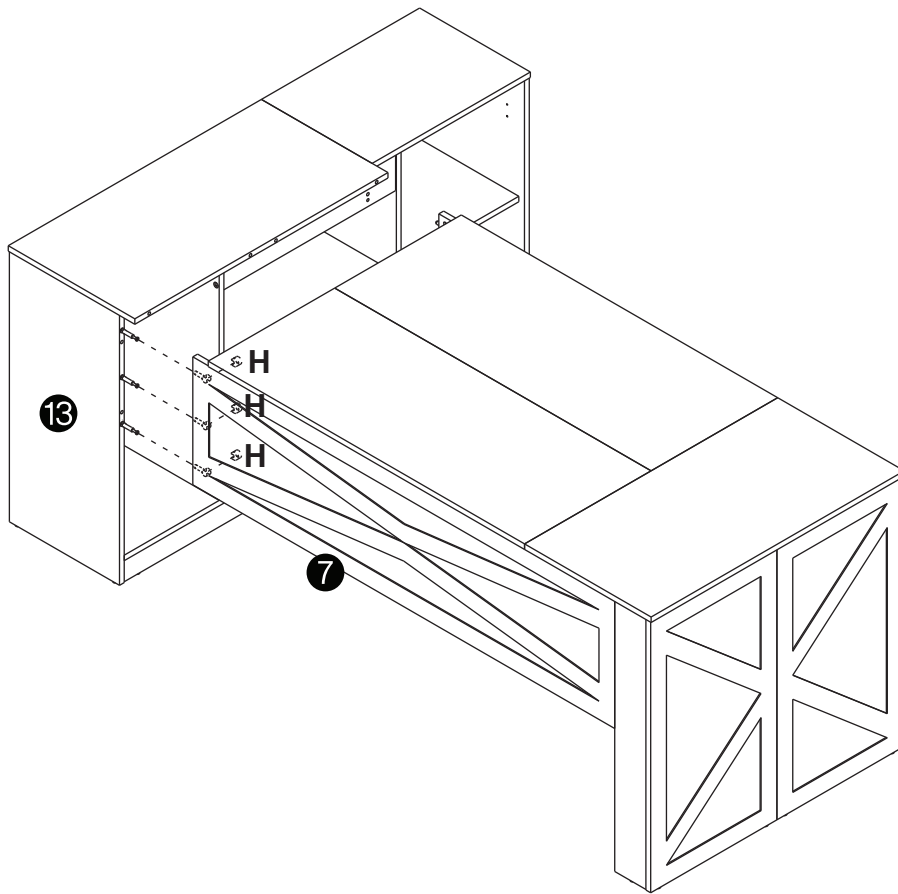

<b>H</b>
Ø15x11.3mm
3 pcs

**Step 1**

**Step 2**

**Step 3**

40

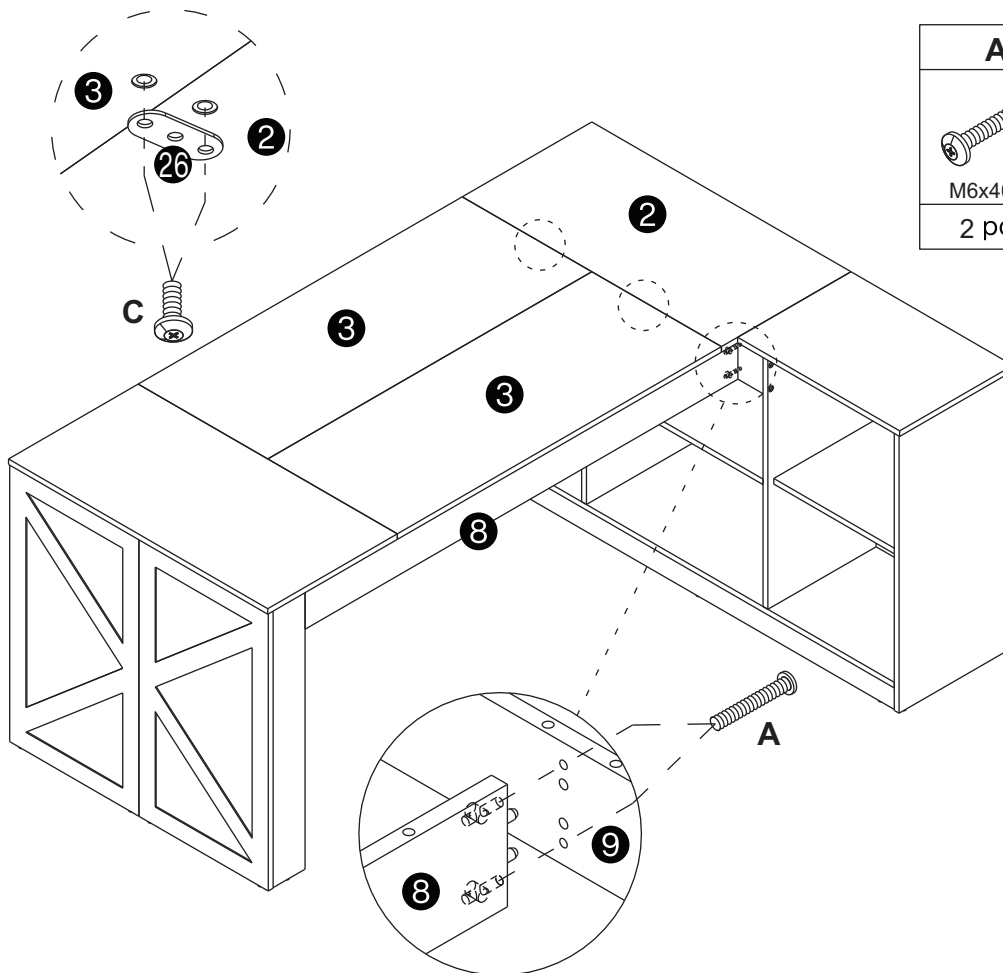

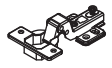

<b>A</b>	<b>C</b>
M6x40mm	M6x12mm
2 pcs	4 pcs

41

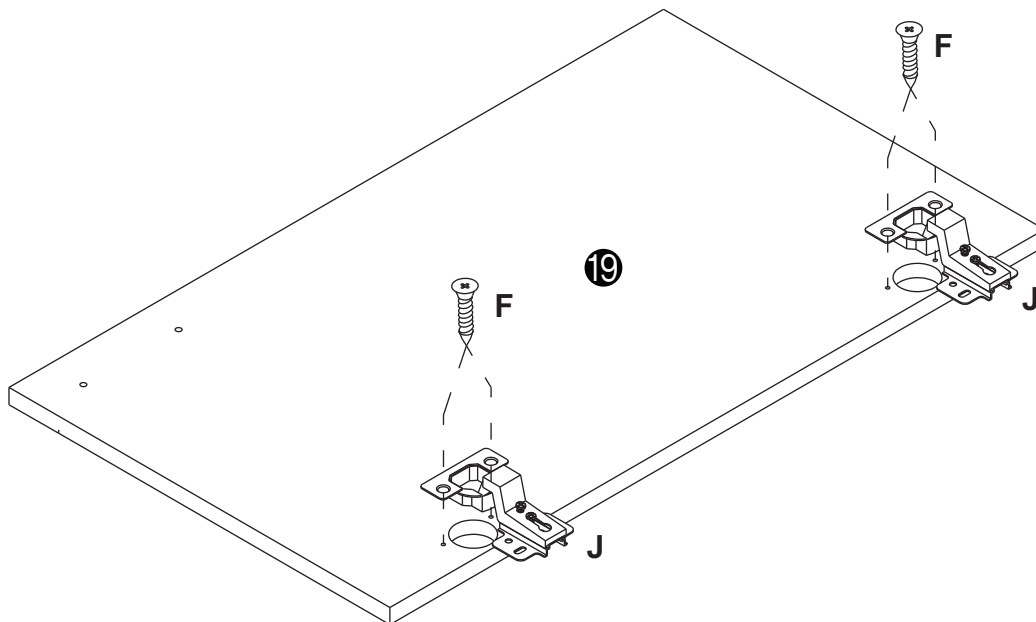
F	J
	
Ø3.5x14mm	
4 pcs	2 pcs



42

E	K
	
Ø4x18mm	
2 pcs	1 pc

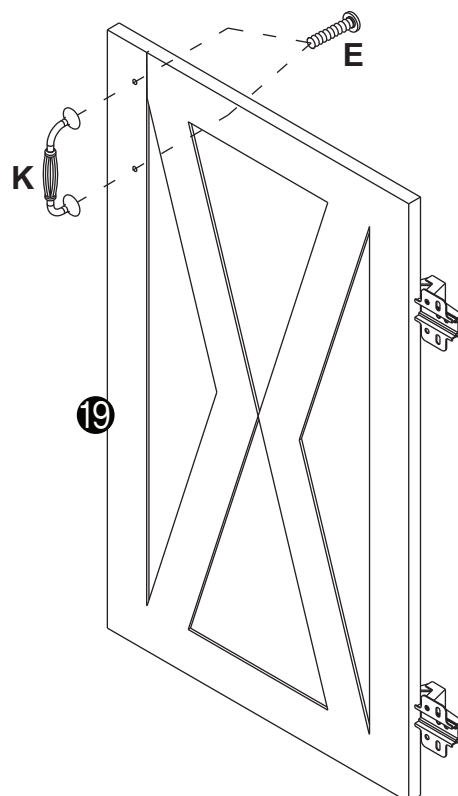

43

<b>F</b>

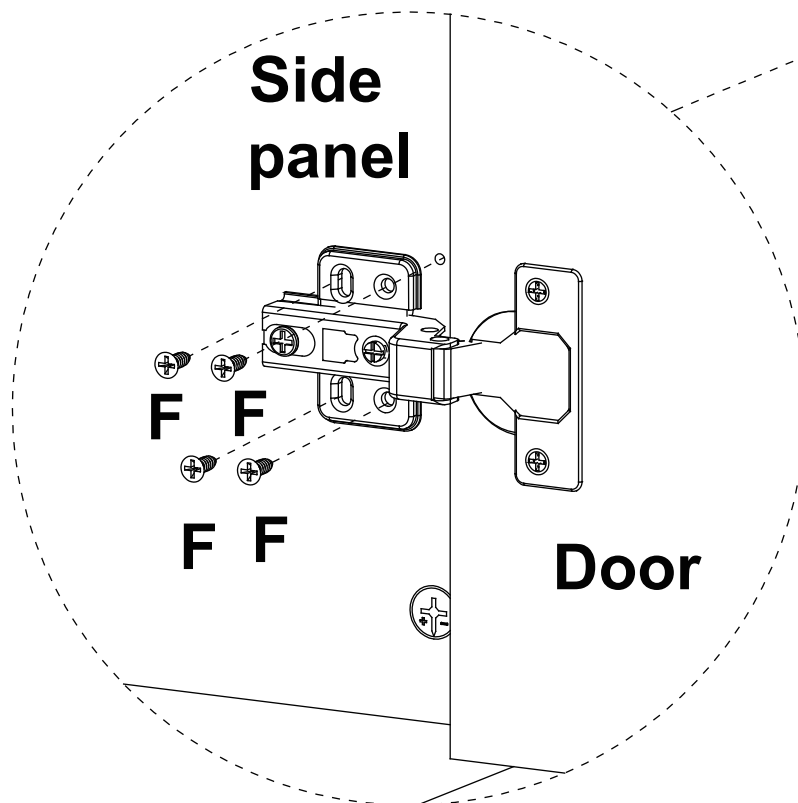
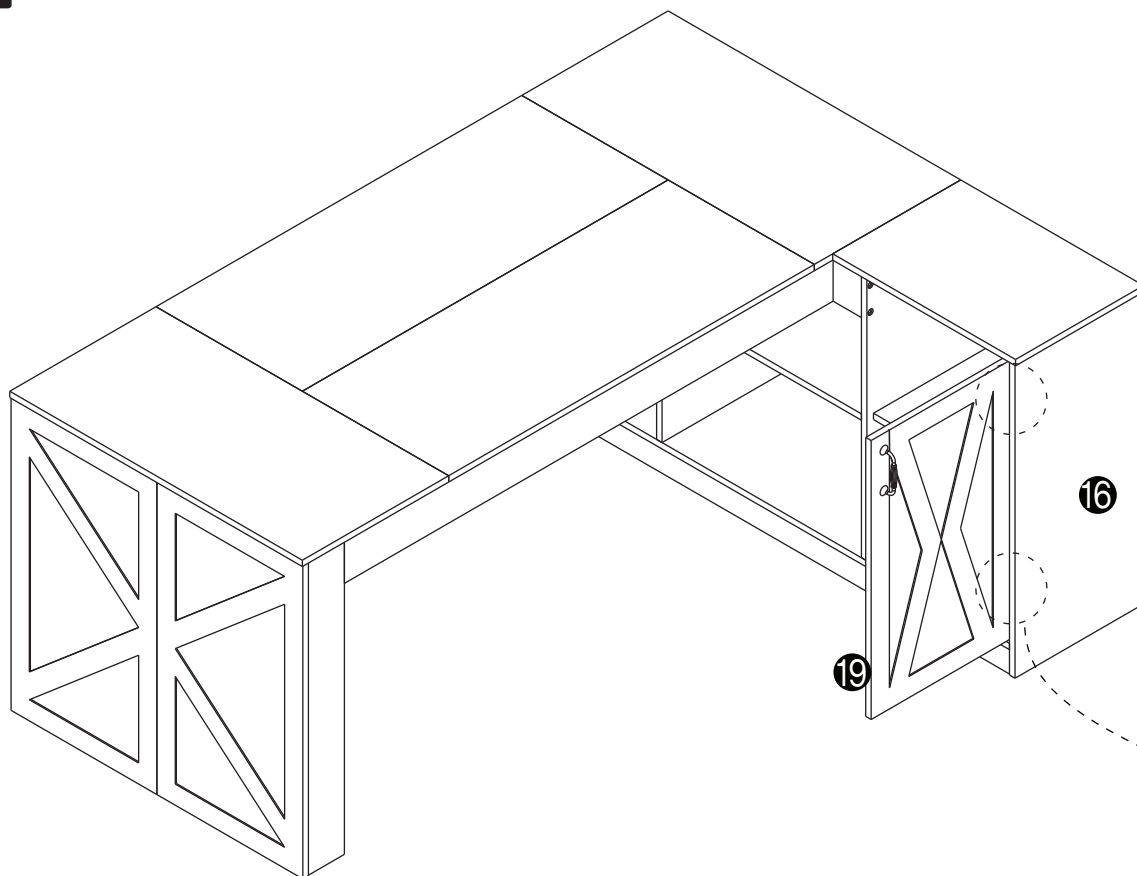
Ø3.5x14mm
8 pcs

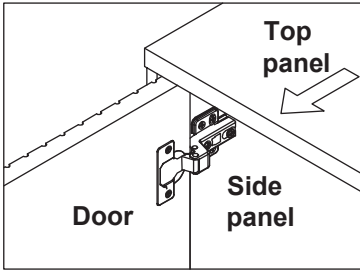

## Step 1

Open the door.



# ADJUST YOUR DOORS TO MAKE THE GAPS MORE EVEN (OPTIONAL).

## Step 2

Adjust the door panel to be flush with side panel and top panel edge.

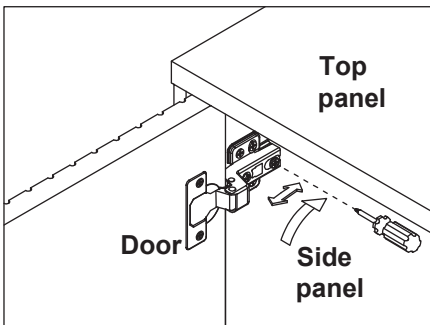

Loosen the screw indicated a little, adjust the hinge to the right position (see step 2a & 2b), then tighten the screw.

### Step 2a MOVE DOOR OUT

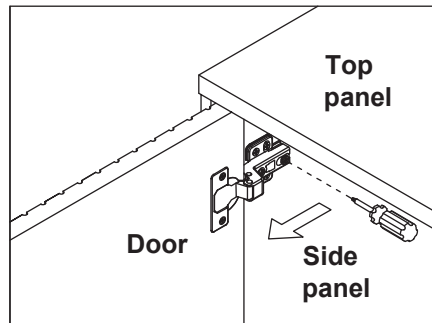
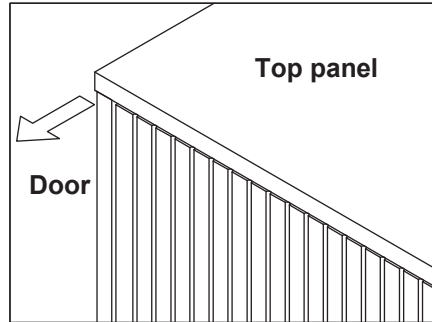

Pull the hinge forward a little.

### Step 2b MOVE DOOR IN

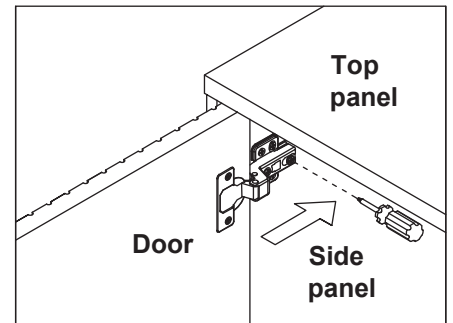
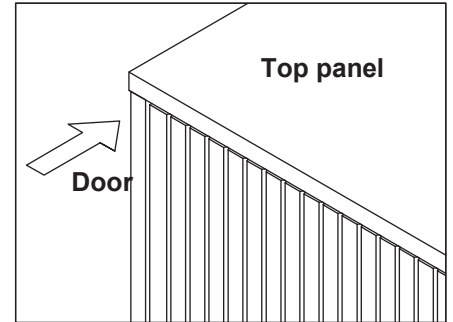

Push the hinge back a little.

## Step 3

Adjust the gap between the door panel and the side panel.

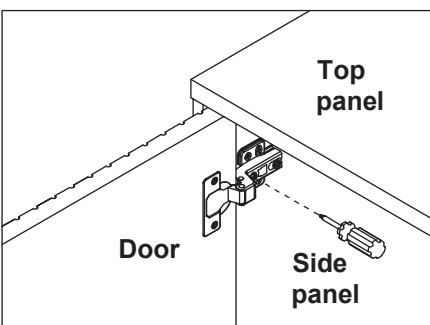

Loosen or tighten the screw indicated a little to adjust the gap between the door panels, adjust the hinge to the right position (see step 3a & 3b).

### Step 3a MOVE DOOR LEFT

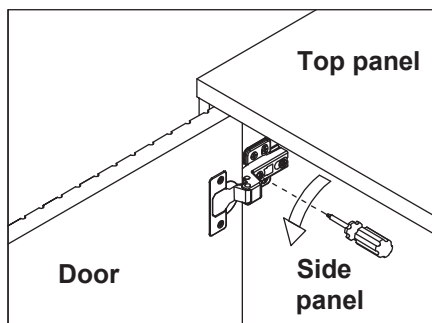
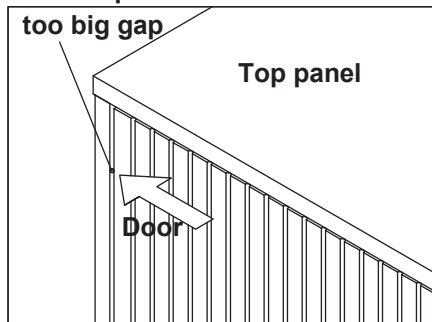

Turn the screw clockwise a little as shown to make the gap smaller

### Step 3b MOVE DOOR RIGHT

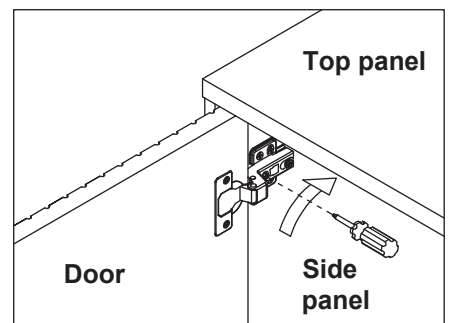
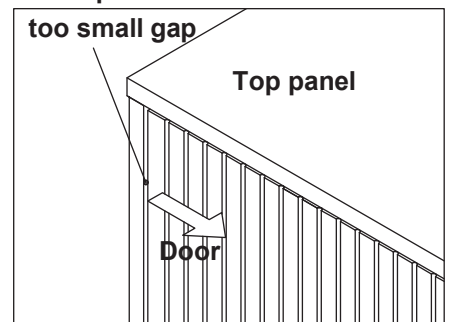

Turn the screw counterclockwise a little as shown to make the gap bigger

**Thank you for your support!**

