

# ASSEMBLY INSTRUCTIONS

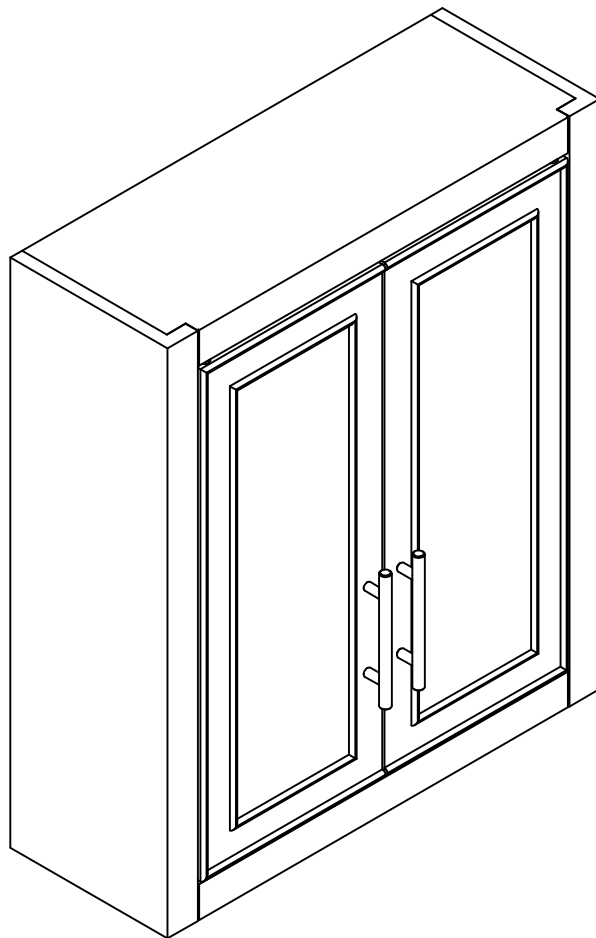

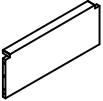

## Wall Cabinet

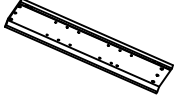
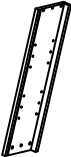
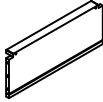
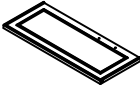
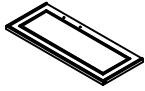
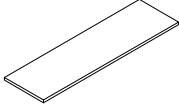
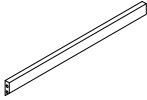
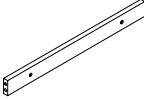
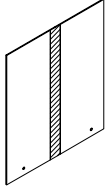
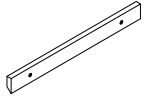

# PART LIST

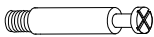
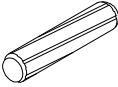
				
<p>Top Panel 1 PC</p>	<p>Left Panel 1 PC</p>	<p>Right Panel 1 PC</p>	<p>Bottom Panel 1 PC</p>	<p>Left door 1 PC</p>
				
<p>Right door 1 PC</p>	<p>Adjustable Shelf 2 PCS</p>	<p>Upper Rail 1 PC</p>	<p>Lower Rail 1 PC</p>	<p>Back Panel 1 PC</p>
				
<p>Support Plate 1 PC</p>				

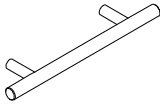
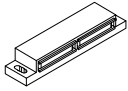
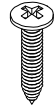
# HARDWARE LIST

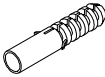
		 <p>Ø8*30mm</p>	 <p>Ø5/32"*16</p>	
<p>Cam Lock 8 PCS</p>	<p>Cam Bolt 8 PCS</p>	<p>Wood Dowel 12 PCS</p>	<p>Round Head Bolt 4 PCS</p>	<p>Handle 2 PCS</p>
	 <p>Ø3*14mm</p>		 <p>Ø3*14mm</p>	
<p>Double Magnet 1 PC</p>	<p>Round Head Screw 2 PCS</p>	<p>Shelf Holder 8 PCS</p>	<p>Long Screw 4 PCS</p>	<p>Wall Anchor 4 PCS</p>

## ADDITIONAL TOOLS (Not Provided)

Note: It is not recommended to use power tools during assembly.

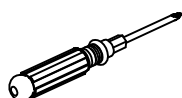

Phillips Head Screwdriver

Note: Wood dowels are intended for alignment. Additional clearance between wood dowel and pre-drilled hole is intentional for ease of assembly.

- \* Required screwdriver & mallet, not included.
- \* Before discarding packing materials, please check to make sure that all parts and hardware is present.
- \* Two people needed for assembly.
- \* Please follow the instructions closely; do not over tighten screws or bolts unless instructed.
- \* After a few days from initial assembly, the product may have acclimated to the new environment. Please retighten the hardware.

## Guideline For Assembling of Cam Lock(A & B)

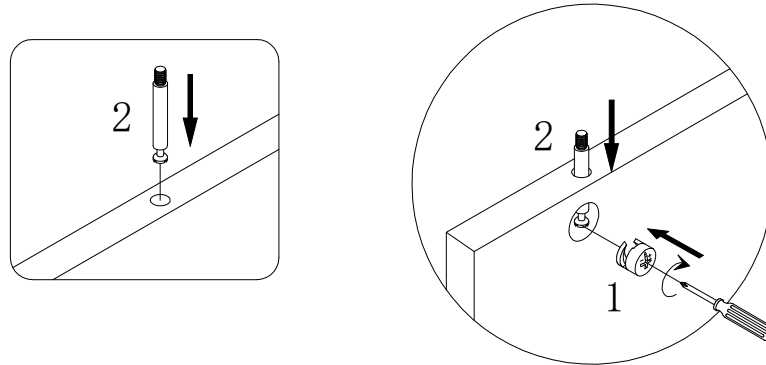

Screw camlock bolt (2) to wood part.  
Do not assemble camlock (1) unless instructed.  
To assemble camlock (B), ensure long side of the + is facing the bolt (2) before inserting into hole.

**Step 1. Attach handles (part #5) to doors (part E & F) using round head bolt (part #4) and phillips head screwdriver.**

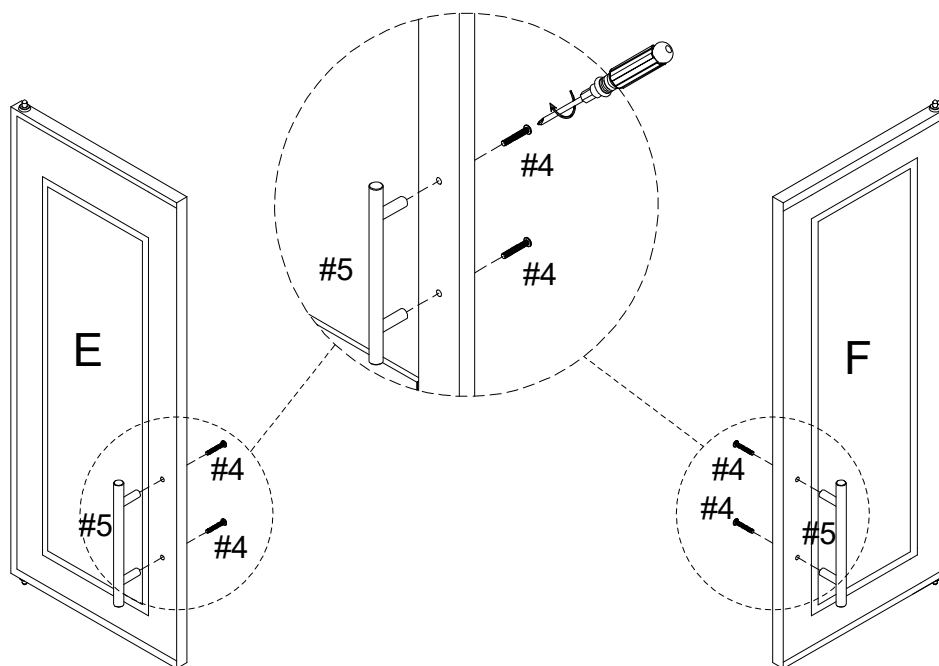



#4  x 4

#5  x 2

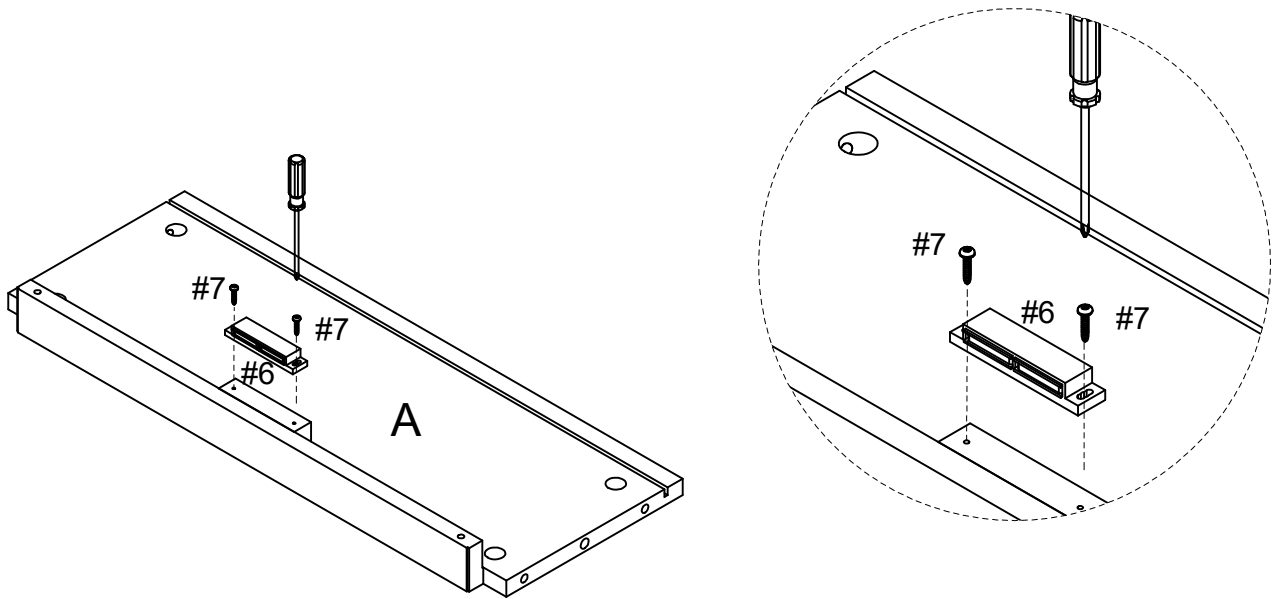

Step 2. Attach double magnet (part #6) to top panel (part A) using round head screws (part #7) and phillips head screwdriver.

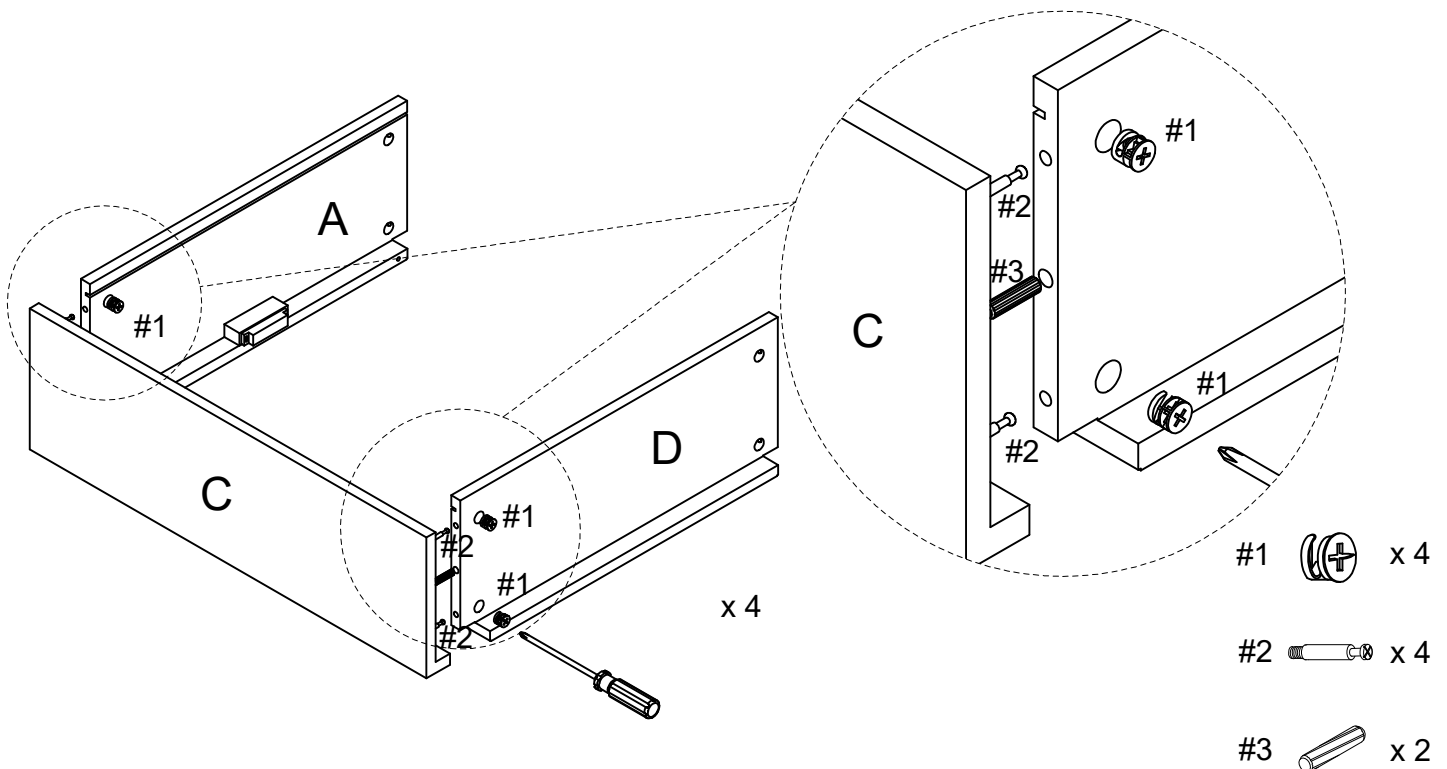

- #6  x 1
- #7  x 2

Step 3. Attach top panels (part A) and bottom panel (part D) to right side panel (part C) using camlock (part #1), cam bolt (part #2), wooden dowels (part #3) and phillips head screwdriver.



- #1  x 4
- #2  x 4
- #3  x 2

Step 4. Attach upper rail (part H) and lower rail (part I) to right side panel (part C) using wooden dowels (part #3).

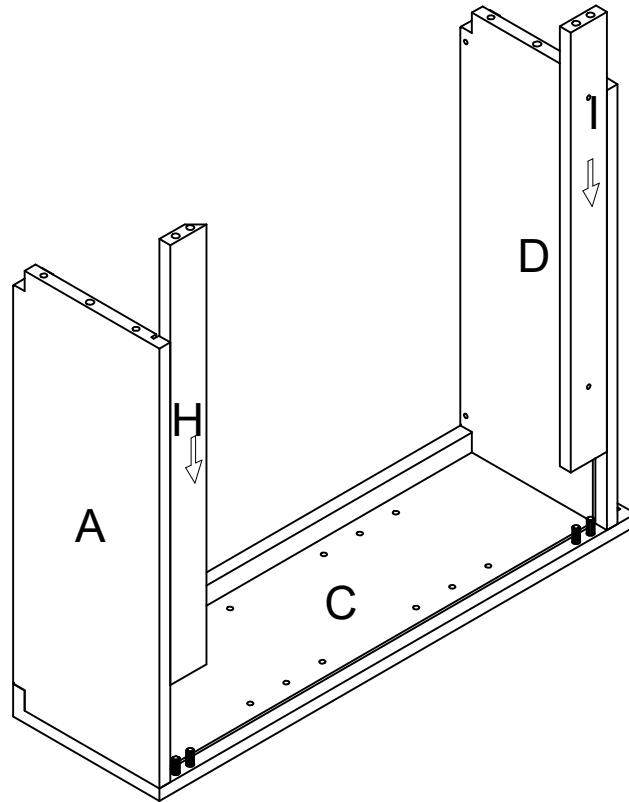

#3  x 4

Step 5. Slide back panel (part J) into the grooves of assembled unit (parts A, B & D).  
Note: Pay attention to the upper rail (part H) must be assembled as show.

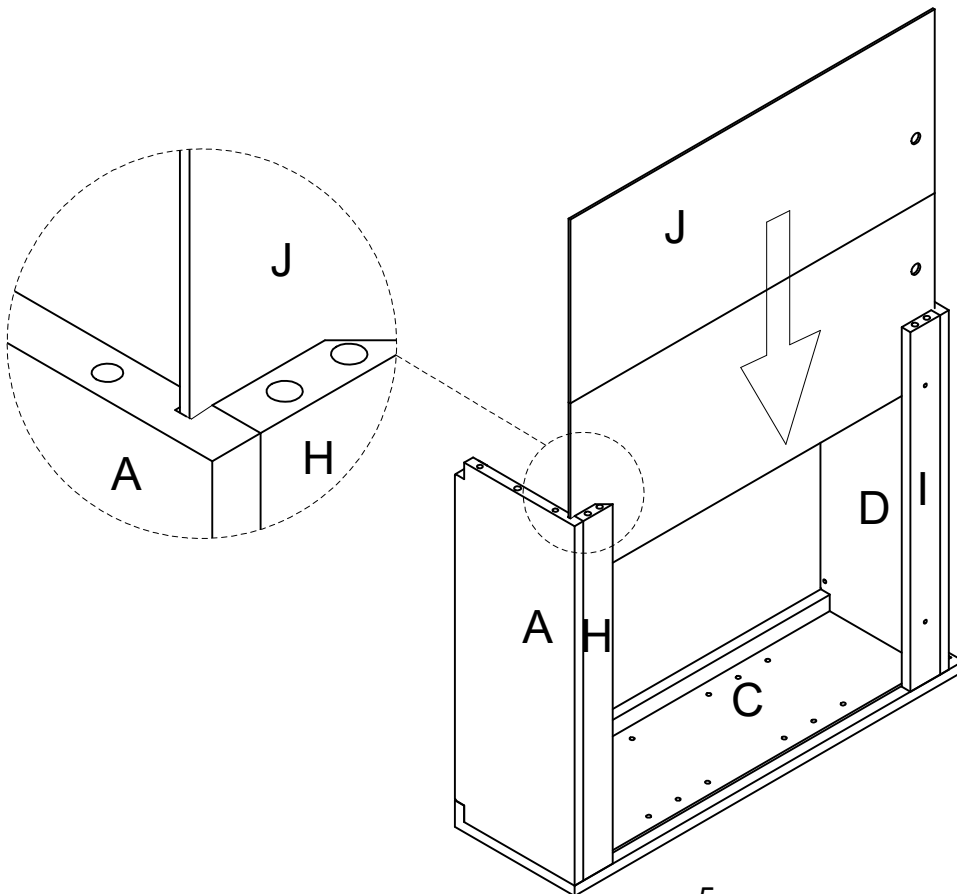

Step 6. Attach left side panel (part B) to assembled unit (parts A, D, H & I) using camlock (part #1), cam bolt (part #2), wooden dowels (part #3) and phillips head screwdriver.

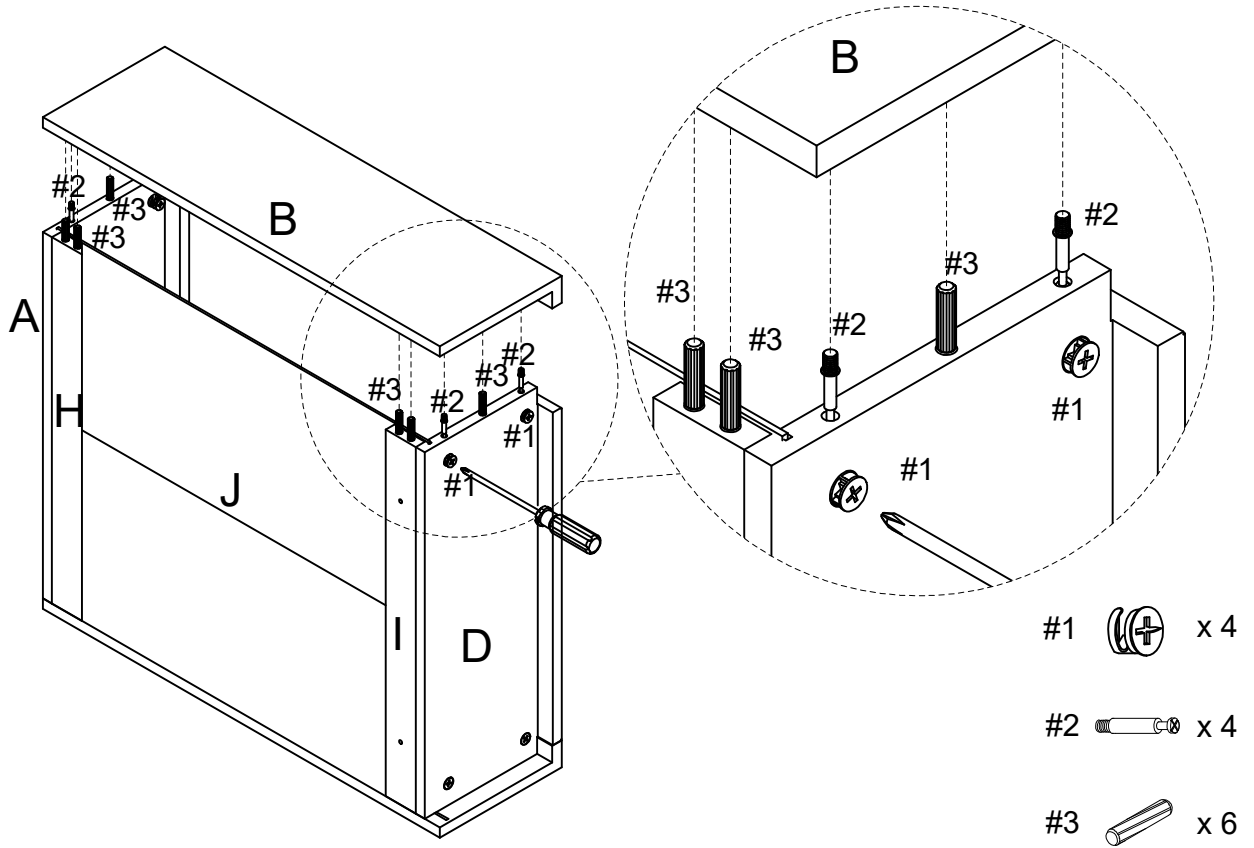

Step 7. Carefully turn the unit upright. Attach doors (parts E & F) by placing bottom pin hinge (pre-installed in door) in the pre-drilled hole of bottom panel (part D), then depress the top spring-loaded pin hinge so it can be placed in the pre-drilled hole of top panel (part A).

Note: Be sure top and bottom pin hinges are fully extended to secure doors in place.

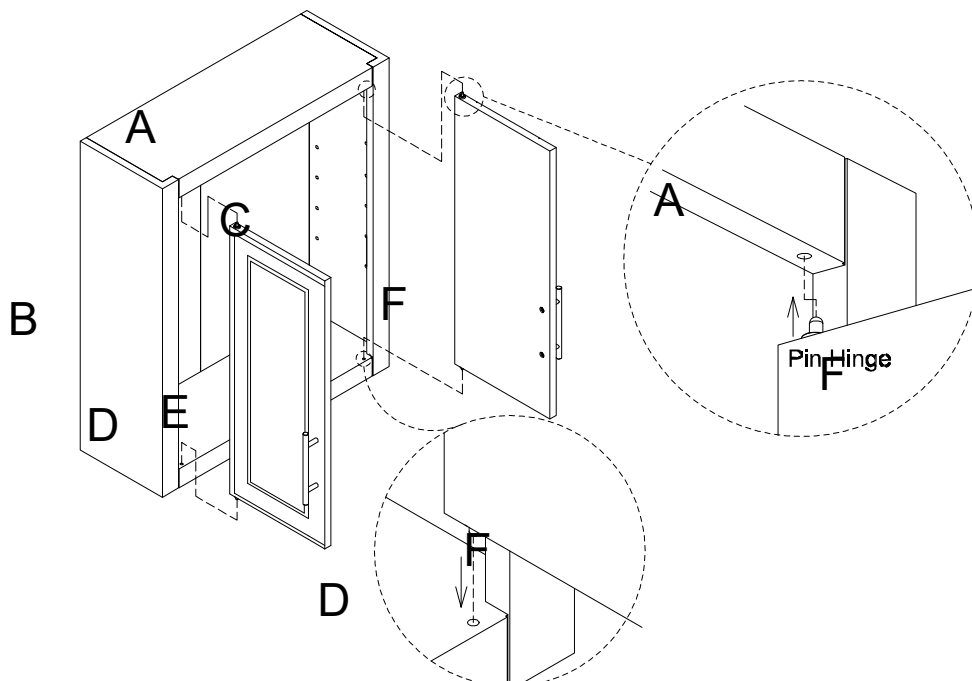

Step 8. Hold support plate (part K) in desired location. Support plate (part K) will be about 2-1/2" lower than the top of assembled unit. Make sure support plate (part K) is level, we recommend using a leveler to ensure it's oriented correctly. Use a pencil to mark the anchor locations using support plate (part K) screw holes as a guide. Drill two 11/32" holes in these marked spots and tap wall anchors (part #10) into the drilled holes. Secure support plate (part K) to wall anchors (part #10) using long screws (part #9) and phillips head screwdriver. Mount assembled unit onto support plate (part K). Upper rail (part H) has a recessed area that will hook onto support plate (part K). Use a pencil to mark the 2nd set of anchor locations using assembled unit screw holes as a guide. Remove assembled unit and drill two 11/32" holes in these marked spots and tap wall anchors (part #10) into the drilled holes. Remount assembled unit and secure it to wall anchors (part #10) using long screws (part #9) and phillips head screwdriver.

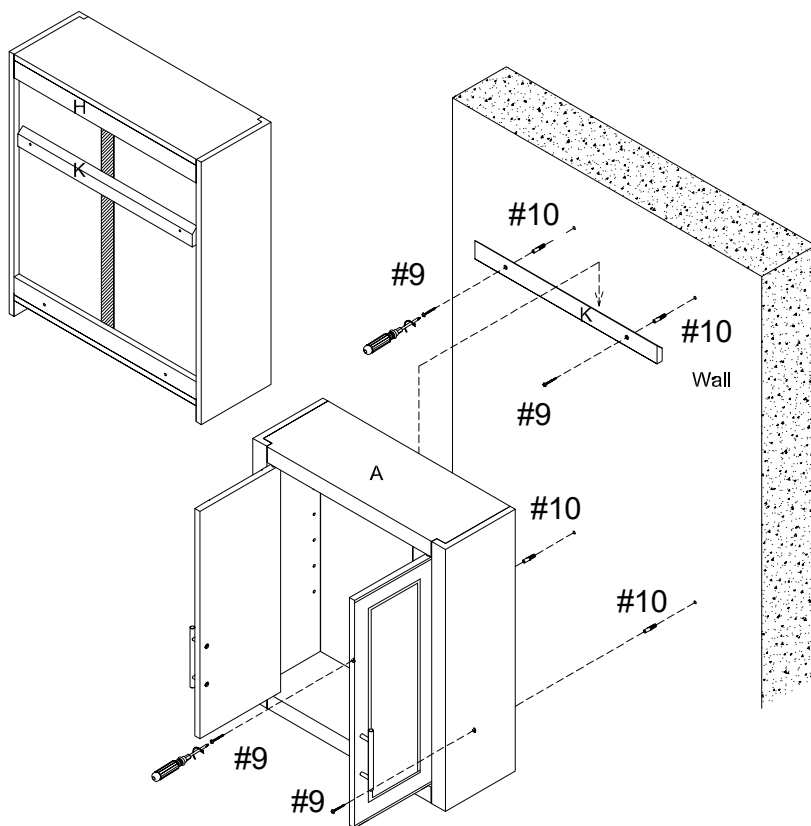

#9  x 4

#10  x 4

Step 9. Place shelf holders (part #5) into desired position and slide adjustable shelves (part G) into place.

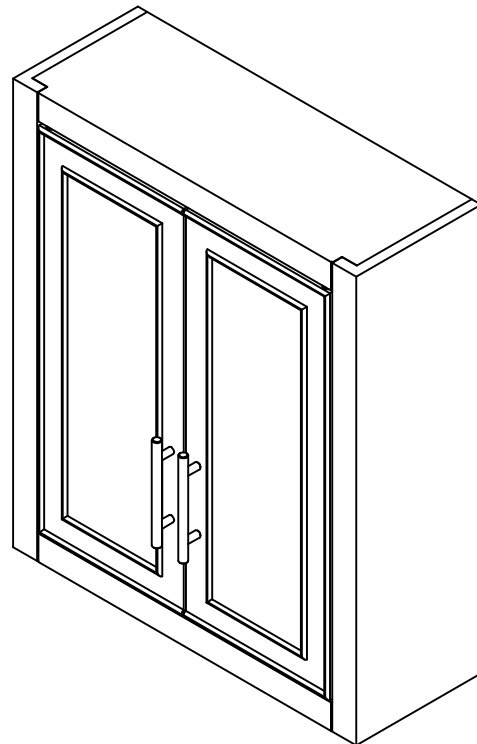
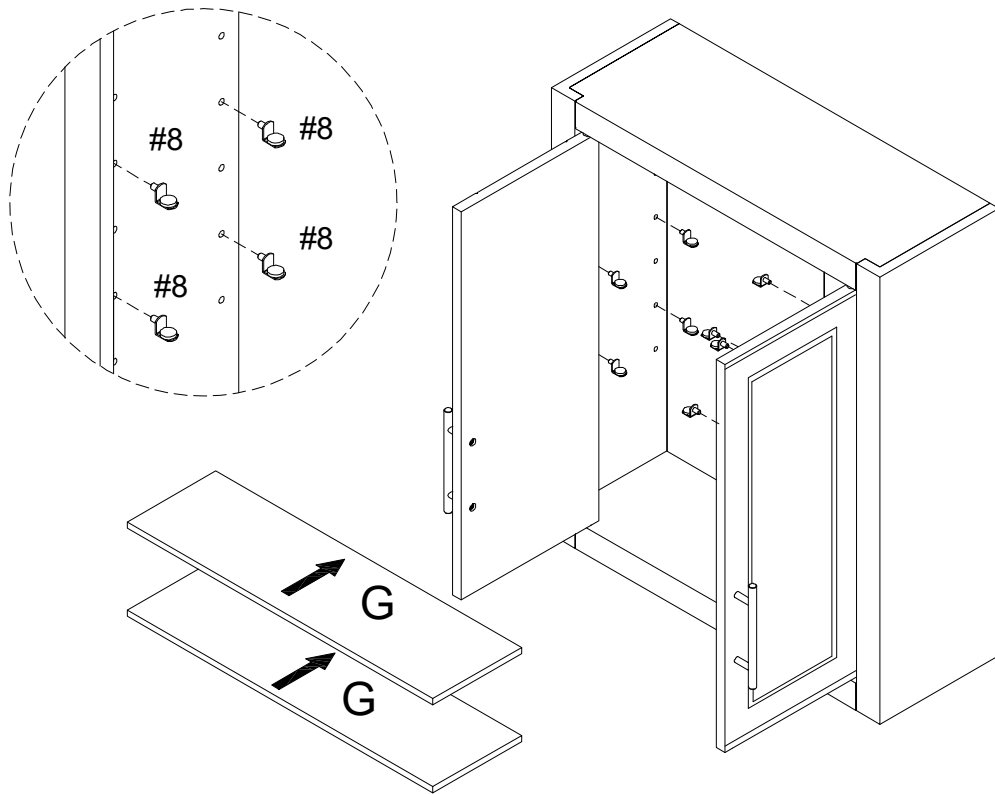

#8  x 8