

## Upholstered bed

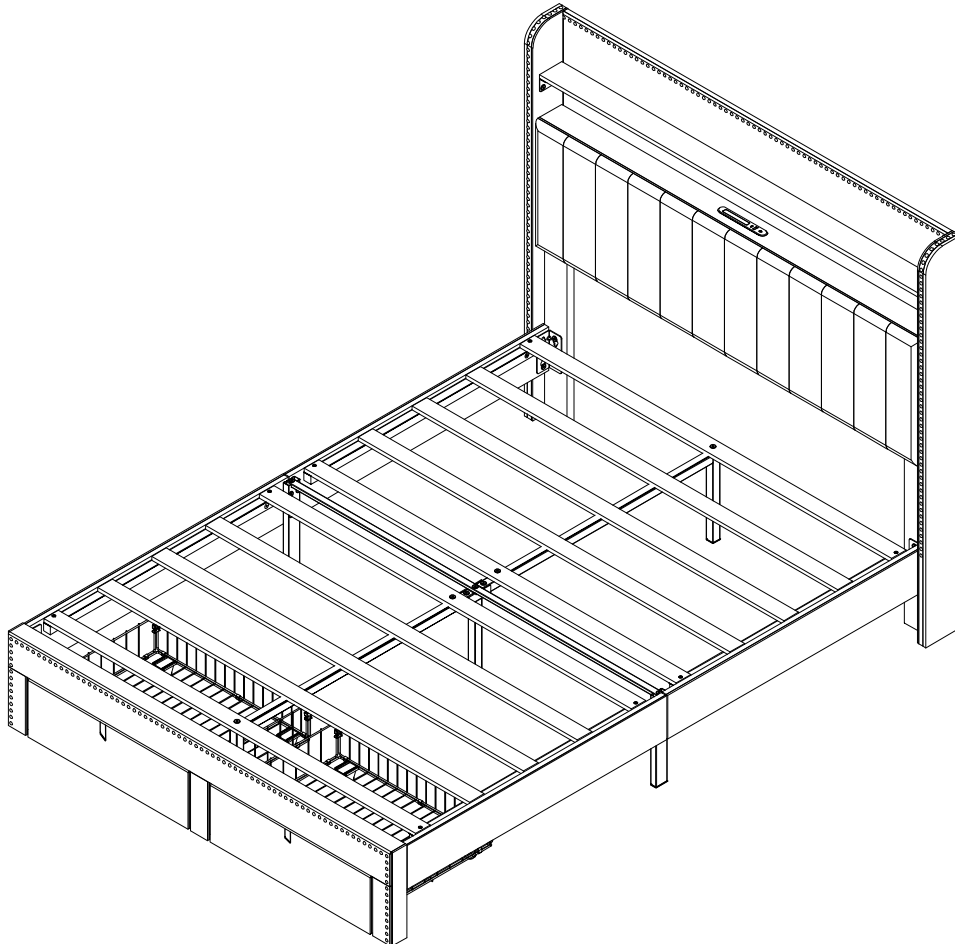

### TIPS

1. Please read the instructions fully before assembly. These instructions include important information which could ensure correct assembly. We have been working on providing high quality products for you. However, in the rare instance that your product is defective, missing parts or there are some issues, please don't hesitate to contact our customer service to submit parts requirements, assembly suggestion, or warranty claims, and we will give the best solution as soon as possible. If necessary, we need you to provide some more clear pictures of the issue.



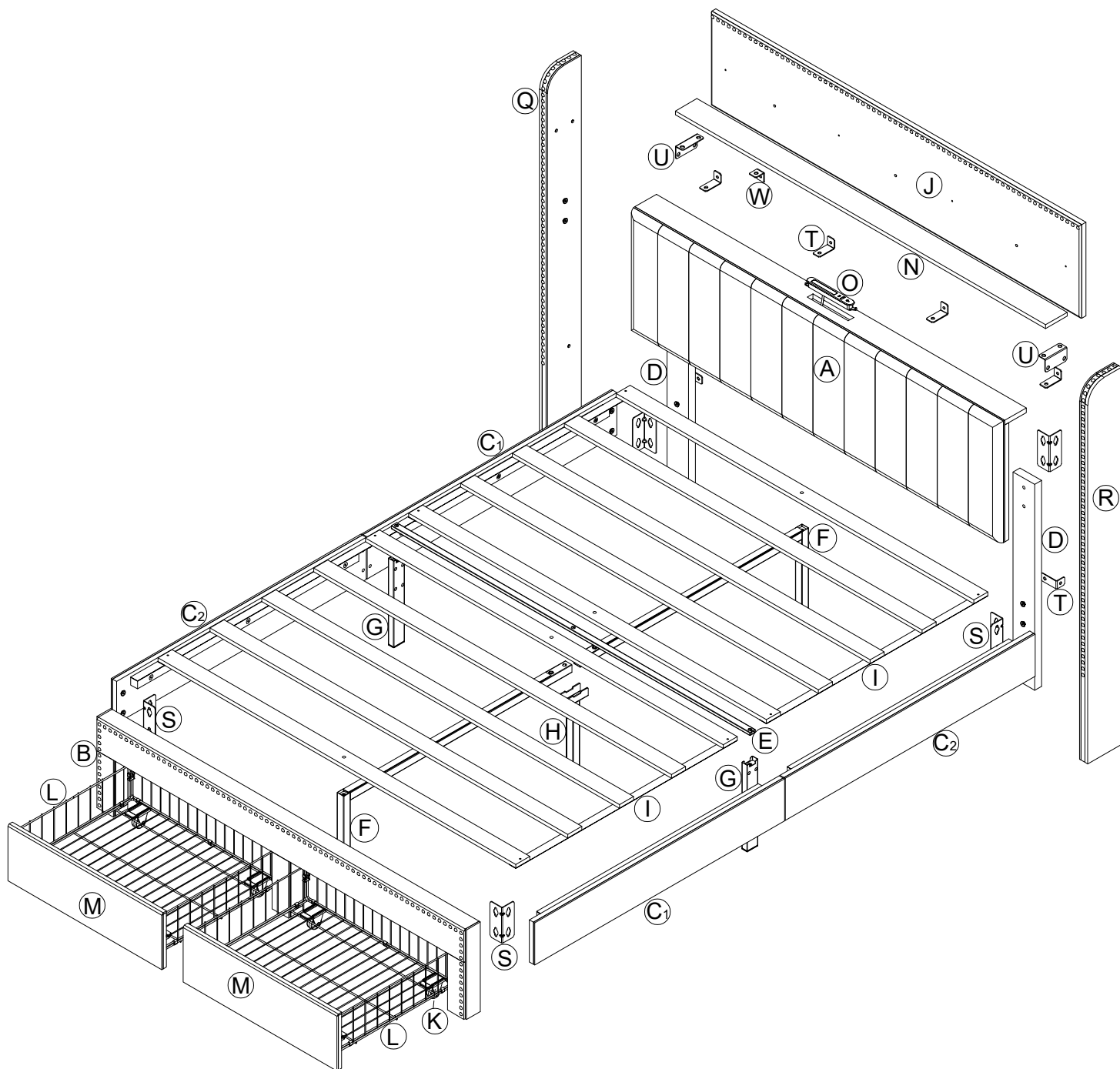

2. Insert the screws in holes and tighten the screws, but not too tight, 70%~80% is ok, finally tighten all the screws. If some issues happened that some screws can not target to the hole or some parts are difficult to install, please adjust the tightness of the screws.

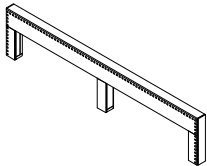

1. This product is not suitable for mattress recessed type.
2. This product is suitable for placing mattresses on the top.

Part List N652P215004

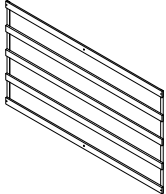
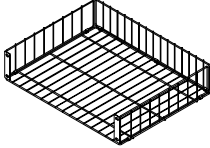
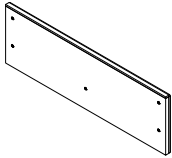
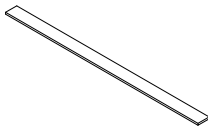
1/2

 <p><b>B</b></p>	 <p><b>D</b></p>	 <p><b>E</b></p>	 <p><b>I</b></p>	 <p><b>L</b></p>
<p>Footboard 1PC</p>	<p>Headboard leg 2PCS</p>	<p>Cross bar 1PC</p>	<p>Slats 2PCS</p>	<p>Drawer frame 2PCS</p>
 <p><b>M</b></p>	 <p><b>N</b></p>	 <p><b>Q</b></p>	 <p><b>R</b></p>	
<p>Drawer panel 2PCS</p>	<p>Bedboard 1PC</p>	<p>Headboard leg 1PC</p>	<p>Headboard leg 1PC</p>	

Part List N652P215006

2/2

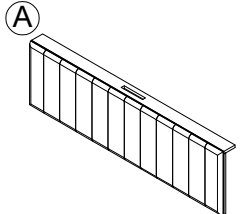
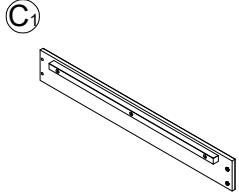
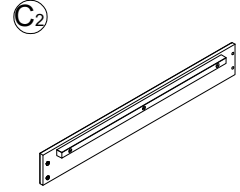
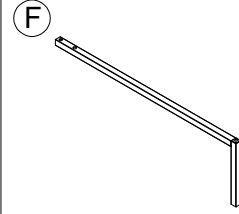
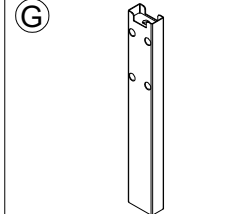
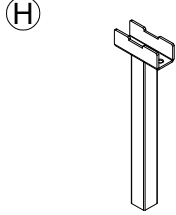
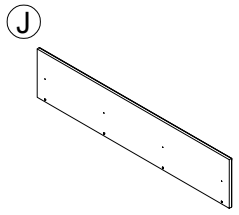
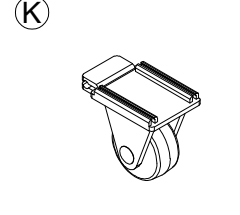
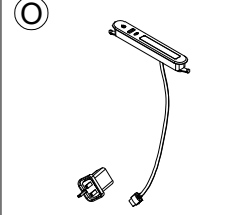
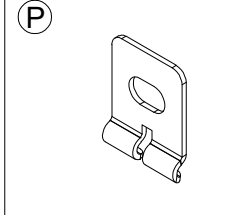
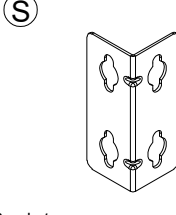
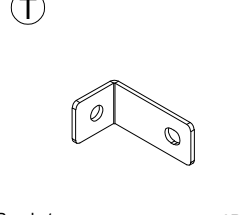
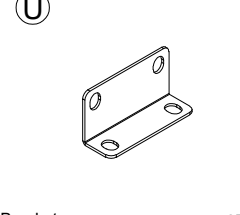
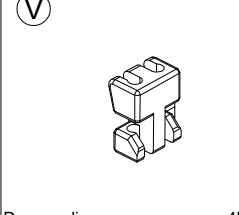
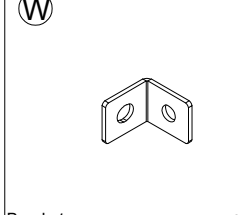
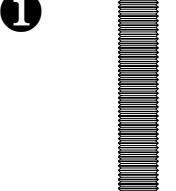
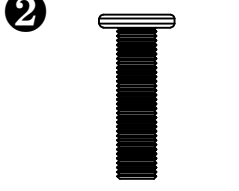
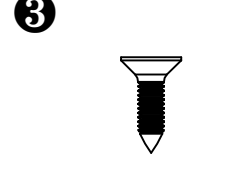
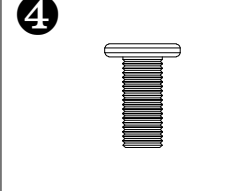
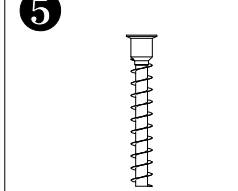
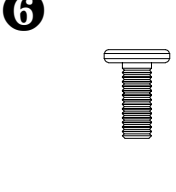
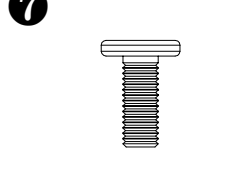
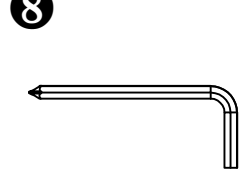
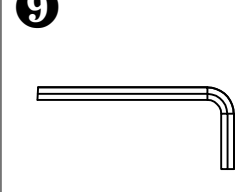
 <p><b>A</b></p>	 <p><b>C1</b></p>	 <p><b>C2</b></p>	 <p><b>F</b></p>	 <p><b>G</b></p>
 <p><b>H</b></p>	 <p><b>J</b></p>	 <p><b>K</b></p>	 <p><b>O</b></p>	 <p><b>P</b></p>
 <p><b>S</b></p>	 <p><b>T</b></p>	 <p><b>U</b></p>	 <p><b>V</b></p>	 <p><b>W</b></p>
 <p><b>1</b></p>	 <p><b>2</b></p>	 <p><b>3</b></p>	 <p><b>4</b></p>	 <p><b>5</b></p>
 <p><b>6</b></p>	 <p><b>7</b></p>	 <p><b>8</b></p>	 <p><b>9</b></p>	

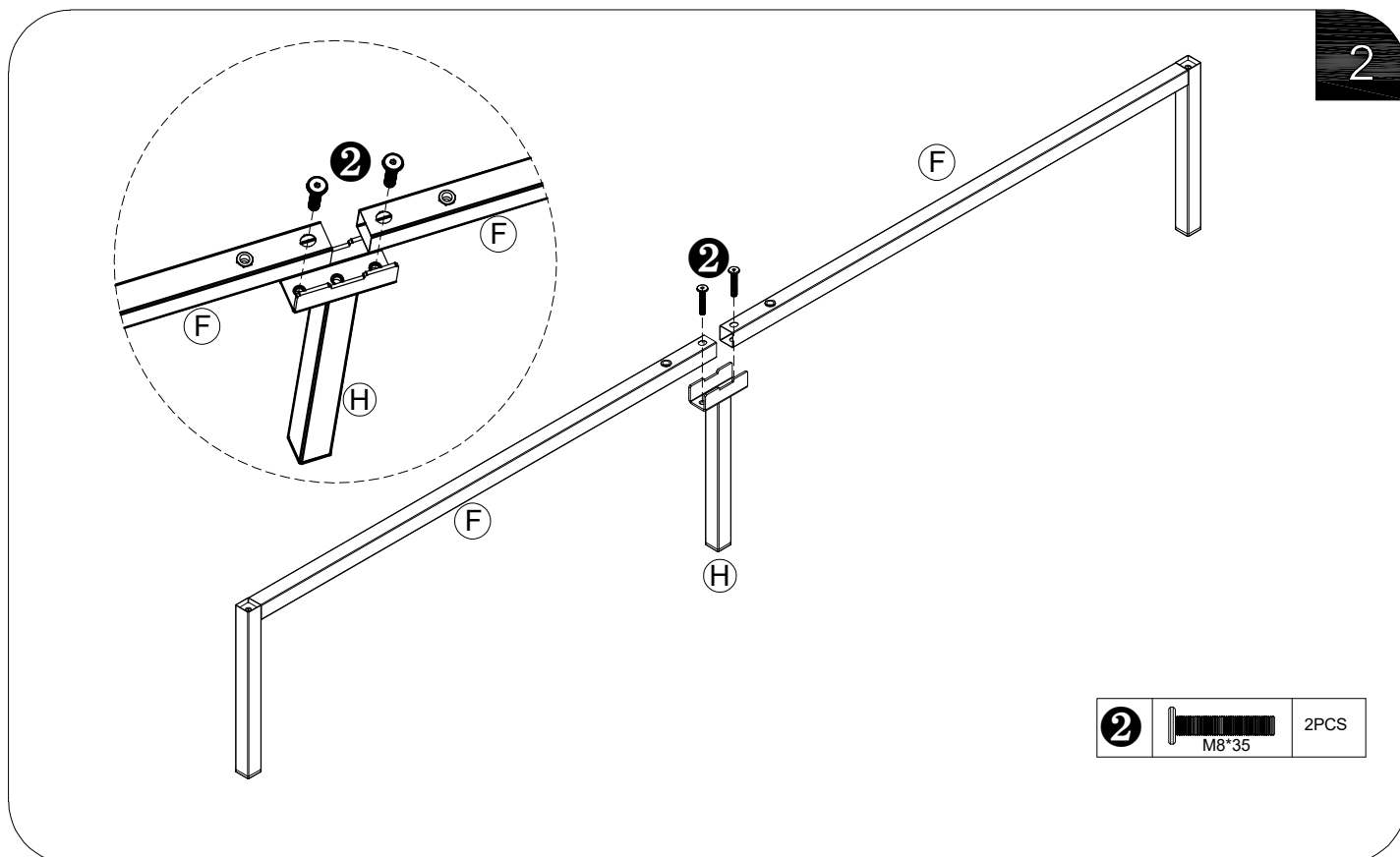
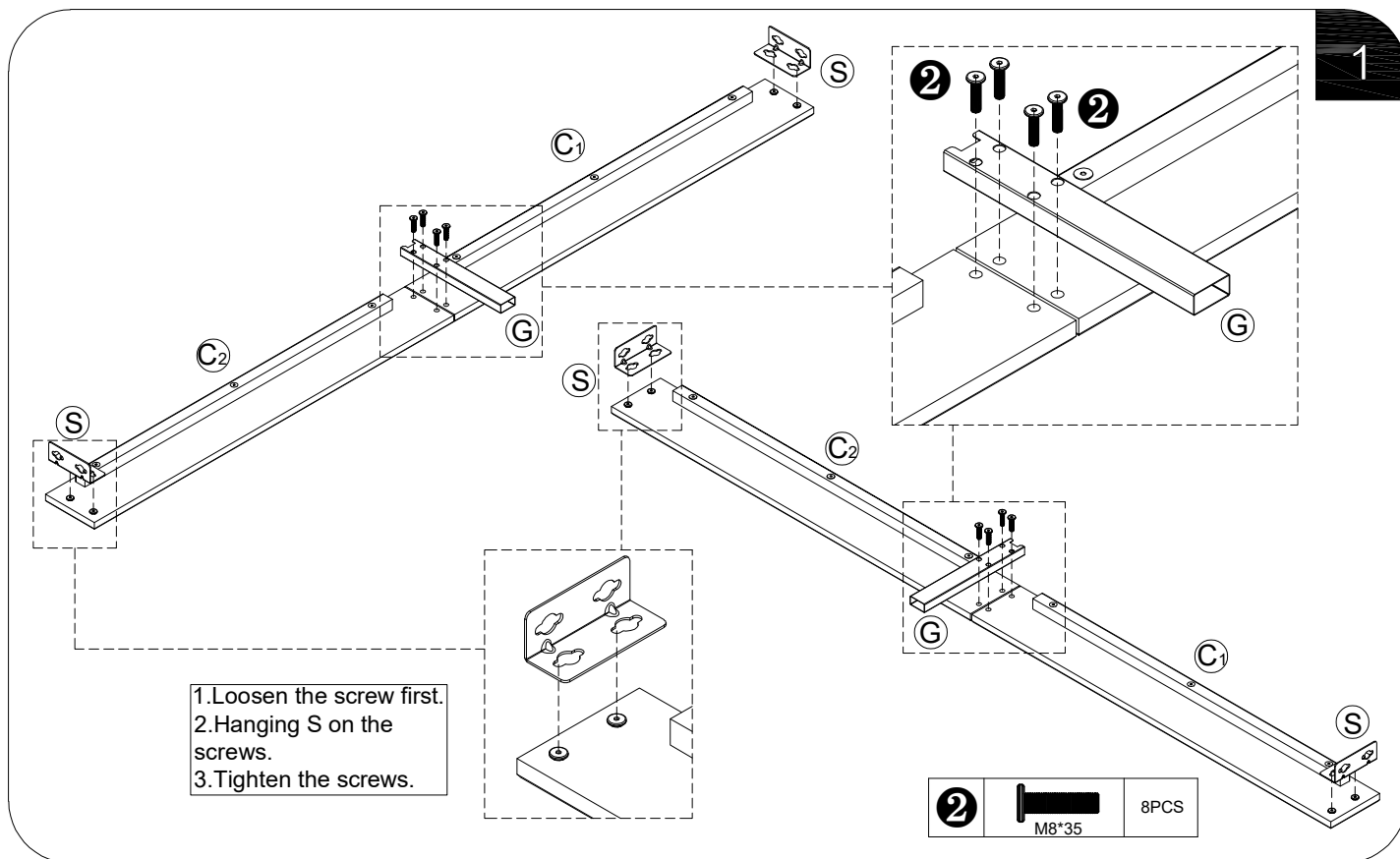

3

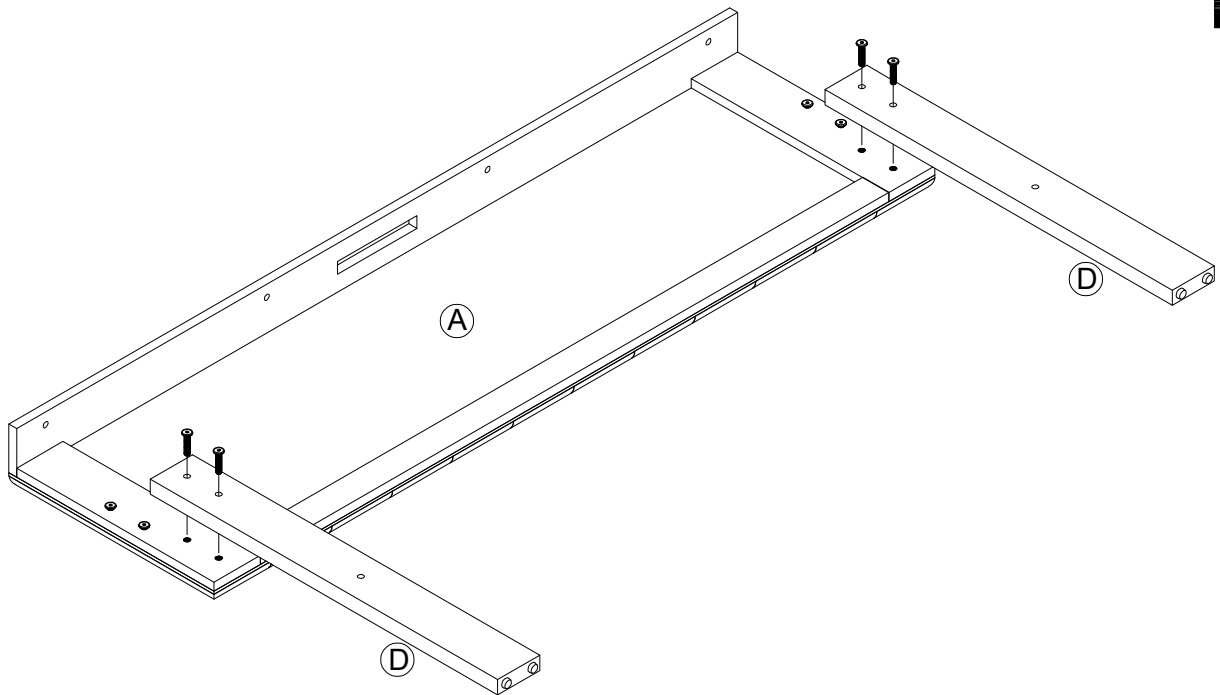

4

1. Loosen the screw first.
2. Hanging S on the screws.
3. Tighten the screws.

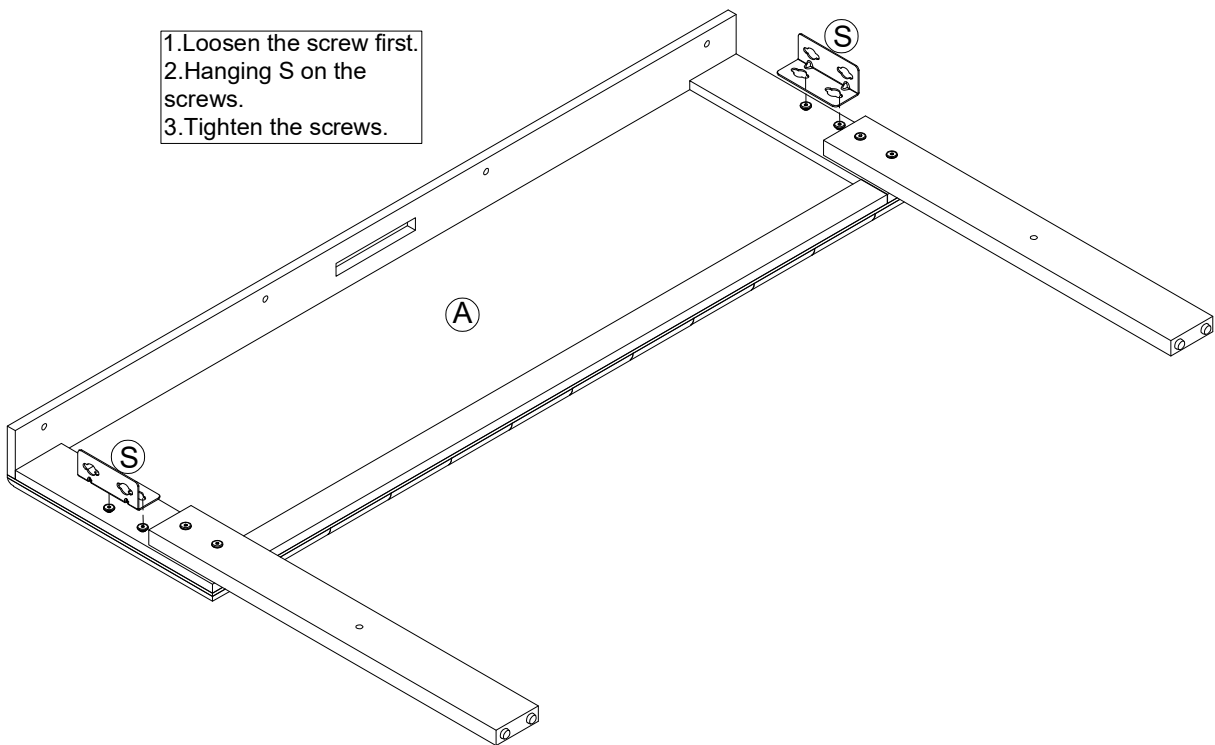

5

1. Loosen the screw first.
2. Hanging S on the screws.
3. Tighten the screws.

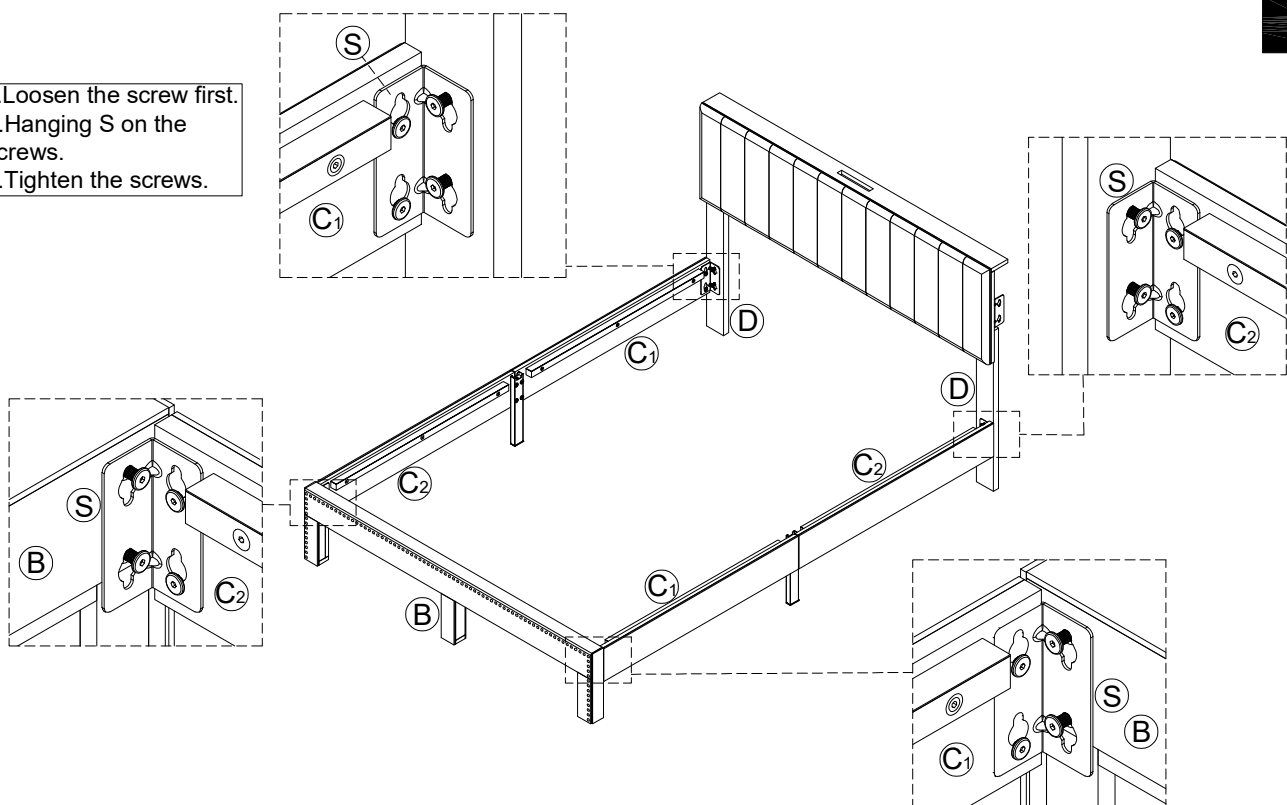

6

1. Loosen the screw first.
2. Hanging S on the screws.
3. Tighten the screws.

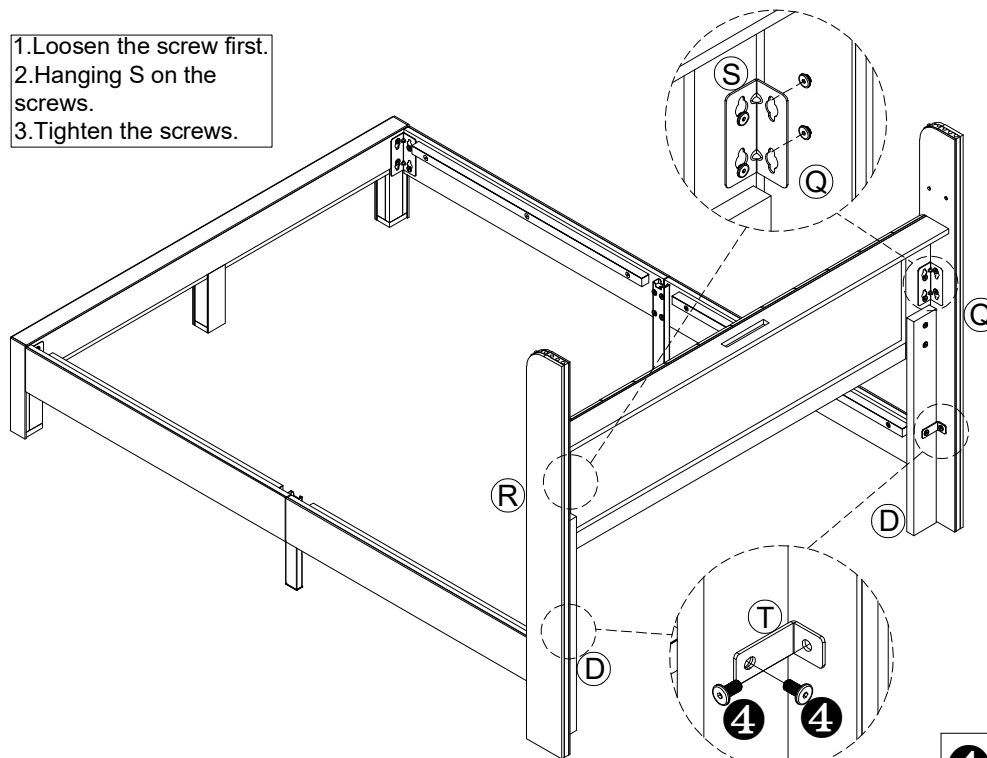

<b>4</b>		4PCS
	M8*18	

7

Unscrew the plastic clip under the socket and put it into the headboard slot.

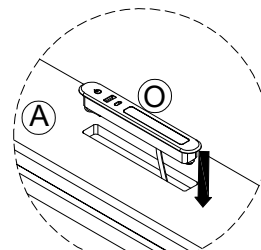
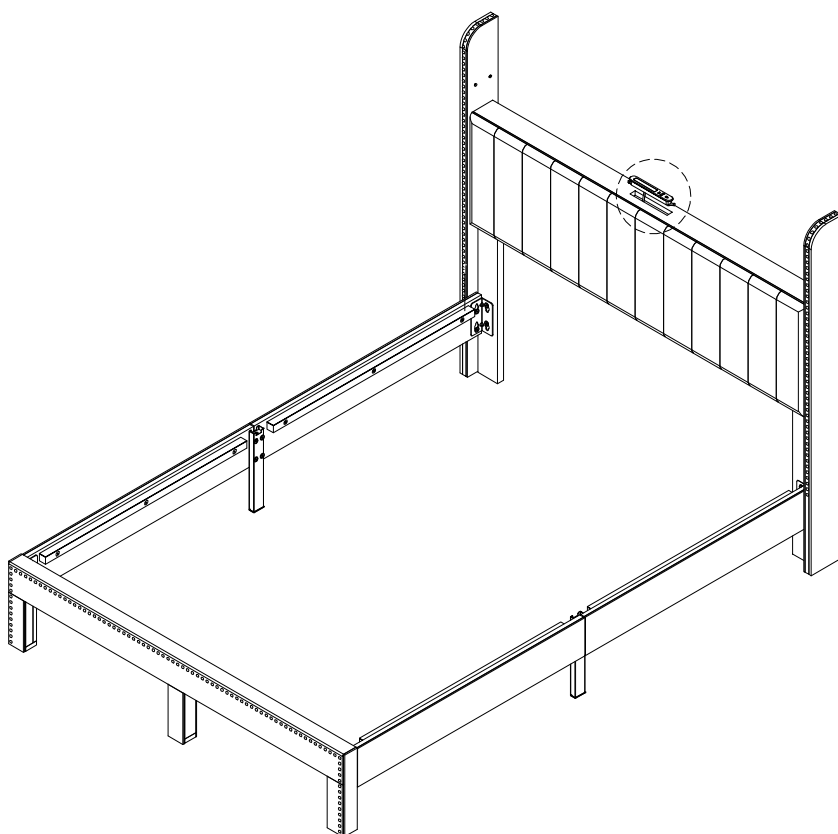

Step 1

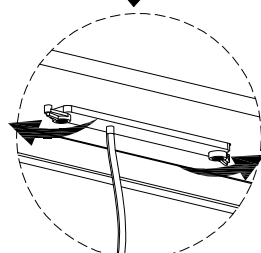

Step 2

Tighten the plastic buckle to secure the socket to the headboard.

8

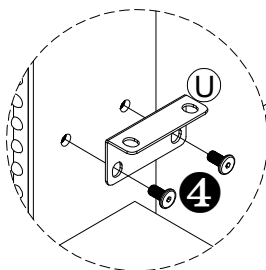
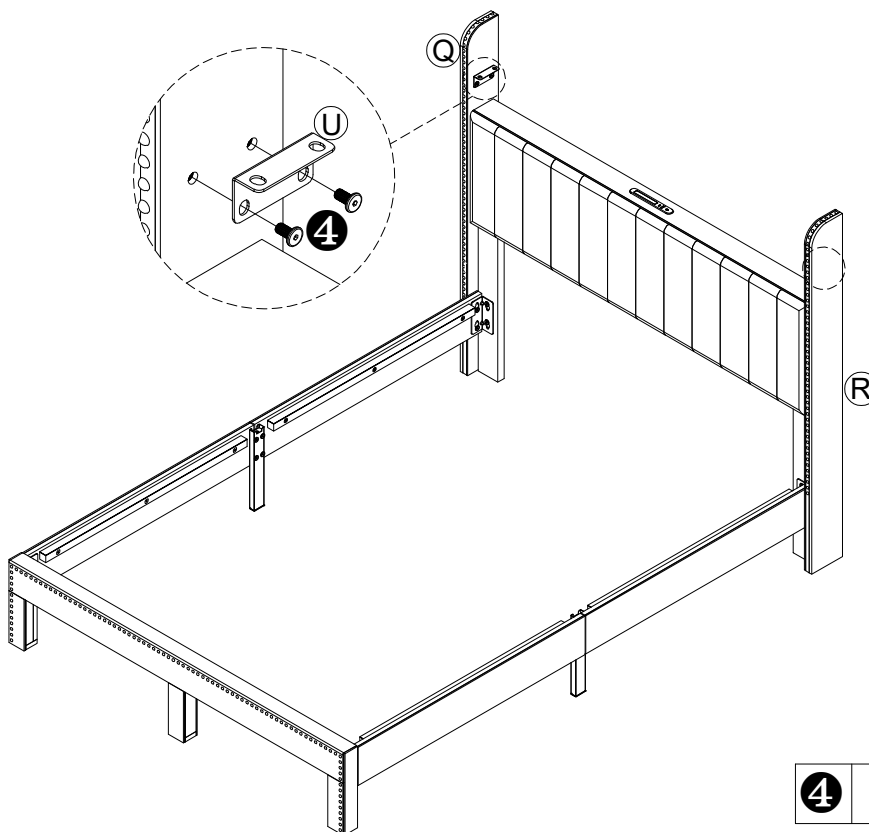

4	 M8*18	4PCS
---	---	------

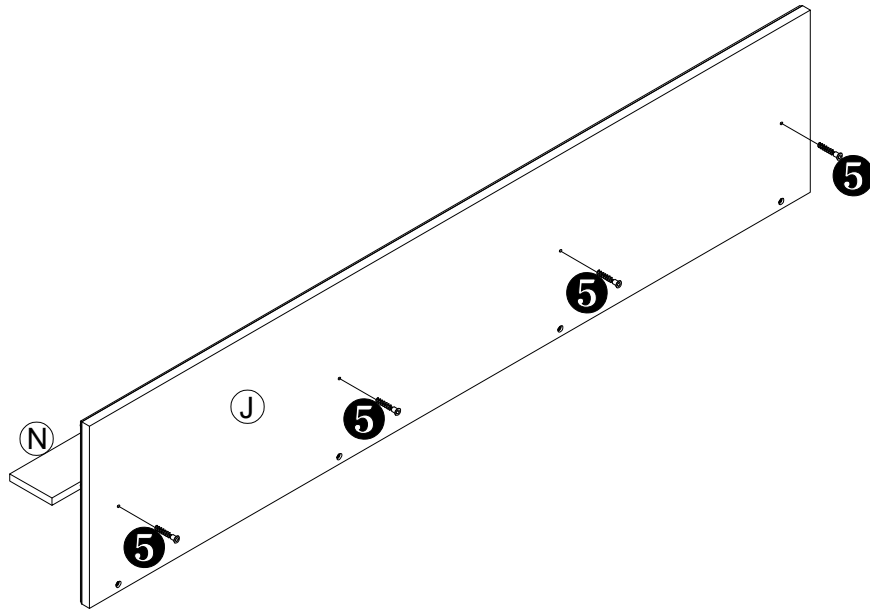

9

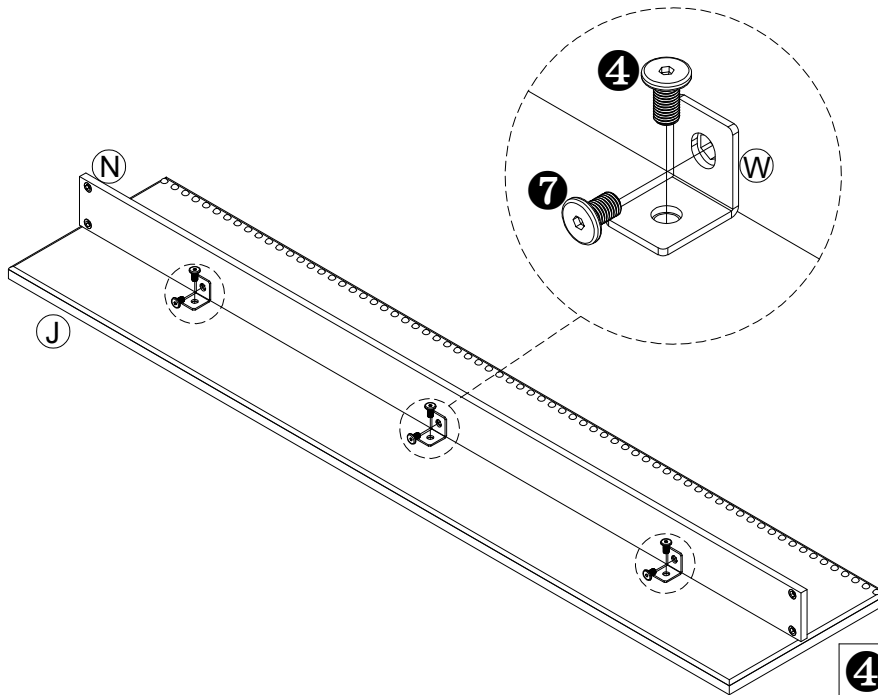

<b>5</b>		4PCS
	M5*30	

10



<b>4</b>		3PCS
	M8*18	
<b>7</b>		3PCS
	M8*12	

11

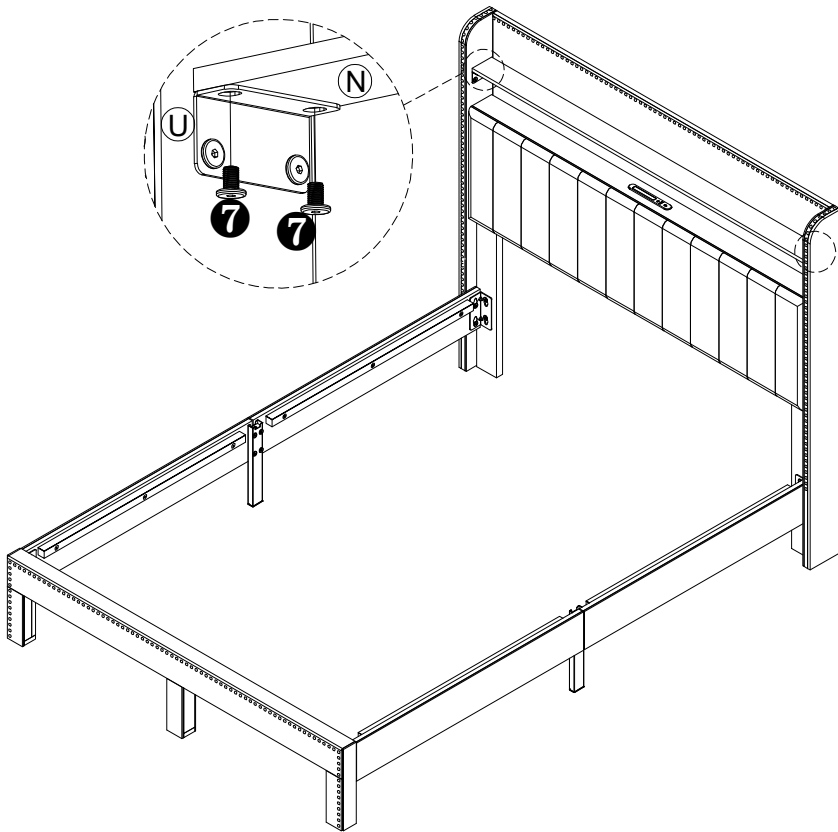

<b>7</b>		4PCS
	M8*12	

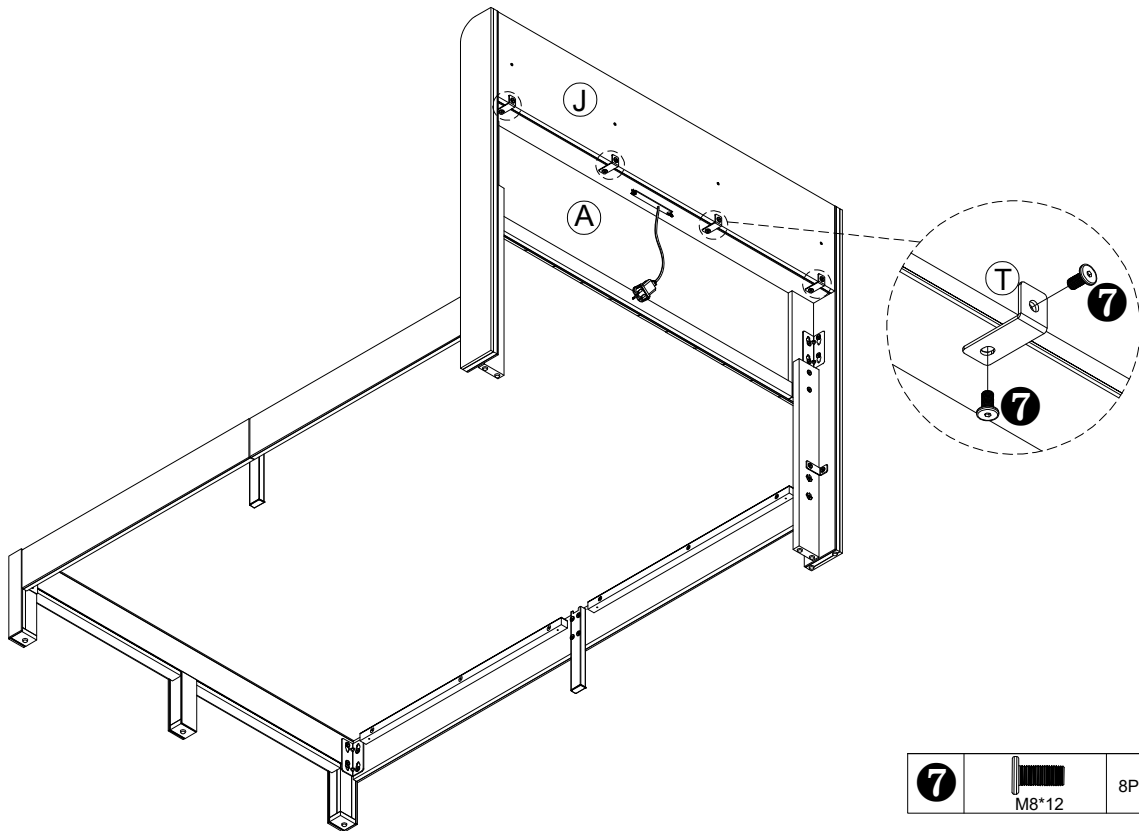

12



<b>7</b>		8PCS
	M8*12	

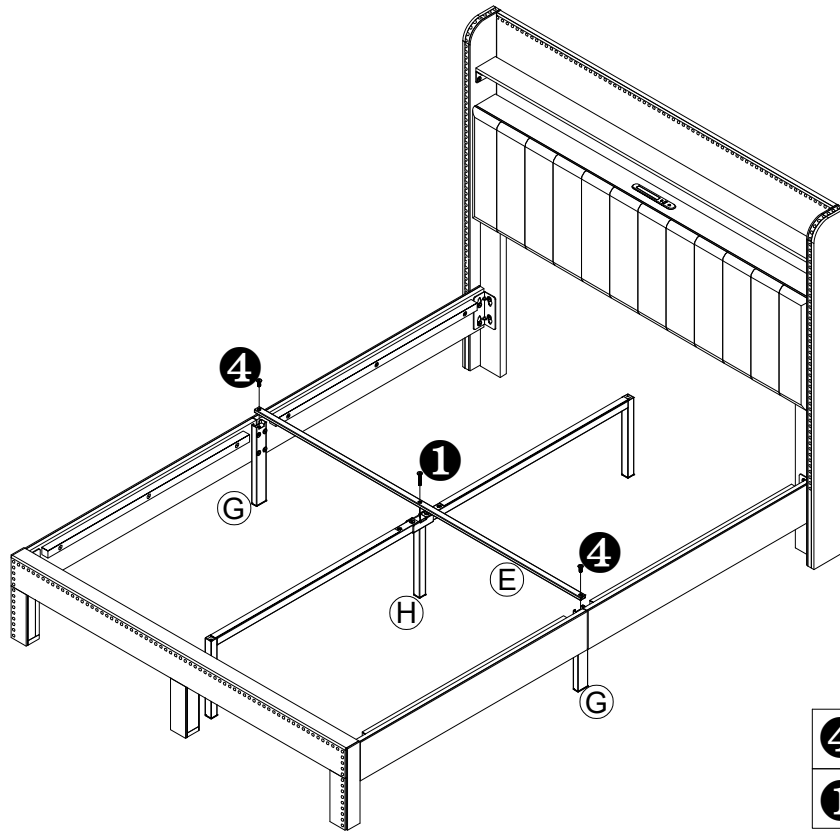

13

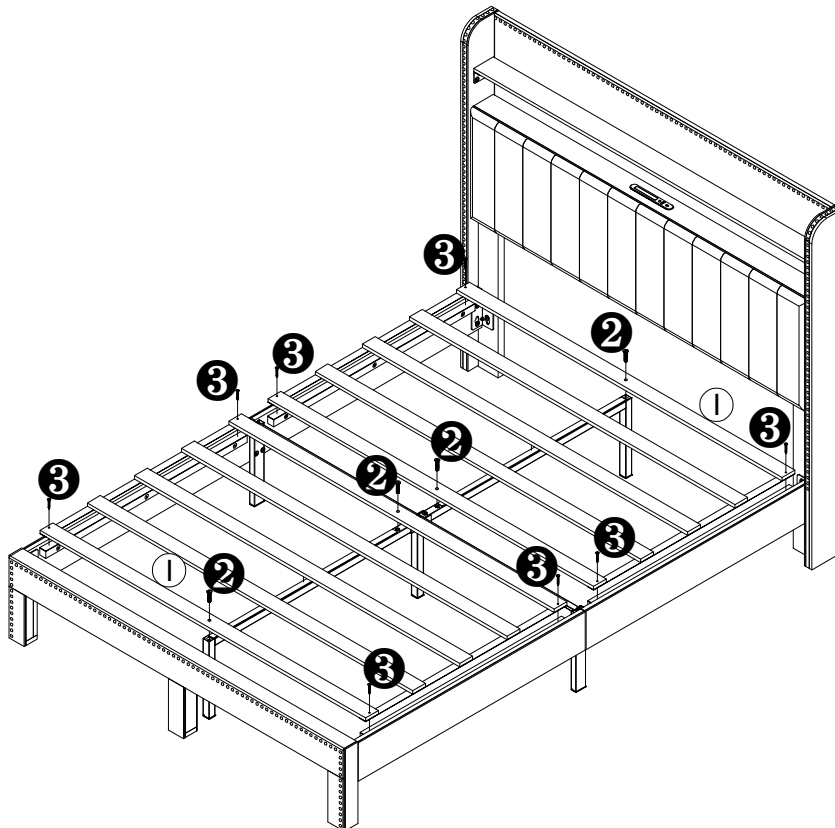

<b>4</b>	 M8*18	2PCS
<b>1</b>	 M8*40	1PC

14



<b>2</b>	 M8*35	4PCS
<b>3</b>	 M5*35	8PCS

15

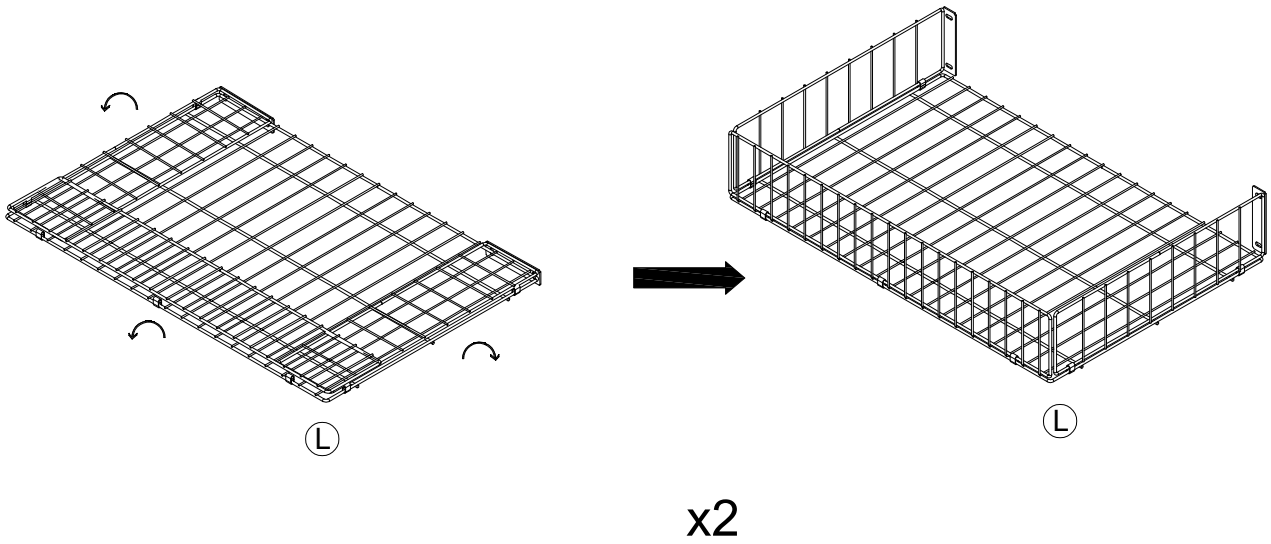

16

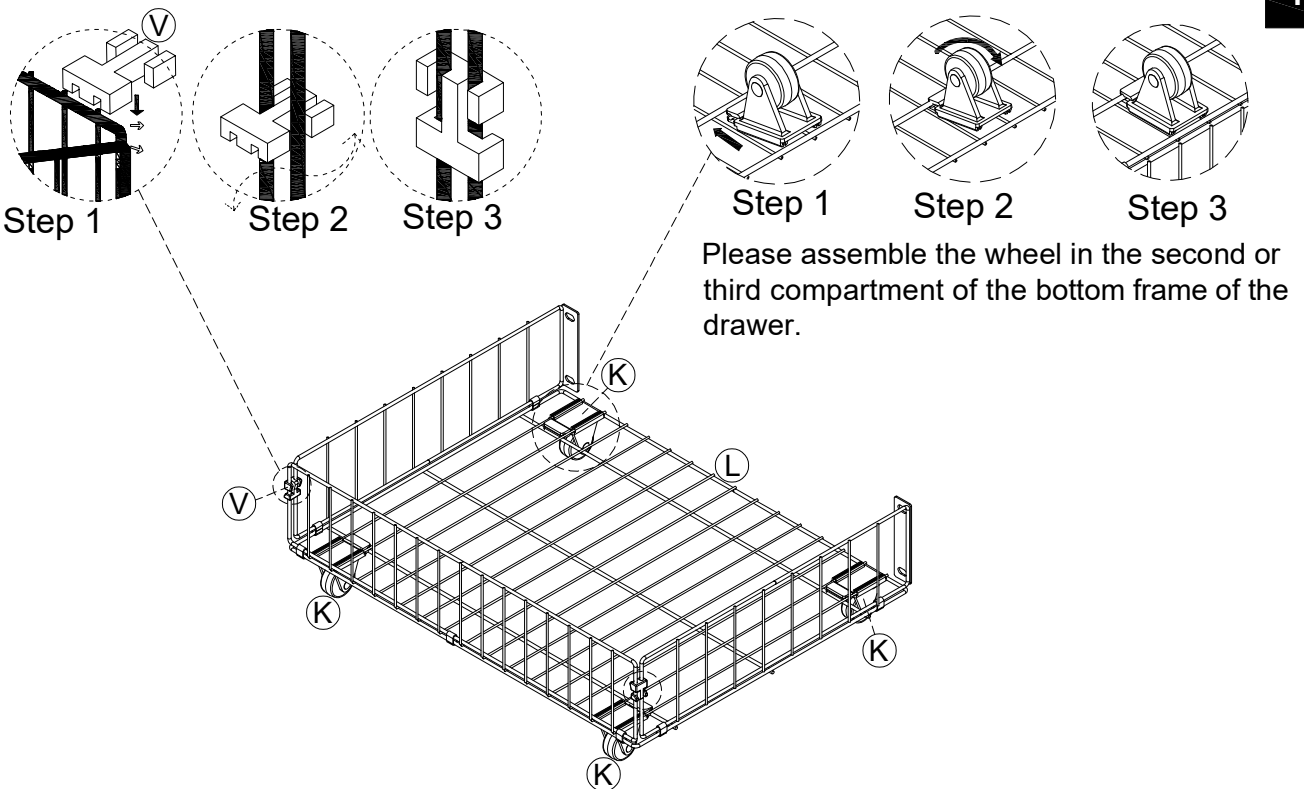

17

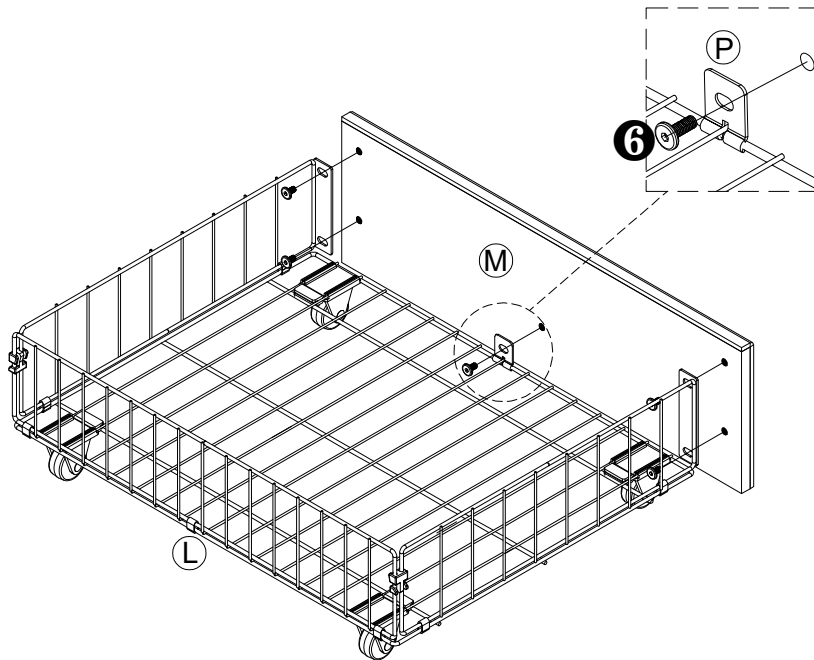

<b>6</b>		10PCS
	M6*10	

18

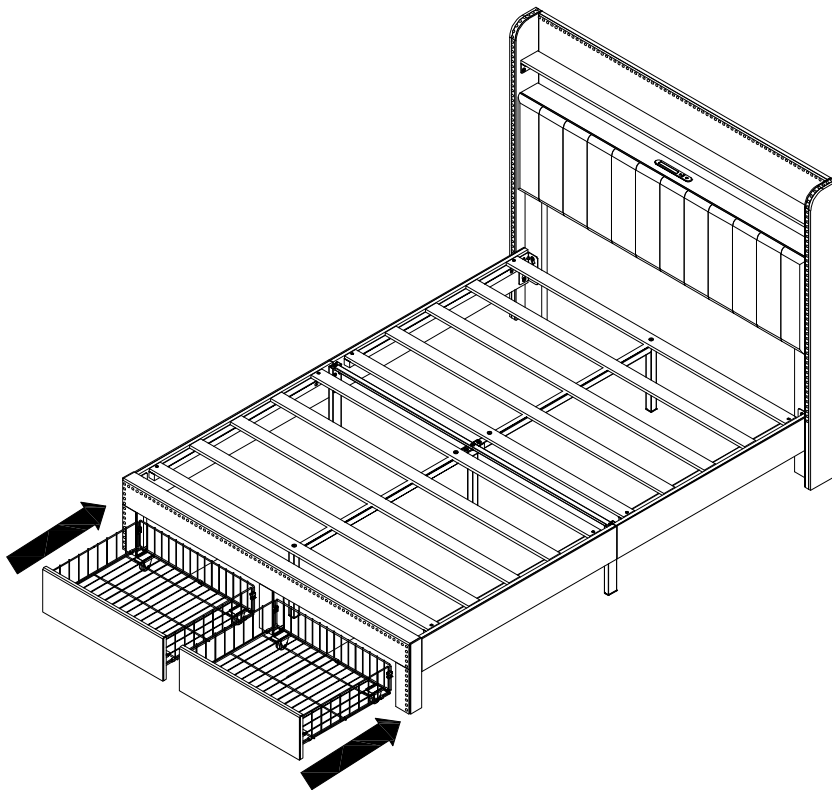

Finish

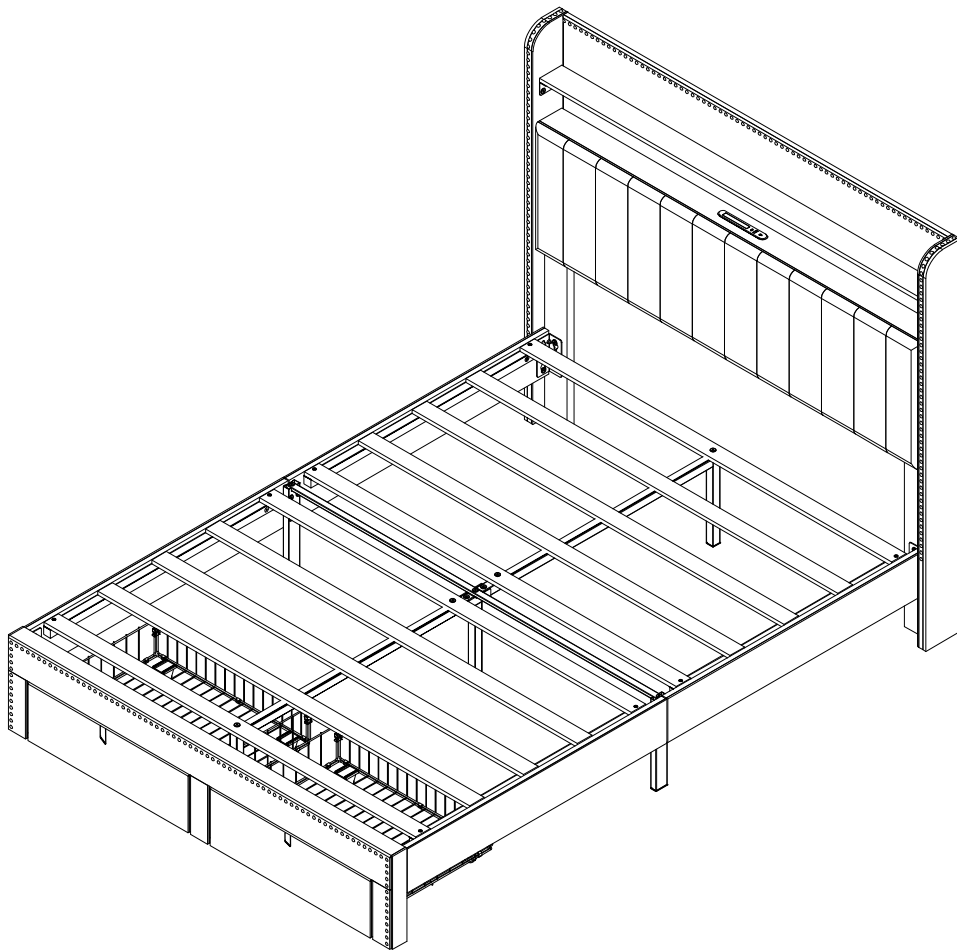

# Certificate of Compliance

**Applicant:** Foshan Xinwang Intelligent Technology Co., Ltd.  
**Address:** Room 2418, fourth floor, Block 3, No. 201, Xingui Road, Shabian village committee, Lecong Zhen, Shunde District, Foshan City, Guangdong province  
**Manufacturer:** Foshan Xinwang Intelligent Technology Co., Ltd.  
**Address:** Room 2418, fourth floor, Block 3, No. 201, Xingui Road, Shabian village committee, Lecong Zhen, Shunde District, Foshan City, Guangdong province  
**Product:** Bedside touch lamp  
**Brand:** /  
**Model No.:** XWD-T012

**Test Standards:**

EN IEC 55015:2019+A11:2020; EN IEC 61000-3-2:2019+A1:2021;  
 EN 61000-3-3:2013+A1:2019+A2:2021; EN 61547:2009

**Report No.:** WJT230919-EMC-B-01

The above product has been tested by us with the listed standards and found in compliance with the technical requirements the council EMC directive 2014/30/EU.

It is possible to use CE mark to demonstrate the conformity with the law.

After preparation of the necessary technical documentation as well as the conformity declaration, the CE marking as shown below can be affixed on the equipment.

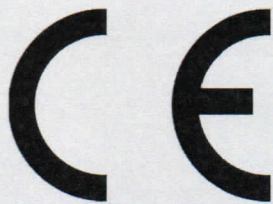

The statement is based on a single evaluation of the sample of above mentioned products. It does not imply an assessment of the whole production.