

Assembly Instructions

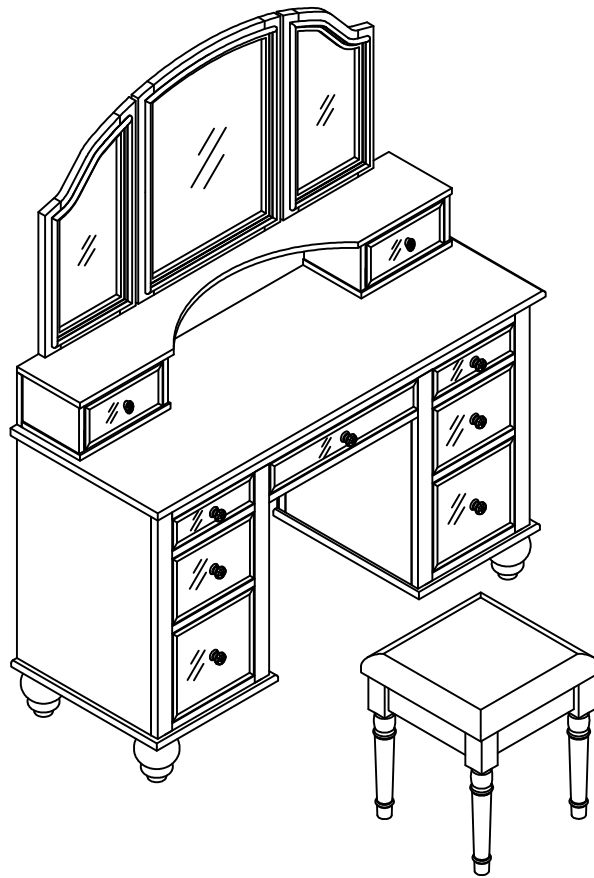

ASSEMBLY RATING

The Assembly Rating is a 5-point system that shows the degree of effort needed in assembling a specific product (with 1 being easy and 5 being difficult). For some products, two persons are recommended.

EASY  DIFFICULT

Tools Required For Assembly:

Allen Wrench

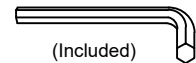

(Included)



2 PERSONS RECOMMENDED

ASSEMBLY & CARE ADVICE

FOR YOUR FURNITURE TO LAST, CORRECT ASSEMBLY AND PROPER MAINTENANCE ARE NECESSARY. PLEASE FOLLOW THE INFORMATION PROVIDED BELOW TO FULLY ENJOY YOUR FURNITURE.

BASIC ASSEMBLY TECHNIQUES



When lock or spring washer is used in an assembly, please make sure the lock or spring washer is placed between the larger flat washer and the head of the screw or bolt.



Position each part correctly and insert screws or bolts into their respective holes by hand tighten or using the proper hand tool. Only tighten when step is completed or when instructed to do so.



Use cardboard or carpet area when assembling furniture to prevent scratches. Make sure the furniture rests on a flat and level surface with each leg evenly touching the floor.



Some furniture comes with height adjustment knobs underneath each leg. To lower or to raise each leg, you need to turn clockwise or counterclockwise, respectively.



Make sure all parts are properly aligned, then use the appropriate hand tool to completely tighten the bolts or screws. Do not use power tools and do not overtighten.



Save the instructions and store the Allen wrench or any supplied tool for later maintenance. After two weeks, check and tighten any loose hardware and repeat again every six months thereafter.

IT IS THE USER'S RESPONSIBILITY TO MAINTAIN THE FURNITURE. THE HARDWARE MAY LOOSEN OVER TIME AND MAY CAUSE THE FURNITURE TO BE WOBBLY AND UNABLE TO SUPPORT ITS INTENDED WEIGHT CAPACITY. THIS MAY LEAD TO COLLAPSE AND MAY CAUSE SERIOUS INJURY.

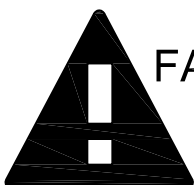

FAILURE TO FOLLOW THE GUIDELINES ABOVE MAY RESULT IN INJURY AND/OR PROPERTY DAMAGE.











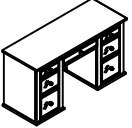
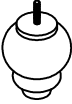
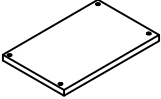
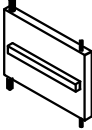
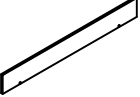

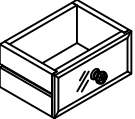



Before you begin, please read Page 2 of "Assembly and Care Advice".

And remember, do not tighten until each step is completed or instructed.

Parts List

Hardware List

	#1 x 1pc Cabinet body
	#2 x 4pcs Leg
	#3 x 2pcs Bottom plate
	#4 x 4pcs Riser
	#5 x 1pc Backplane
	#6 x 1pc panel
	#7 x 2pcs Drawer Top
	#8 x 1pc In the mirror
	#9 x 2pcs side mirror
	#10 x 2pcs Mirror connecting rod

	#A x 5pcs Bolt Ø1/4" x 2"
	#B x 5pcs Barrel Nut Ø1/4"
	#C x 8pcs Bolt Ø1/4"x1-3/8"
	#D x 8pcs Lock Washer Ø1/4"
	#E x 8pcs Flat Washer Ø5/16"
	#F x 1pc Allen Key 4mm
	#G x 2pcs Connect Iron
	#H x 4pcs Wood Screw #3 x 1/2"



Attach legs (#2) to the bottom holes of the cabinet body (#1).

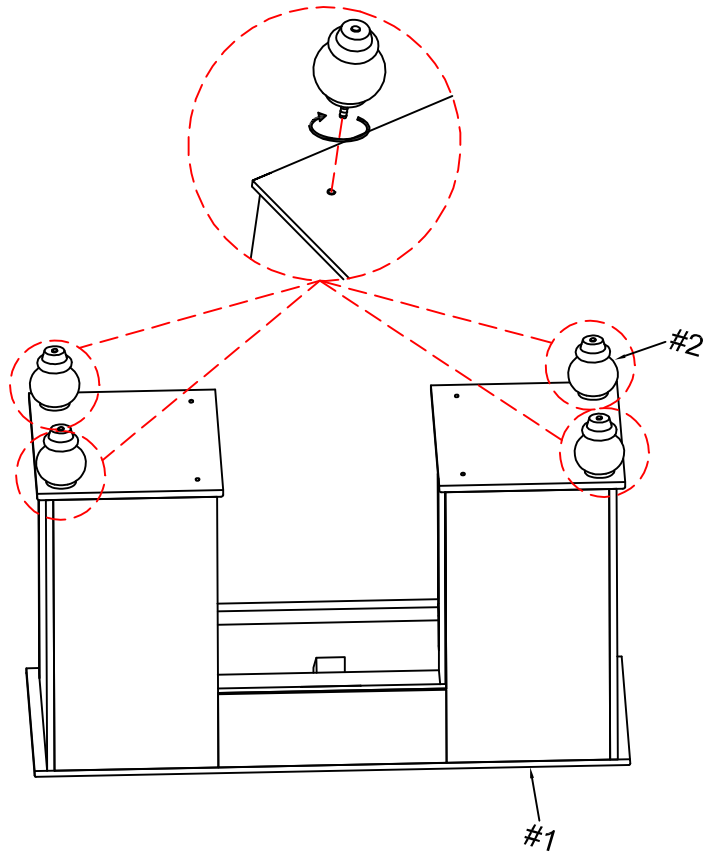

Align and attach the risers (#4) to the holes of the bottom plate (#3).

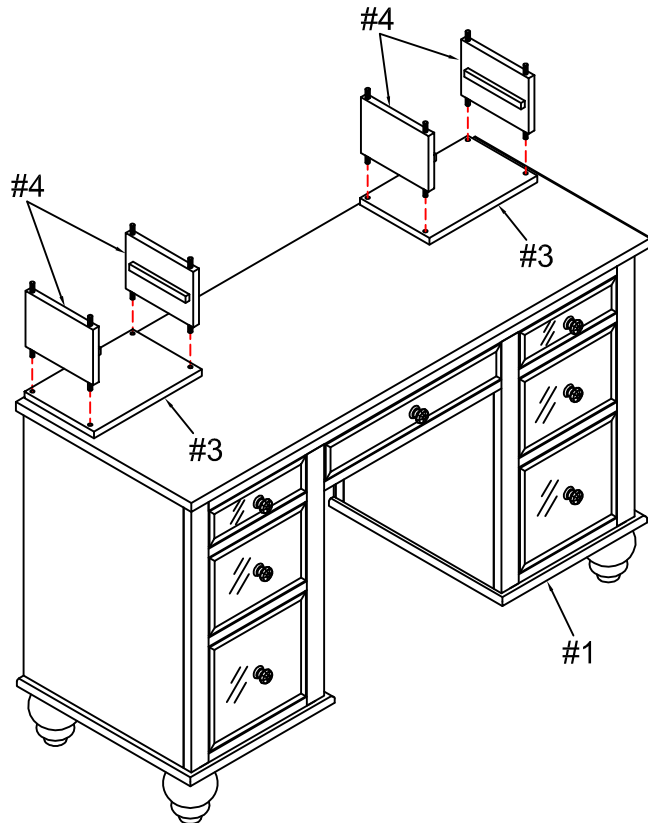

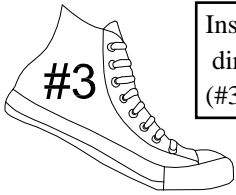

Insert barrel nuts (#B) to the holes of the bottom plate (#3). Make sure the barrel nut (#B) holes are facing the same direction as the hole on the back side of bottom plate (#3). Align backplane (#5) to the holes of the bottom plate (#3), then secure by attaching bolts (#A) to barrel nuts (#B).

#A x 2pcs
#B x 2pcs

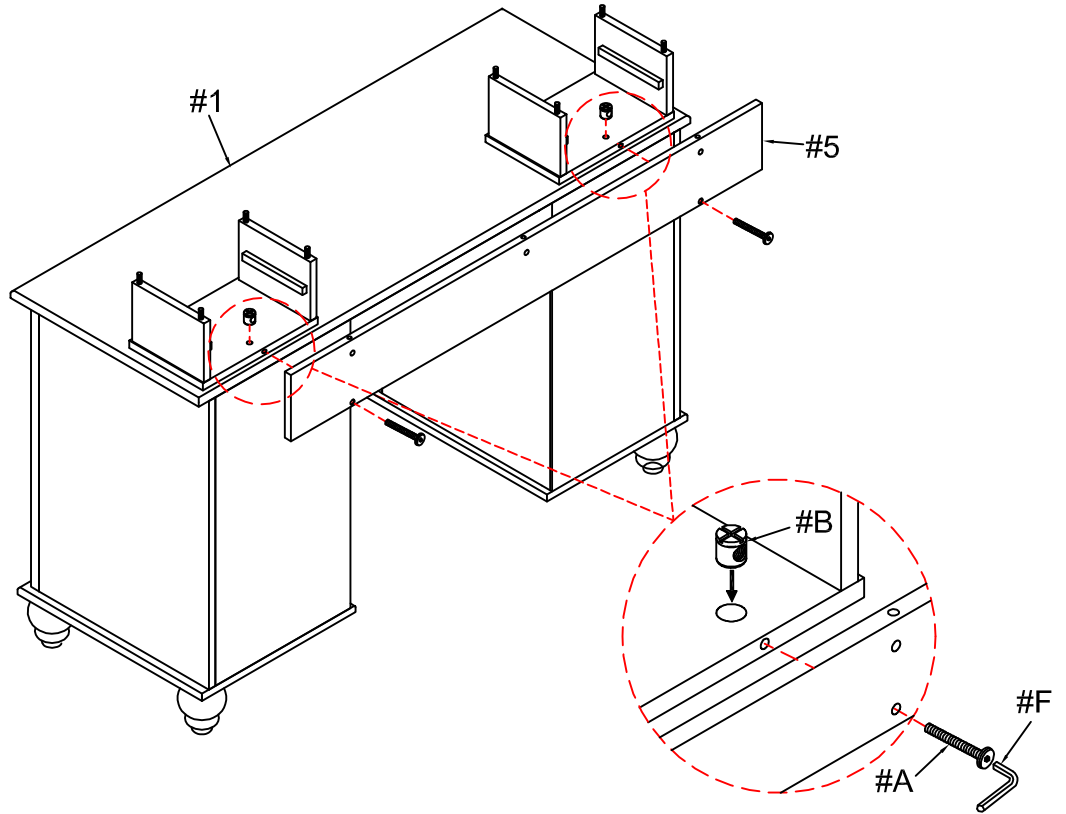

Align the panel (#6) to the holes and wood dowels of the rest of the cabinet. Insert barrel nuts (#B) to the holes of the backplane (#5) and make sure the barrel nut hole is facing upwards. Secure by attaching bolts (#A) to the barrel nuts (#B).

#A x 3pcs
#B x 3pcs

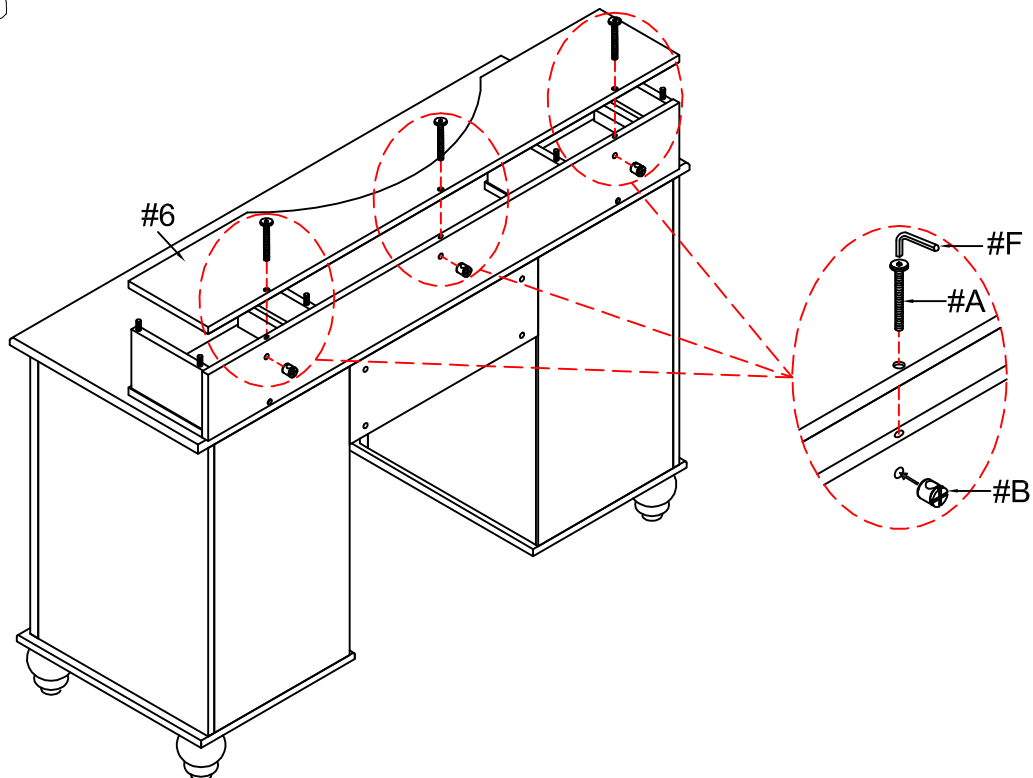



Prepare 4 bolts assembly by inserting lock washer (#D), then flat washer (#E) onto bolts (#C). Align mirror connecting rods (#10) to the holes located in the back side of the cabinet body (#1). Secure with bolts (#C).

- #C x 4pcs
- #D x 4pcs
- #E x 4pcs

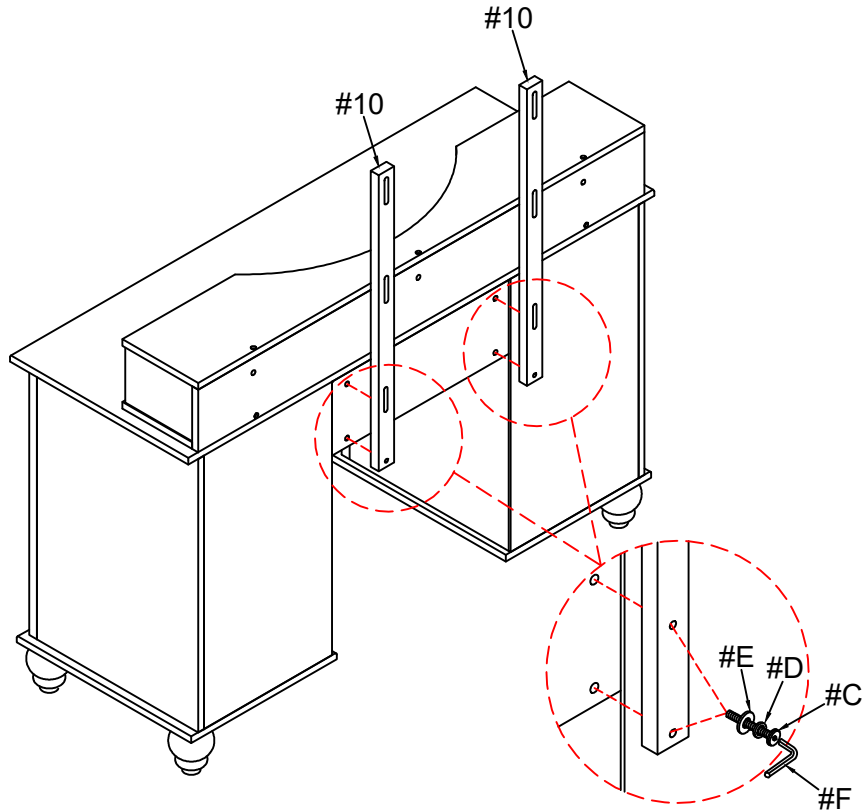

Prepare 4 bolts assembly by inserting lock washer (#D), then flat washer (#E) onto bolts (#C). Align mirror (#8) to the holes of the mirror connecting rod (#10), then secure with bolts (#C).

- #C x 4pcs
- #D x 4pcs
- #E x 4pcs
- #G x 2pcs
- #H x 4pcs

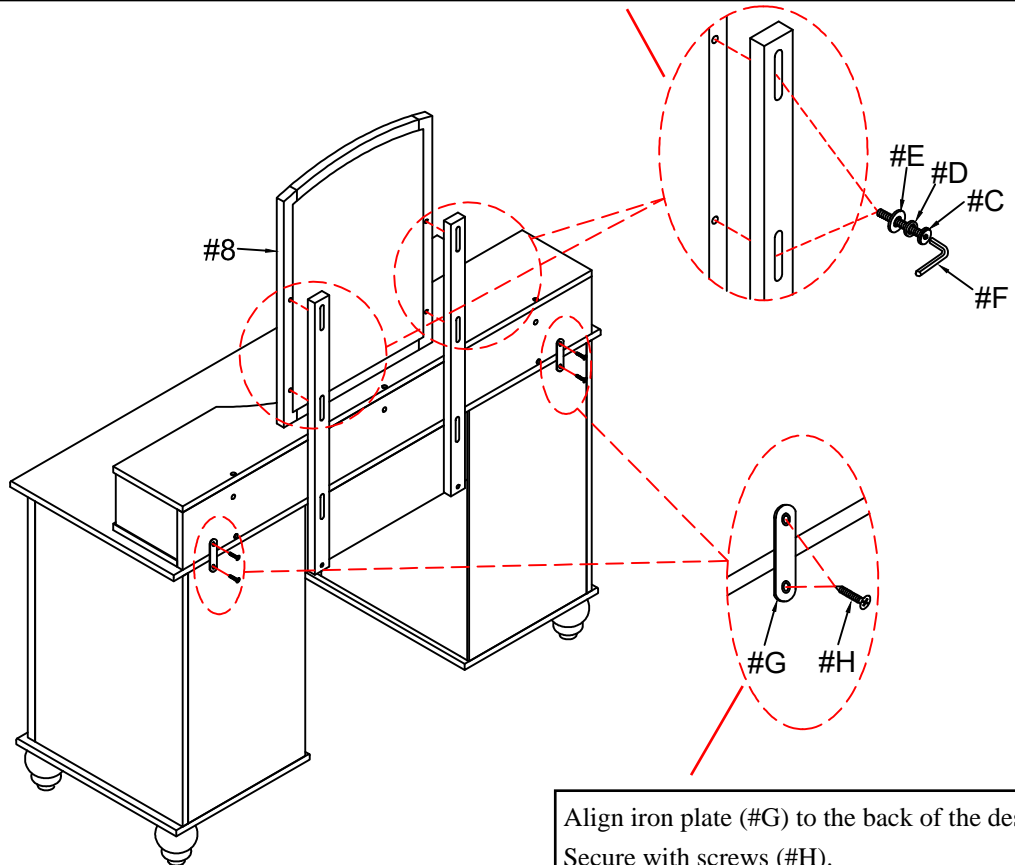

Align iron plate (#G) to the back of the desk. Secure with screws (#H).



Slide the side mirrors (#9) down to the metal pole of the middle mirror (#8).

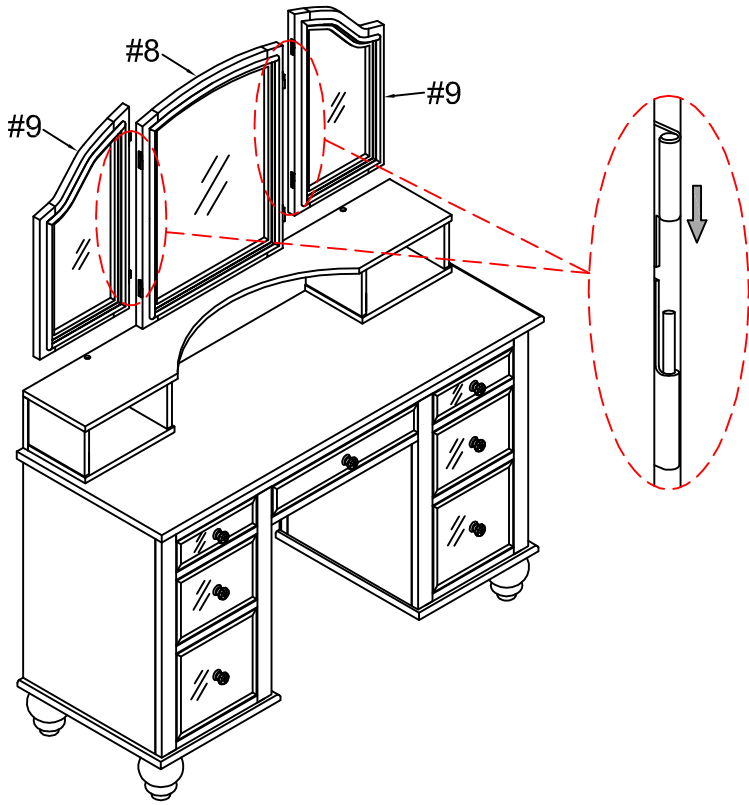

Unscrew the knob, then reattach the knob to the outside of the drawer.

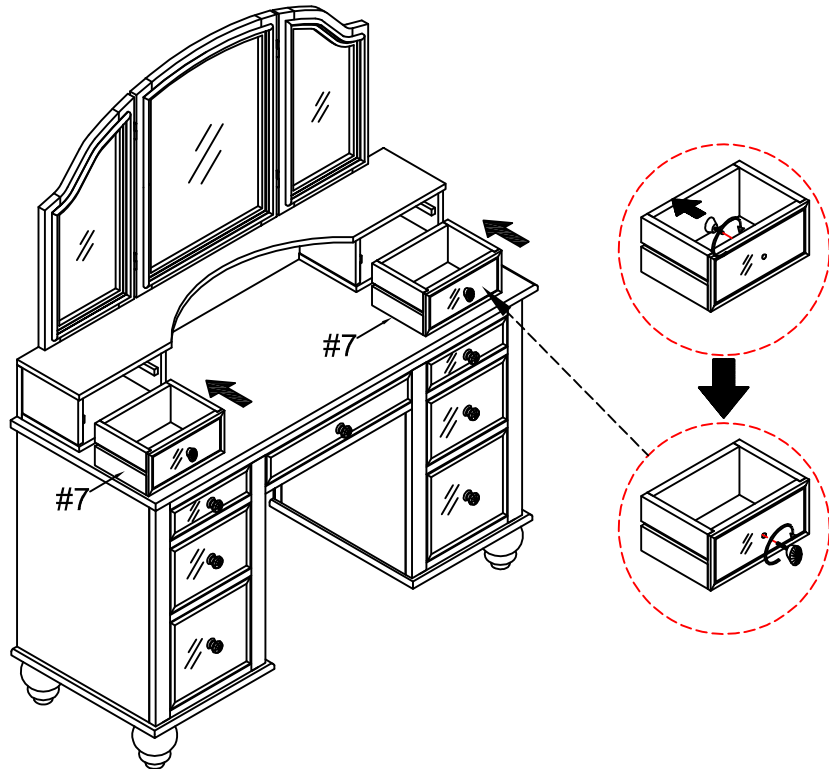



Before you begin, please read Page 2 of "Assembly and Care Advice".

And remember, do not tighten until each step is completed or instructed.

Parts List

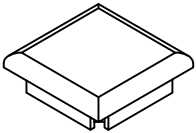

#1 x 1pc
Seat

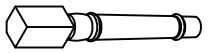

#2 x 4pcs
Leg



#D x 1pc
Allen Key 4mm

Hardware List



#A x 8pcs
Bolt Ø1/4" x 2"



#B x 8pcs
Lock Washer Ø1/4"



#C x 8pcs
Flat Washer Ø5/16"



Prepare 8 bolts assembly by inserting lock washer (#B), then flat washer (#C) onto bolts (#A).
Align legs (#2) to the holes of the cushion (#1), then secure with bolts (#A).

#A x 8pcs
#B x 8pcs
#C x 8pcs

