

# Assembly Instructions

**Caution : You must read this before you proceed**

## **TABLE**



**CAUTION :** This Table is NOT a TOY.



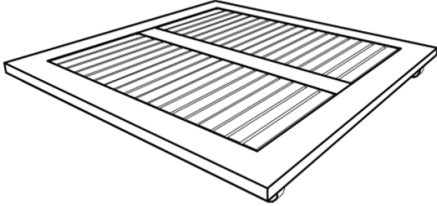
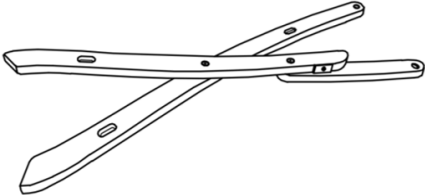
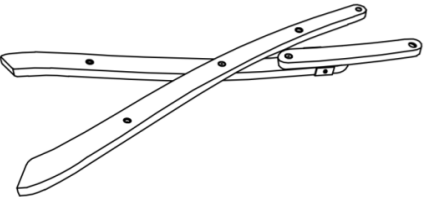
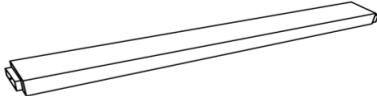
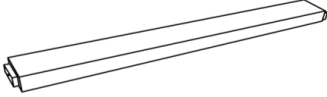

Keep your child / children at bay in the process of assembly.

For turning the Table and to prevent damage to the Table, 02 persons may be needed to execute this action.

# Parts List

Label	Picture	Description	QTY
A		Table Top	1
B		First leg	1
C		Second leg	1
D		Long support bar	2
E		Short support bar	1

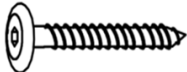
# Hardware

Label	Picture	Description	QTY
①		Bolt (M8x30mm)	5
②		Sleeve Nut (8x15mm)	5
③		Flat Washer (20x8.5x2mm)	5
④		Screw (6x50mm)	7
⑤		Allen Key	2

# Assembly Preparation

## Before Beginning Assembly:

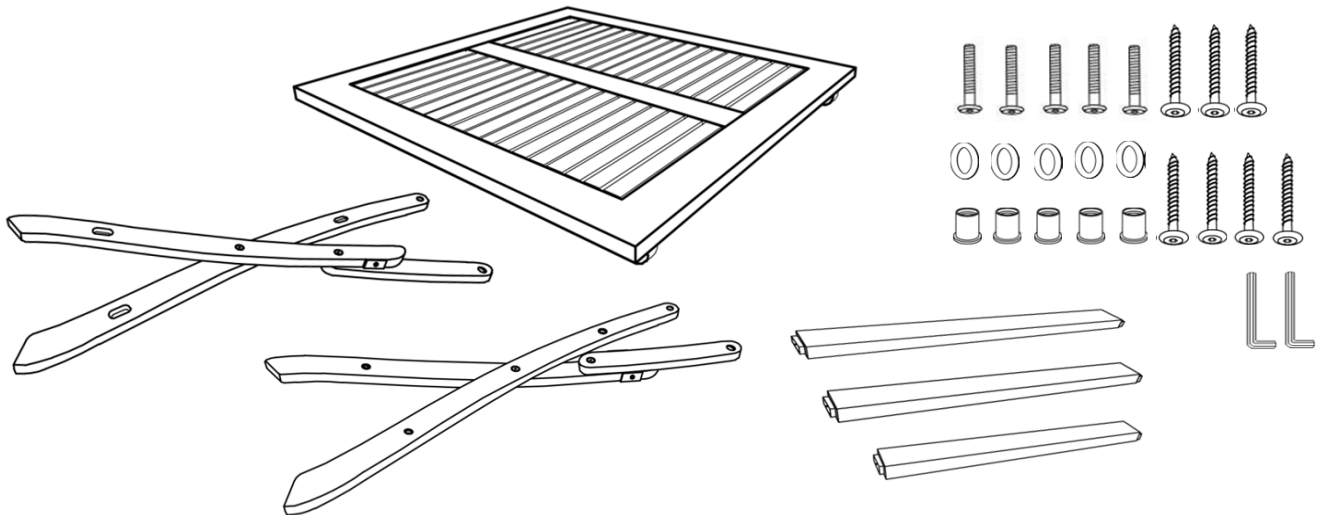

- Read instructions, cover to cover-



- Have 2 adults on hand for assembly-



- Do not assemble on flooring or carpet-



- Assemble on a clean non-marring surface (packing foam)-



- Save all packaging until finished-

# Assembly Steps

## Overview

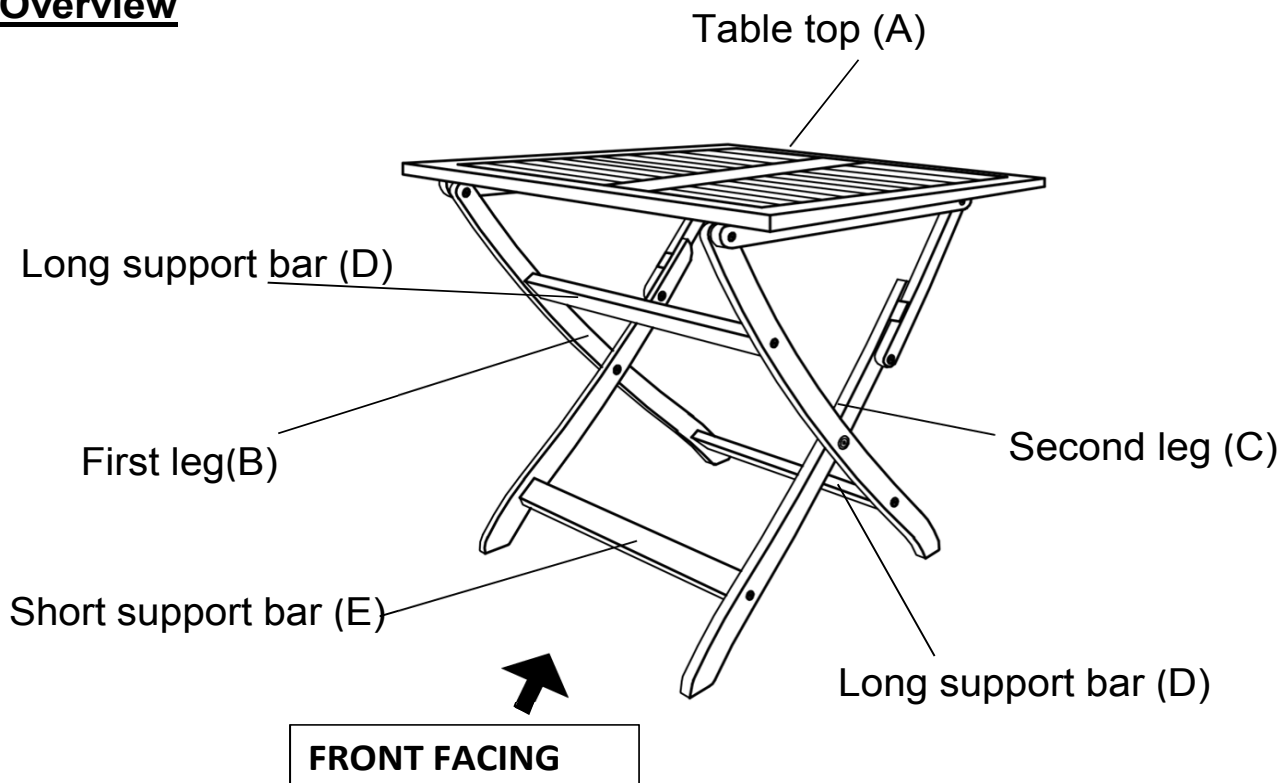

This Table has multiple parts and may require up to 30 minutes to assemble. To give you an overview of the Table parts, the above picture is to help you put the various parts into perspective. Please read through the instructions below to familiarise yourself with the parts and steps before assembly.

## Step 1

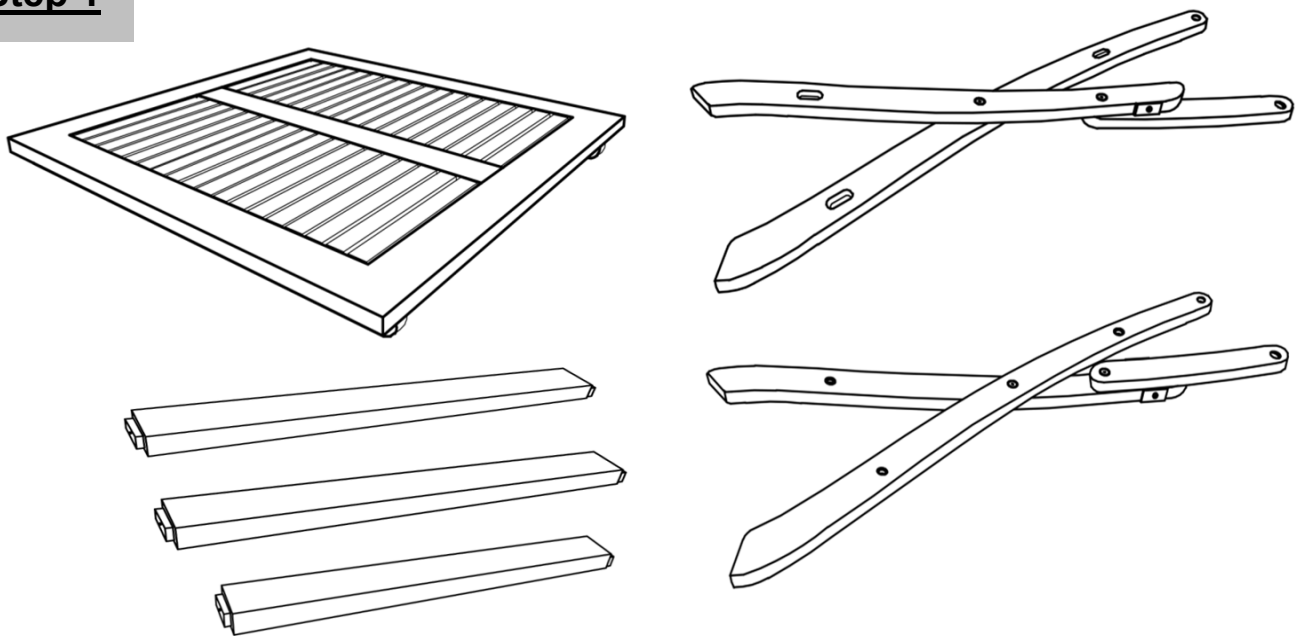

Unpack and place all parts on a clean, non-marring surface.

## Step 2

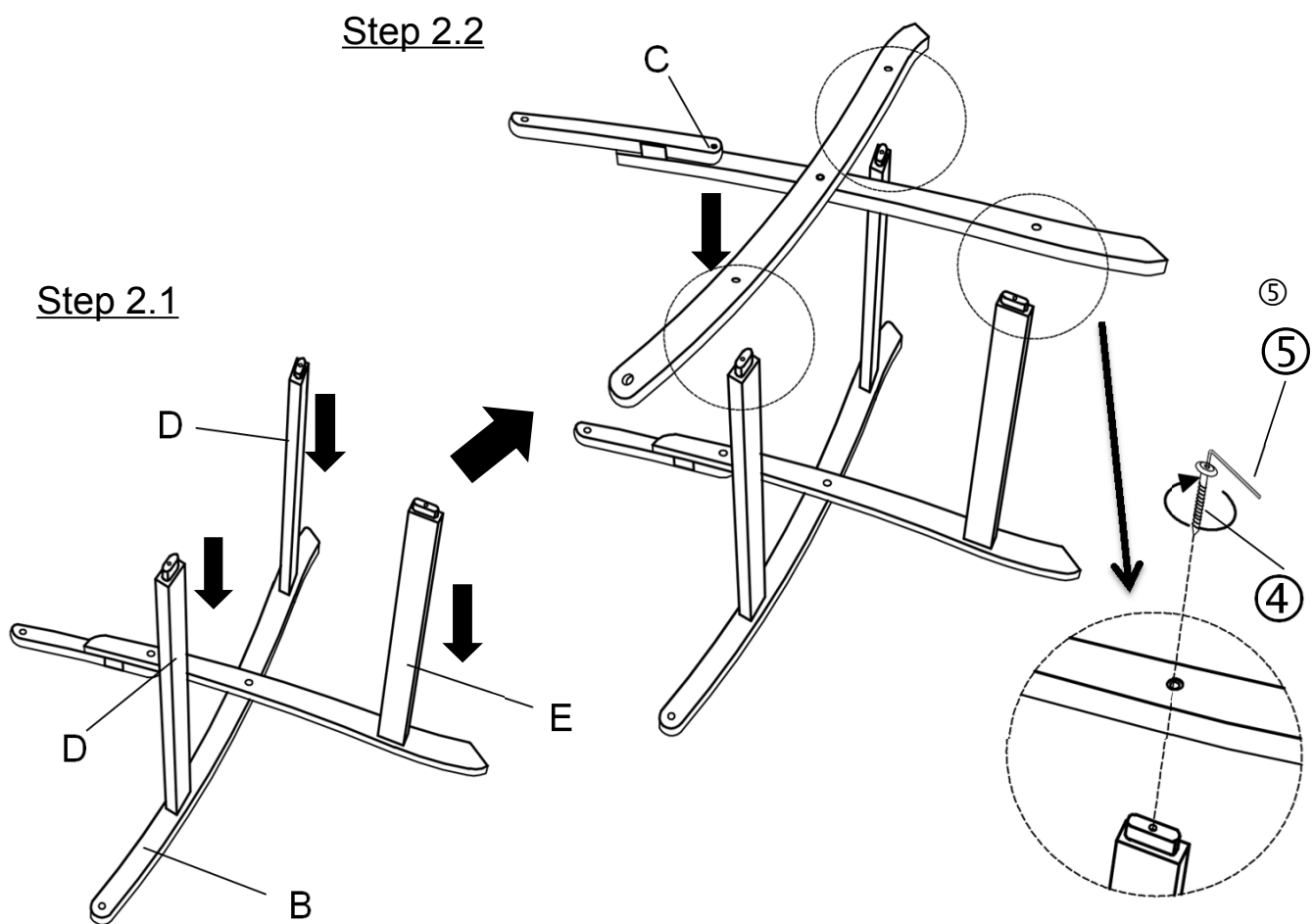

2.1) Position First leg (B) and 3 support bar (D), (E)

2.2) Attach Second Leg (C) to 3 support bar (D), (E) by using 3 Screw (④) and Allen Key (⑤)

**Do not fully tighten the Screws.**

### Step 3

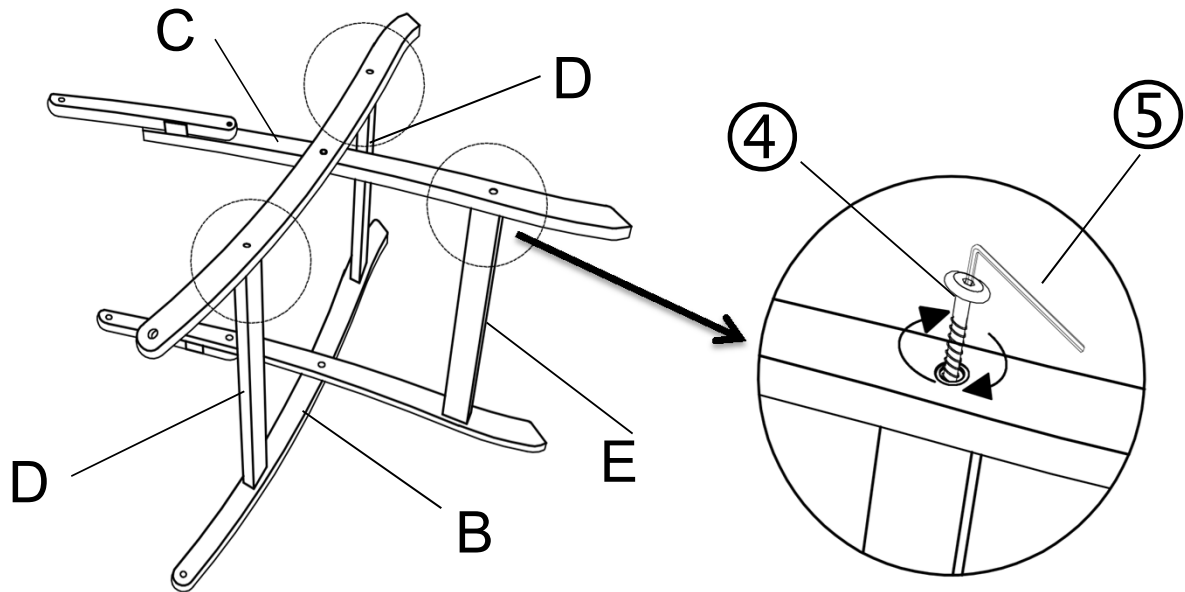

- 3.1) With assistance from your partners, turn the Leg frame into the other side.  
3.2) Repeat the same process of step 2.2 to secure First Leg (B) to 3 support bars (D), (E)  
**Do not fully tighten the Screws.**

### Step 4

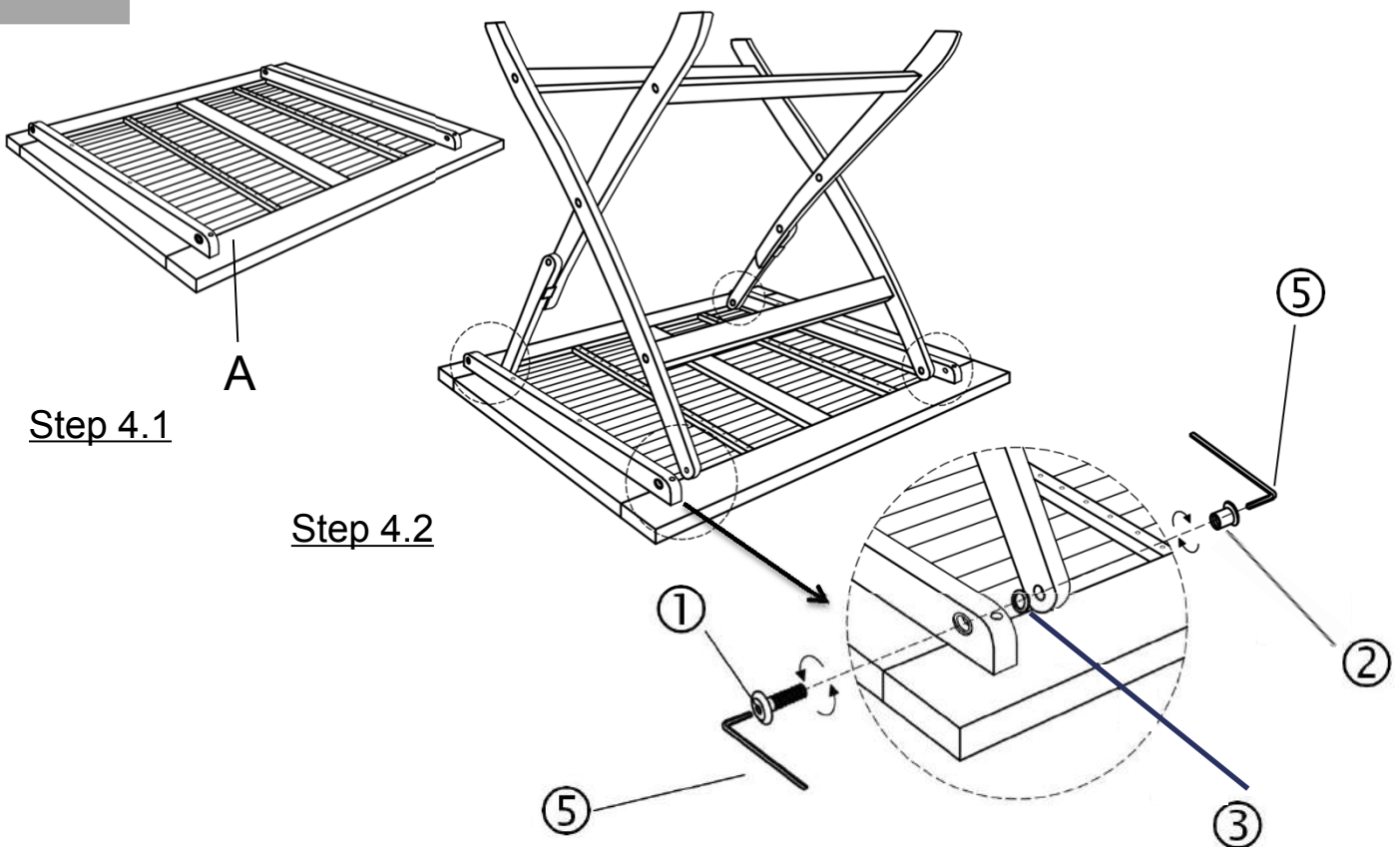

- 4.1) Turn the Table Top (A) up side down as shown in above picture  
4.2) Attach Leg frame to Table Top (A) by using Bolt (①), Sleeve nut (②), Flat Washer (③)  
and Allen Key (⑤)  
Repeat the same process with the other 3 positions  
**Do not fully tighten the Bolts.**

### Step 5



Turn the Table back to normal flat ground  
EXERT pressure, floorwards, onto the Table.  
This pressure will help the Legs and Table Top reach alignment at all joints.  
Check for wobbles.  
In a sequential manner, gradually tighten all Bolts until evenly secured.  
Inspect the Table and make sure all parts are adequately connected.  
Your Table is ready for use.  
This Table can only be used on a flat, level surface.



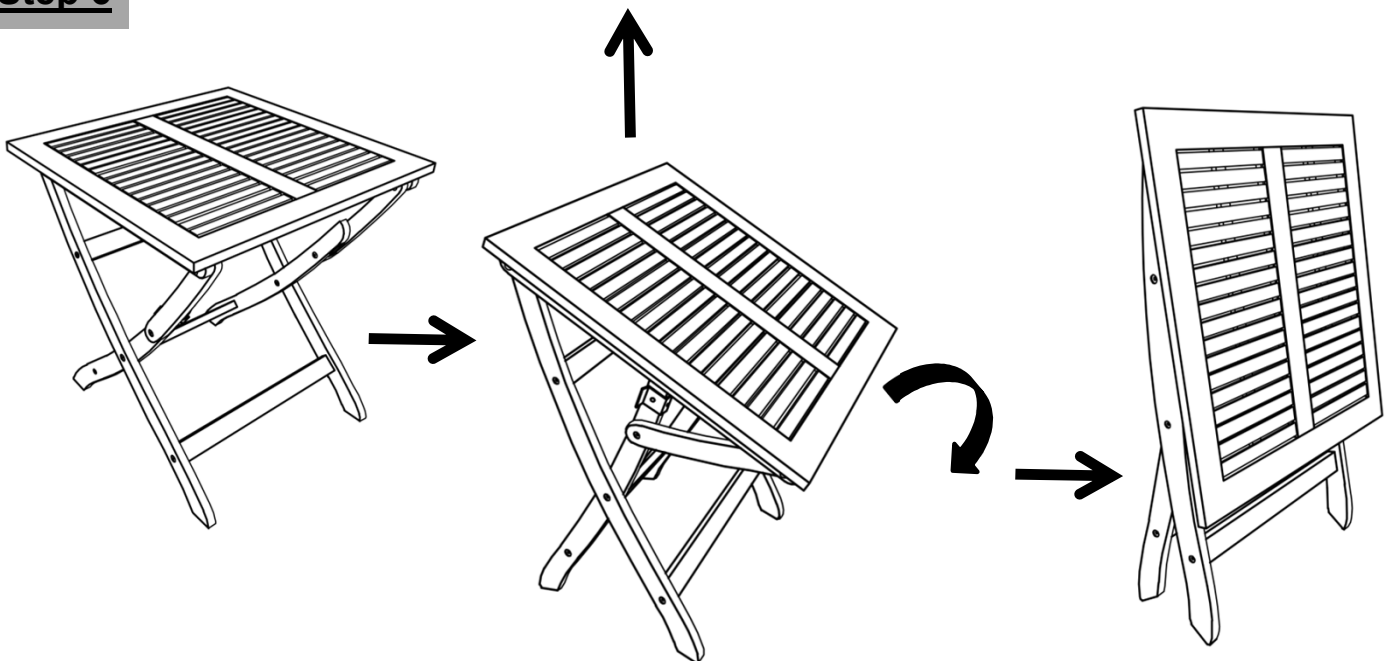















### Step 6



**Optionally, when you don't use the Table, you can fold the Table as picture shown**

**To fold**, pull the Table top up and fold Leg Frame as indicated by the arrows, by hand, until the Table folds shut

## Care & Maintenance

-   ● Do not put hot items directly on furniture surface
  -   ● Do not clean furniture with harsh cleansers or polish.
  -   ● To obtain the longest lifespan of your outdoor products, minimizing exposure to direct sunlight is recommended.
  -   ● Children should not climb or jump on the furniture.
  -   ● Do not write on furniture without a padded barrier to protect the surface.
  -   ● To obtain the longest lifespan of your outdoor products, avoid extended and lengthy exposure to rain, snow, and direct sunshine. Whenever possible cover the product and /or place under patio or awnings.
  -   ● Not for commercial use. For residential use only .
  -   ● Stains may be removed with mild soap solution and damp cloth.
- 
-   ● Dust and pick-up spills using a clean, non-colored, lint-free cloth .

### Questions & Answers about Proposition 65

#### • What is Proposition 65?

Proposition 65 requires businesses to provide warnings to Californians about significant exposures to chemicals that cause cancer, birth defects or other reproductive harm. These chemicals can be in the products that Californians purchase, in their homes or workplaces, or that are released into the environment. By requiring that this information be provided, Proposition 65 enables Californians to make informed decisions about their exposures to these chemicals.

Proposition 65 also prohibits California businesses from knowingly discharging significant amounts of listed chemicals into sources of drinking water.

Proposition 65 requires California to publish a list of chemicals known to cause cancer, birth defects or other reproductive harm. This list, which must be updated at least once a year, has grown to include approximately 900 chemicals since it was first published in 1987.

#### • What types of chemicals are on the Proposition 65 list?

The list contains a wide range of naturally occurring and synthetic chemicals that include additives or ingredients in pesticides, common household products, food, drugs, dyes, or solvents. Listed chemicals may also be used in manufacturing and construction, or they may be byproducts of chemical processes, such as motor vehicle exhaust.

#### • What does a warning mean?

If a warning is placed on a product label or posted or distributed at a workplace, a business, or in rental housing, the business issuing the warning is aware or believes that it is exposing individuals to one or more listed chemicals.

By law, a warning must be given for listed chemicals unless the exposure is low enough to pose no significant risk of cancer or is significantly below levels observed to cause birth defects or other reproductive harm.

#### • Where can I get more information on Proposition 65?

If you have specific questions on the administration or implementation of Proposition 65, you can contact OEHHHA's Proposition 65 program at [P65.Questions@oehha.ca.gov](mailto:P65.Questions@oehha.ca.gov), or by phone at (916) 445-6900.