

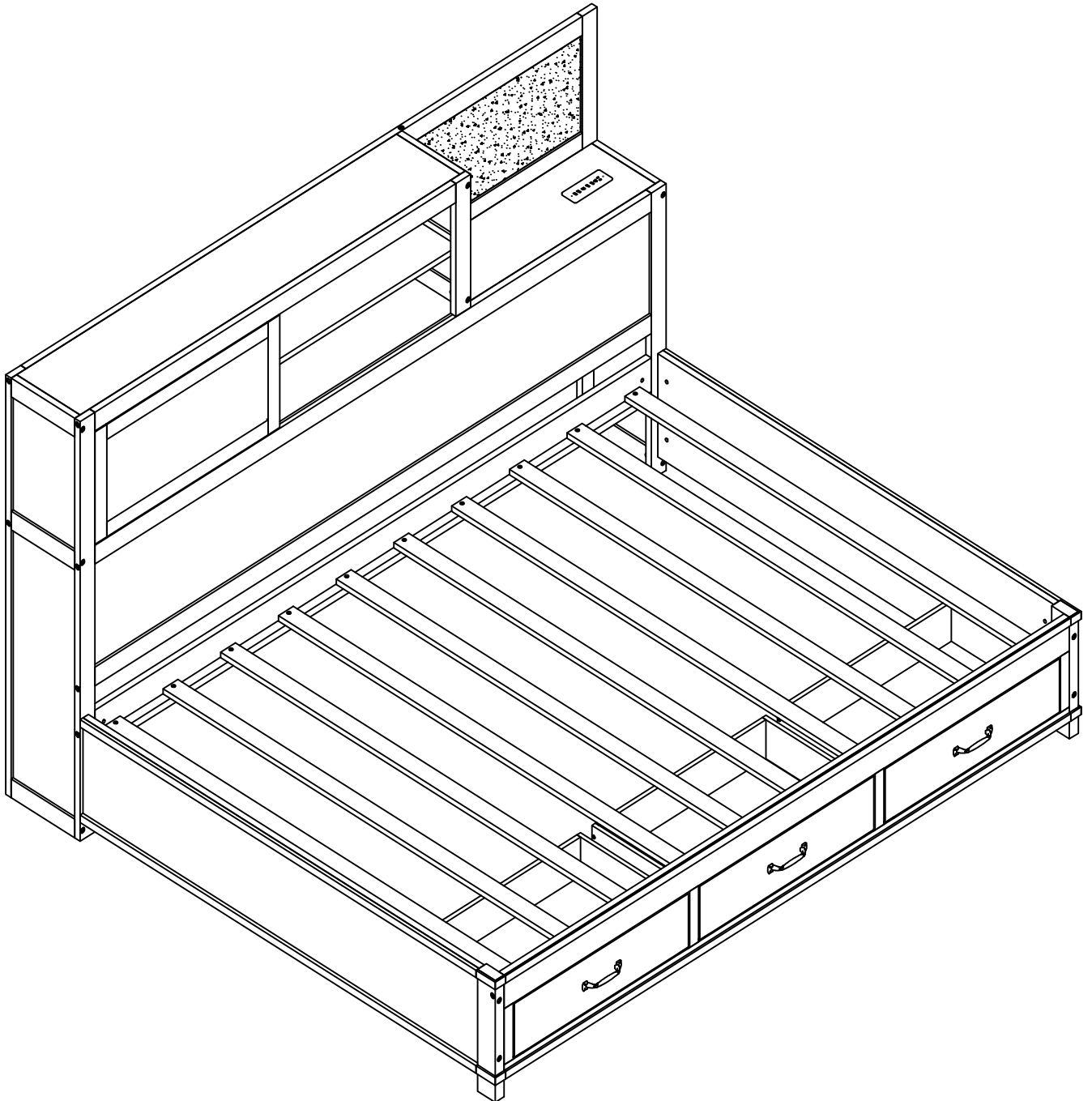

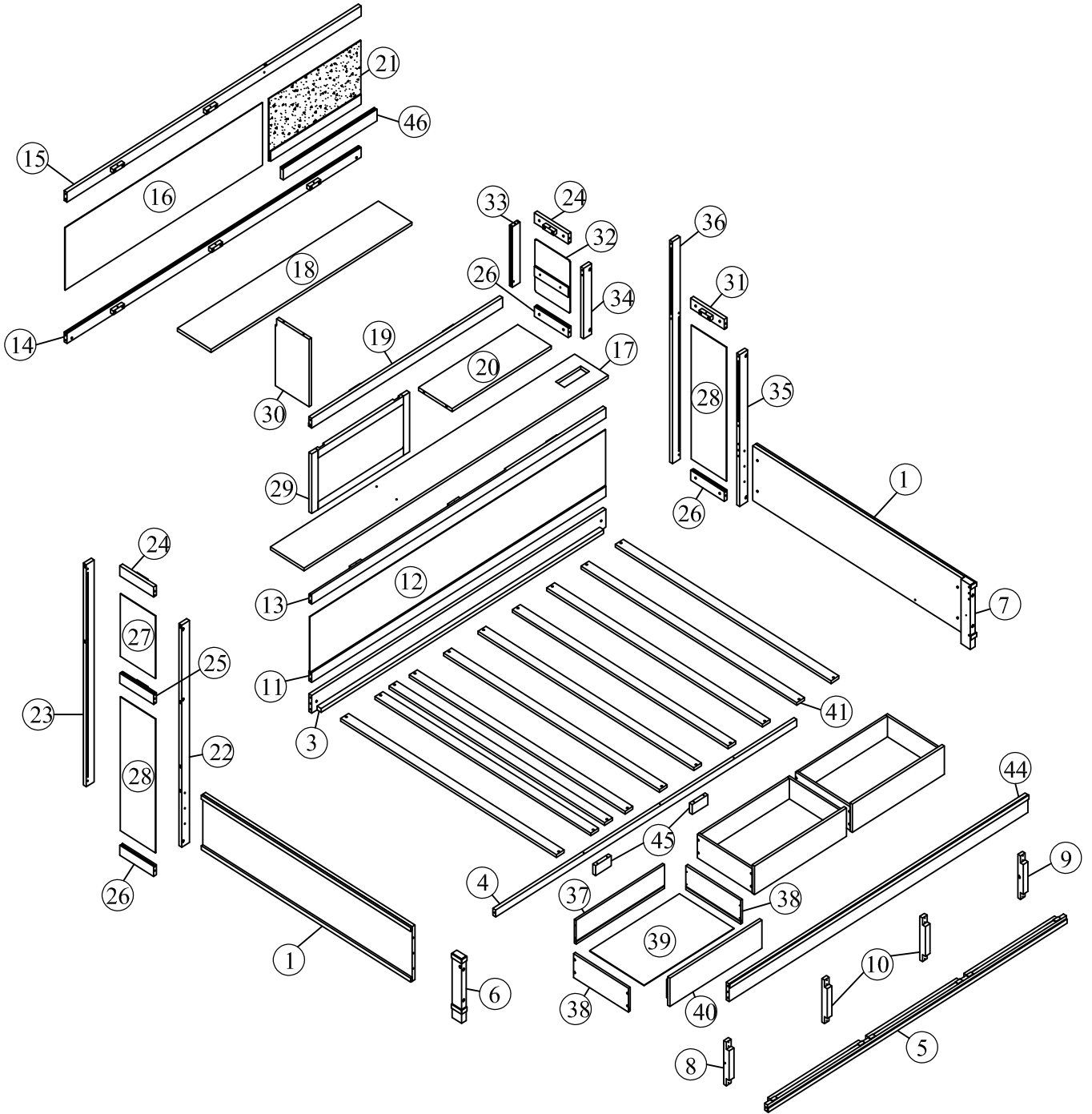



ASSEMBLY INSTRUCTION



Detail:

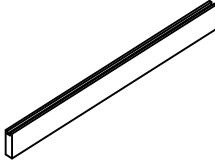
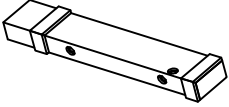
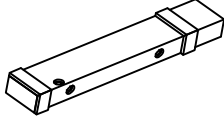
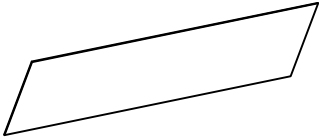
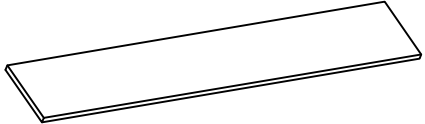

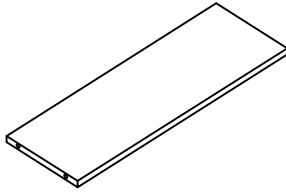
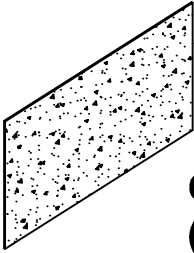
Part List

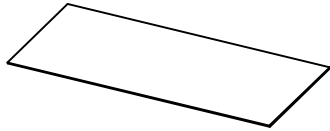
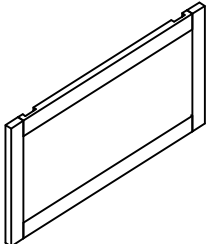
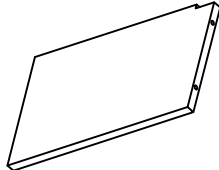
<p>① x2</p>  <p style="text-align: center;">Footboard</p>	<p>④⑥ x1</p>  <p style="text-align: center;">Wood bar</p>
<p>⑥ x1</p>  <p style="text-align: center;">Right (front) post leg at footboard</p>	<p>⑦ x1</p>  <p style="text-align: center;">Right (back) post leg at footboard</p>
<p>①⑥ x1</p>  <p style="text-align: center;">Panel at side rail</p>	<p>①⑧ x1</p>  <p style="text-align: center;">Bottom panel at side rail</p>
<p>①⑨ x1</p>  <p style="text-align: center;">Bottom wood bar at side rail</p>	<p>②⑦ x1</p>  <p style="text-align: center;">Small shelf at side rail</p>
<p>②① x1</p>  <p style="text-align: center;">Cork board (bulletin board)</p>	<p>②② x1</p>  <p style="text-align: center;">Left leg at headboard</p>
<p>②⑦ x1</p>  <p style="text-align: center;">Top panel at headboard</p>	<p>②⑧ x2</p>  <p style="text-align: center;">Panel at headboard</p>
<p>②⑨ x1</p>  <p style="text-align: center;">Door</p>	<p>③⑦ x1</p>  <p style="text-align: center;">Panel</p>

Part List

32 x1

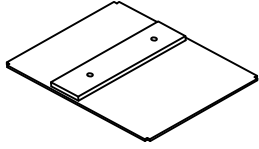

Panel at side rail

35 x1

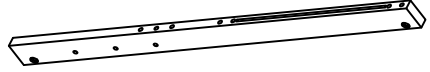

Leg post at footboard

37 x3

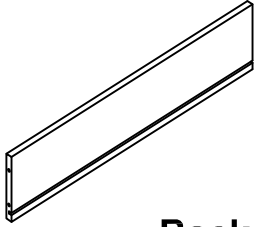

Back Drawers

38 x6

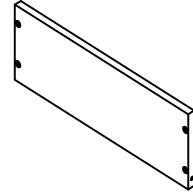

Side Drawers

39 x3

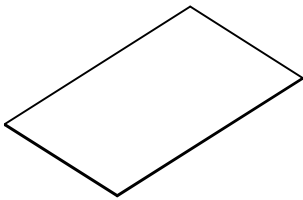





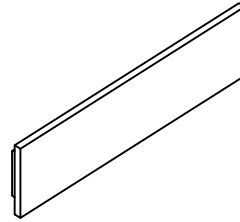



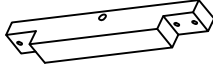

Bottom Drawers

40 x3

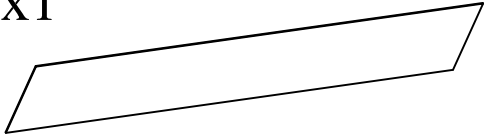

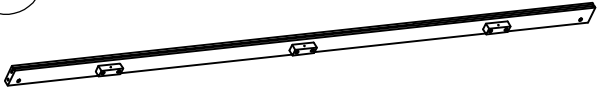
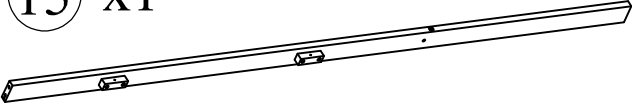

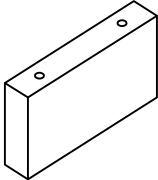

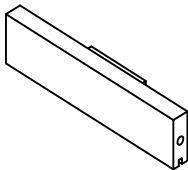
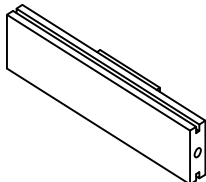

Front Drawers

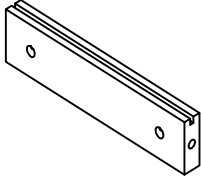
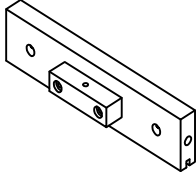
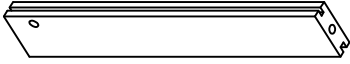





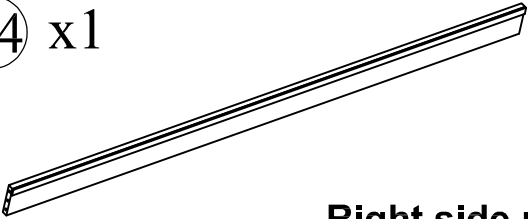



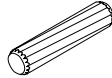
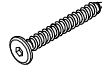



Part List

<p>⑤ x1</p>  <p style="text-align: center;">Wood bar under drawers</p>	<p>⑧ x1</p>  <p style="text-align: center;">Left wood bar</p>
<p>⑨ x1</p>  <p style="text-align: center;">Right wood bar</p>	<p>⑩ x2</p>  <p style="text-align: center;">Middle wood bar</p>
<p>⑪ x1</p>  <p style="text-align: center;">Bottom wood bar with groove</p>	<p>⑫ x1</p>  <p style="text-align: center;">Bottom panel of side rail</p>
<p>⑬ x1</p>  <p style="text-align: center;">Top wood bar with groove</p>	<p>⑭ x1</p>  <p style="text-align: center;">Bottom wood bar of side rail</p>
<p>⑮ x1</p>  <p style="text-align: center;">Top wood bar of rail</p>	<p>⑰ x1</p>  <p style="text-align: center;">Big shelf of side rail</p>
<p>④⑤ x2</p>  <p style="text-align: center;">Support wood at side rail</p>	<p>②③ x1</p>  <p style="text-align: center;">Back post at headboard</p>
<p>②④ x2</p>  <p style="text-align: center;">Wood bar at headboard</p>	<p>②⑤ x1</p>  <p style="text-align: center;">Wood bar with groove</p>

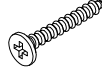
Part List

<p> ⓪ 26 x3  </p> <p style="text-align: center;">Wood bar at headboard</p>	<p> ⓪ 31 x1  </p> <p style="text-align: center;">Wood bar with groove</p>
<p> ⓪ 33 x1  </p> <p style="text-align: center;">Back wood bar at side rail</p>	<p> ⓪ 34 x1  </p> <p style="text-align: center;">Turn on climbing</p>
<p> ⓪ 36 x1  </p> <p style="text-align: center;">Back post leg at footboard</p>	<p> ⓪ 4 x1  </p> <p style="text-align: center;">Wood bar at side rail</p>
<p> ⓪ 3 x1  </p> <p style="text-align: center;">Left side rail</p>	<p> ⓪ 41 x10  </p> <p style="text-align: right;">Slats</p>
<p> ⓪ 44 x1  </p> <p style="text-align: center;">Right side rail</p>	

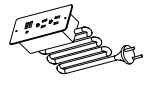
Hardware List

No.	OUTLOOK	DESC	QTY
(A)		Dowel Ø8*30mm	35pcs
(B)		Screws M6*45mm	2pcs
(C)		Bolts M6*100mm	4pcs
(D)		Bolts M6*90mm	12pcs
(E)		Bolts M6*70mm	6pcs
(G)		Cross dowel M6*13mm	22pcs
(H)		Cross dowel Ø10*10mm	15pcs
(I)		Flat head screw #8*60mm	20pcs
(J)		Flat head screw #8*30mm	20pcs
(K)		Flat head screw #8*25mm	57pcs
(L)		Flat head screw #8*15mm	3pcs
(M)		Flat head screw #7*12mm	18pcs
(N)		Sliding Rails Kenlin	3pcs
(O)		Sliding Rails Kenlin	3pcs
(P)		USB	1pc
(Q)		Pat L	3pcs
(R)		Allen key 60*22*4mm	1pc

ASSEMBLY TOOLS REQUIRED (NOT INCLUDED)

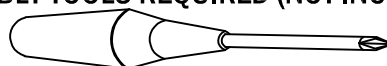

Hardware List

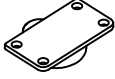
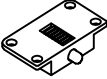
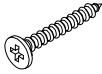
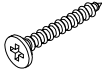

No.	OUTLOOK	DESC	QTY
S		Handle	3pcs
T		Wardrobe Black Plastic Plate Dia Wheel Sliding Door Roller	2pcs
U		Wardrobe Black Plastic Plate Dia Wheel Sliding Door Roller	2pcs
X		Flat head screw #7*12mm	12pcs
W		Flat head screw #8*50mm	4pcs

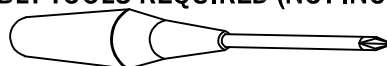
ASSEMBLY TOOLS REQUIRED (NOT INCLUDED)

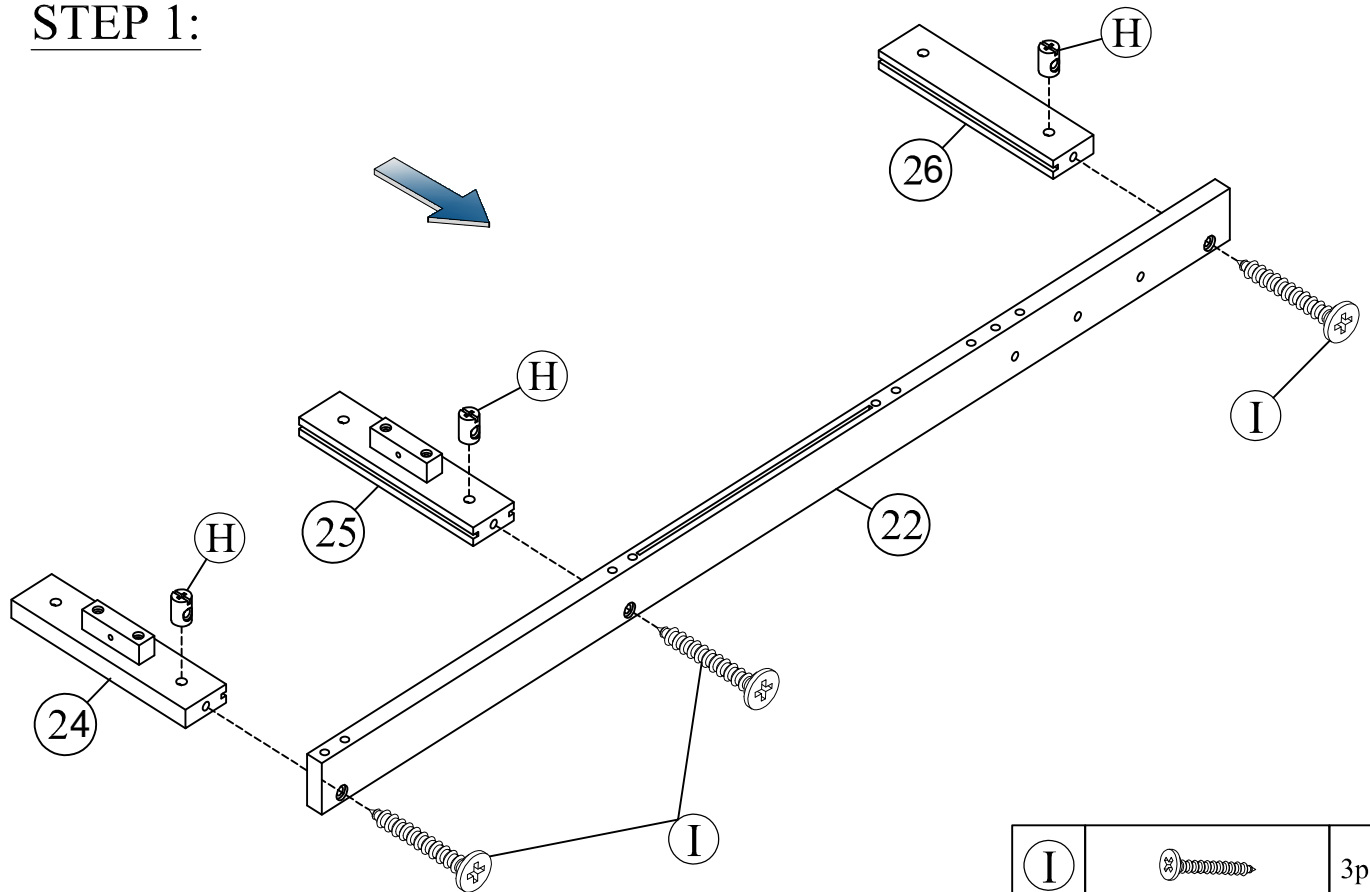

STEP 1:



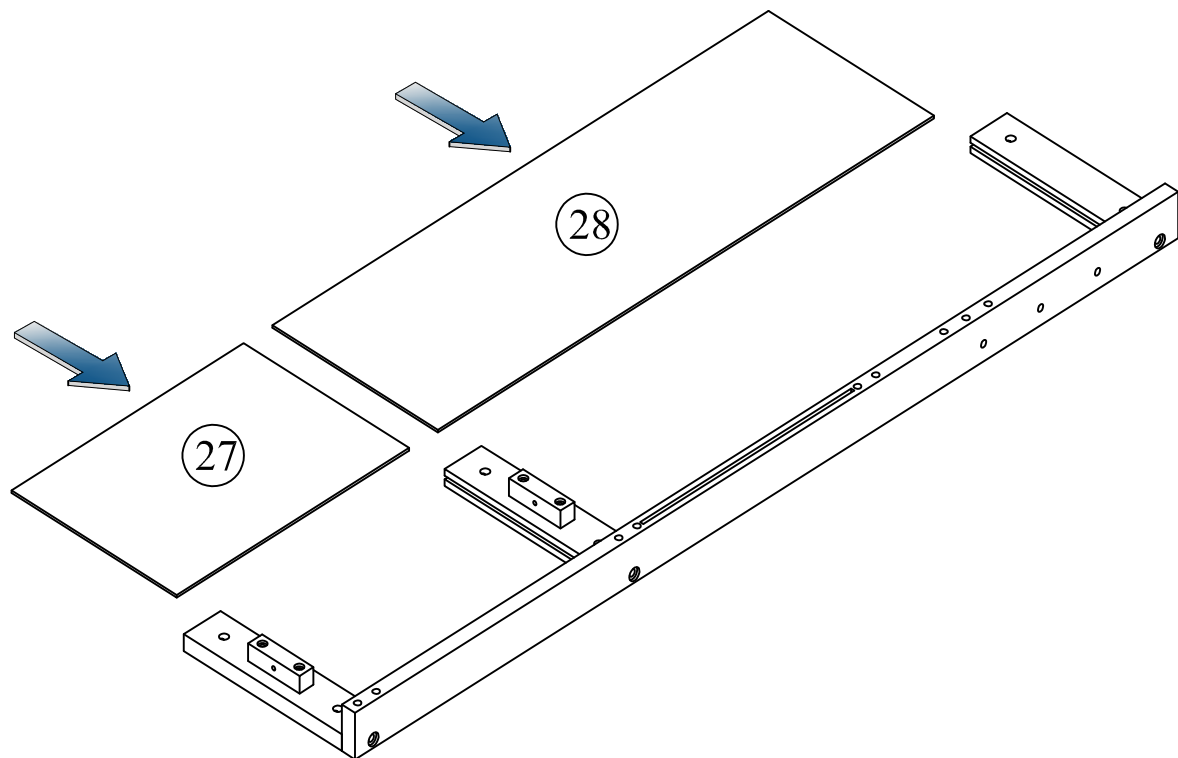

I		3pcs
H		3pcs

STEP 2:



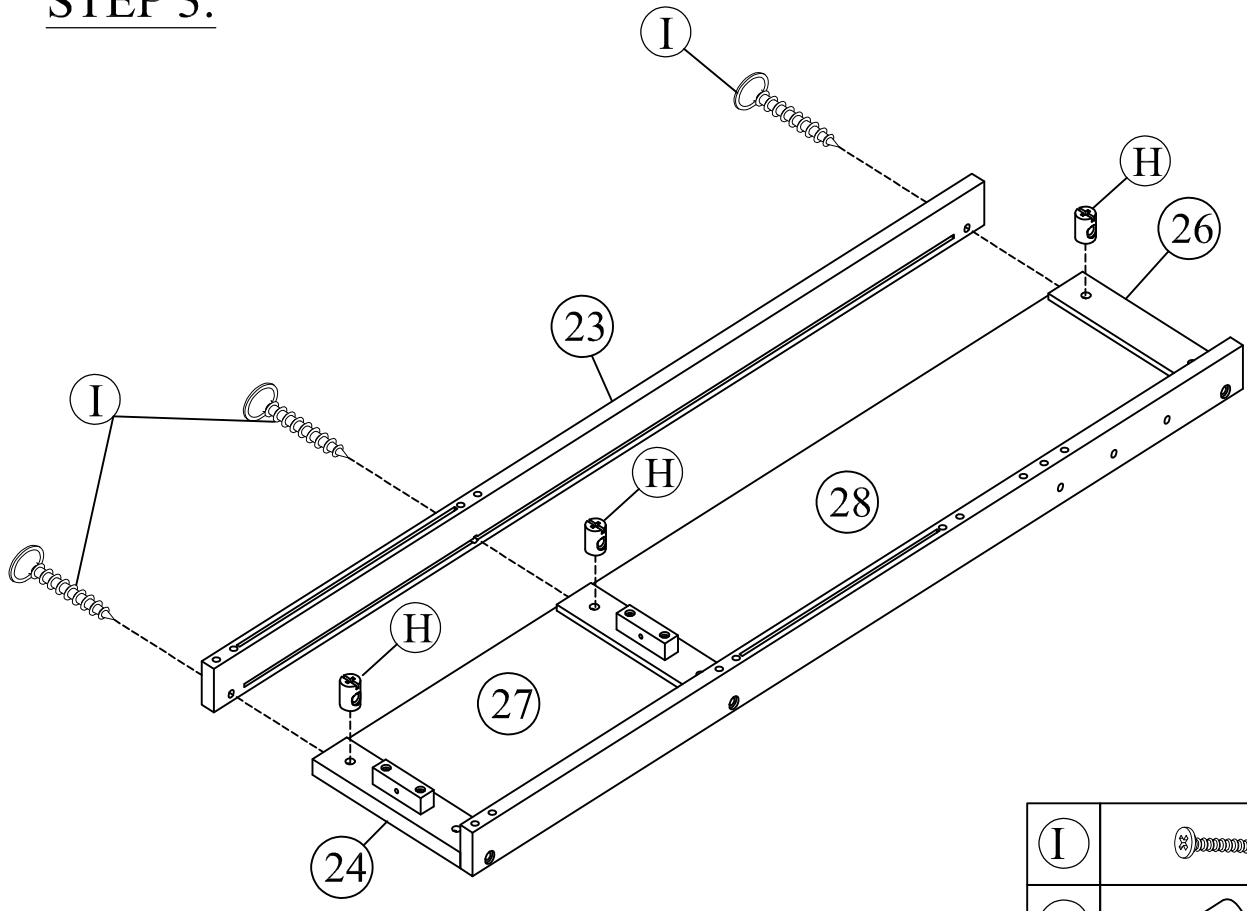

STEP 3:

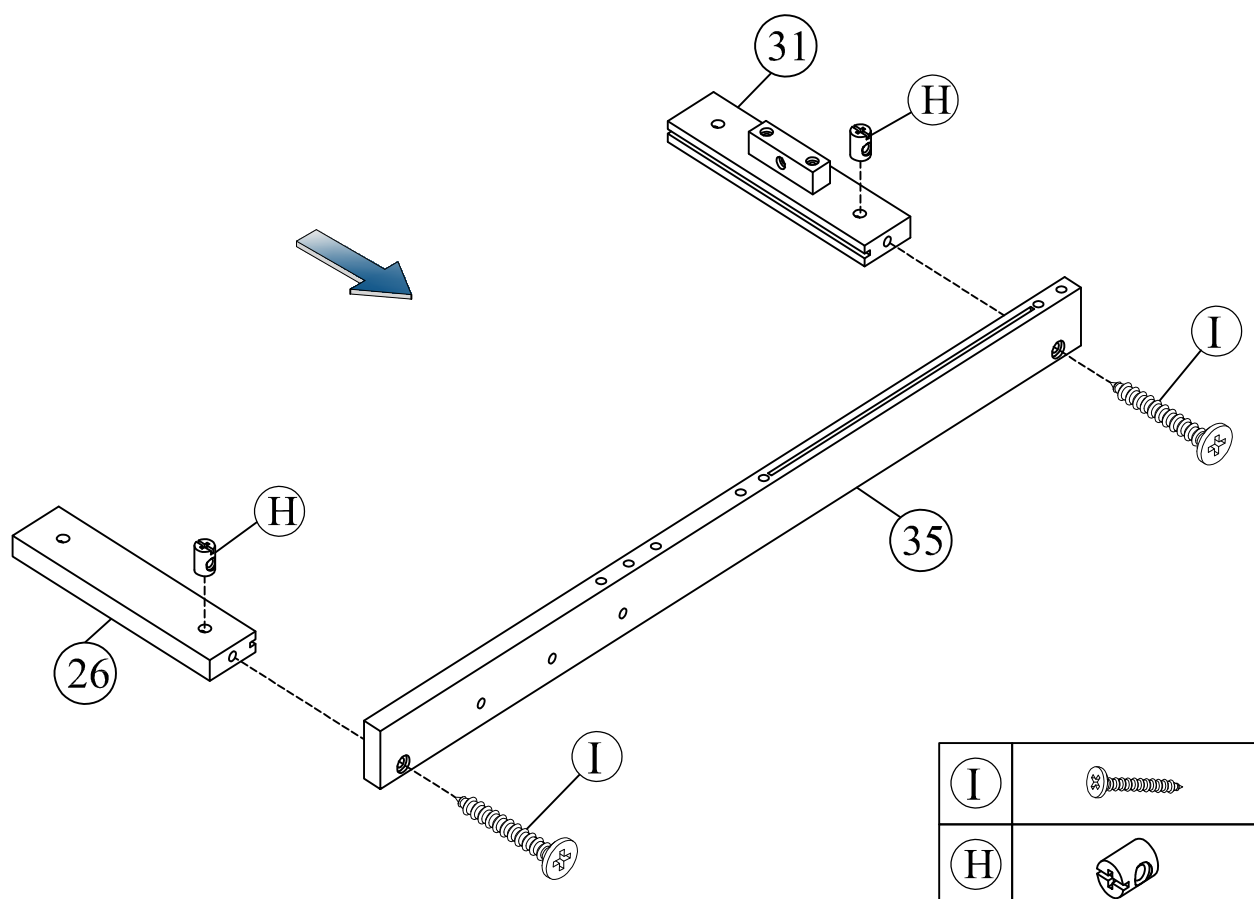

I		3pcs
H		3pcs

STEP 4:



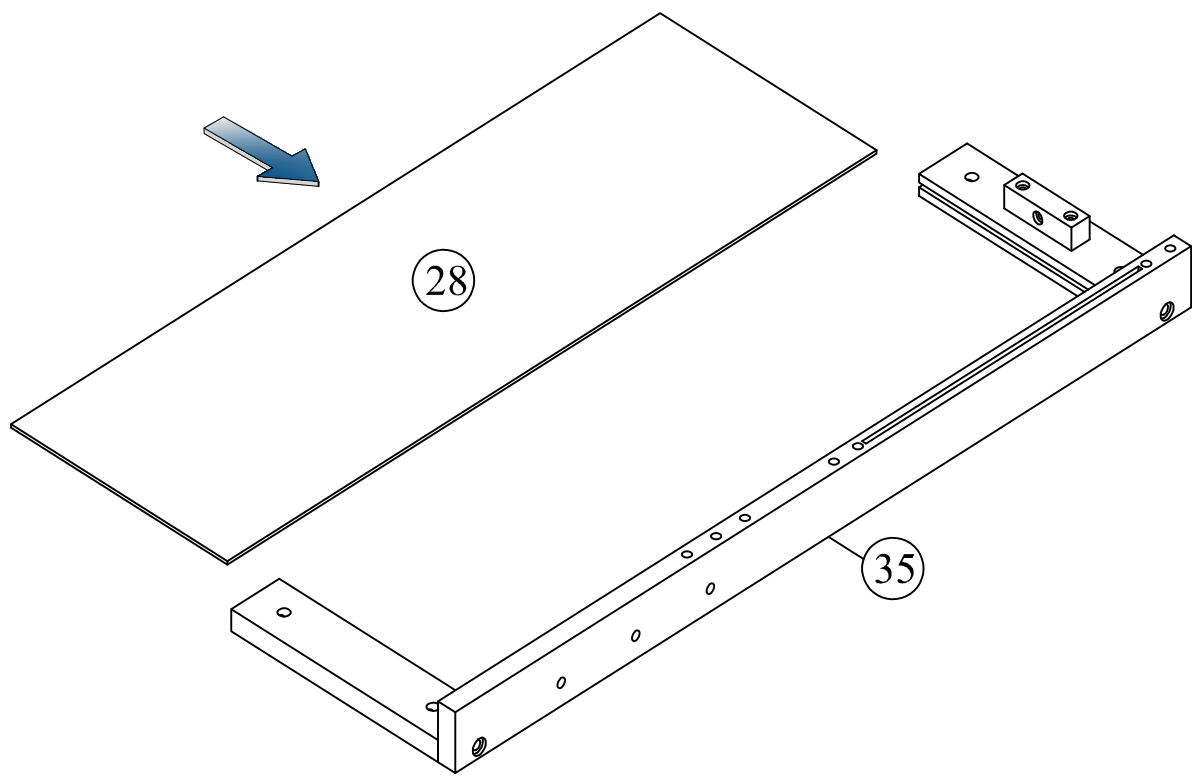

I		2pcs
H		2pcs

STEP 5:

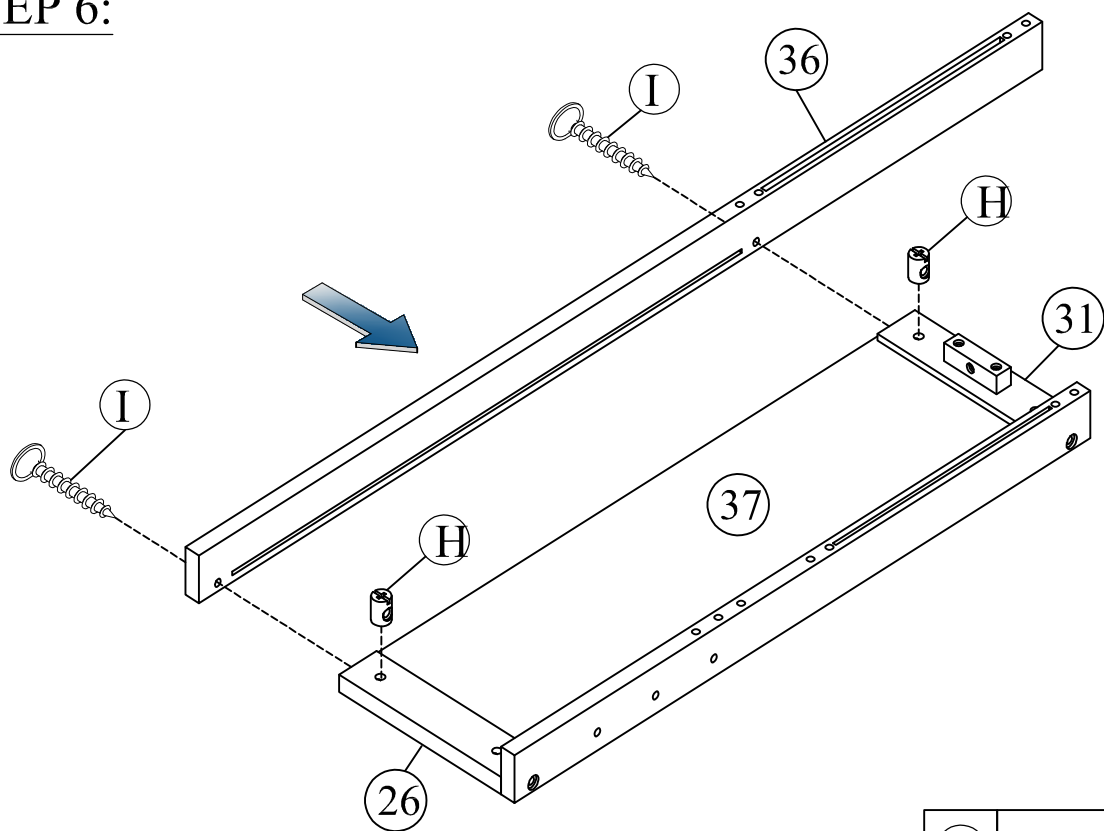

STEP 6:



I		2pcs
H		2pcs

STEP 7:

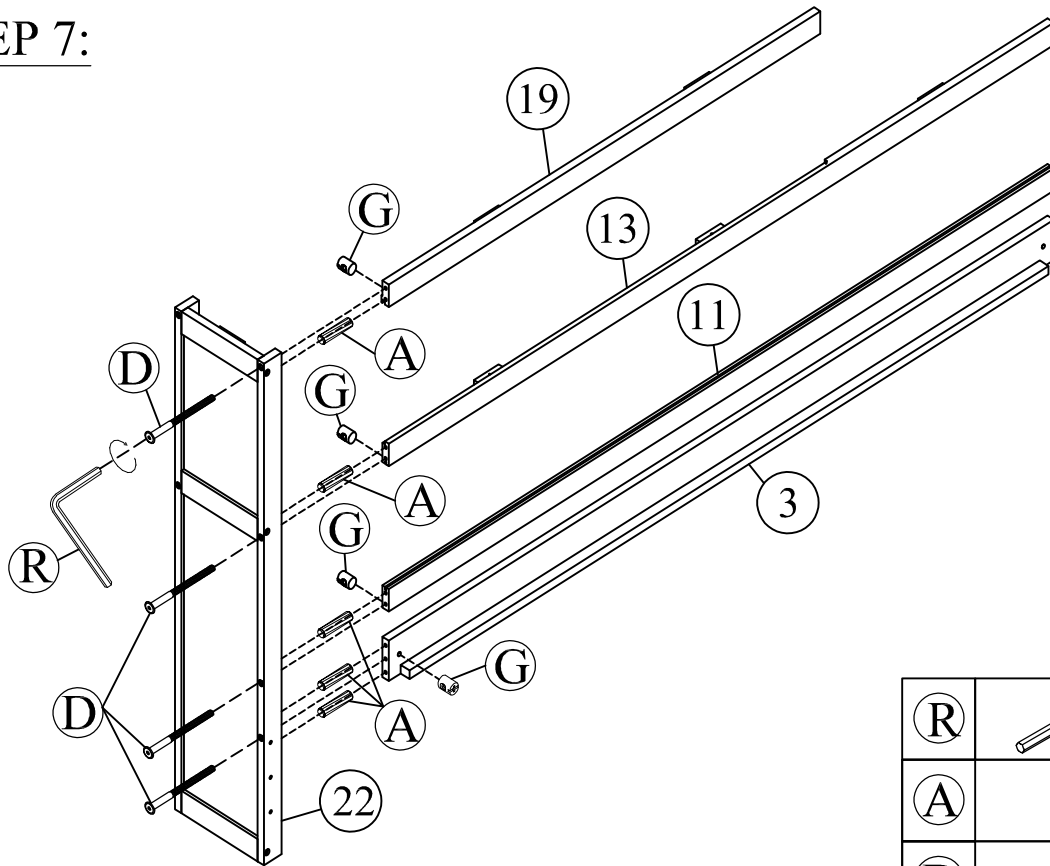

(R)		1pc
(A)		5pcs
(D)		4pcs
(G)		4pcs

Note :
Do not lock the bolt.

STEP 8:

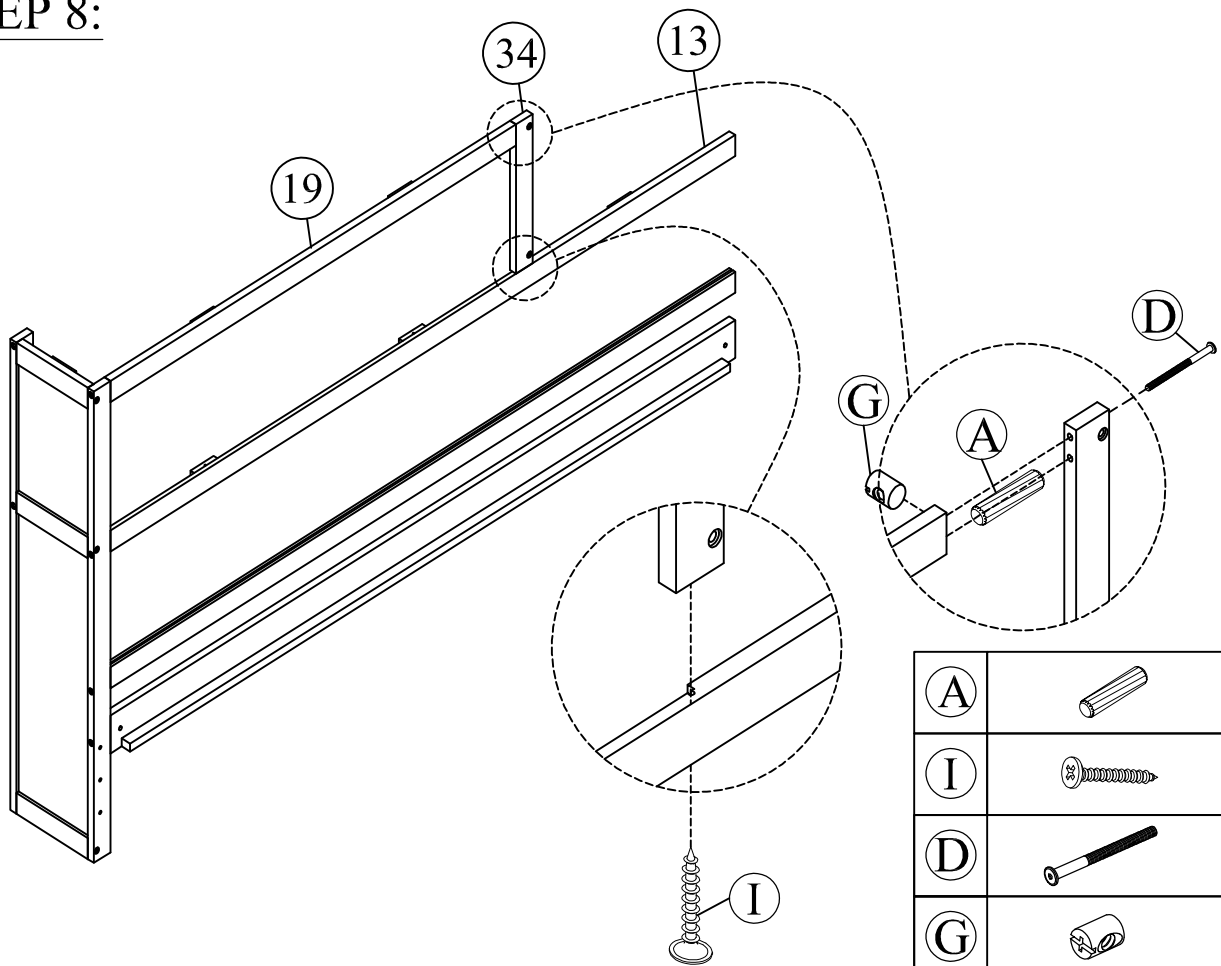

(A)		1pc
(I)		1pc
(D)		1pc
(G)		1pc

STEP 9:

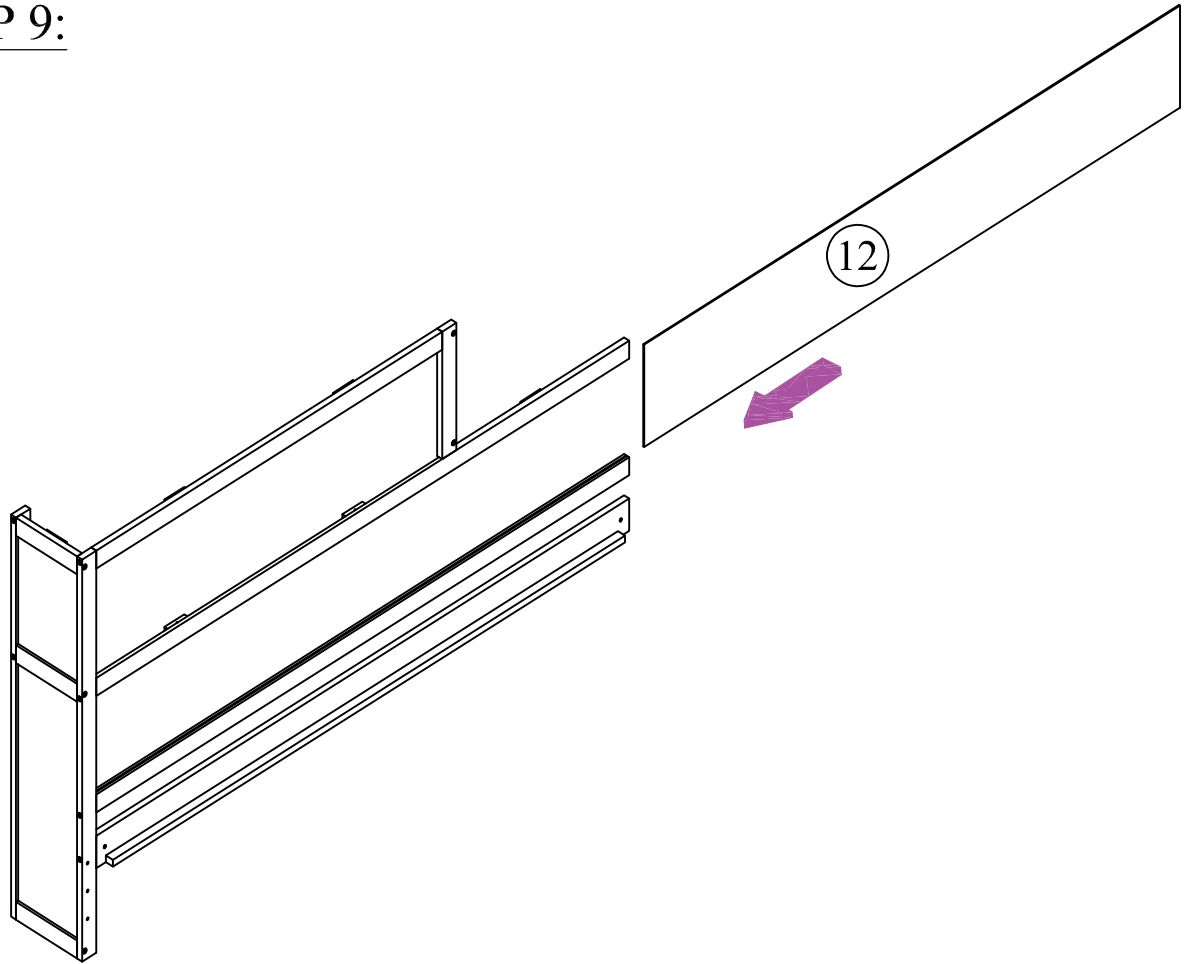

STEP 10:

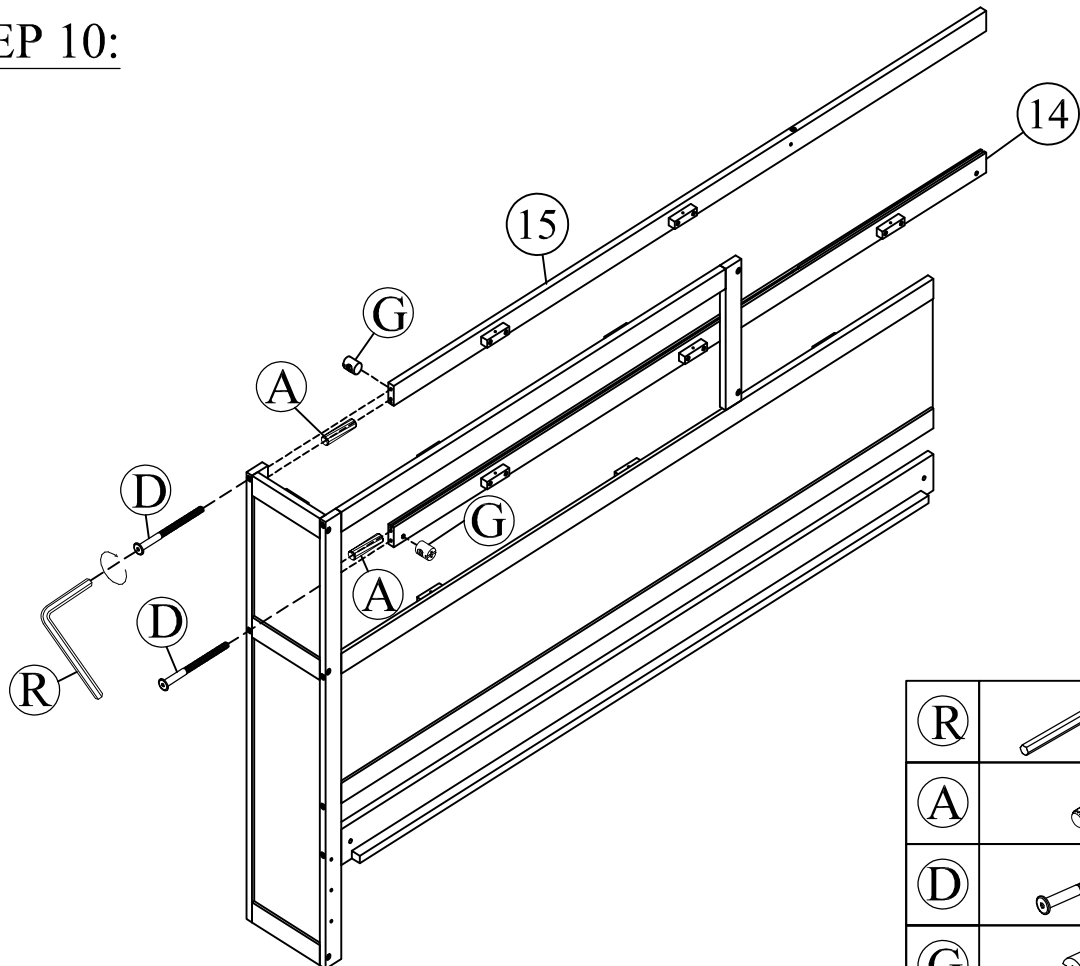

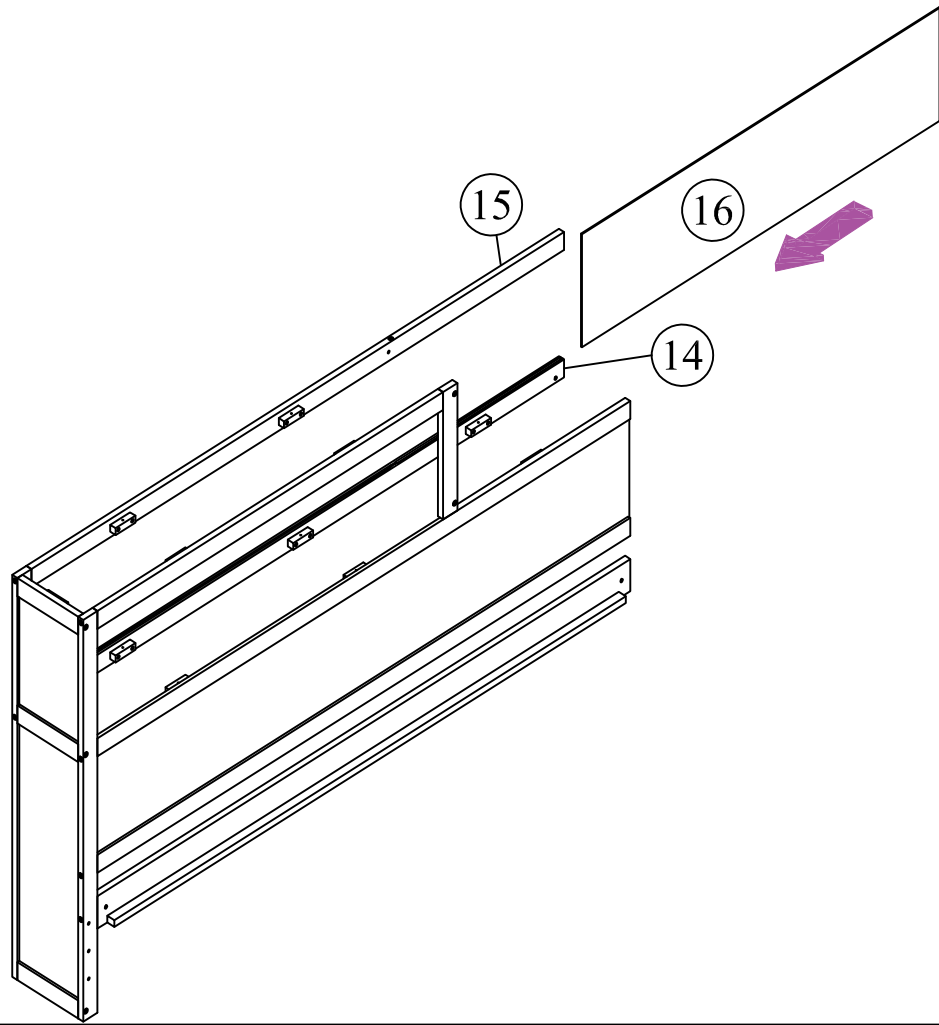

(R)		1pc
(A)		2pcs
(D)		2pcs
(G)		2pcs

STEP 11:

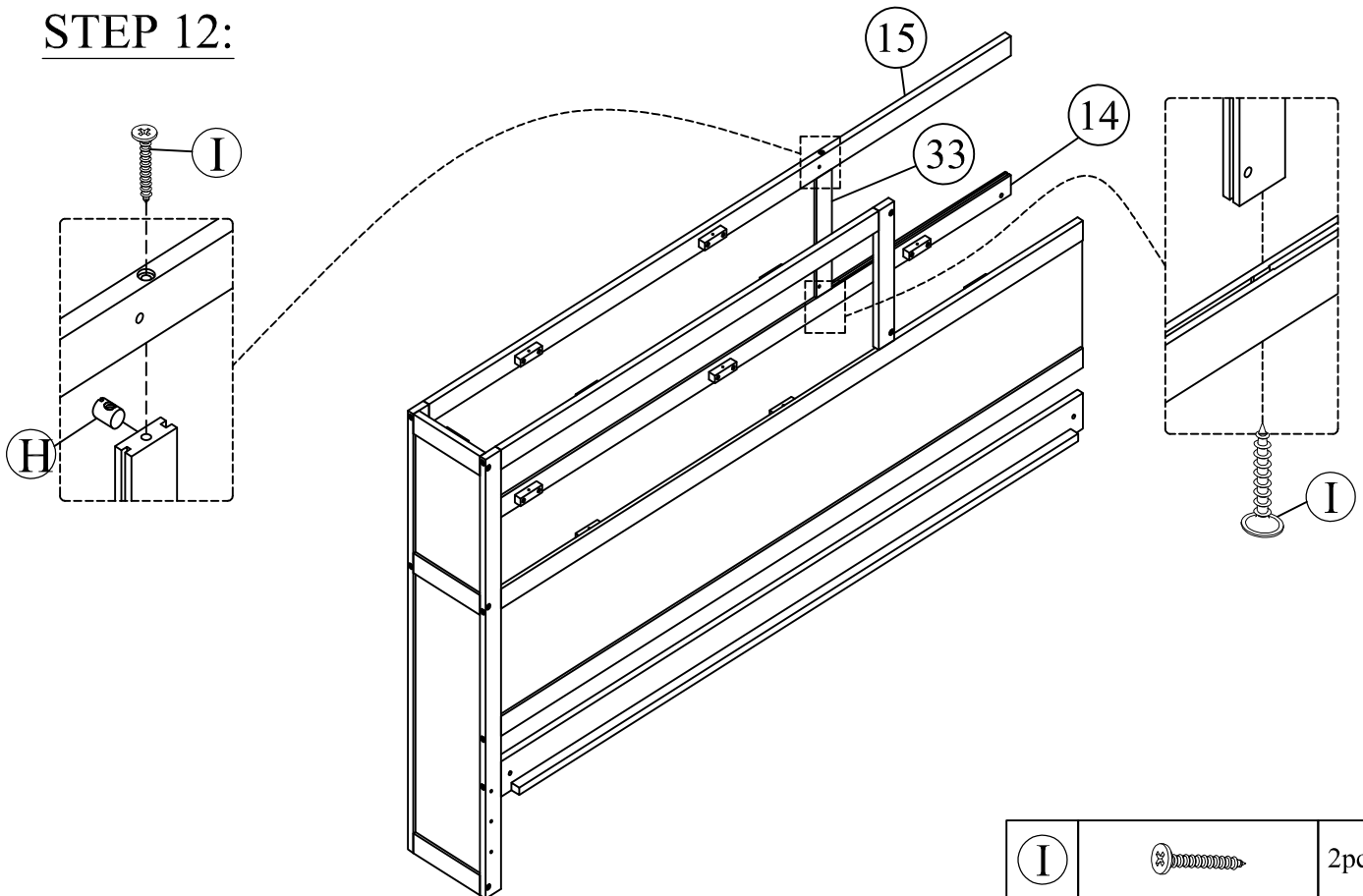

STEP 12:



I		2pcs
H		1pc

STEP 13:

I		3pcs
---	---	------

STEP 13.1:

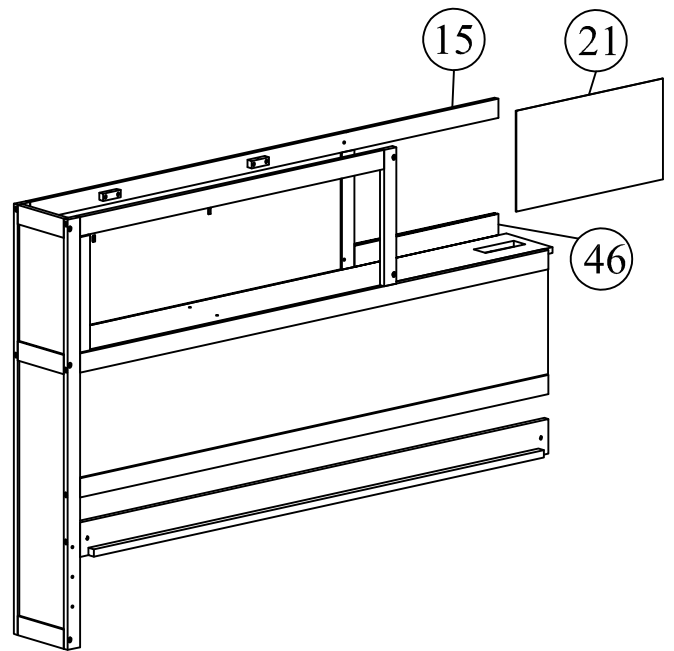
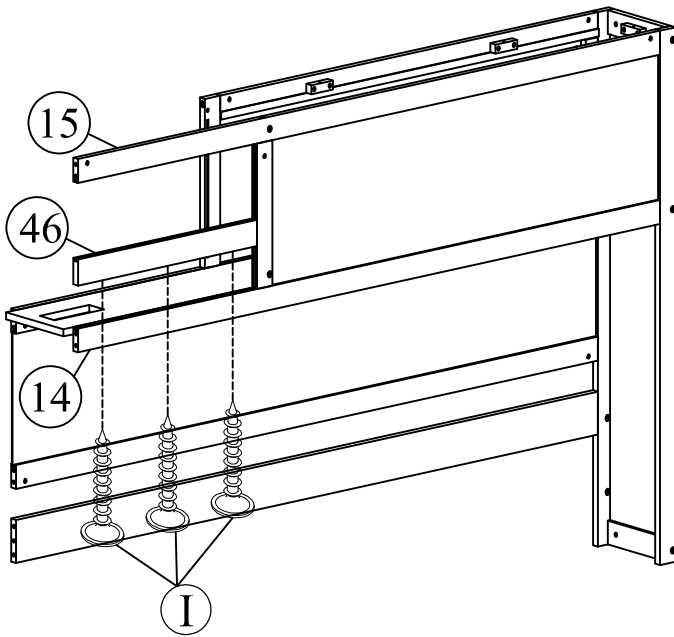



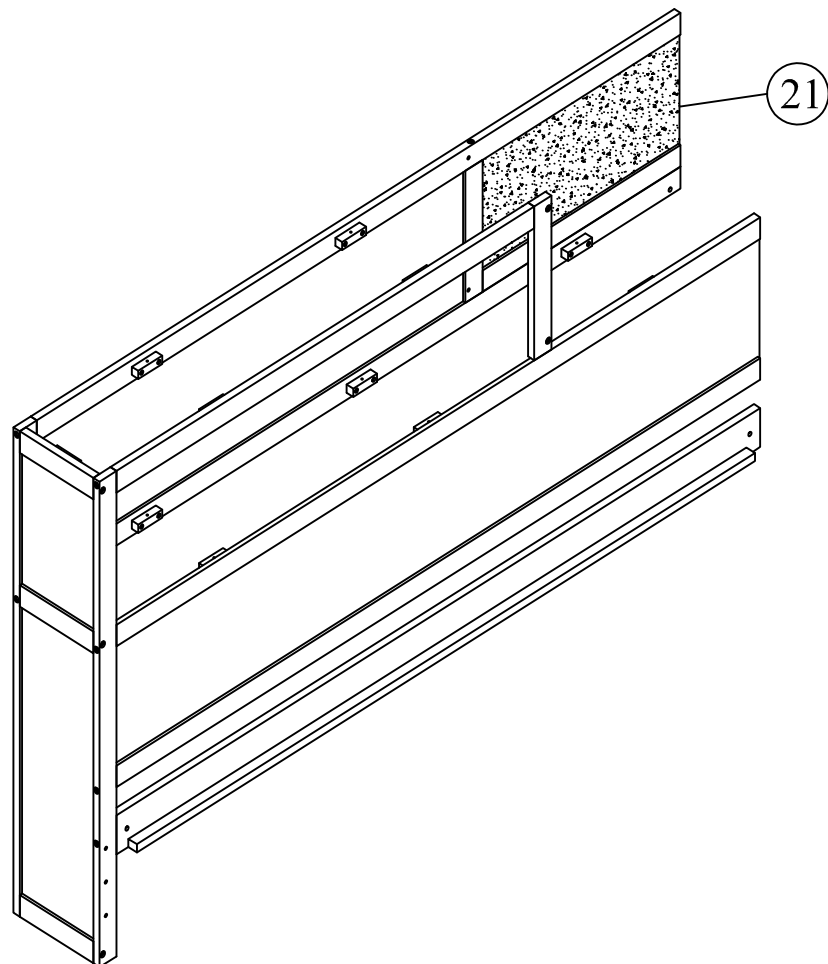

STEP 14:

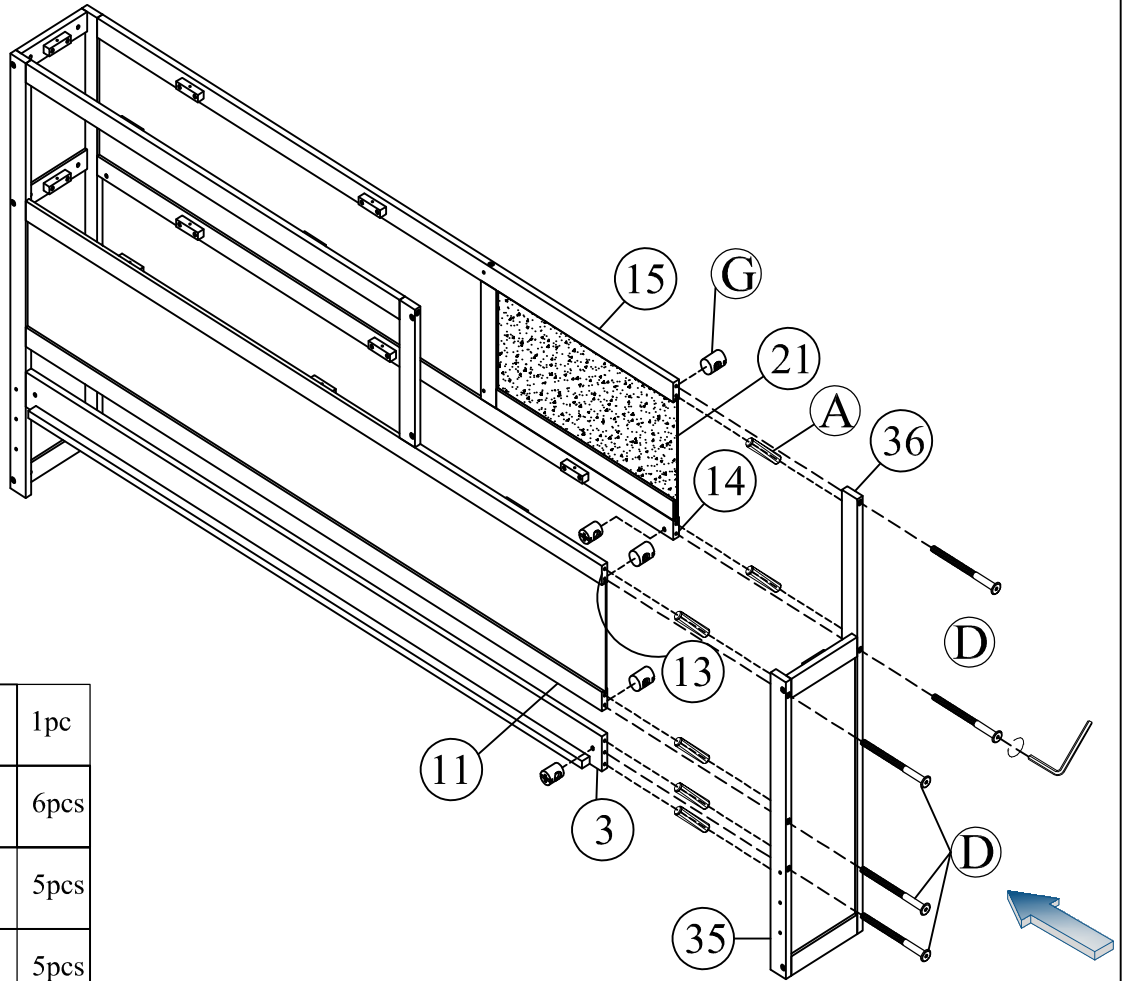

STEP 15:



(R)		1pc
(A)		6pcs
(D)		5pcs
(G)		5pcs

STEP 16:

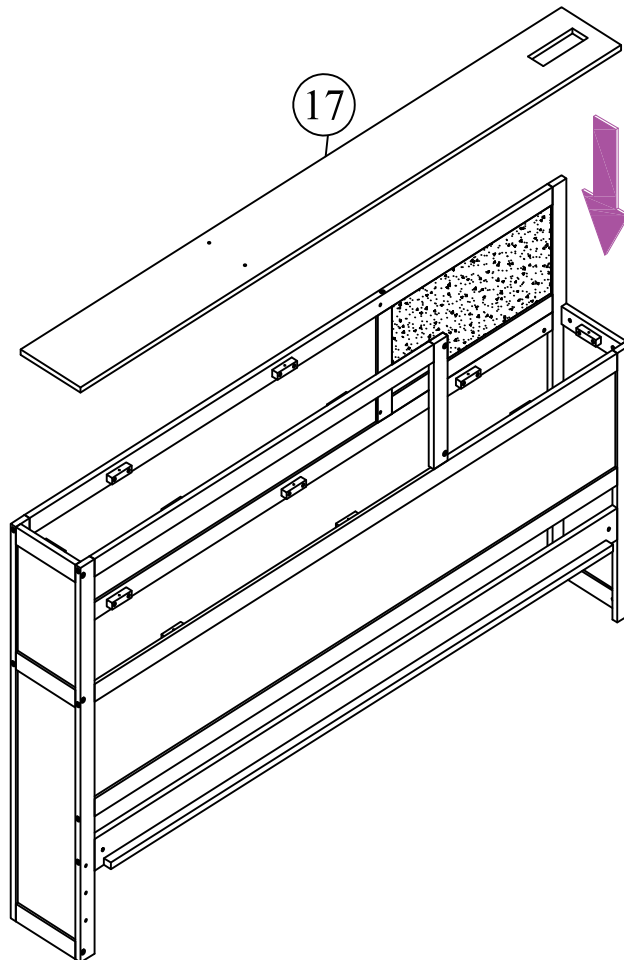

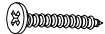

STEP 17:

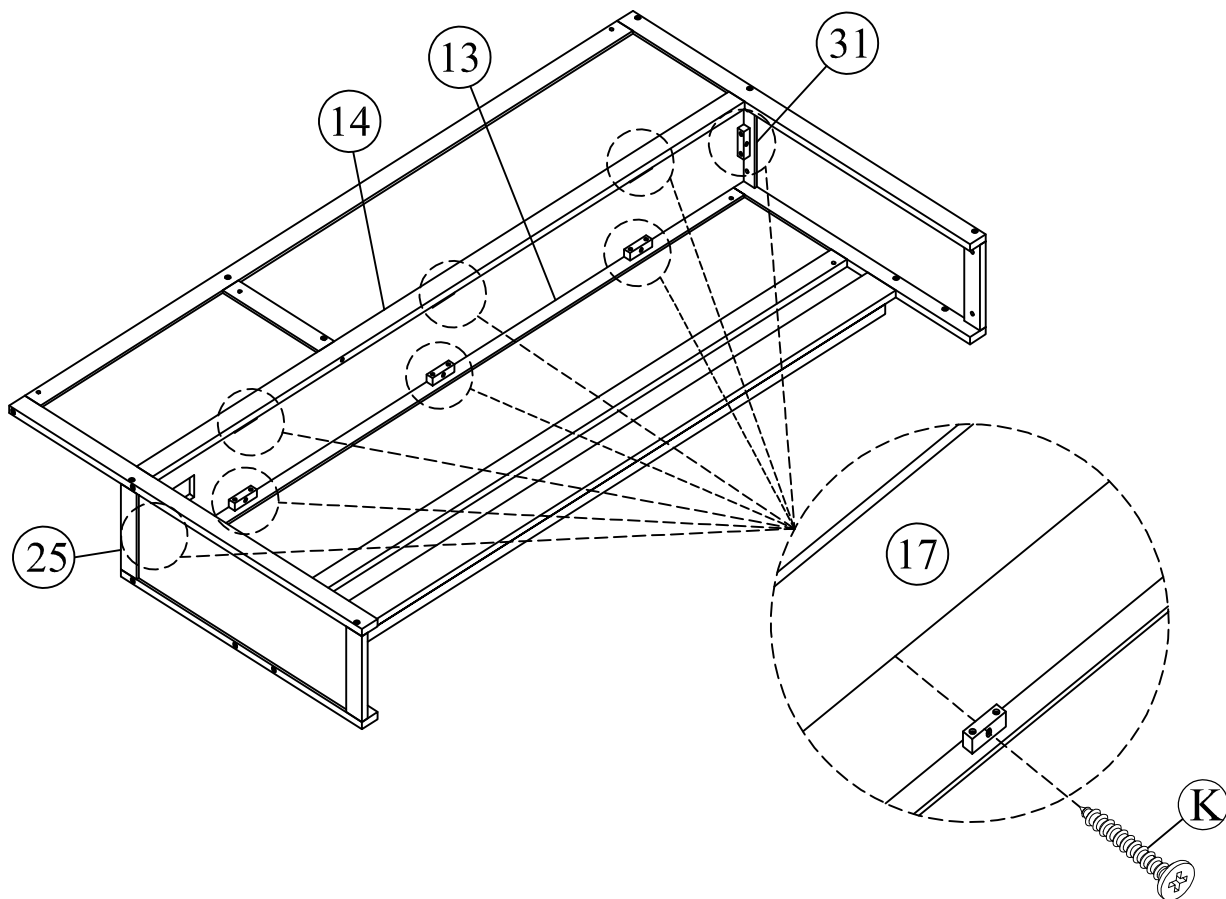
K		8pcs
---	---	------

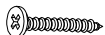

STEP 18:

I		2pcs
H		2pcs

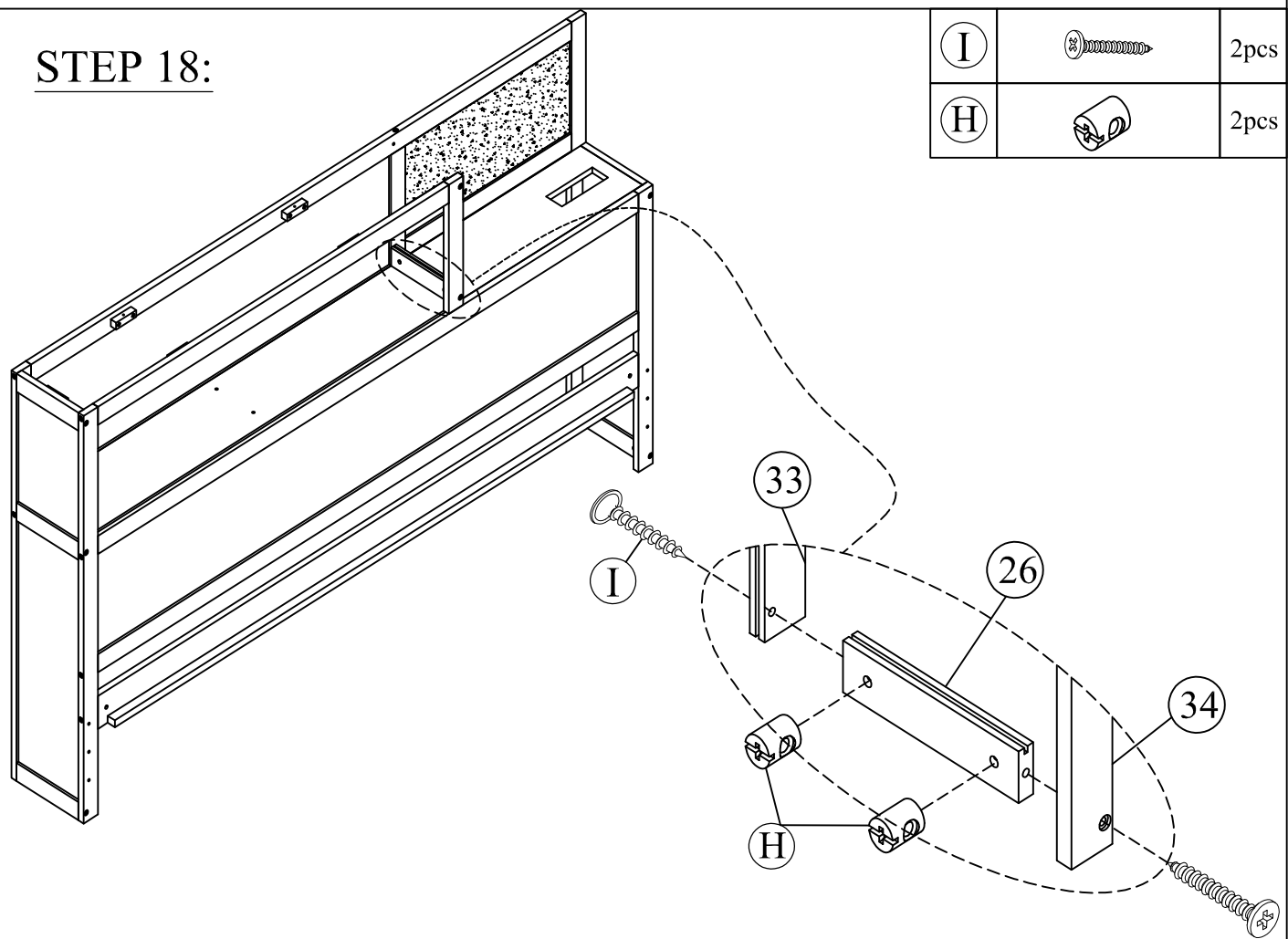

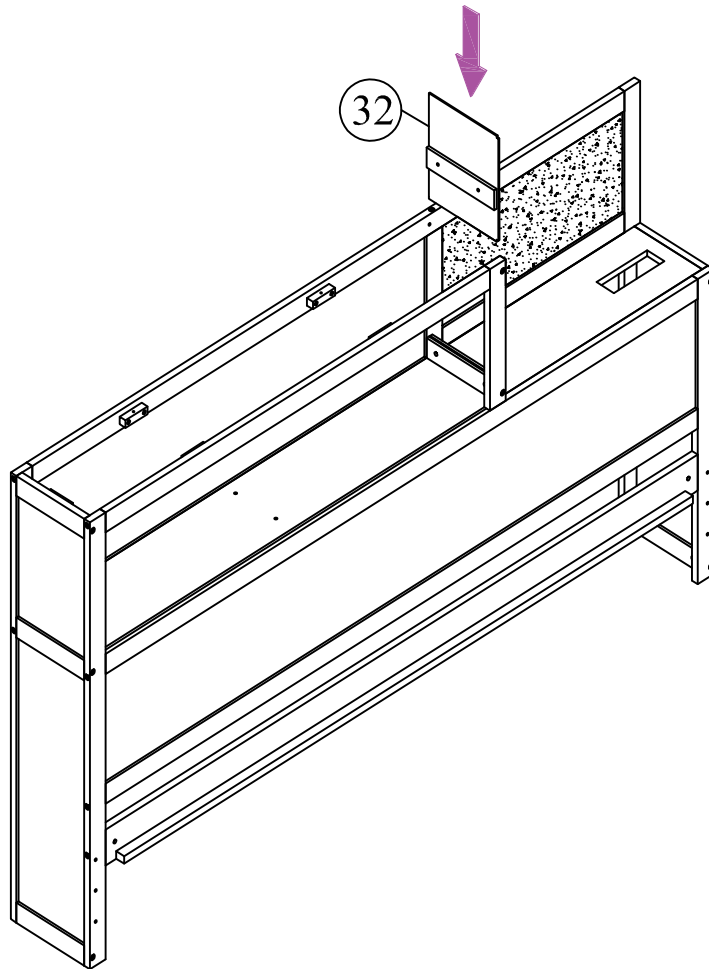

STEP 19:



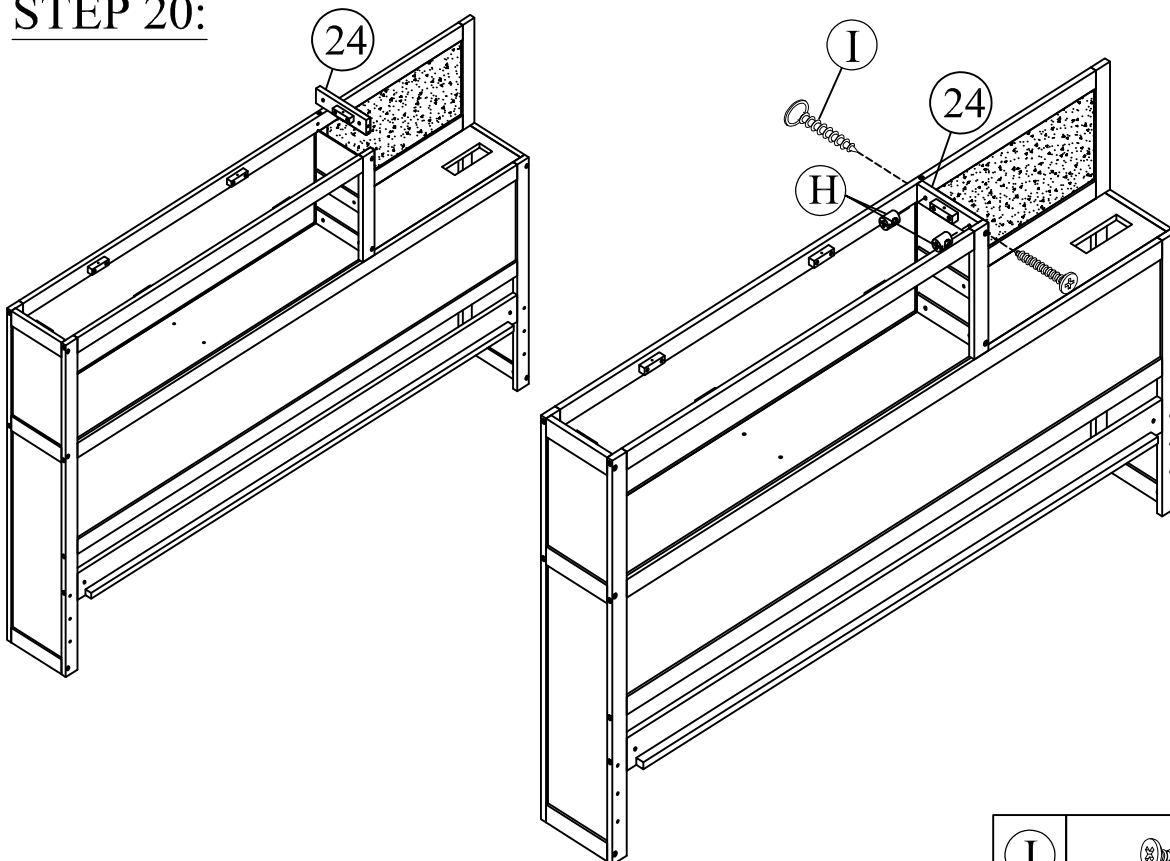

STEP 20:



I		2pcs
H		2pcs

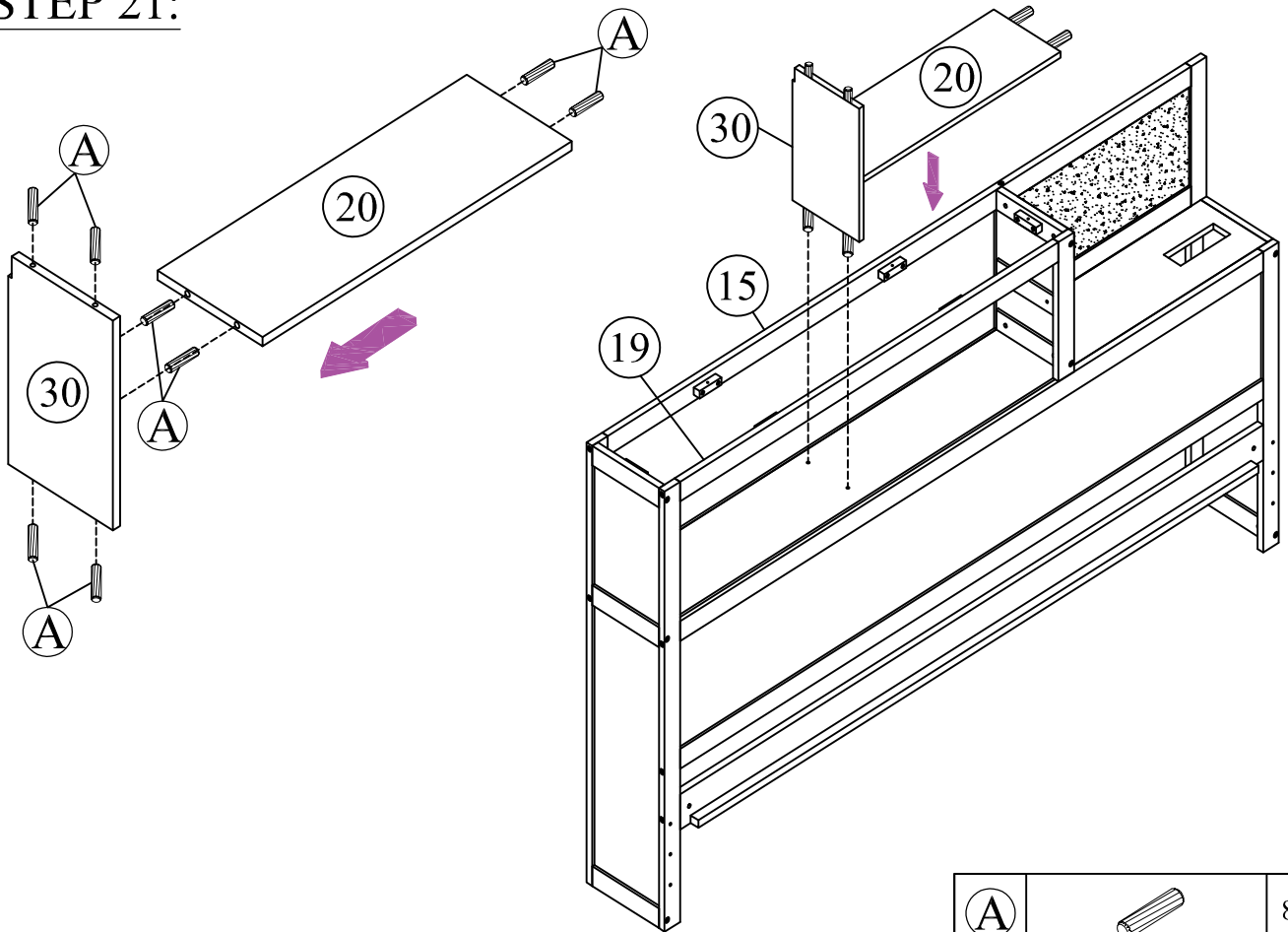

STEP 21:

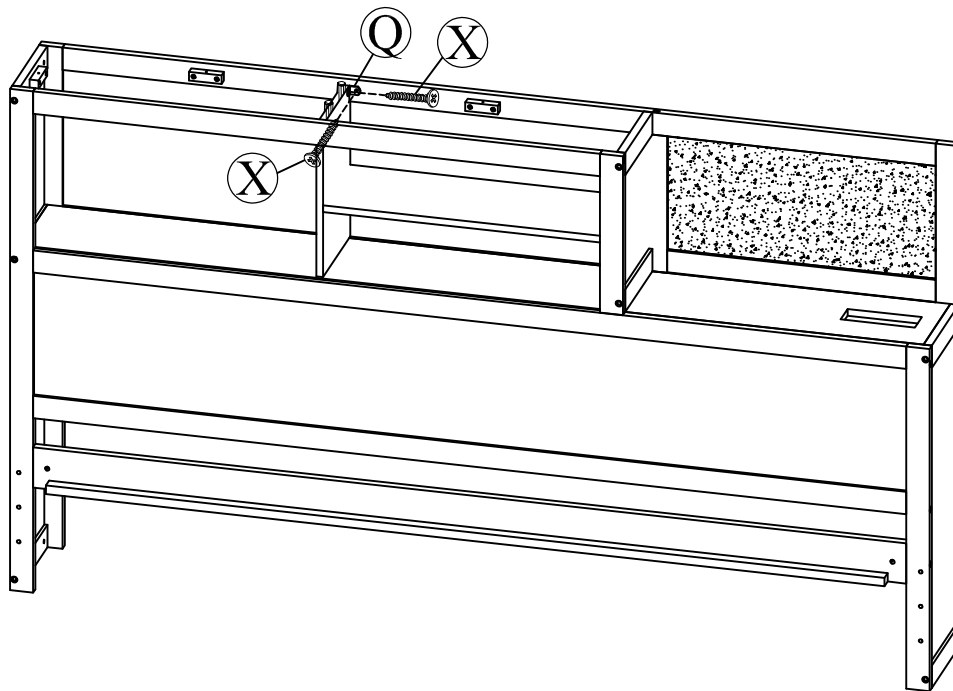

A		8pcs
---	---	------

STEP 22:



X		2pcs
Q		1pc

STEP 23:

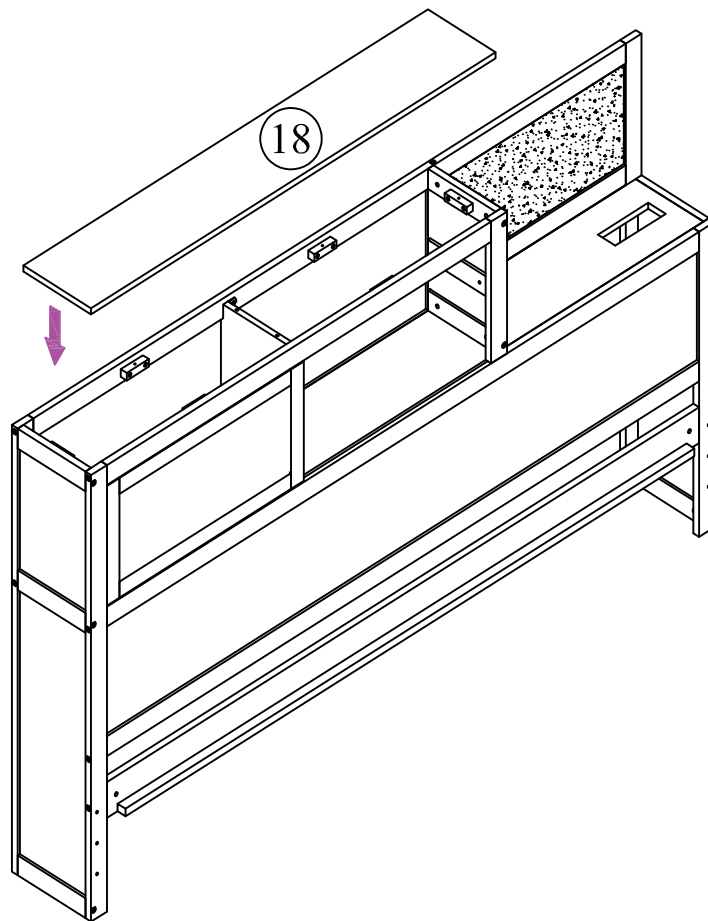

STEP 24:

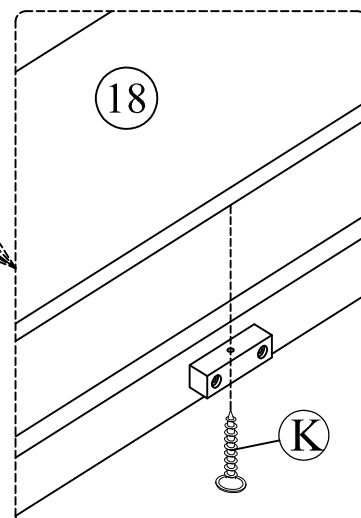
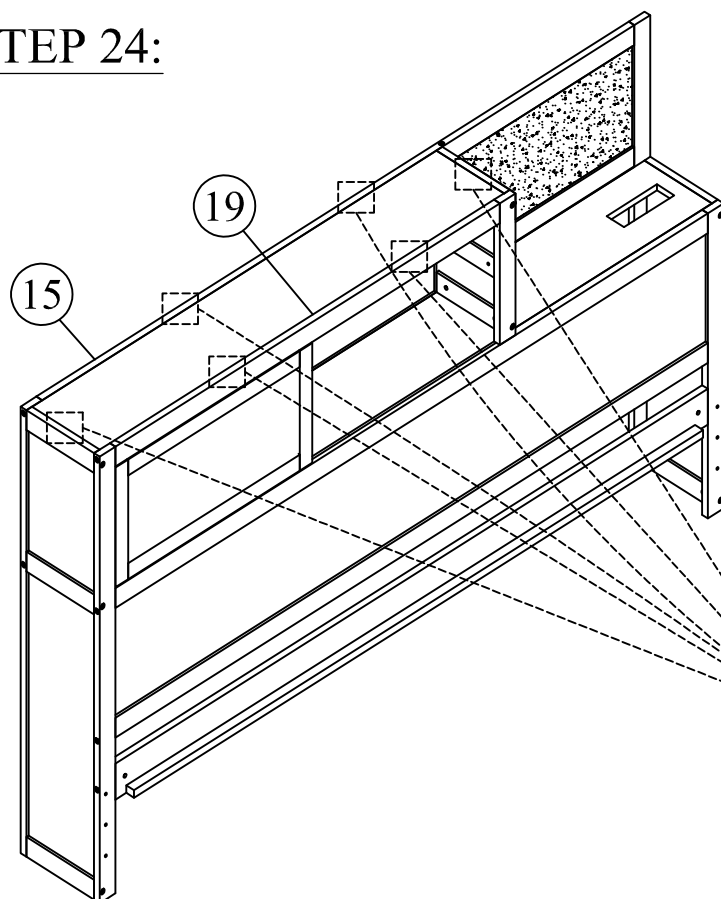
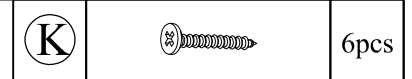

Note :
Lock the bolt.

STEP 25:

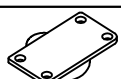
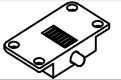
(M)		16pcs
(T)		2pcs
(U)		2pcs

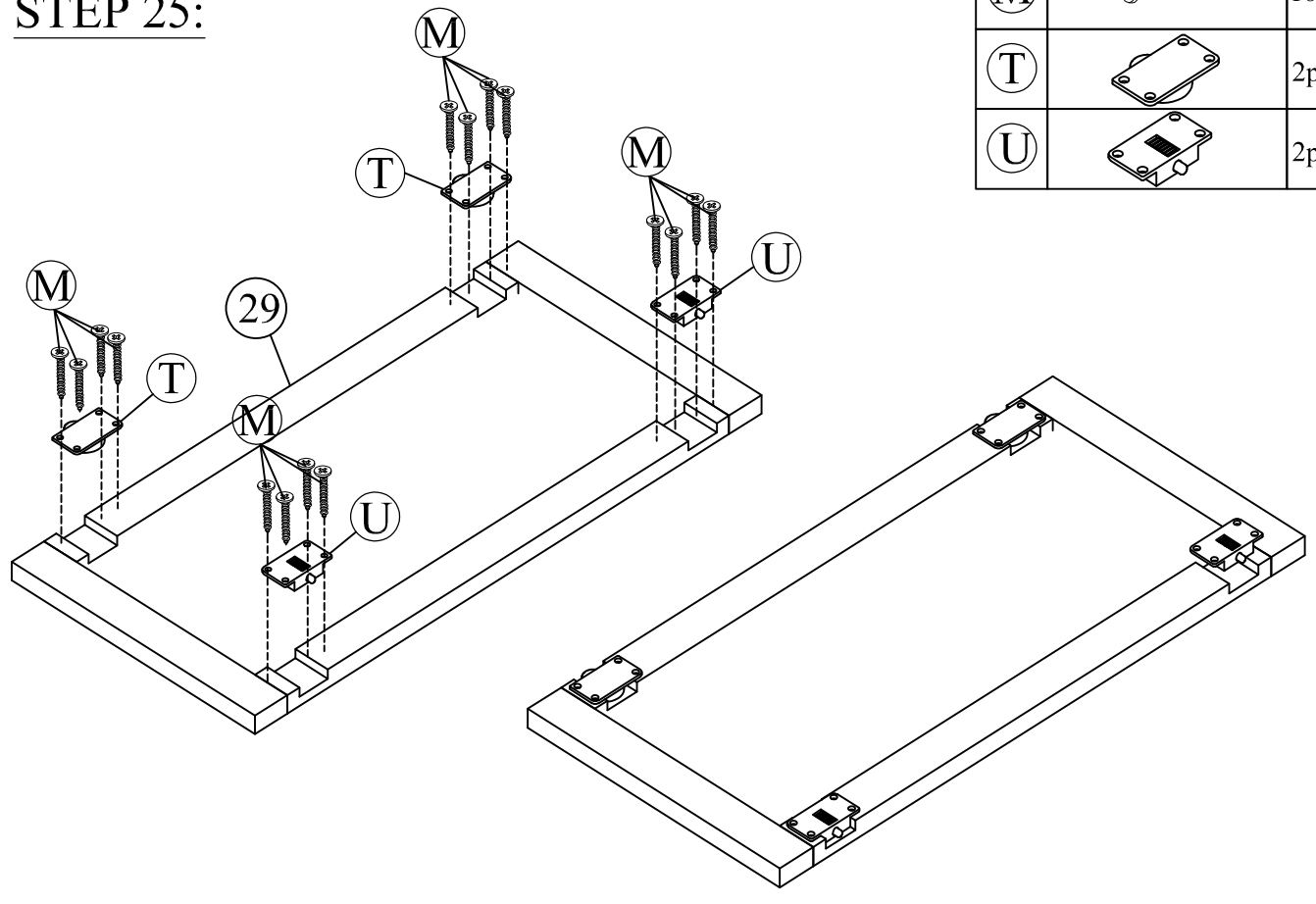

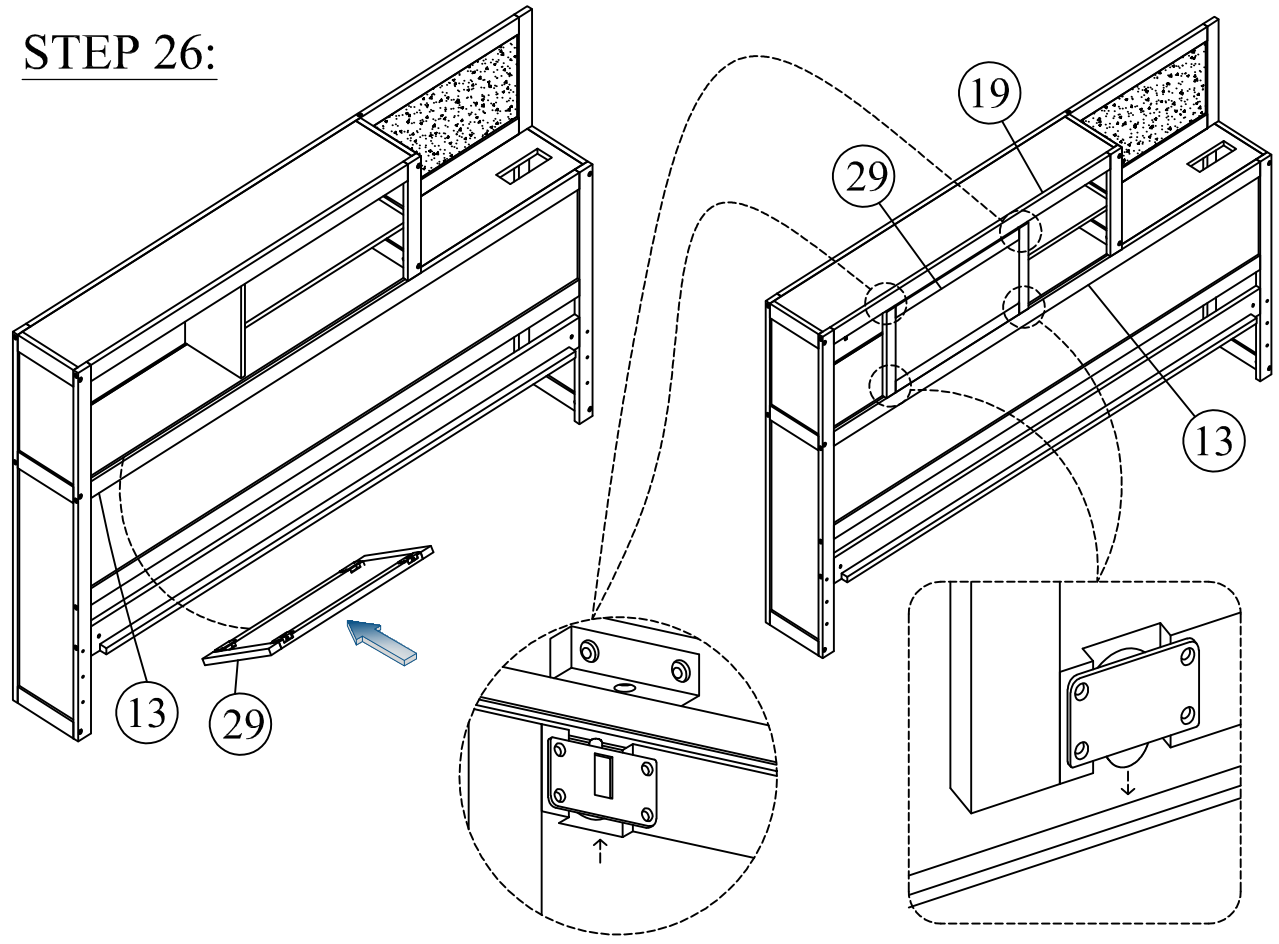

STEP 26:



Pull on the groove. The wheel need to run on the groove.

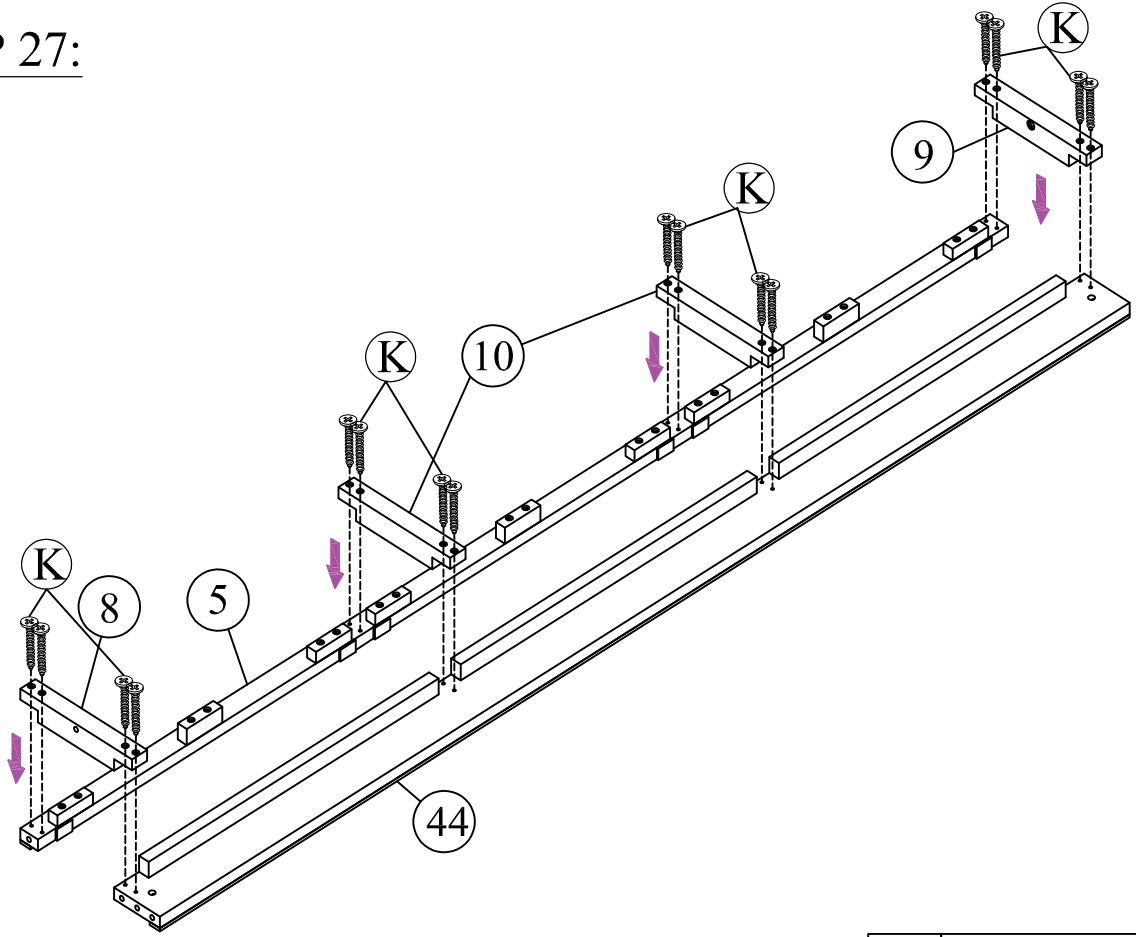



STEP 27:

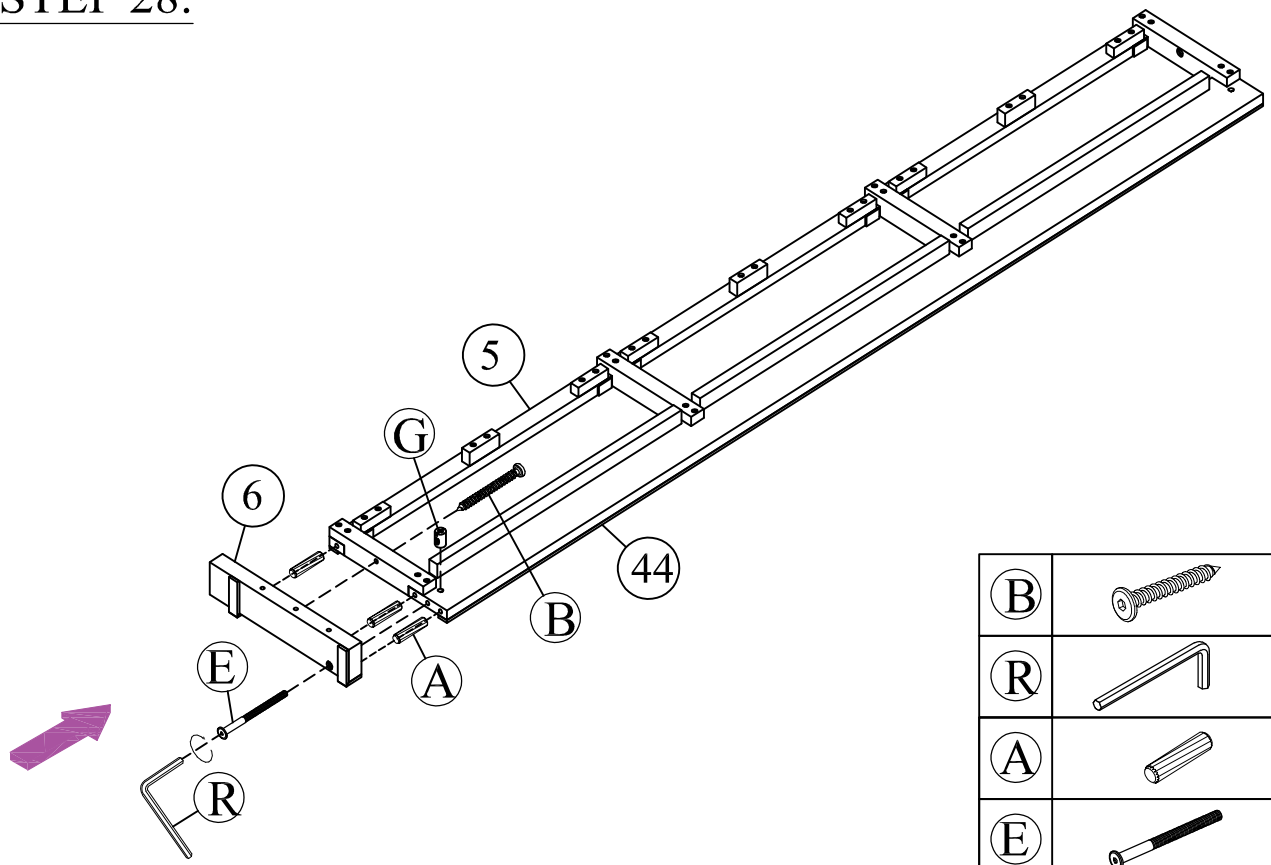

(K)		16pcs
-----	---	-------

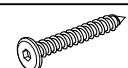



STEP 28:

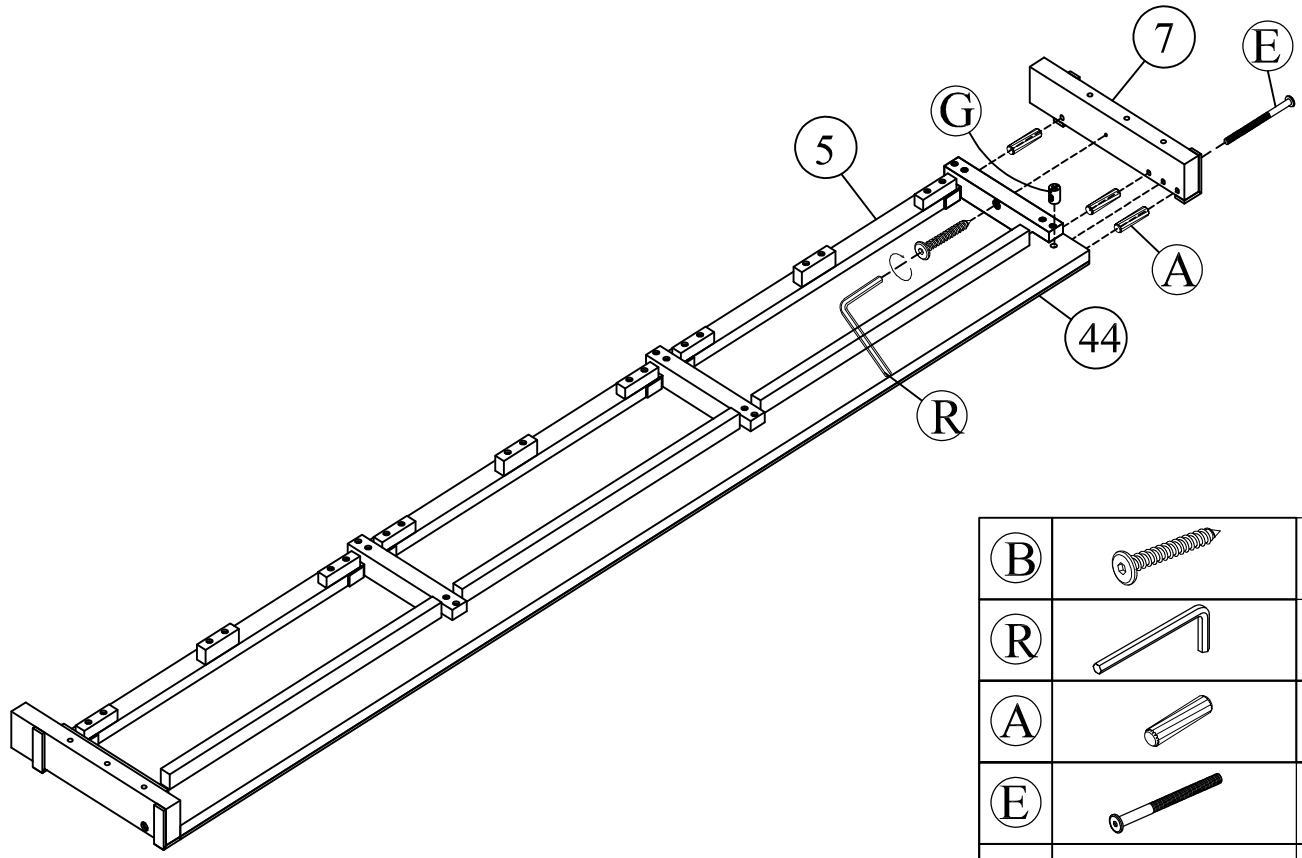

(B)		1pc
(R)		1pc
(A)		3pcs
(E)		1pc
(G)		1pc

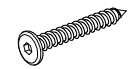



STEP 29:

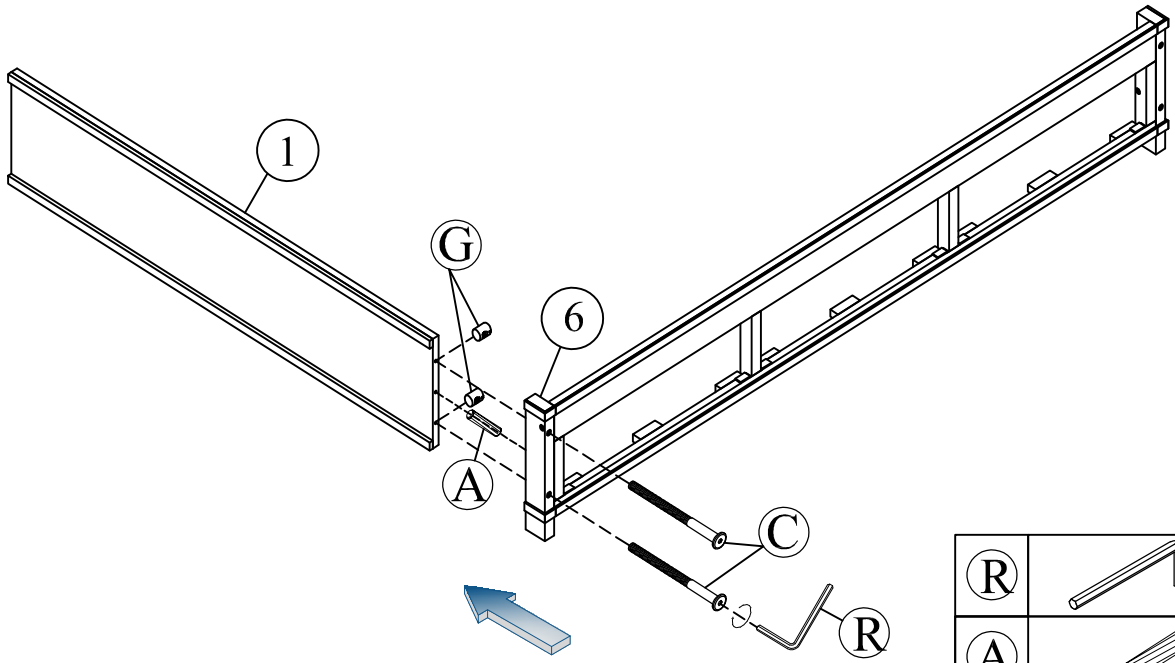

(B)		1pc
(R)		1pc
(A)		3pcs
(E)		1pc
(G)		1pc

STEP 30:



(R)		1pc
(A)		1pc
(C)		2pcs
(G)		2pcs



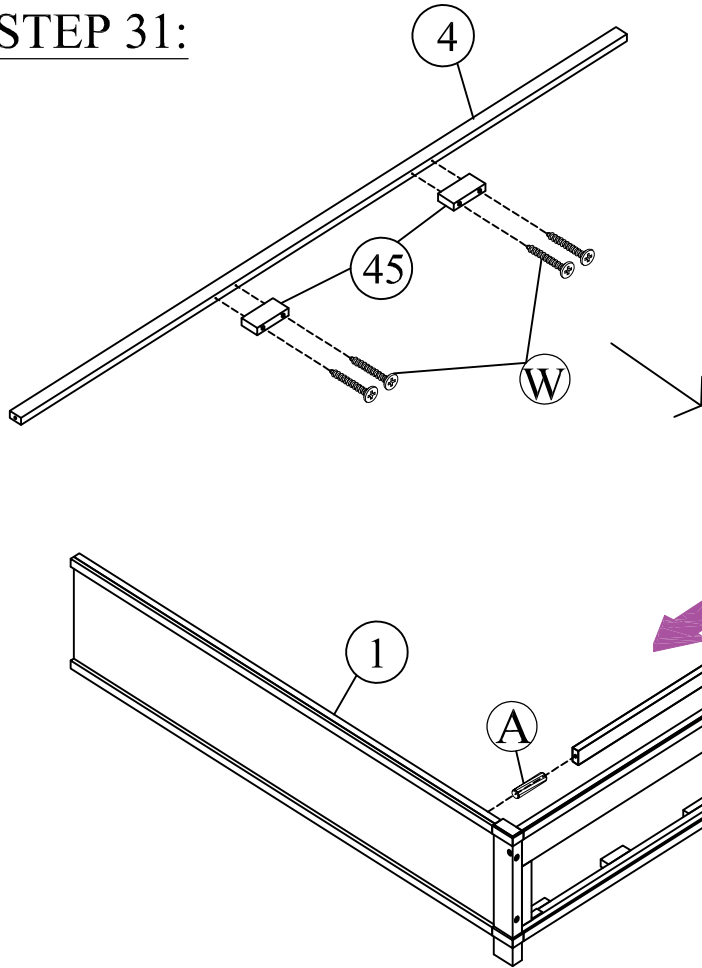

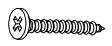
STEP 31:



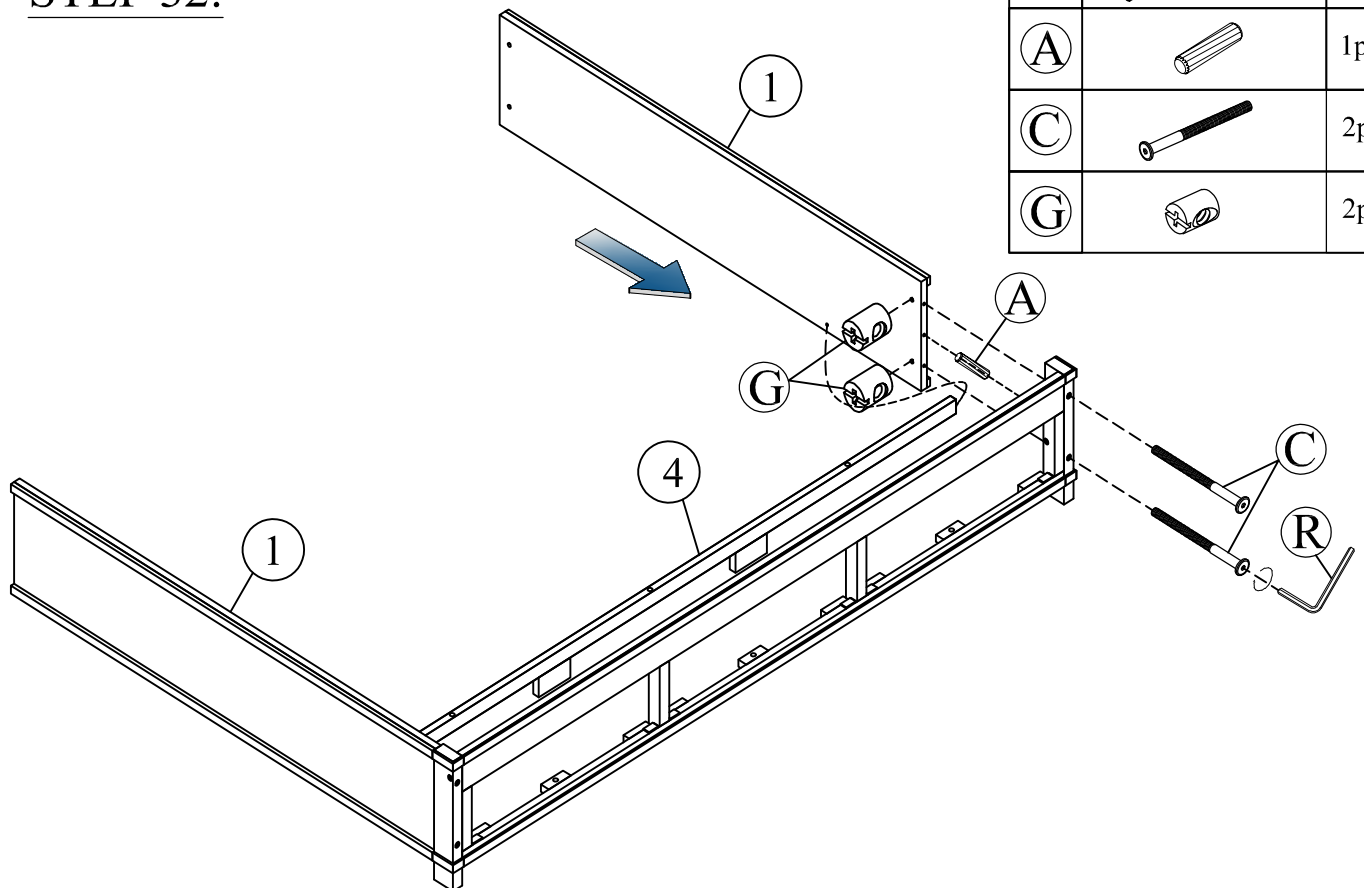



(A)		2pcs
(W)		4pcs

STEP 32:



(R)		1pc
(A)		1pc
(C)		2pcs
(G)		2pcs



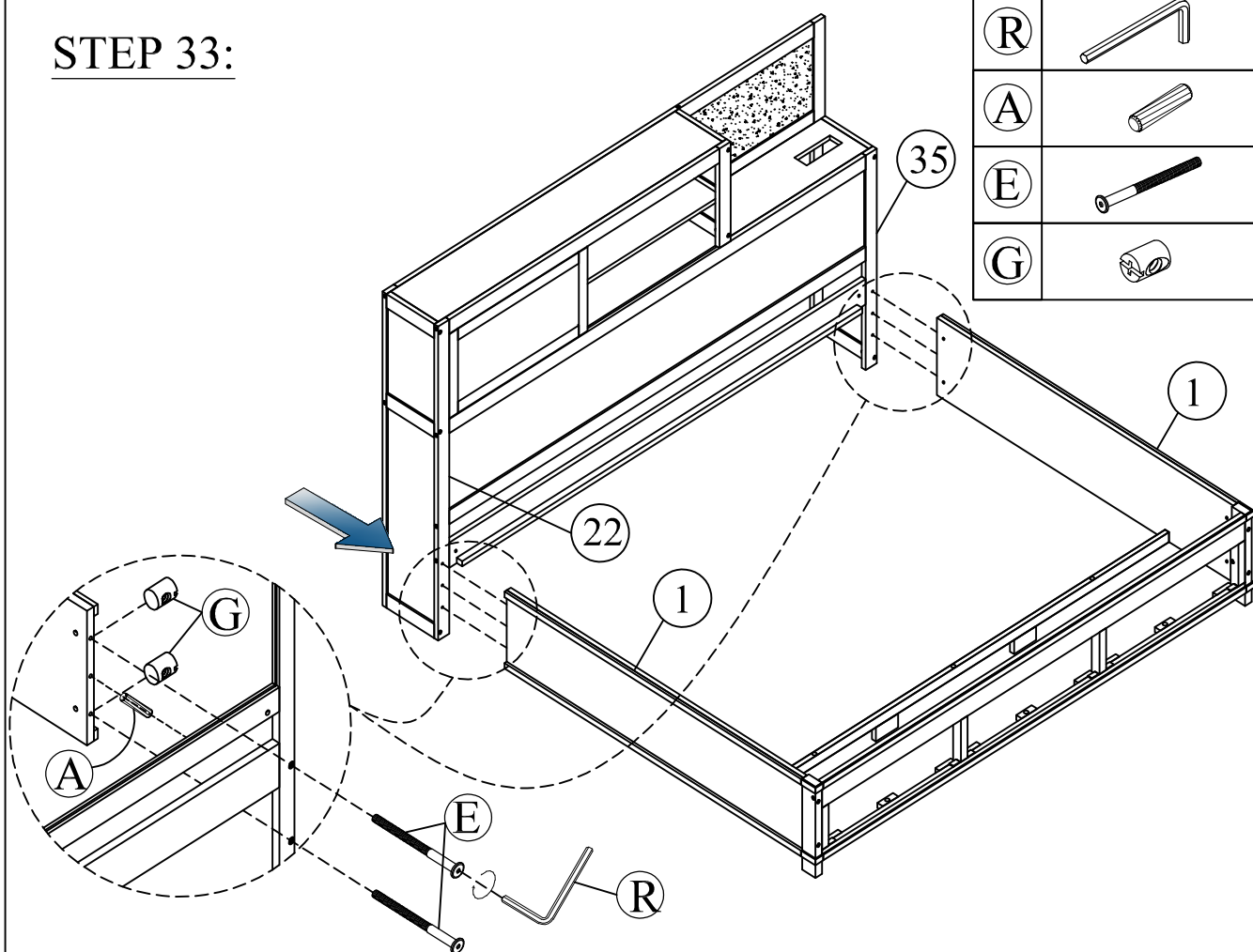

STEP 33:

(R)		1pc
(A)		2pcs
(E)		4pcs
(G)		4pcs

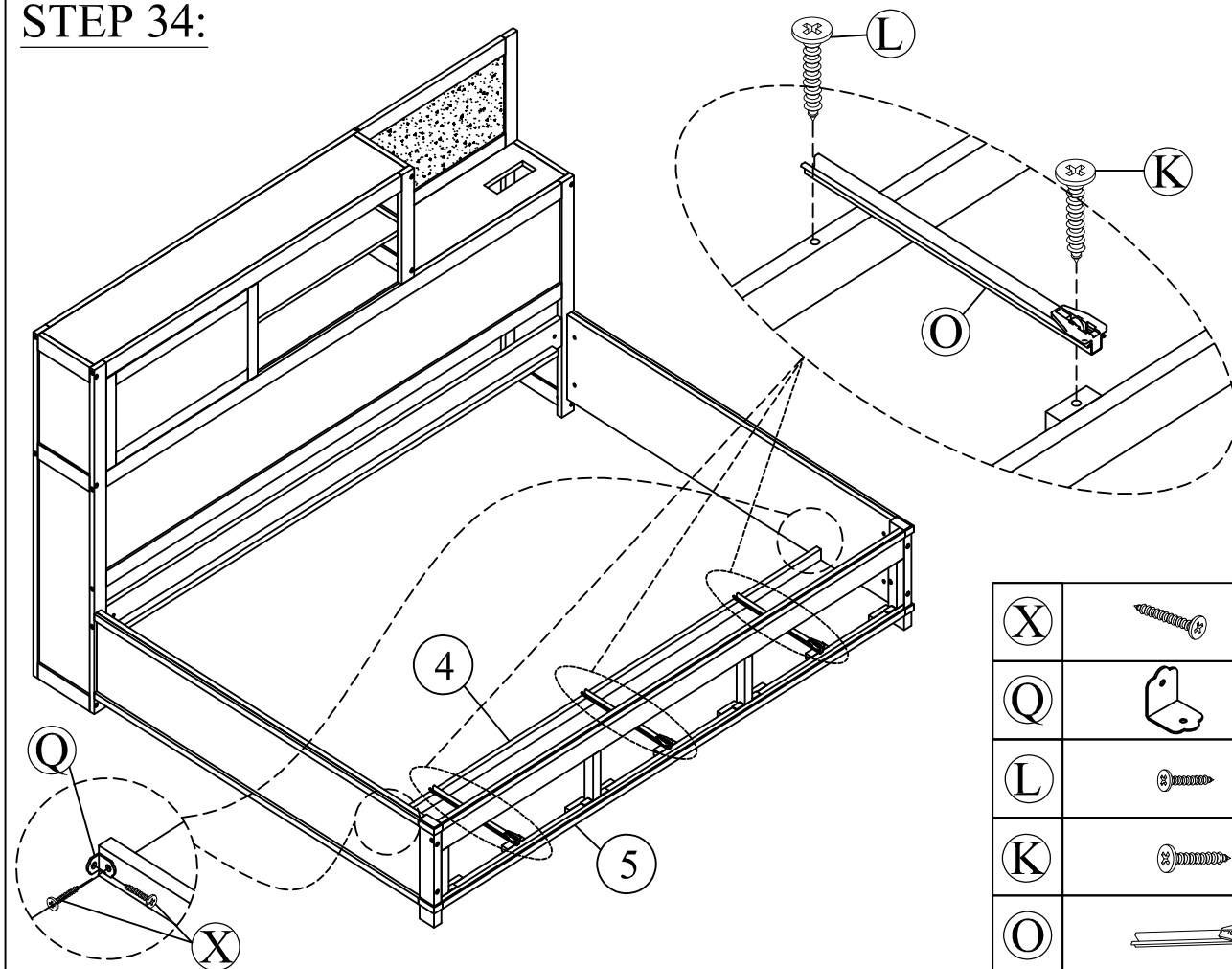

STEP 34:



(X)		4pcs
(Q)		2pcs
(L)		3pcs
(K)		3pcs
(O)		3pcs

STEP 35:

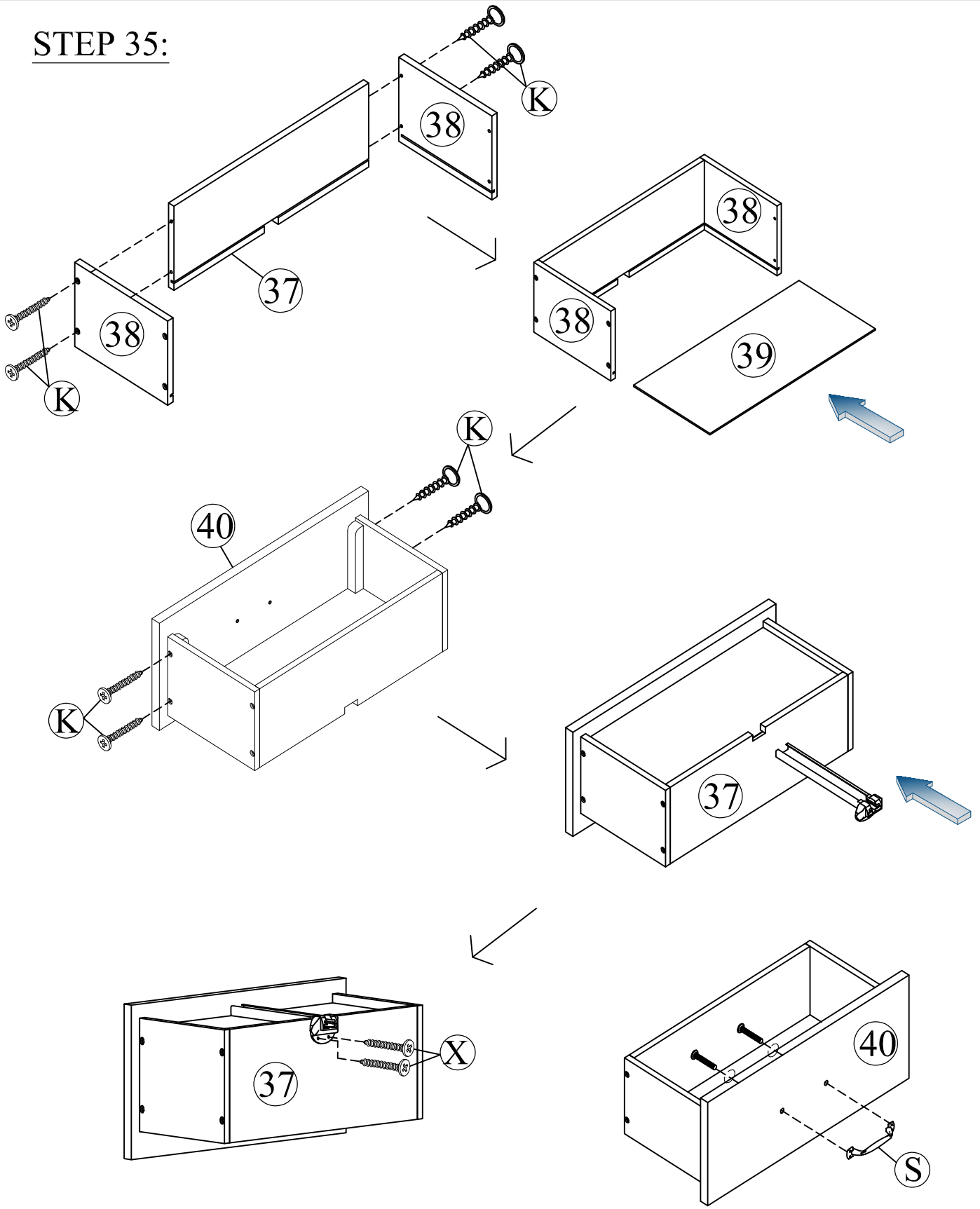

x3

(X)		6pcs
(K)		24pcs
(S)		3pcs
(N)		3pcs

STEP 36:

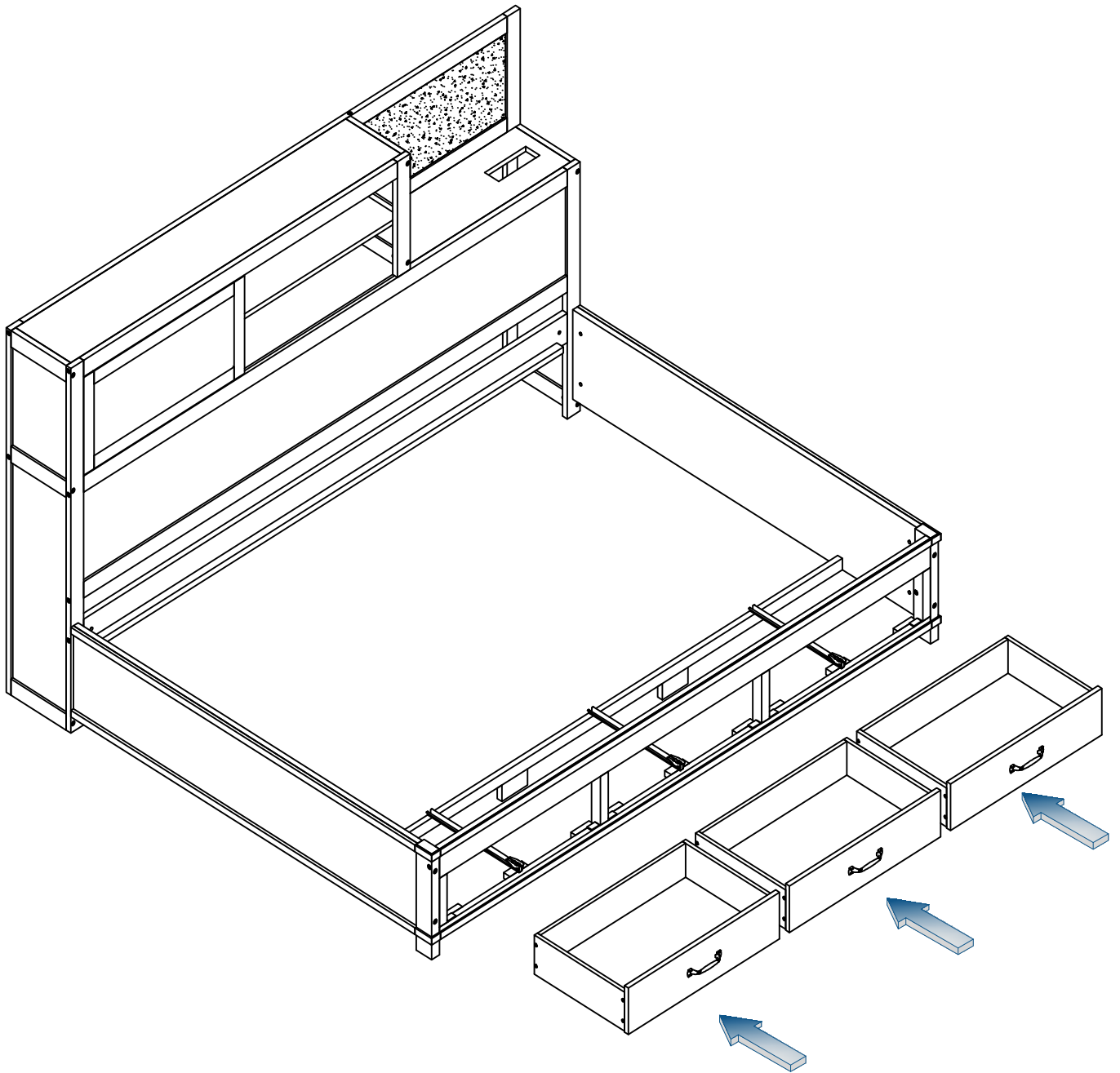

STEP 37:

J



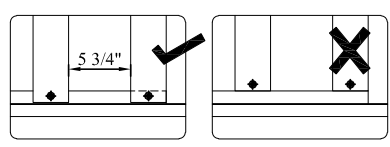
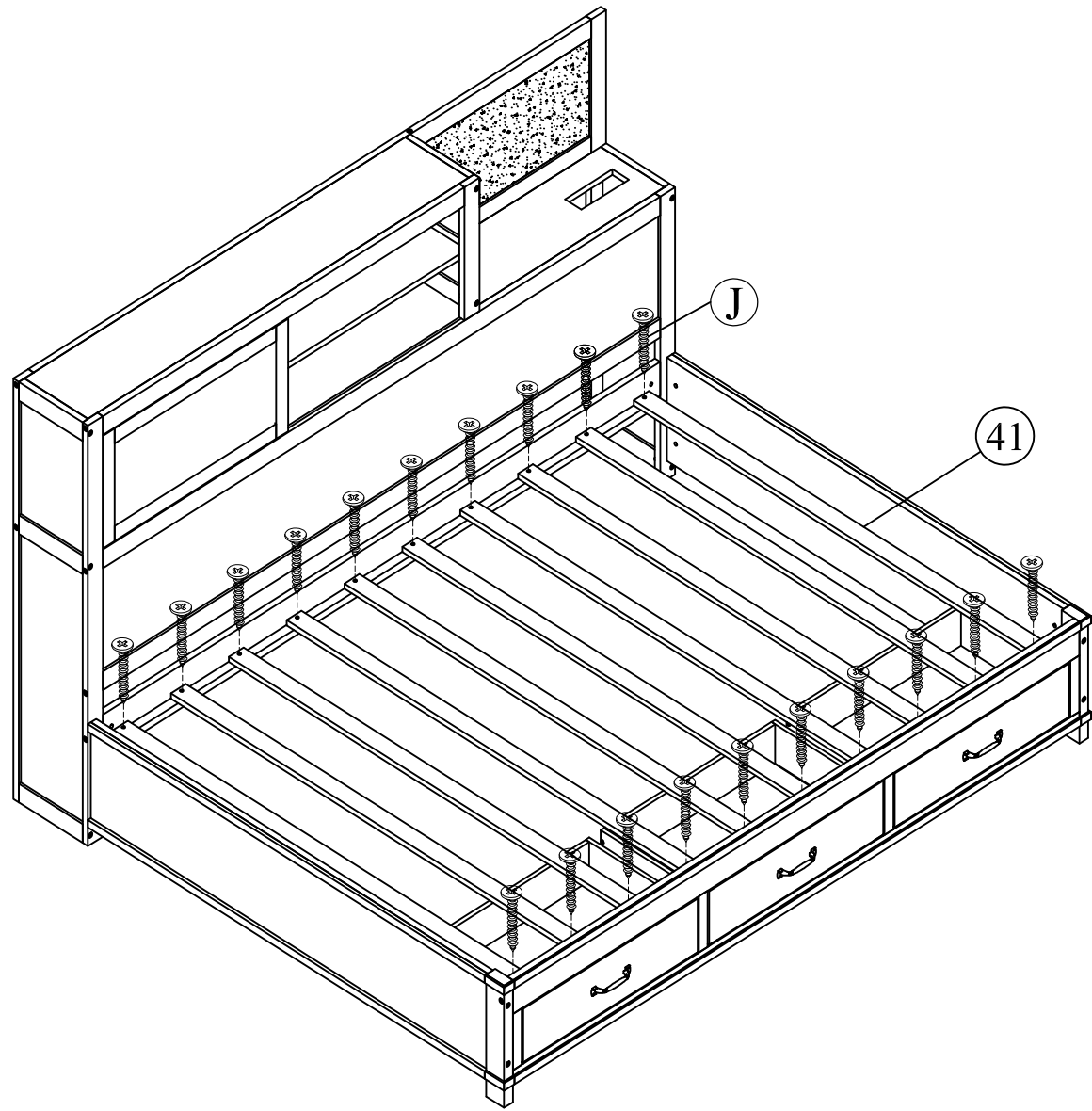

20pcs

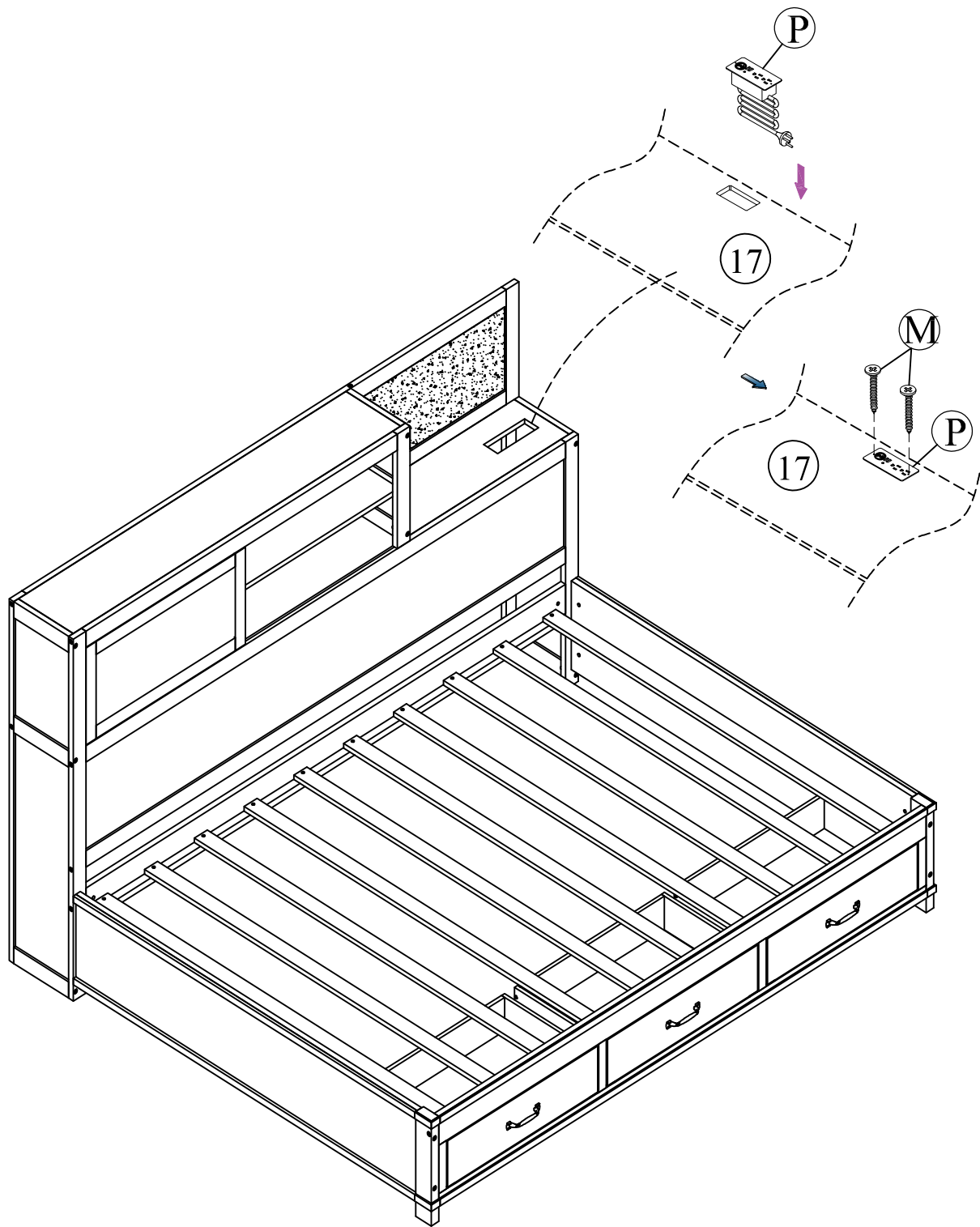

STEP 38:



P		1pc
M		2pcs

FINAL:

