









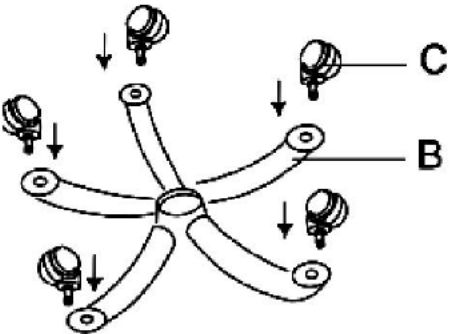
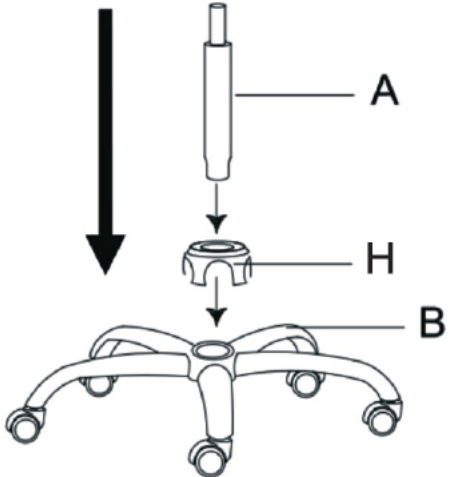

ASSEMBLY INSTRUCTIONS

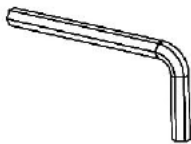
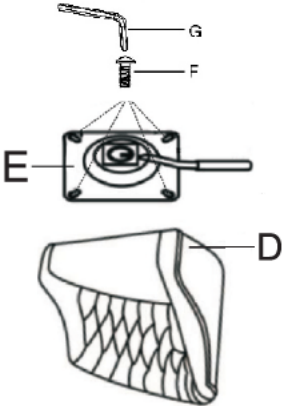
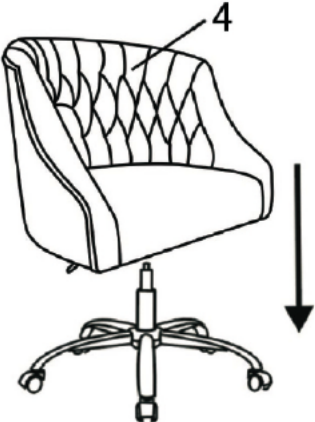
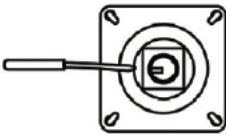
<p>A</p>  <p>1 PC</p>	<p>F</p>  <p>4 PCS</p>	<p>STEP 1 Insert caster C to bottom of the spider base B.</p> 	<p>STEP 2 Attach the metal cover H on top of the base then insert the gas lift to the center hole of the base.</p> 
<p>B</p>  <p>1 PC</p>	<p>G</p>  <p>1 PC</p>		
<p>C</p>  <p>5 PCS</p>	<p>H</p>  <p>1 PC</p>	<p>STEP 3 Do not fully tighten the bolts until all the bolt align with the hole. Pls be sure you align the hole first.</p>  <p>Use bolt F and allen key G to attach mechanism E to bottom of the seat,make sure the holes on under seat align with metal plate,then fasten bolts to secure.</p>	<p>STEP 4 Assembly completed.</p>  <p>Be sure to check all packing material carefully for small parts, which may have come loose inside the carton during shipment.</p> 
<p>D</p>  <p>1PC</p>	<p>I EXTRA PARTS</p>  <p>1PC</p>		
<p>E</p>  <p>1PC</p>			