

















CARE AND MAINTENANCE

Wipe clean with a soft, dry cloth. The seat board can be cleaned with a mild cleaner. Test the cleaning method on a hidden area before using them over the entire area.

NOTICE

- * Please make sure that you have all parts indicated before you begin assembly of this item.
- * This item should be assembled on a soft surface to prevent scratching the finished product during assembly.
- * This item may require periodic tightening.
- * Do not tighten bolts until completely assembled.

Part List and Hardware List

Piece	Description	Picture	Quantity
A	HEADBOARD		1X
B	L-POST		1X
C	R-POST		1X
D	FOOTBOARD		1X
E	SUPPORT LEGS OF SLATS		8X
F	SUPPORT LEGS OF RAILS		2X
G	SLAT		4X
H	L-RAIL		2X
I	R-RAIL		2X
J	WOOD LEG		2X
K	WOOD BAR		2X
H1	BOLT 5/16"*2-1/2"		12X
H2	BOLT 1/4"*2"		10X
H3	ALLEN KEY 4mm		1X
H4	SCREW Ø8*30mm		8X
H5	SCREW Ø8*15mm		8X
H6	METAL PLATE 50*33*1mm		2X

Product Dimensions:82-1/4"W*58-1/4"D*54-1/4"H

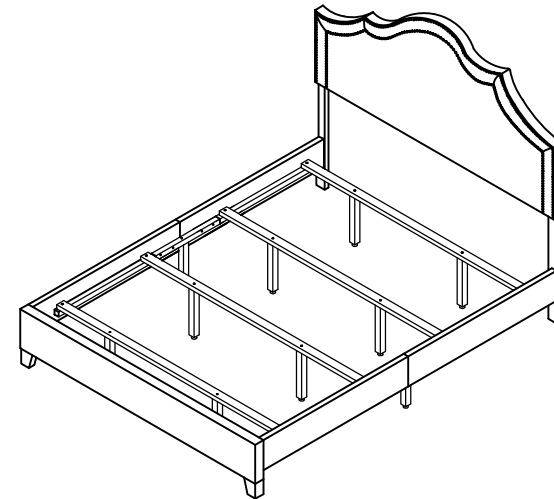

Weight capacity : 550lbs

WARNING : DO NOT STAND ON THE BED

