

NOTICE

- * Please make sure that you have all parts indicated and they are in good condition before you begin assembly of this item. Refer to part list and hardware list below for guidance.
- * This item should be assembled on a soft surface to prevent scratching the finish during assembly.
- * This item may require periodic tightening.
- * If you are having difficulty, our friendly Customer Care team is always here to help. Please email customersupport@safavieh.com







PREPARATION

- * Before beginning assembly of product, make sure all parts are present. Compare parts with part contents list and hardware contents list.
- * If any part is missing or damaged, do not attempt to assemble the product.
- * Estimated Assembly Time: 10 minutes.
- * Tools Required for Assembly (Included): Allen Key
- * Tools Required for Assembly (Not Included): Screw Driver

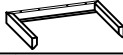
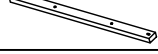
CARE AND MAINTENANCE

Adhesive felt pads should always be applied to areas of furniture which make direct contact with flooring, said application will prevent damage to the furniture and or surfaces on which the furniture lies. Object placed on articles of furniture should rest on non abrasive material as to prevent damage to the wood finish. Objects whose composition consists of plastic and rubber are known to discolor and damage the wood surfaces on which they rest. Wipe up spills immediately and avoid common hazards such as hot dishes, harsh solvents and abrasives. Cleaning should be done with a soft lint free cotton cloth dampened with water or furniture polish. On highly used surfaces we recommend applying a quality paste wax which should be used on a regular basis to provide additional protection from scratches and spills. How often you apply the wax depends on how much wear the furniture receives.

Part List and Hardware List

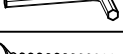
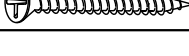
PIECE	DESCRIPTION	PICTURE	QUANTITY	Carton Call
A	TABLE TOP		1x	1 of 2
B	TABLE LEG		2x	2 of 2
C	SUPPORT LEG		2x	2 of 2
HW1	M8 x 50MM JCBB BOLT		8x	1 of 2
HW2	M6 x 50MM JCBC BOLT		4x	1 of 2
HW3	SPLIT WASHER M8 x 8.5MM		8x	1 of 2
HW4	SPLIT WASHER M6 x 6.5MM		4x	1 of 2
HW5	FLAT WASHER M8 x 8.5MM		8x	1 of 2
HW6	ALLEN KEY M4/M6		2x	1 of 2
HW7	M4 x 50MM C/B SCREW		8x	1 of 2

SAFAVIEH FURNITURE

ITEM : DTB4305A

DIMENSION : W64.96"x D35.4"x H29.9"

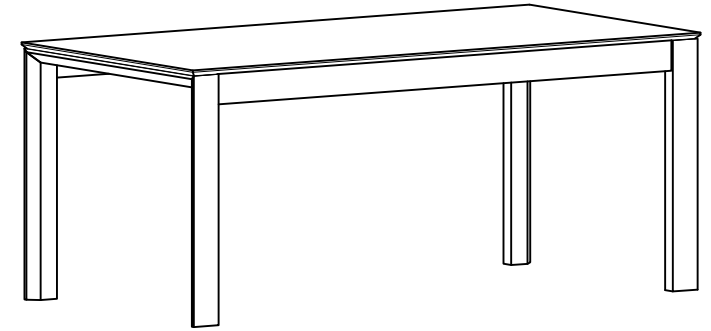

WARNING

Weight Capacity- 225 LBS
Warning: Do not stand on Table
Warning: Do not over torque Bolts

PREPARATION

- * Before beginning assembly of product, make sure all parts are present. Compare parts with contents list and hardware contents list.
- * If any part is missing or damaged, do not attempt to assemble the product.
- * Estimated Assembly Time: 10 minutes.
- * Tools Required for Assembly (Included): Allen Key
- * Tools Required for Assembly (Not Included): Screw Driver
- * If you are having difficulty, our friendly Customer Care team is always here to help. Please email customersupport@safavieh.com

STEP 1

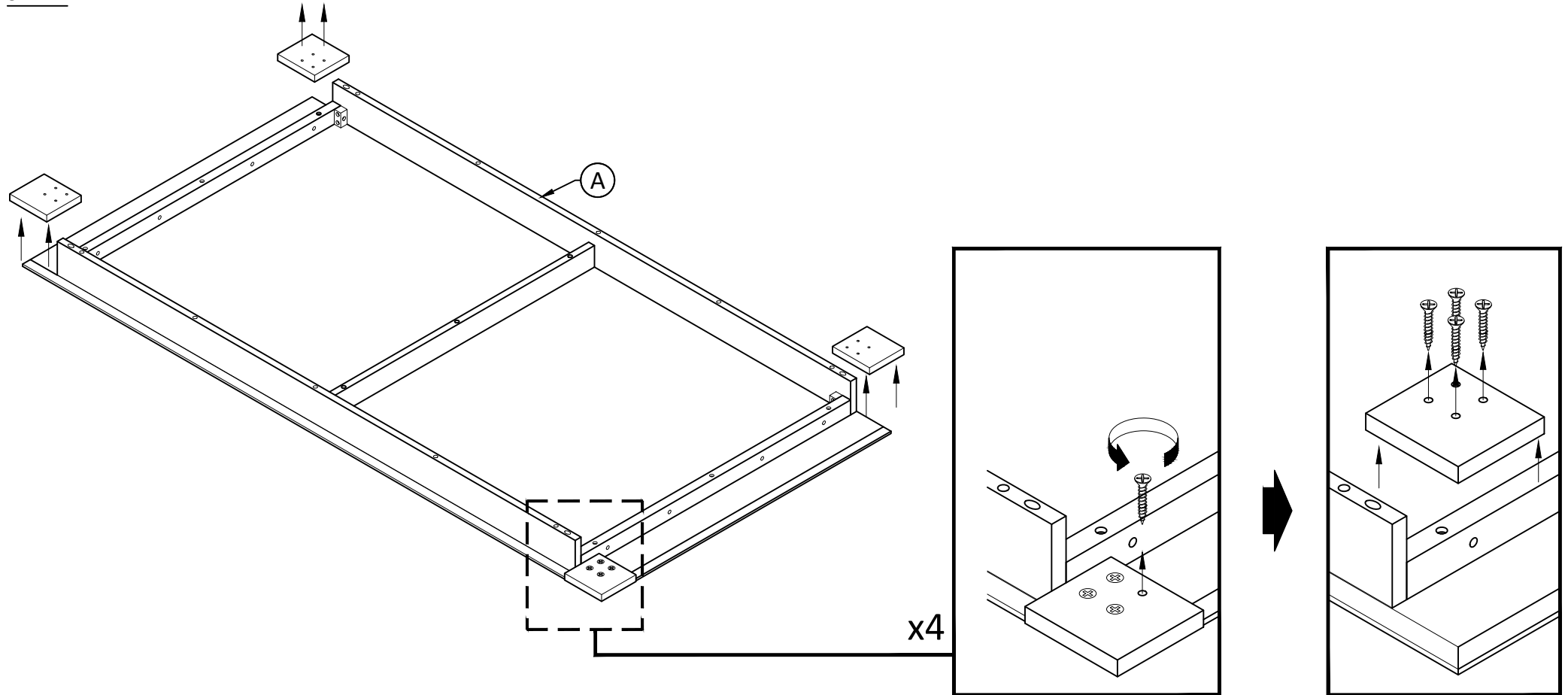

Take all the parts out.

Remove the screw from all corner block as shown. The corner and panel blocks are pre-installed to protect the unit during shipping. After removing them in Step 1, please discard both the blocks and screws. These components are not required for final assembly.

STEP 2

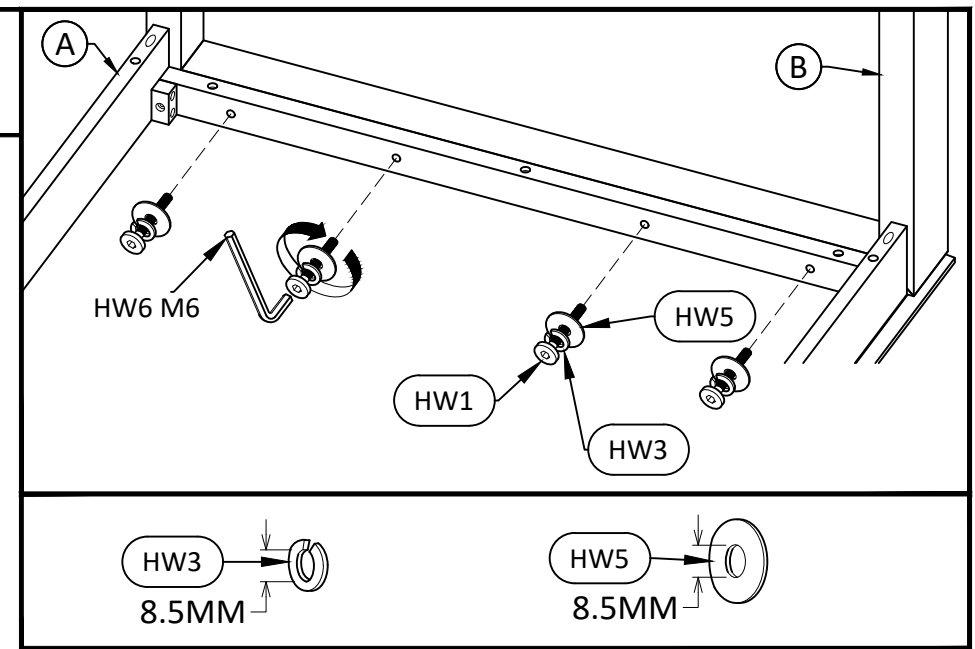
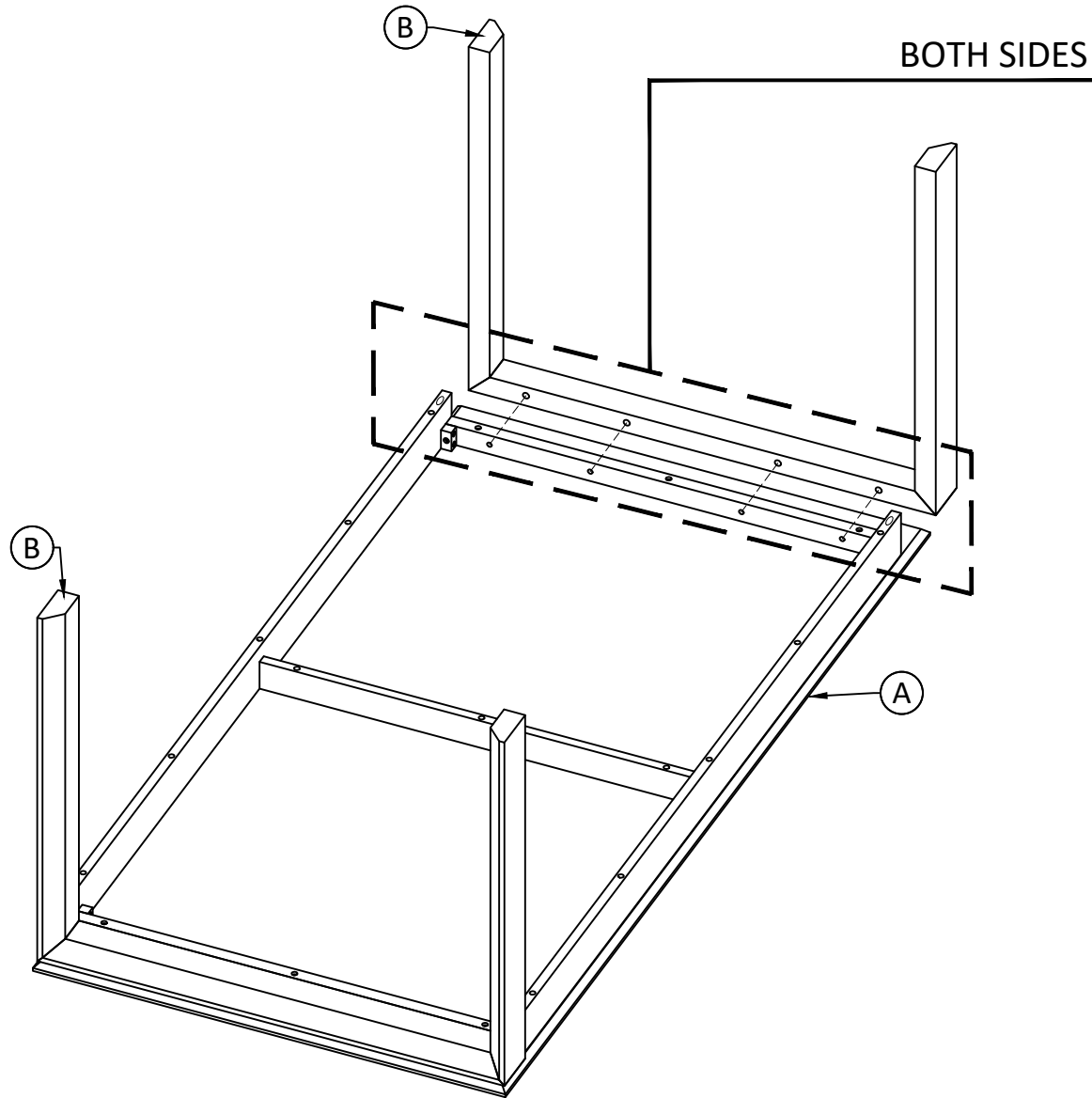

Attach connection the Table Leg(B) onto the Table Top(A) as shown.
Position Table Leg(B) with holes facing to corner block holes of table frame. Insert Split Washer(HW3), Flat Washer(HW5) & JCB Bolt(HW1) then tighten with Allen Key (HW6 M6) provided. Repeat Step 2 for another legs assembly.

STEP 3

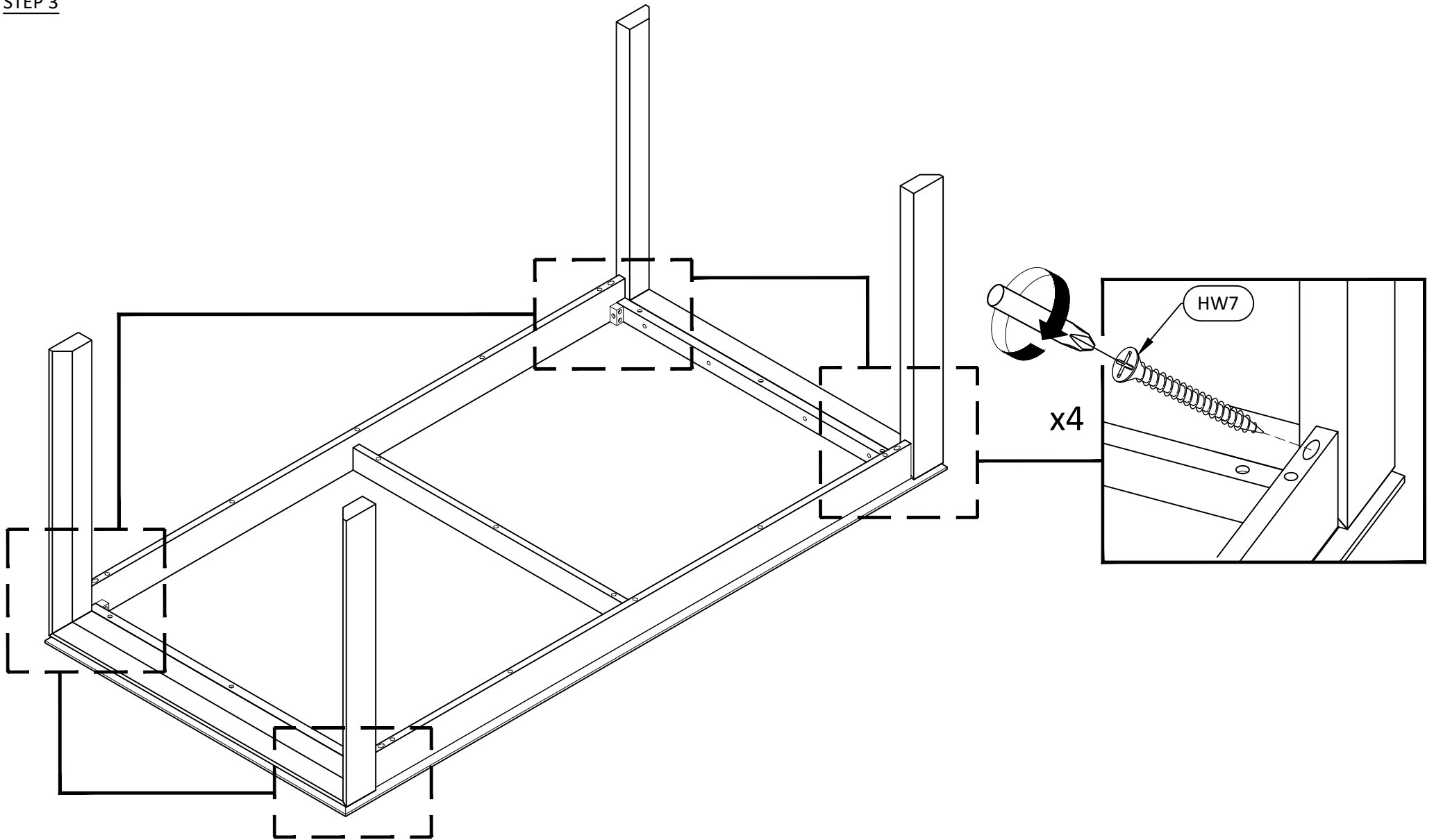

Insert the C/B Screw(HW7) to hole as shown. Then tighten with screw driver not provided. Repeat Step 3 for every side scope as shown.

STEP 4

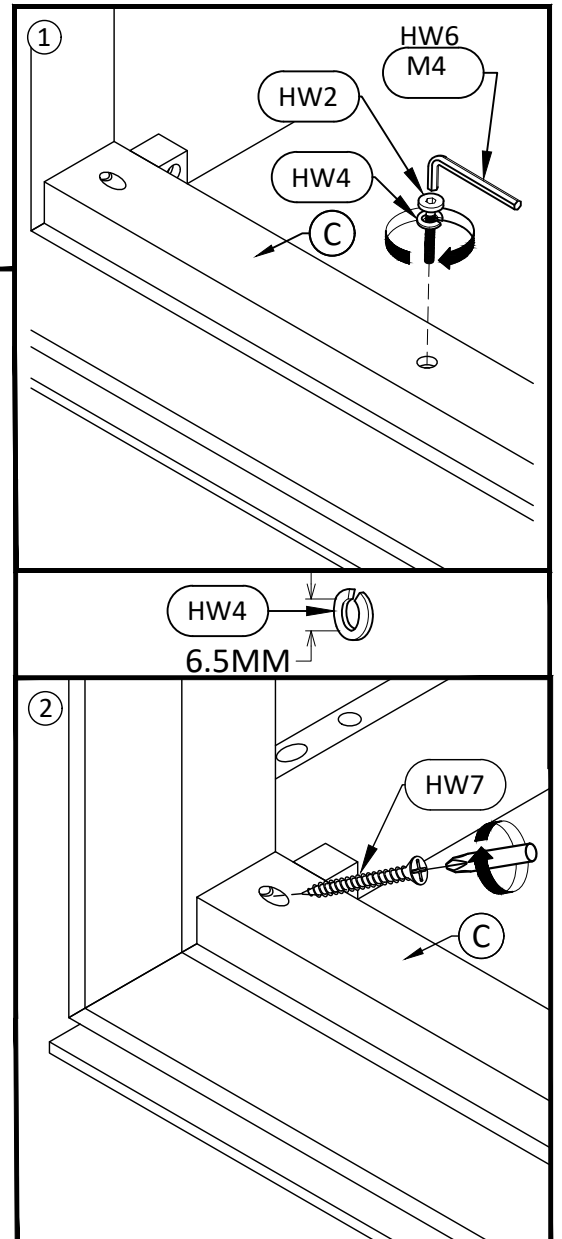
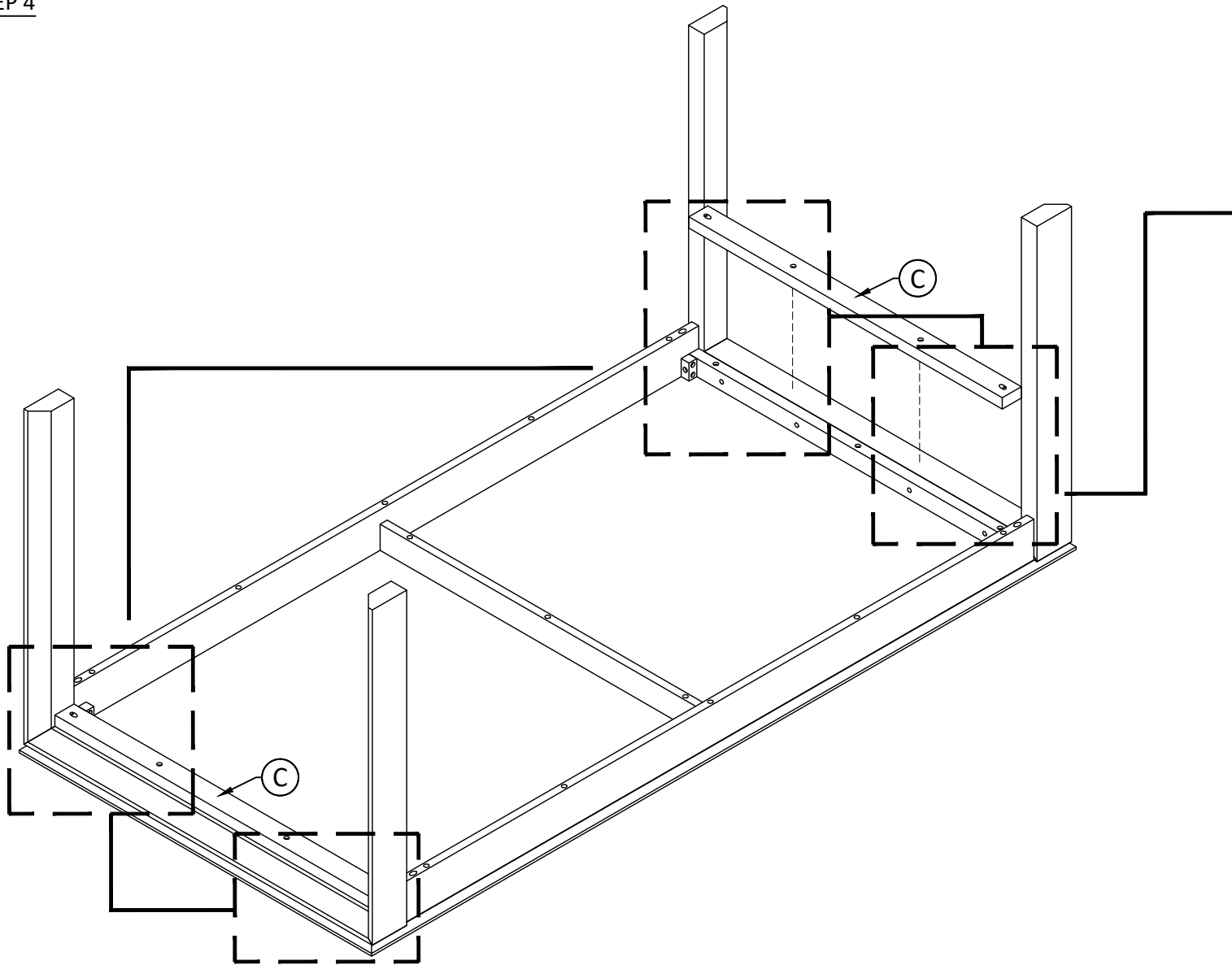

Position support leg(C) with holes facing to the leg holes of table. Insert Split Washer(HW4) & JCBC Bolt(HW2) then tighten with Allen Key (HW6 M4) provided. After that insert the C/B Screw(HW7) to hole as shown. Then tighten with screw driver not provided. Repeat Step 4 for every side scope as shown.