

ASSEMBLY INSTRUCTIONS

Bench

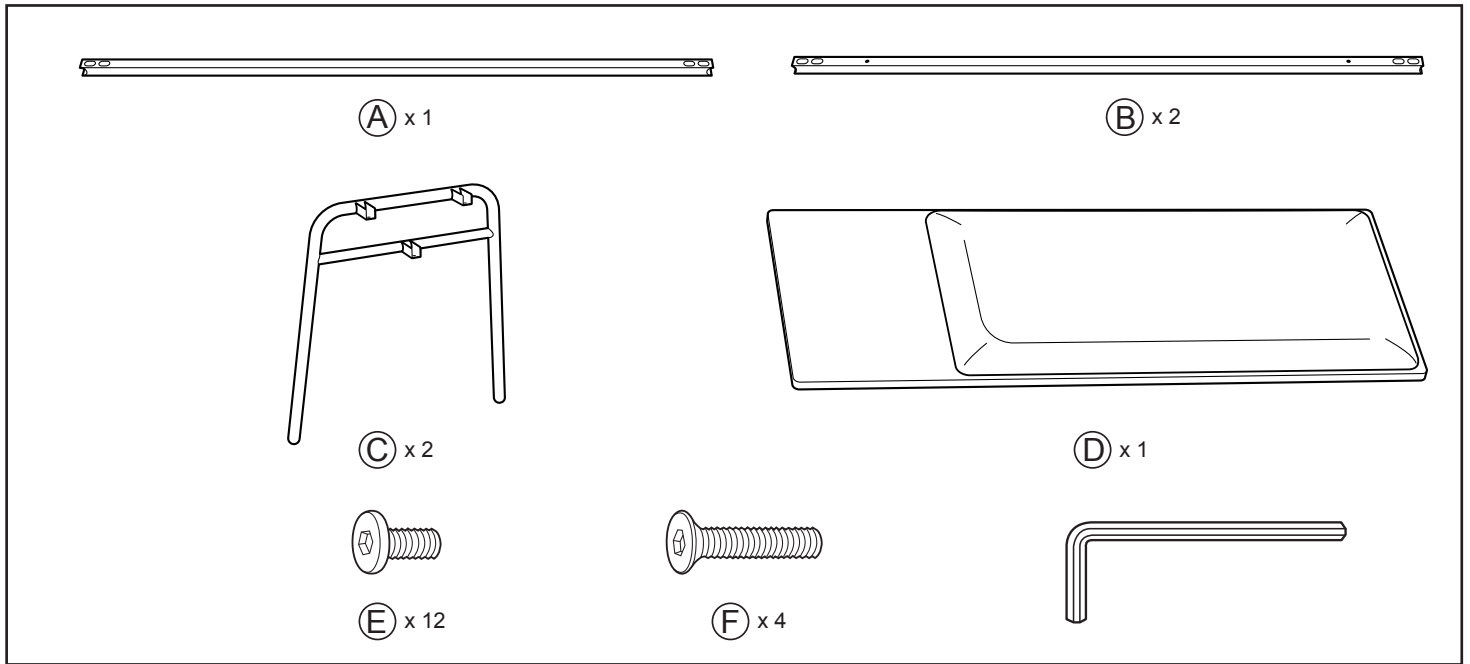

CAUTION : DO NOT TIGHTEN SCREWS COMPLETELY UNTIL ALL THE SCREWS ARE FIXED IN THE CORRECT POSITION

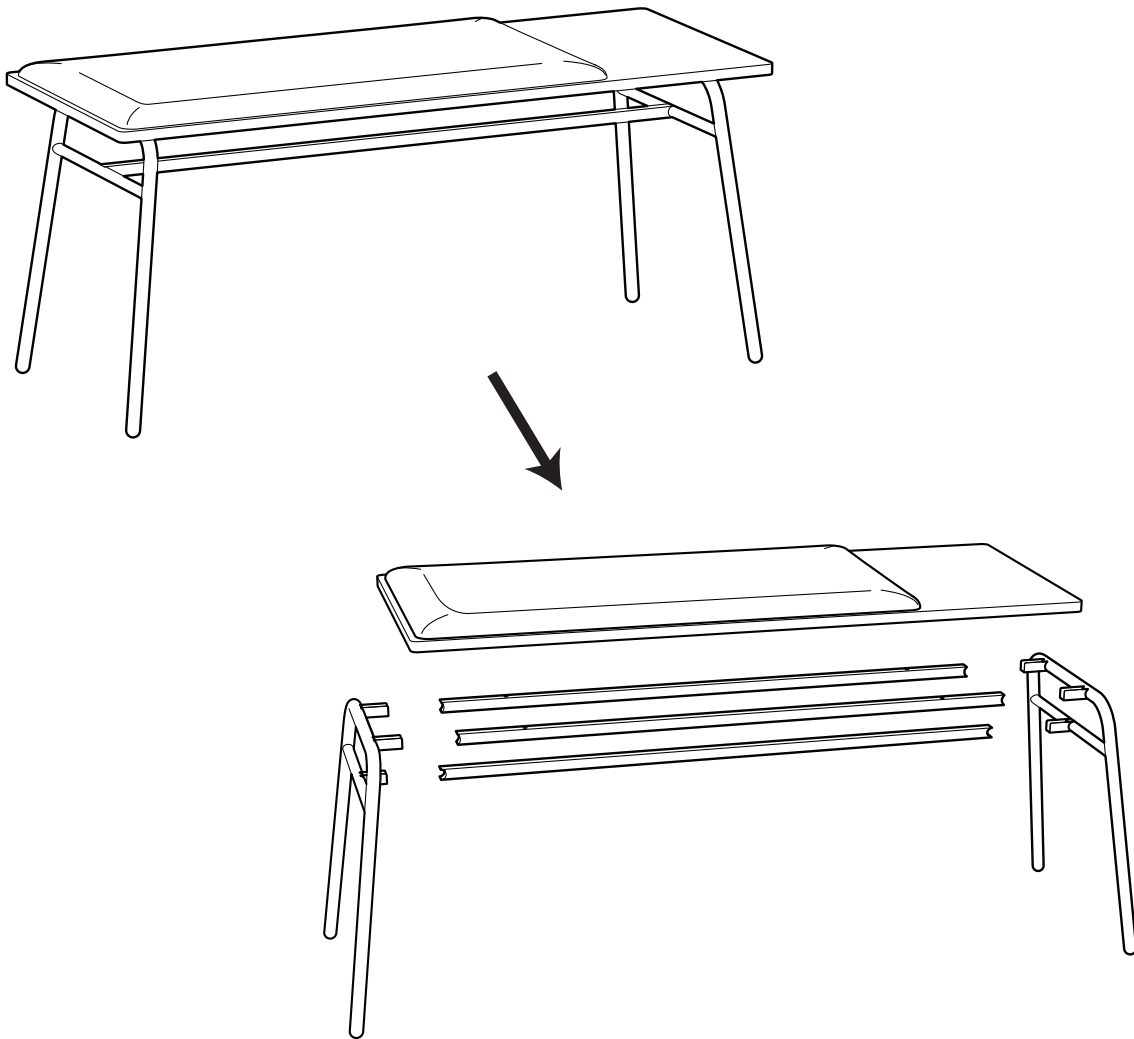

WEIGHT CAPACITY: 150 KGS (330 LBS)

1

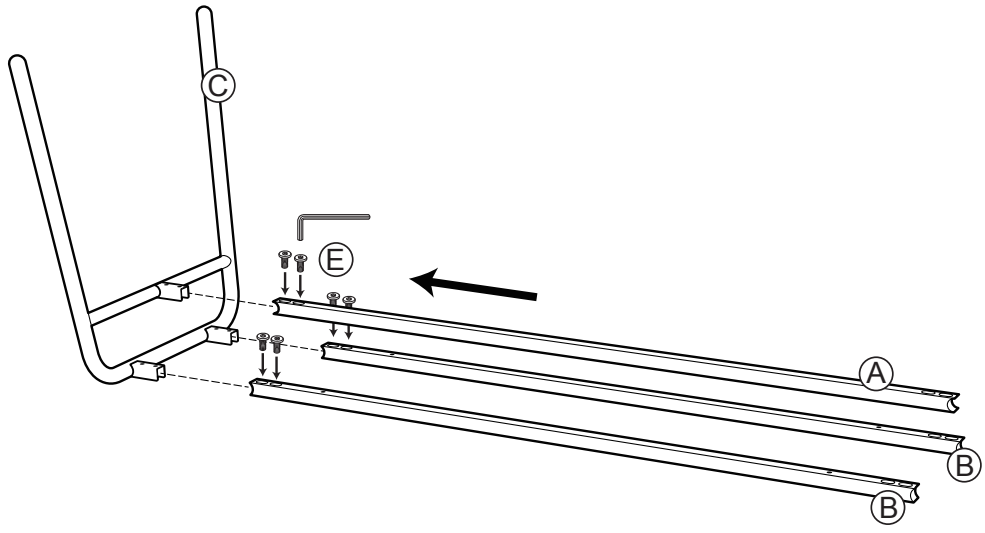

2

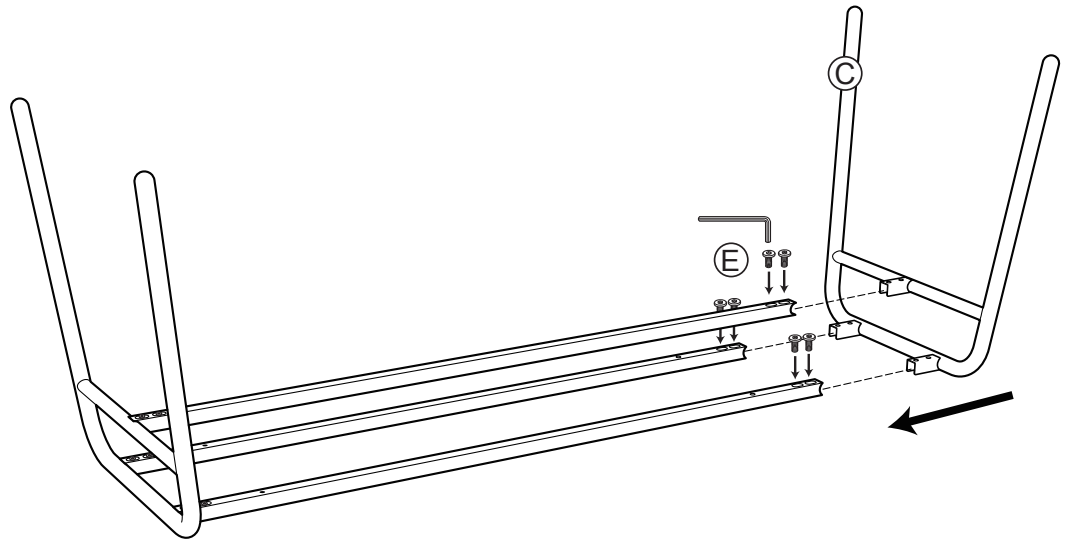

3

