

# ASSEMBLY INSTRUCTION

## DINING TABLE

**A** Table Top



1 pc

**B** Table Leg



4 pcs

**C** Jcbb Bolt  
M8 x 80mm

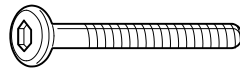

8 pcs

**D** Spring Washer  
M8



8 pcs

**E** Flat Washer  
M8 x 22mm



8 pcs

**F** Allen Key  
M8



1 pc



This page lists all the contents included in the box. Please take the time to identify the hardware as well as the individual components to this product. As you unpack and prepare for assembly, place the contents on a carpeted or padded area to protect them from damage.

**1**

Put the Table Top (A) upside down on the soft and smooth surface. Attach Table Leg (B) onto Table Top (A). Then insert Jcbb Bolt (C), Spring Washer (D) and Flat Washer (E) into holes of each corner block of Table Top (A) by using Allen Key (F). Do not fully tighten the bolts in this step.

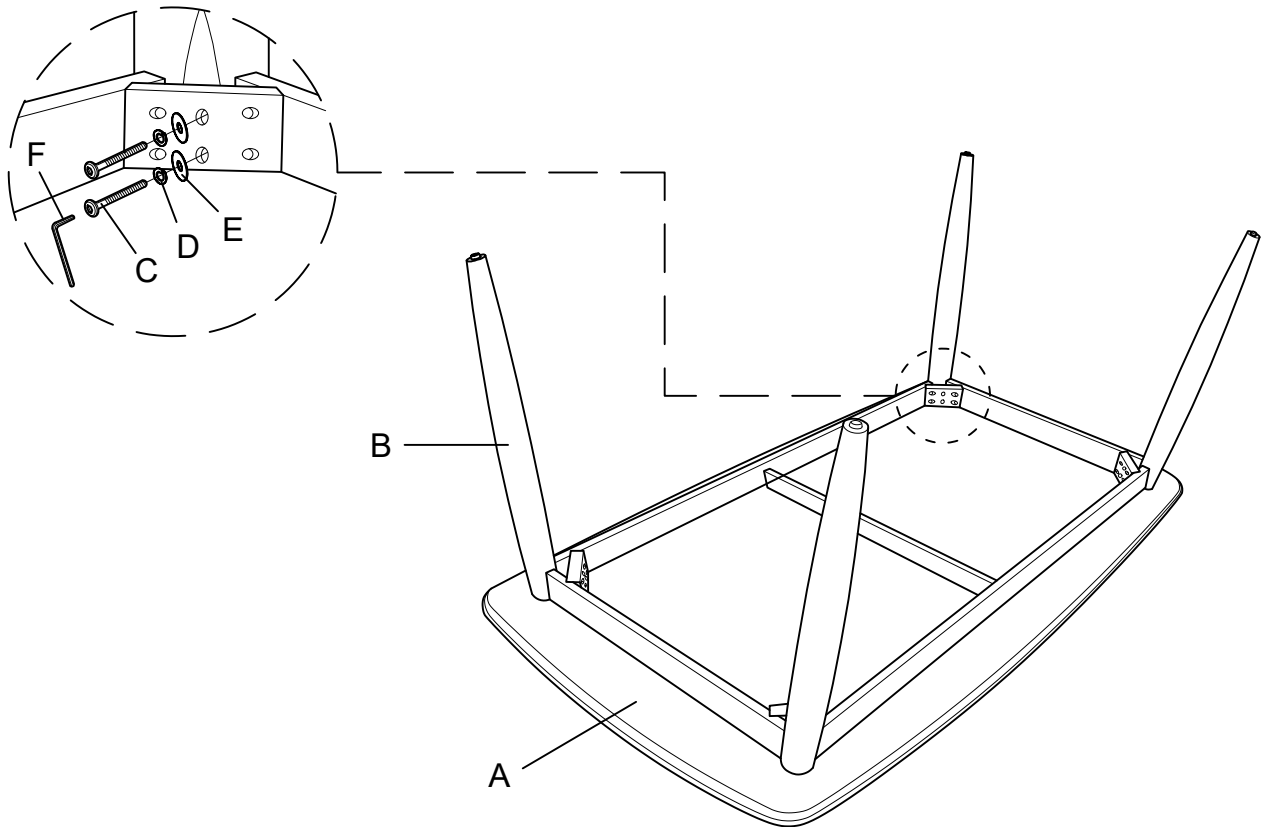

Stand table up on an even surface and check that it is balanced. If there is a slight wobble, apply downward pressure in the corner where a leg is uneven. Keeping pressure in that corner, tighten all bolts. If balanced, apply downward pressure evenly in the center and tighten all bolts. Do not over-tighten beyond hole depth.

#### Cleaning & Care

Treat surface with care. Surface is resistant to scratches but is not scratch resistant. Clean surface with a dry or damp soft cloth. Do not use abrasive cleaners. Hardware may loosen over time. Periodically check that all connections are tight.

# ASSEMBLY INSTRUCTION

## SIDE CHAIR

**A** Back Rest

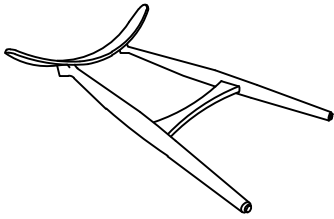

1pc

**B** Front Leg Frame

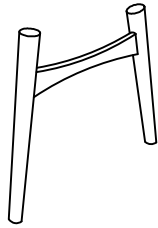

1pc

**C** Side Rail (Left & Right)

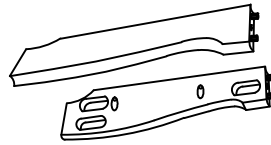

2pcs

**D** Cushion



1pc

**E** Jcbc Bolt M6 x 50mm

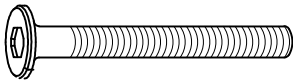

6 pcs

**F** Spring Washer M6



6 pcs

**G** Flat Washer M6 x 13mm



6 pcs

**H** CSK CB Screw M4 x 32mm

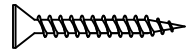

4 pcs

**I** Allen Key M4 x 110



1pc

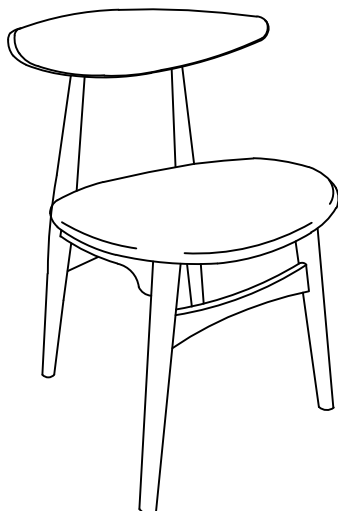

This page lists all the contents included in the box. Please take the time to identify the hardware as well as the individual components to this product. As you unpack and prepare for assembly, place the contents on a carpeted or padded area to protect them from damage.

**1**

Put the Back Rest (A) upside down on the soft and smooth surface. With assistance attach Side Rail (C) Left & Right onto Backrest (A). Then insert Jcbs Bolt (E), Spring Washer (F) and Flat Washer (G) into predrilled holes of each Side Rail, by using Allen Key (I). Do not fully tighten the bolts in this step.

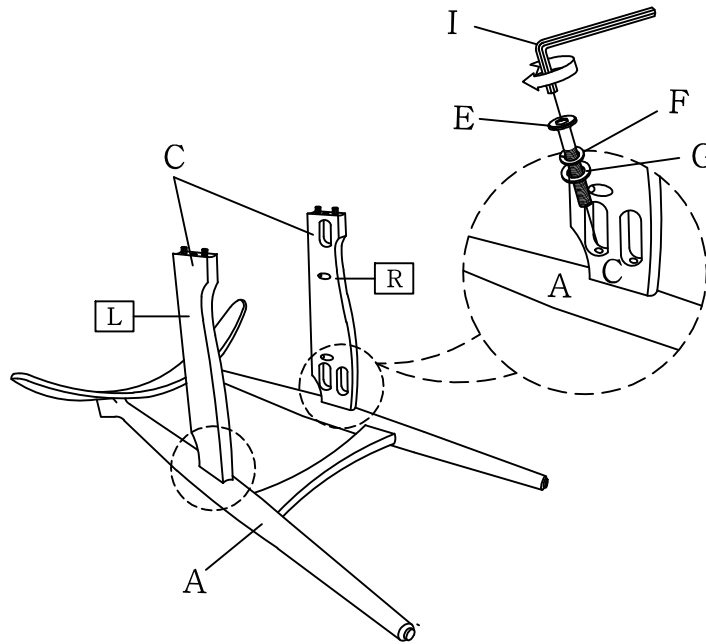

Take the Allen Wrench, and turn the bolts until the legs are secure. **DO NOT TIGHTEN COMPLETELY.** Stop when you feel you are adding force to tighten the bolt.

**2**

Attach Front Legs (B) onto Side Rail (C), insert Flat Washer (G), Spring Washer (F) and Jcbs Bolt (E) using Allen Key (I).

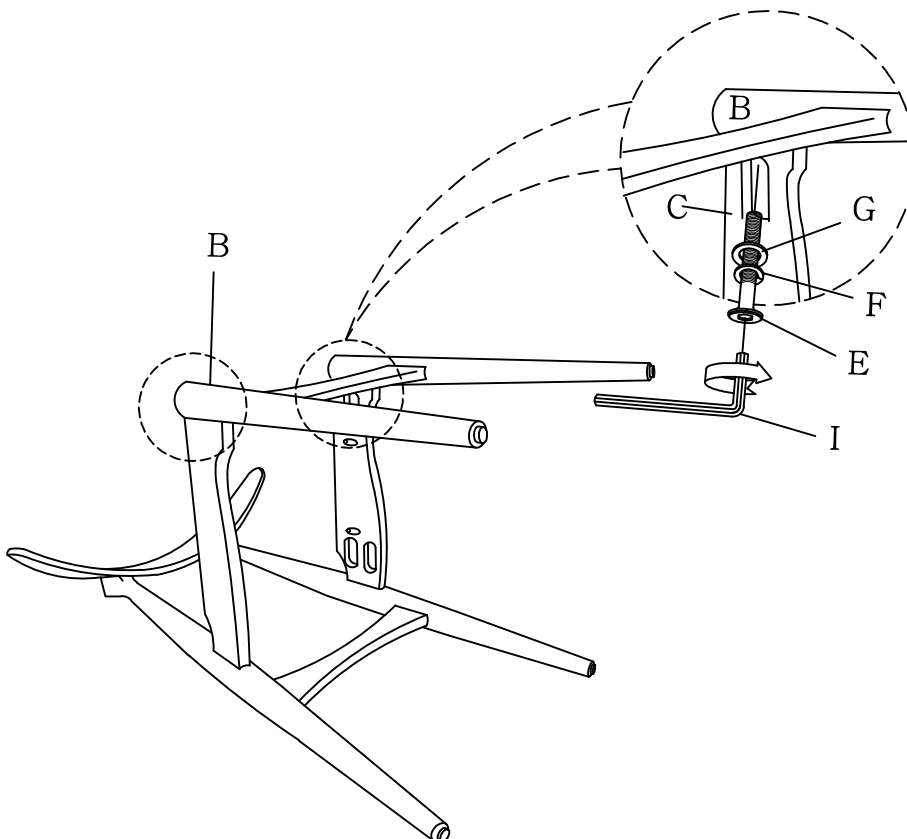

**3** Stand chair up on an even surface and check that it is balanced. If there is a slight wobble, apply downward pressure on each corner where a leg is uneven. Keeping pressure in that corner, tighten all bolts. If balanced, apply downward pressure evenly in the center and tighten all bolts. Do not over-tighten beyond hole depth.

While the chair legs uneven after assembled, please adjust the adjustable glide to make it balance.

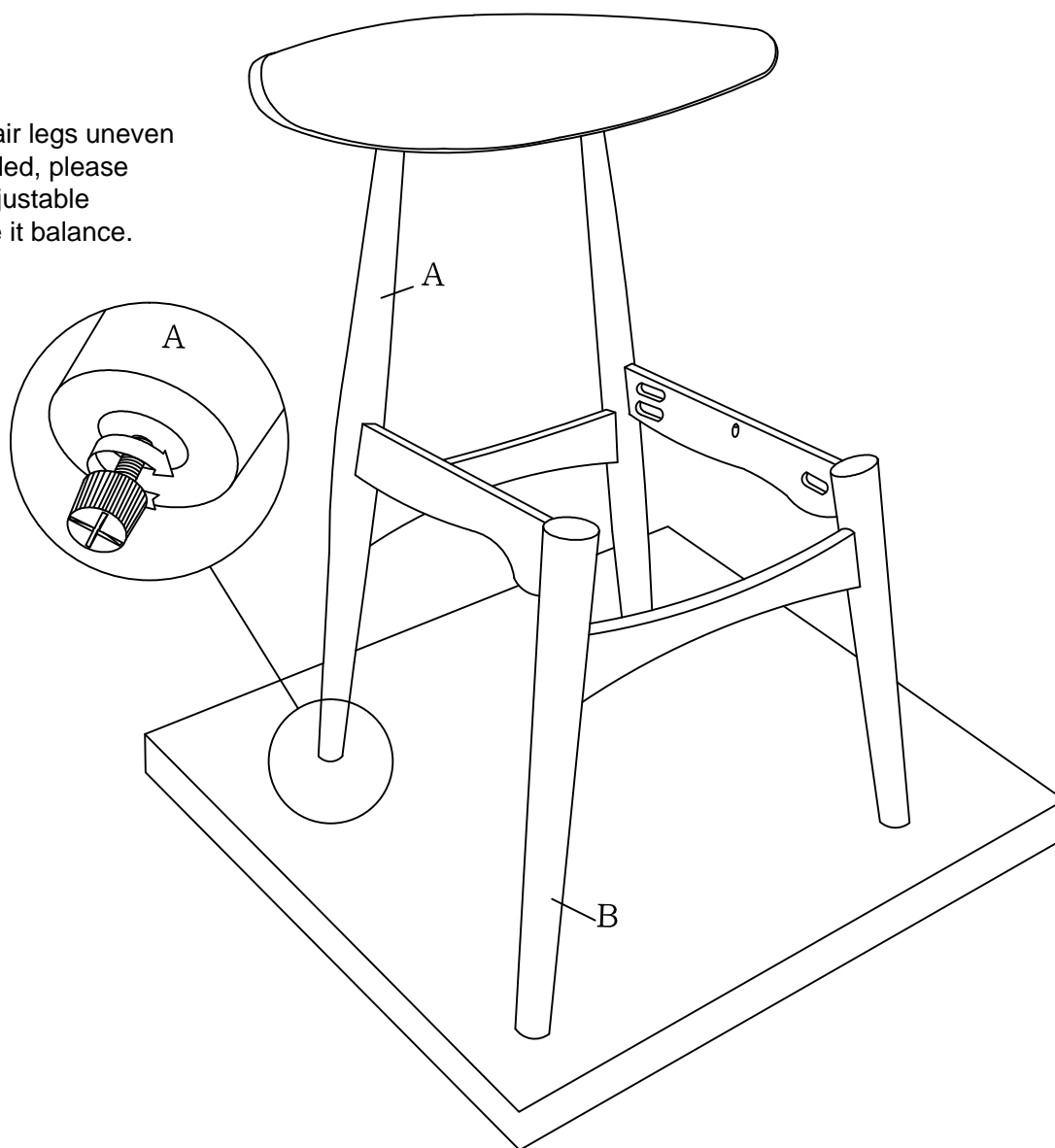

*Helpful Tip:* -Have someone applying downward pressure on the chair while you tighten the bolts.

4

Attach Cushion Seat (D) with Csk-Cb Screw (H) by using Screwdriver (not included). Tighten all wood screws in this step.

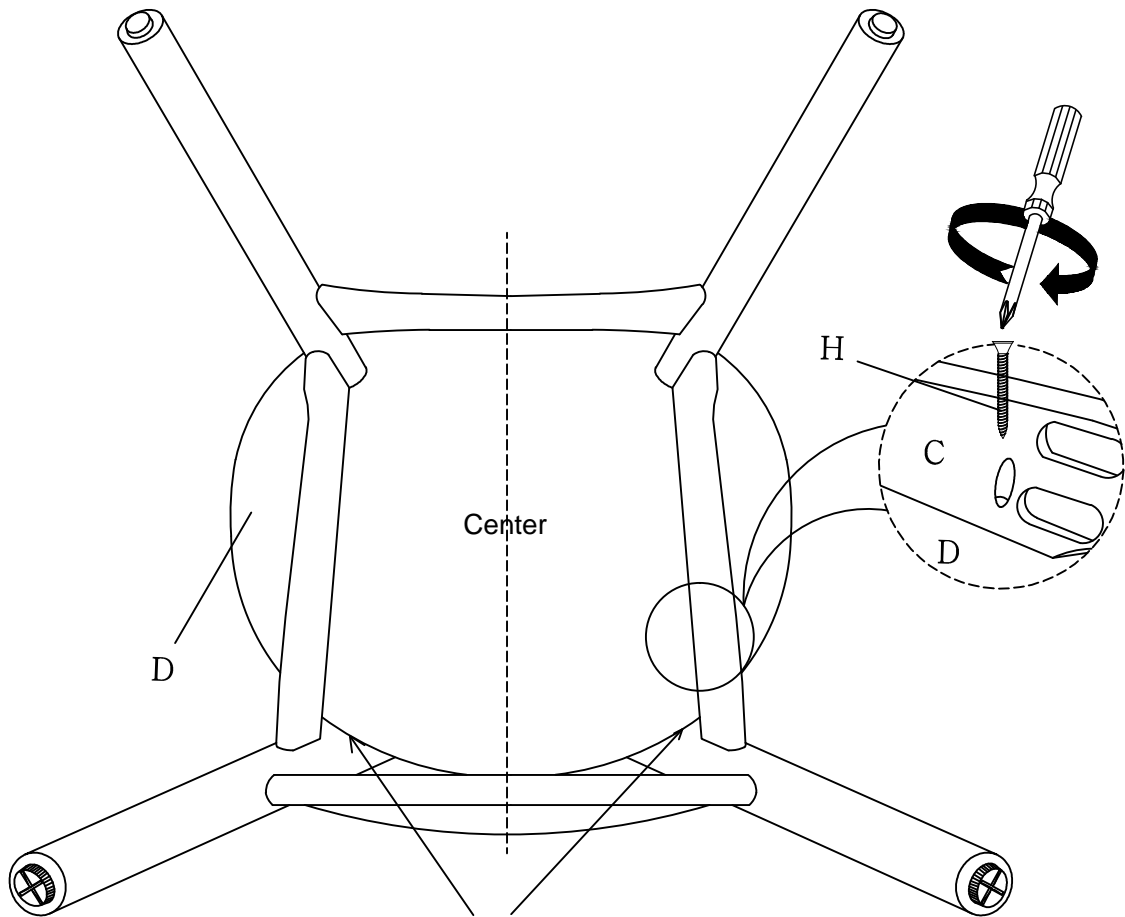

### Cleaning & Care

Treat surface with care. Surface is resistant to scratches but is not scratch resistant. Clean surface with a dry or damp soft cloth. Do not use abrasive cleaners. Hardware may loosen over time. Periodically check that all connections are tight.

# ASSEMBLY INSTRUCTION

## BENCH

**A** Seat Frame & Seat

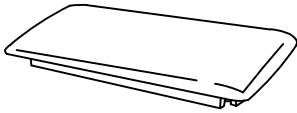

1 pc

**B** Leg



4 pcs

**C** Jcbc Bolt M6 x 70mm

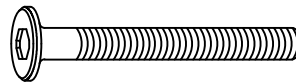

8 pcs

**D** Spring Washer M6



8 pcs

**E** Flat Washer M6



8 pcs

**F** Allen Key



1 pc

**G** Felt Pad



4 pcs



This page lists all the contents included in the box. Please take the time to identify the hardware as well as the individual components to this product. As you unpack and prepare for assembly, place the contents on a carpeted or padded area to protect them from damage.

**1**

Put the Seat Frame & Seat (A) upside down on the soft and smooth surface. Attach Leg (B) onto Seat Frame & Seat (A). Then insert Jcbc Bolt (C), Spring Washer (D) and Flat Washer (E) into holes of each Corner Block of Seat Frame & Seat (A) by using Allen Key (F). Put the Felt Pad (G) on the bottom surface of the Leg (B).

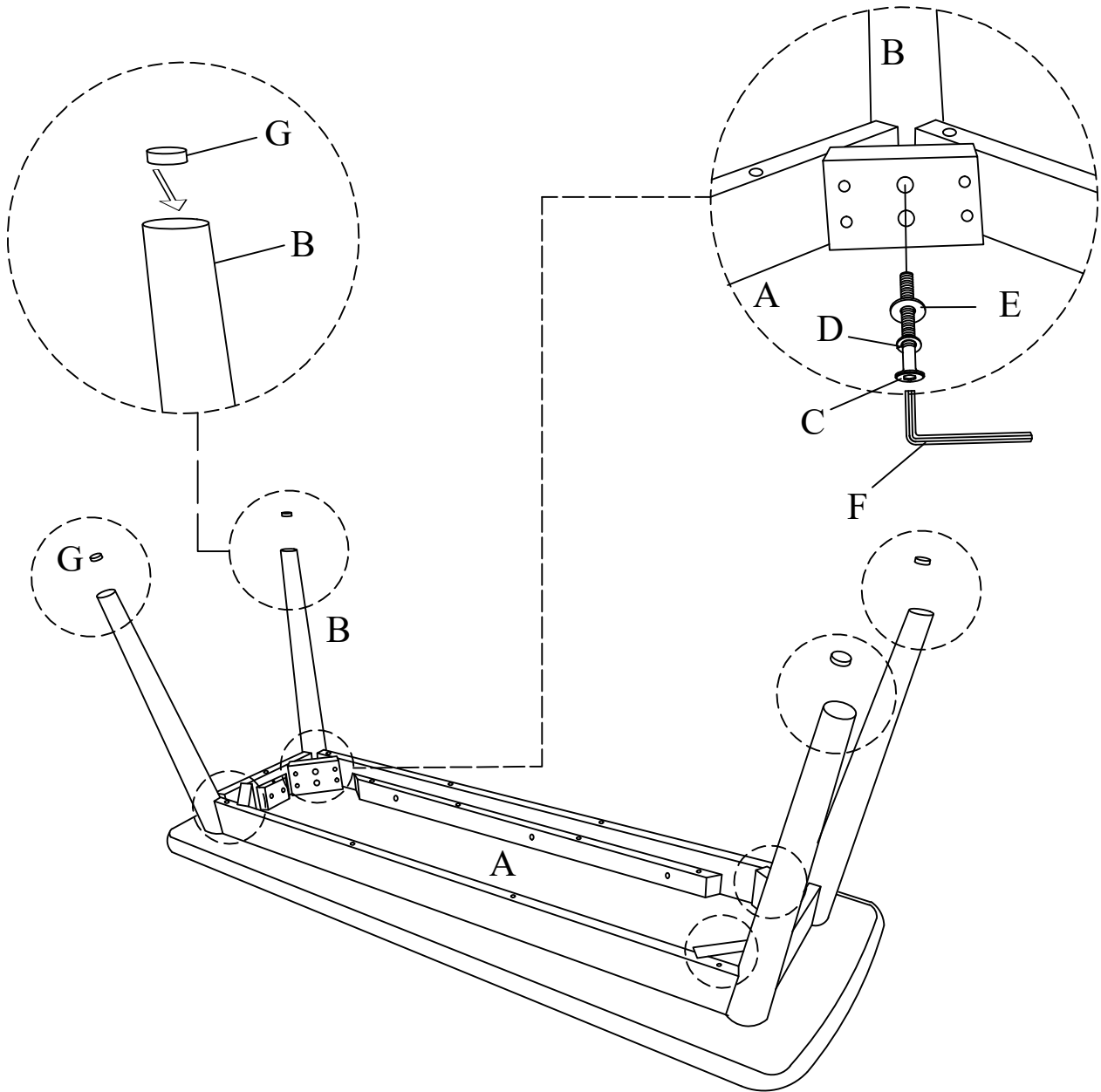

Stand chair up on an even surface and check that it is balanced. If there is a slight wobble, apply downward pressure in the corner where a leg is uneven. Keeping pressure in that corner, tighten all bolts. If balanced, apply downward pressure evenly in the center and tighten all bolts. Do not over-tighten beyond hole depth.

*Helpful Tip:*-Instead of applying downward pressure while reaching under to tighten bolts, have someone sit in the chair while you tighten the bolts.

### Cleaning & Care

Treat surface with care. Surface is resistant to scratches but is not scratch resistant. Clean surface with a dry or damp soft cloth. Do not use abrasive cleaners. Hardware may loosen over time. Periodically check that all connections are tight.