

Your **holder** for all
things awesome.

Industrial Style TV Stand

NOTE: THIS INSTRUCTION
BOOKLET CONTAINS **IMPORTANT**
SAFETY INFORMATION.

PLEASE READ AND KEEP FOR
FUTURE REFERENCE.

Table of Contents

Part Identification	3
Hardware Identification	4
Assembly Steps	5-10

⚠ WARNING

Use of a TV that is too heavy or large is hazardous. A TV that is too heavy will create a risk of a tip-over that can cause severe injury or death. A TV that is too large for the available space might be accidentally pushed or bumped off the furniture, or subject to tip-over.

- Check the size and weight of your TV. Compare it to the diagram below – **before you begin assembly!**
- This unit is designed for use with televisions weighing less than 50 or 95 pounds. **Never** use with a TV that weighs more. • The size of the television, front-to-back and side-to-side, must fit within the space defined in the diagram.
 - **Never** place the front edge of the TV past the front edge of the TV support shelf (or stop molding – if equipped)
 - **Never** allow the sides of the TV to extend past the side edges of the TV support surface.
 - If the TV has a CRT picture tube, the picture tube cone may extend past the rear of the support shelf.
- Be sure to apply the warning label as instructed in the last assembly step. The label provides important safety related information.

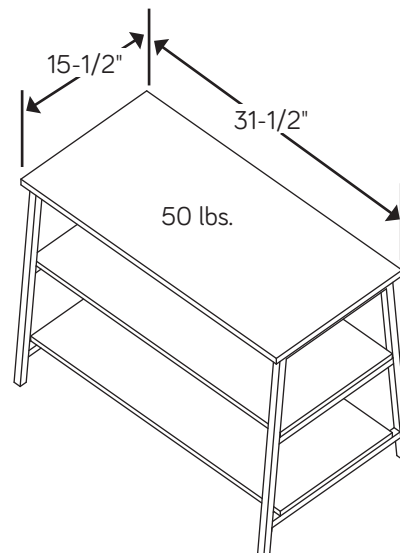
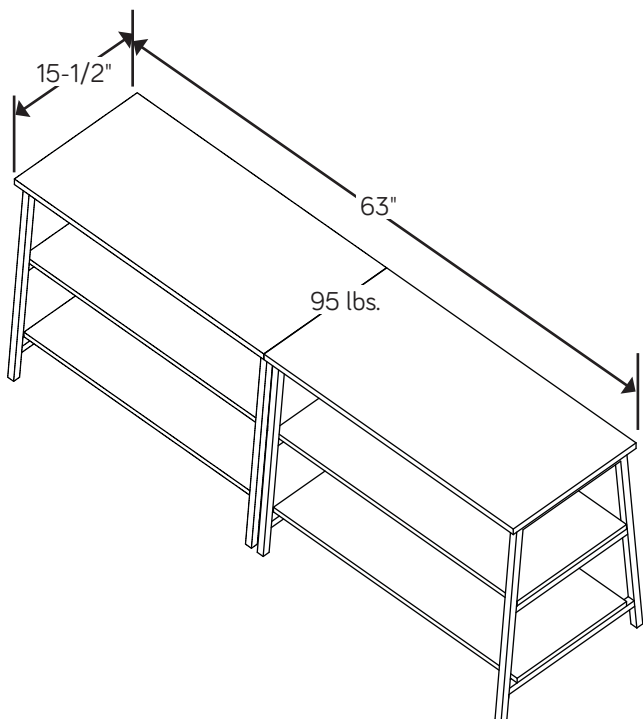

Part Identification

Now you know
our ABCs.



↑ While not all parts are labeled, some of the parts will have a label or an inked letter on the edge to help distinguish similar parts from each other. Use this part identification to help identify similar parts.

A	END (2)
B	LONG SHELF (1)
C	SHORT SHELF (1)
D	SMALL SHELF (1)
E	BRACE (3)

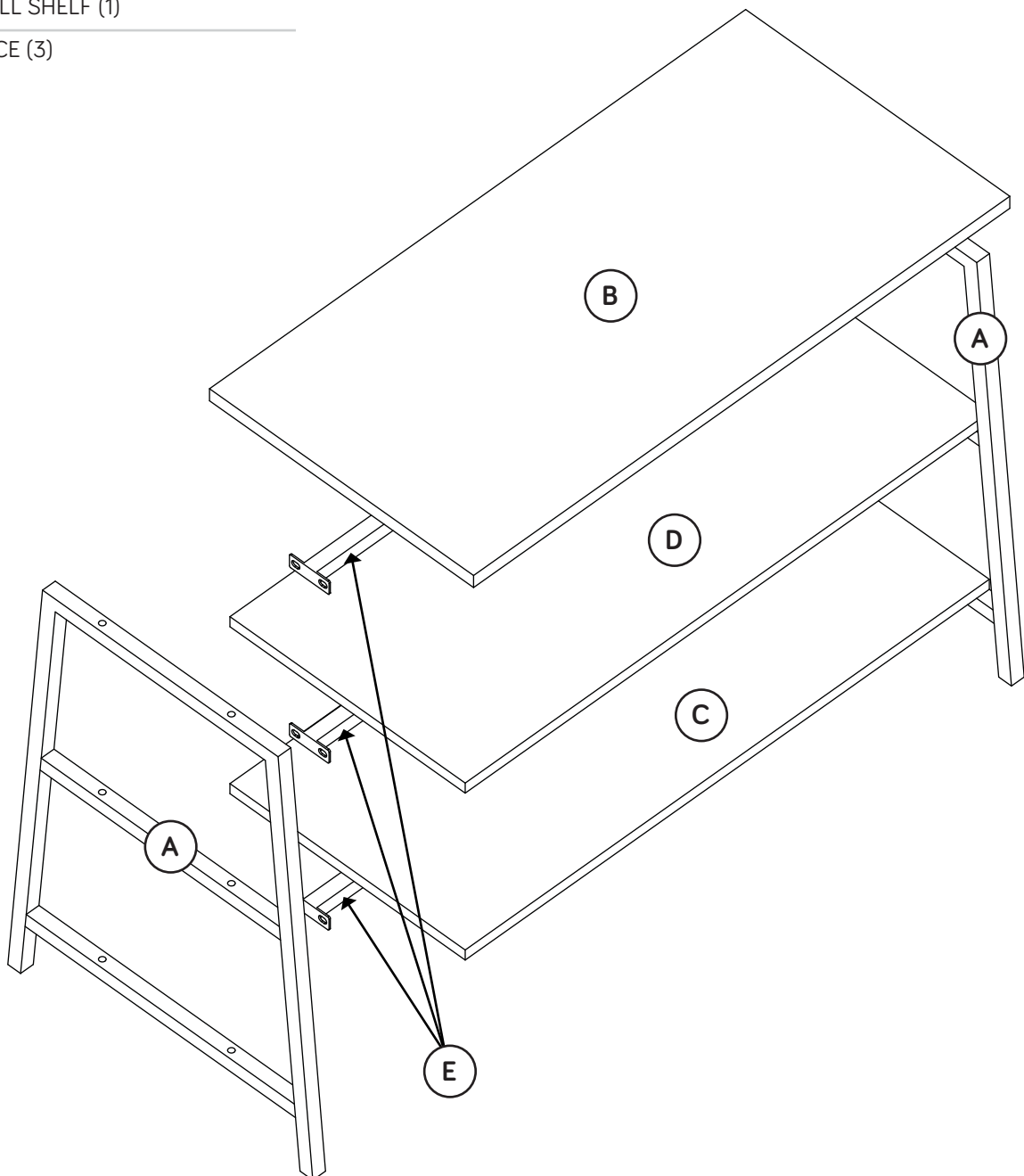

Hardware Identification

↑ Screws are shown actual size. You may receive extra hardware with your unit.

1 1-3/16" ALLEN SCREW - 18

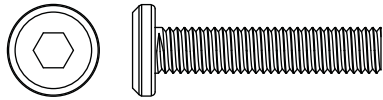

2 1/2" ALLEN SCREW - 12

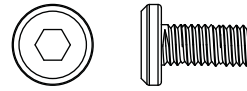

3 TIE PLATE - 2

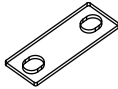

4 WARNING LABEL - 1
(for single unit)



(Refer to the last step for proper location and application)

5 WARNING LABEL - 1
(for two units)

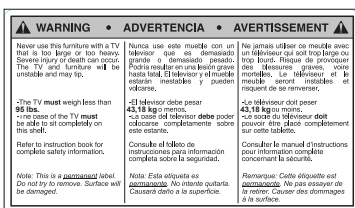

(Refer to the last step for proper location and application)

6 ALLEN WRENCH - 1



Step 1

- ✚ Assemble your unit on a carpeted floor or on the empty carton to avoid scratching your unit or the floor.
- ✚ **NOTE:** Do not completely tighten the SCREWS at this time.
- ✚ Fasten the ENDS (A) to the BRACES (E). Tighten twelve 1/2" ALLEN SCREWS (2) using the ALLEN WRENCH (6).

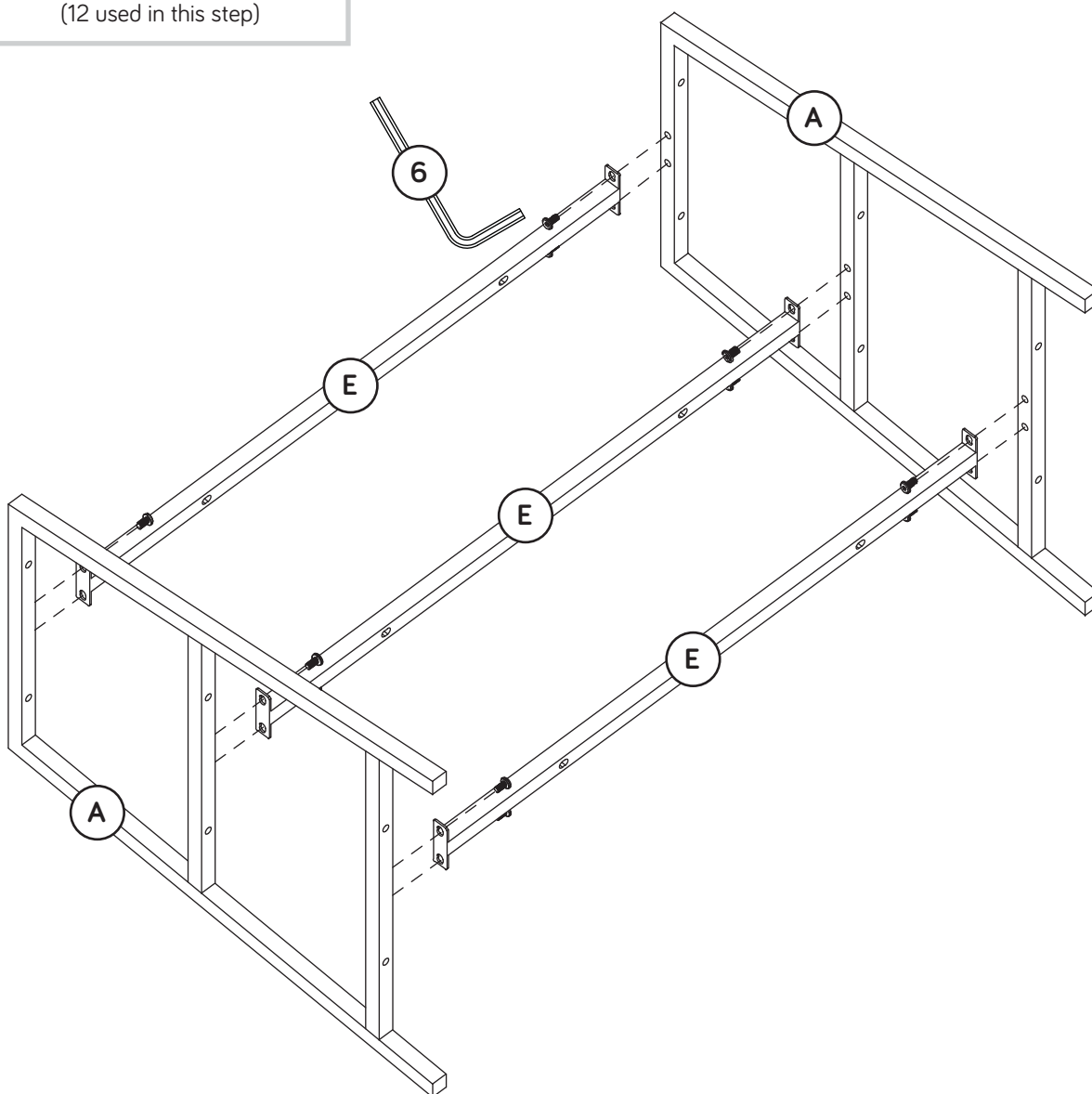
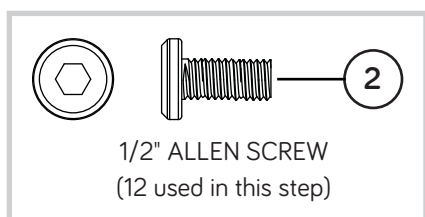

Step 2

- Slide the SHELVES (C and D) through the openings in the ENDS (A).
- Fasten the SHELVES (C and D) to the ENDS (A) and BRACES (E). Tighten twelve 1-3/16" ALLEN SCREWS (1) using the ALLEN WRENCH (6).
- Completely tighten all of the SCREWS.

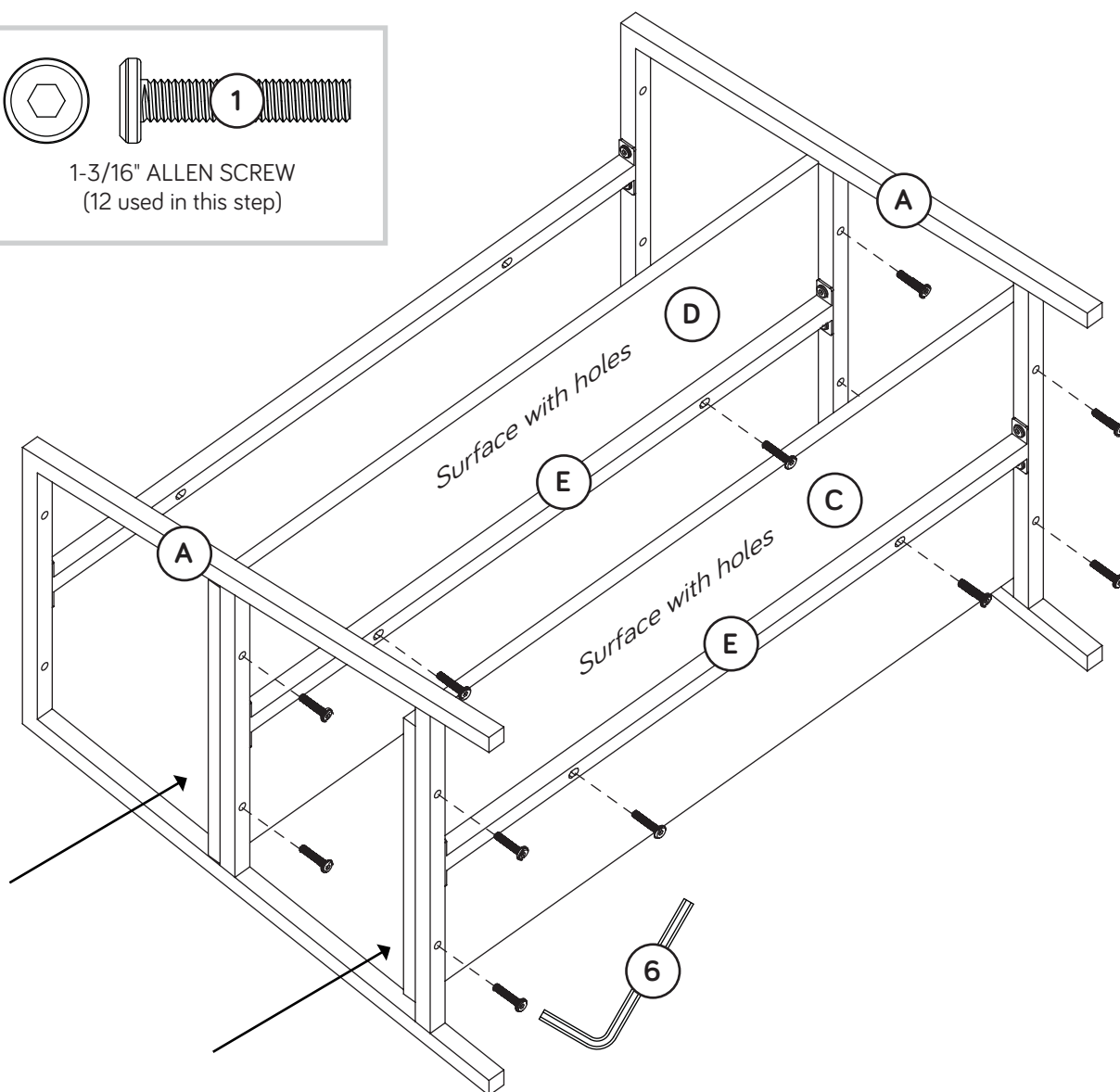
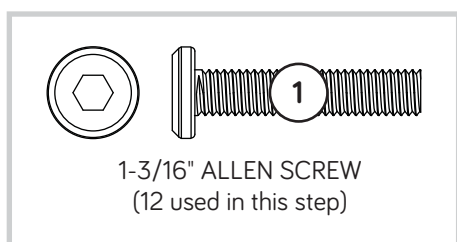

Step 3

- Fasten the LONG SHELF (B) to the ENDS (A) and BRACE (E). Tighten six 1-3/16" ALLEN SCREWS (1) using the ALLEN WRENCH (6).
- Carefully stand your unit upright.

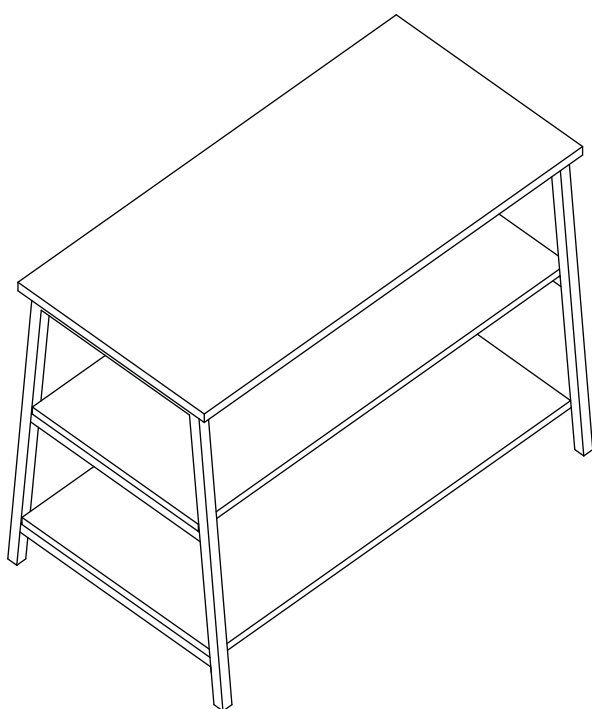
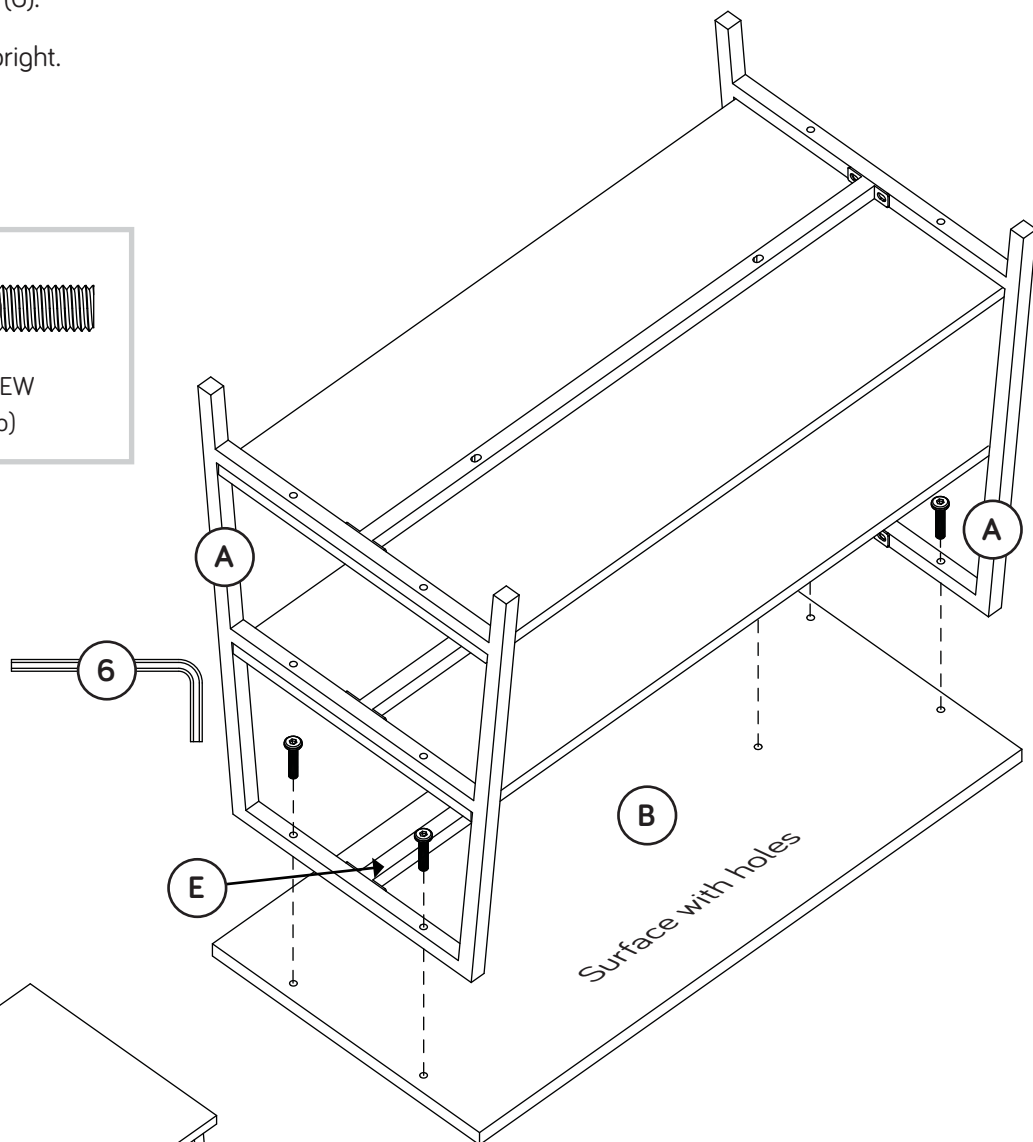
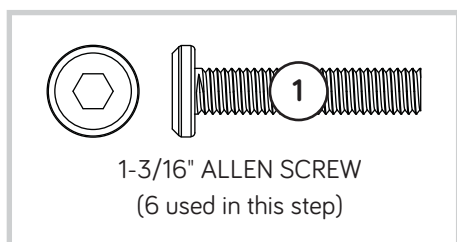

Step 4

- 🔩 NOTE: You can fasten two of the units side by side.
- 🔩 NOTE: If not fastening two units, go to Step 6.
- 🔩 If fastening two units together, remove two SCREWS from one end of the LONG SHELF (B) and two SCREWS from the same end of the SHORT SHELF (C).
- 🔩 Repeat this step to the opposite end in the second unit.
- 🔩 NOTE: You will have removed eight SCREWS.

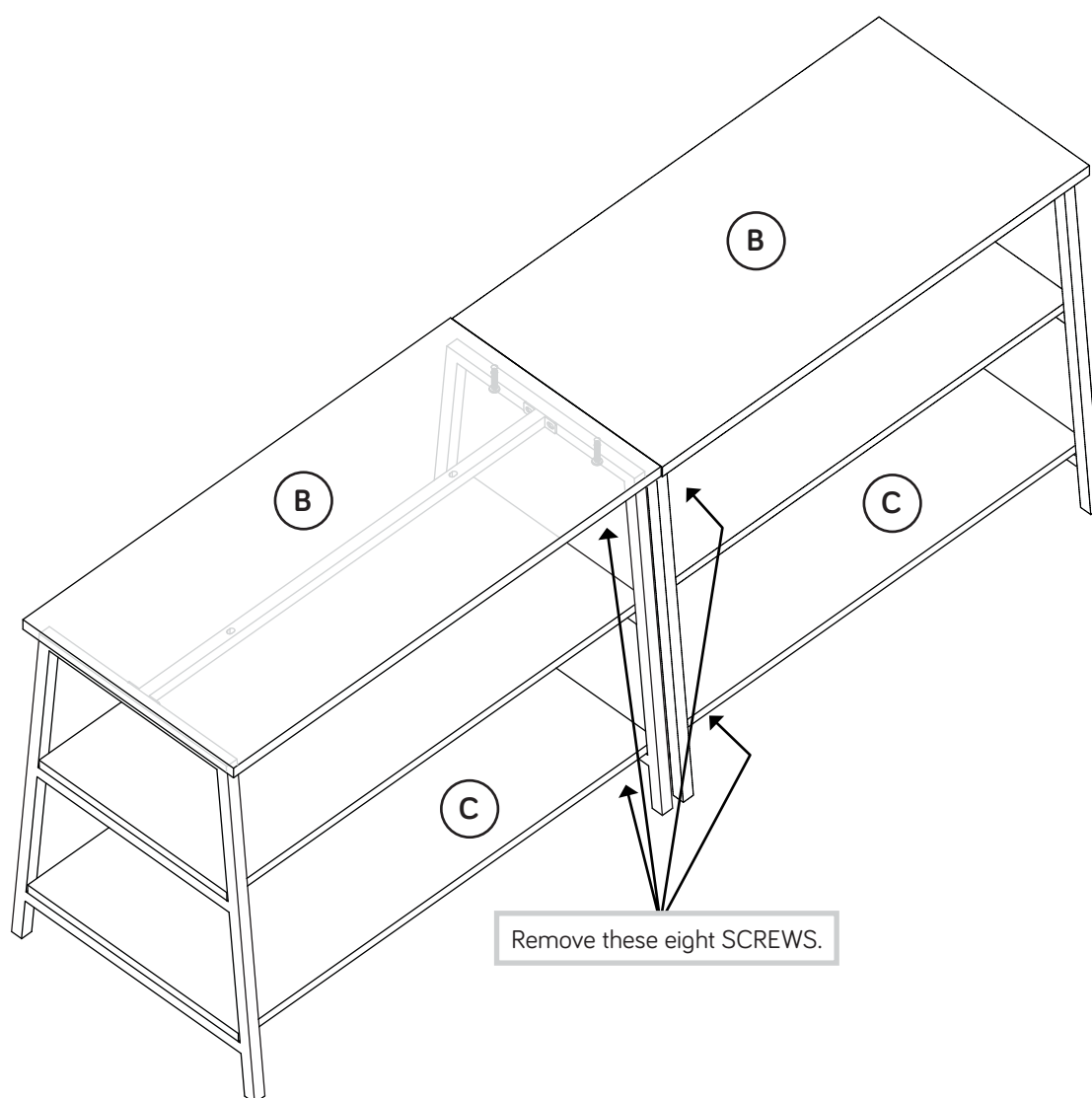

Step 5

- ✚ Fasten two units together using four TIE PLATES (3).
- ✚ Tighten eight 1-3/16" ALLEN SCREWS (1) (removed in Step 4) through the TIE PLATES (3), through the ENDS (A), and into the LONG SHELVES (B) and SHORT SHELVES (C) using the ALLEN WRENCH (6).

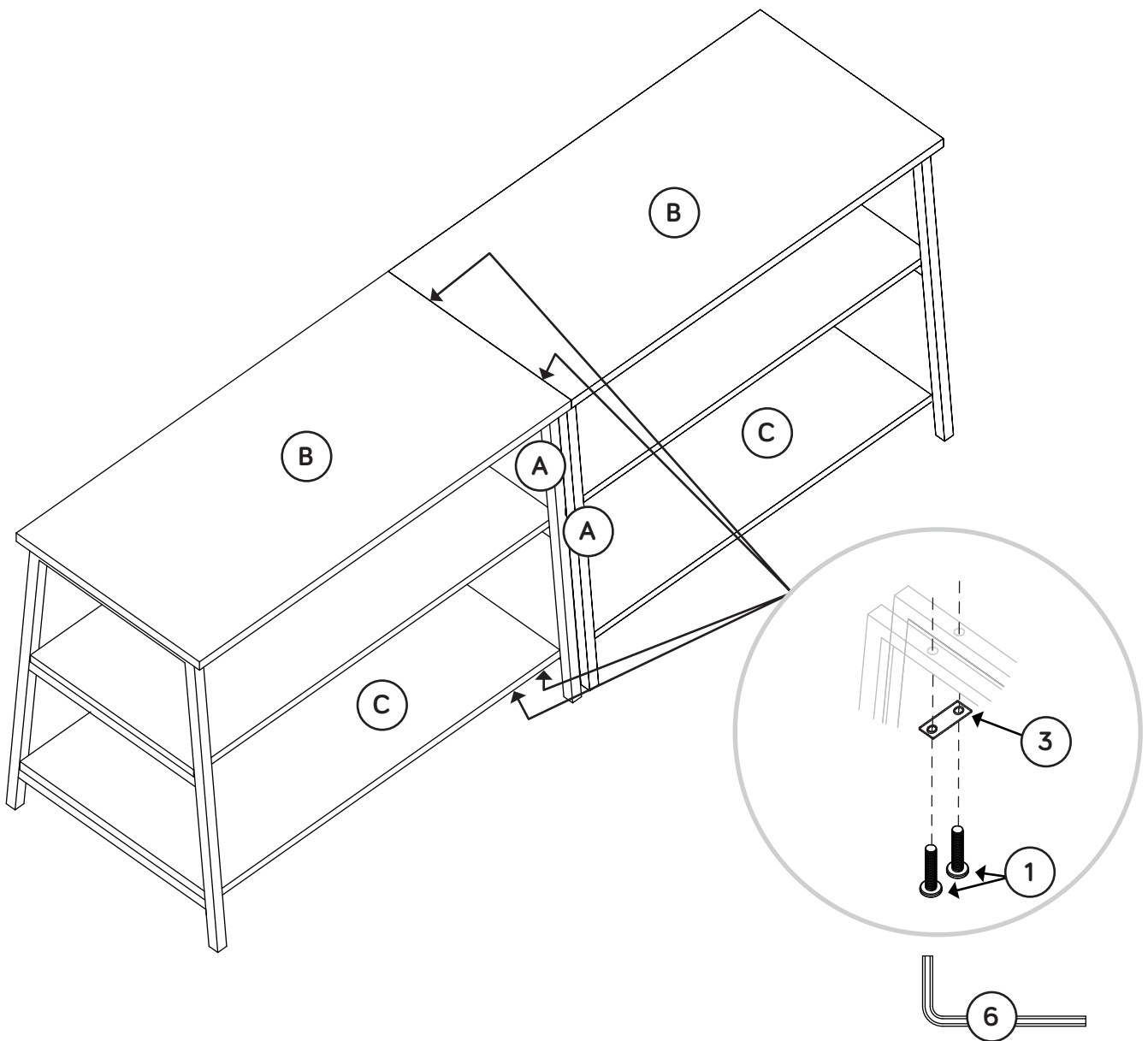

Step 6

Apply the WARNING LABEL (4) to the top of the single unit and the WARNING LABEL (5) to one of the two units if fastened together. You should be able to read the label when the TV is removed from the unit. When the TV is in place, it should hide the label. Peel off the backing and apply the label as shown in the diagram.

NOTE: This is a permanent label intended to last for the life of the product. Once applied, do not try to remove it.

NOTE: Please read the back pages of the instruction booklet for important safety information.

This completes assembly. Clean with your favorite furniture polish or a damp cloth. Wipe dry.

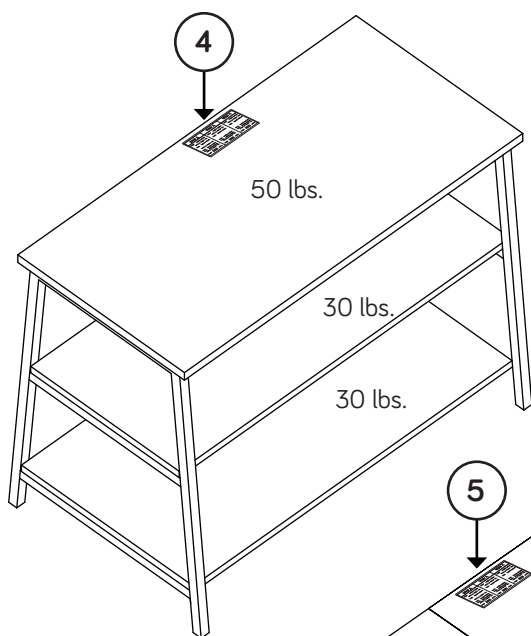

⚠ WARNING • ADVERTENCIA • AVERTISSEMENT ⚠		
<p>Never use this furniture with a TV that is too large or too heavy. Severe injury or death can occur. The TV and furniture will be unstable and may tip.</p> <p>-The TV must weigh less than 50 lbs. -The base of the TV must be able to sit completely on this shelf.</p> <p>Refer to instruction book for complete safety information.</p> <p><i>Note: This is a <u>permanent</u> label. Do not try to remove. Surface will be damaged.</i></p>	<p>Nunca use este mueble con un televisor que es demasiado grande o demasiado pesado. Podría resultar en una lesión grave hasta fatal. El televisor y el mueble estarán inestables y pueden volcarse.</p> <p>-El televisor debe pesar 45,4 kg o menos. -La base del televisor debe poder colocarse completamente sobre este estante.</p> <p>Consulte el folleto de instrucciones para información completa sobre la seguridad.</p> <p><i>Nota: Esta etiqueta es <u>permanente</u>. No intente quitarla. Causará daño a la superficie.</i></p>	<p>Ne jamais utiliser ce meuble avec un téléviseur qui soit trop large ou trop lourd. Risque de provoquer des blessures graves, voire mortelles. Le téléviseur et le meuble seront instables et risquent de se renverser.</p> <p>-Le téléviseur doit peser 45,4 kg ou moins. -Le socle du téléviseur doit pouvoir être placé complètement sur cette tablette.</p> <p>Consulter le manuel d'instructions pour information complète concernant la sécurité.</p> <p><i>Remarque: Cette étiquette est <u>permanente</u>. Ne pas essayer de la retirer. Causera des dommages à la surface.</i></p>

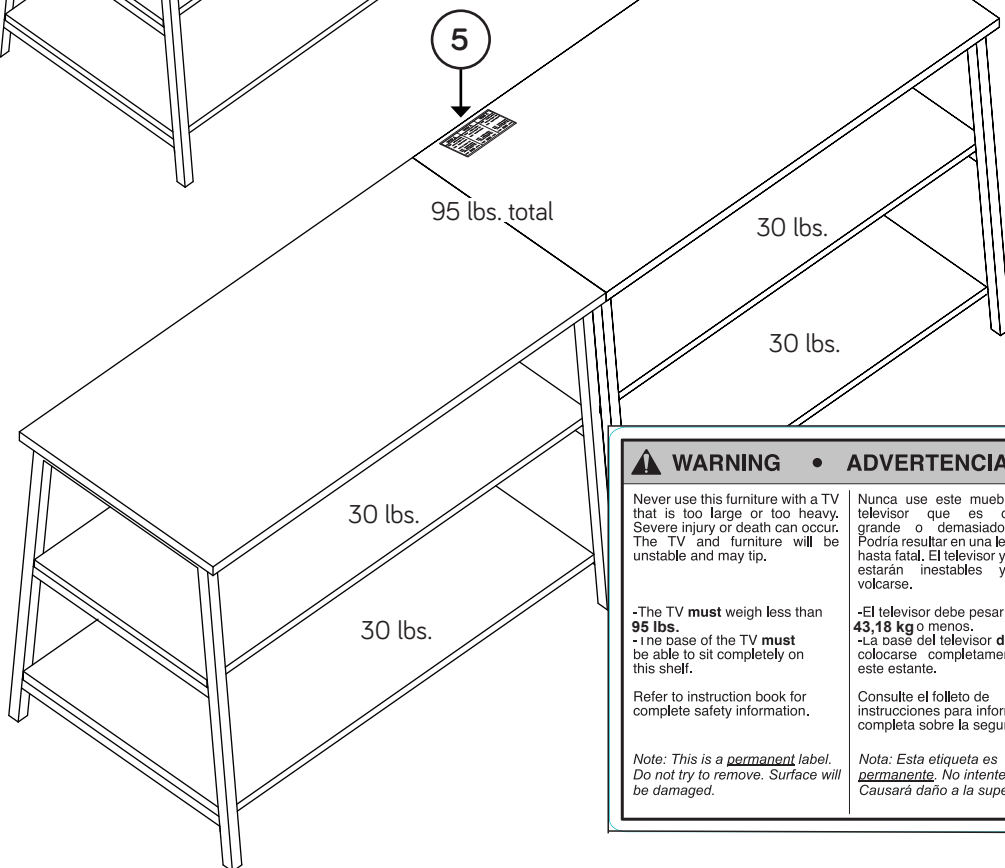

⚠ WARNING • ADVERTENCIA • AVERTISSEMENT ⚠		
<p>Never use this furniture with a TV that is too large or too heavy. Severe injury or death can occur. The TV and furniture will be unstable and may tip.</p> <p>-The TV must weigh less than 95 lbs. -The base of the TV must be able to sit completely on this shelf.</p> <p>Refer to instruction book for complete safety information.</p> <p><i>Note: This is a <u>permanent</u> label. Do not try to remove. Surface will be damaged.</i></p>	<p>Nunca use este mueble con un televisor que es demasiado grande o demasiado pesado. Podría resultar en una lesión grave hasta fatal. El televisor y el mueble estarán inestables y pueden volcarse.</p> <p>-El televisor debe pesar 43,18 kg o menos. -La base del televisor debe poder colocarse completamente sobre este estante.</p> <p>Consulte el folleto de instrucciones para información completa sobre la seguridad.</p> <p><i>Nota: Esta etiqueta es <u>permanente</u>. No intente quitarla. Causará daño a la superficie.</i></p>	<p>Ne jamais utiliser ce meuble avec un téléviseur qui soit trop large ou trop lourd. Risque de provoquer des blessures graves, voire mortelles. Le téléviseur et le meuble seront instables et risquent de se renverser.</p> <p>-Le téléviseur doit peser 43,18 kg ou moins. -Le socle du téléviseur doit pouvoir être placé complètement sur cette tablette.</p> <p>Consulter le manuel d'instructions pour information complète concernant la sécurité.</p> <p><i>Remarque: Cette étiquette est <u>permanente</u>. Ne pas essayer de la retirer. Causera des dommages à la surface.</i></p>

⚠ WARNING

Please use your furniture correctly and safely. Improper use can cause safety hazards, or damage to your furniture or household items. Carefully read the following safety information.

Death or serious injury may occur when children climb on audio and/or video equipment furniture. A remote control or toys placed on the furnishing may encourage a child to climb on the furnishing and as a result may tip over onto the child.

NEVER allow children to climb or play with the TV or furnishing supporting the TV.

NEVER place toys, food, remote, etc. on top of the TV or TV furnishing.

ALWAYS use either the safety hardware as instructed or other wall anchoring device.

Relocating audio and/or video equipment to furniture not specifically designed to support audio and/or video equipment may result in death or serious injury due to furniture collapse or over turning onto a child.

NEVER place a TV on furniture that is not intended to support a TV.

NEVER exceed the maximum size and weight of the TV shown in the instructions.

Be sure to apply the TV warning label as shown in the instructions.

Overloading drawers and shelves may result in furniture that can break or sag, or tip-over which may result in injury.

NEVER exceed the weight limits shown in the instructions.

Place the heavier items on lower shelves as far back from the front as possible.

Load the bottom surfaces first to avoid top-heavy furniture.

Moving furniture that is not designed to be moved or equipped with casters may result in injury or damage to furnishings or personal property.

ALWAYS unload shelves and drawers, starting with the top surfaces, before moving.

NEVER push or pull furniture on carpet. Have a friend help lift properly to move and/or reposition it.