

INSTRUCTION MANUAL

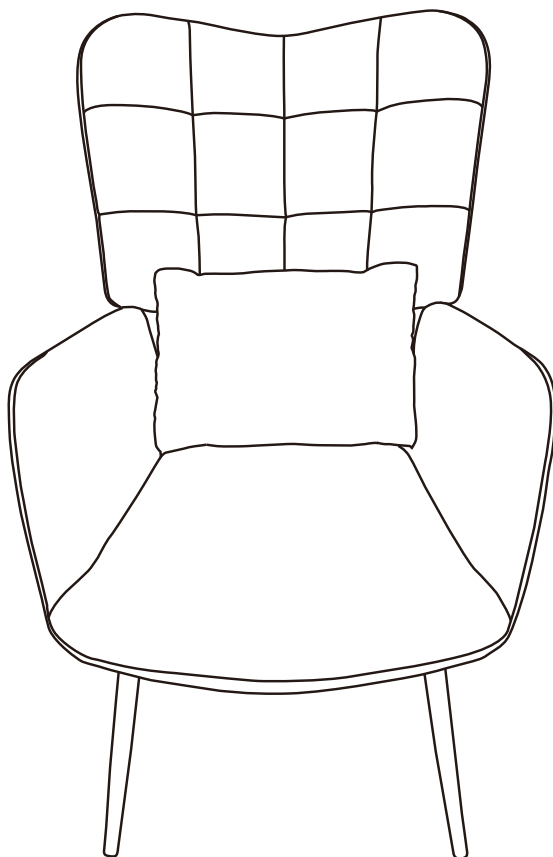

Please check that all parts are in good condition before assembling.
If any aren't, hold off assembling the product and contact us straight away so we can resolve this for you.

- Make sure you have all the parts listed in the instruction.
- Assemble step by step and follow the instructions.
- Assemble on a soft mat to avoid any scratches.
- Periodically check and tighten screws where necessary.

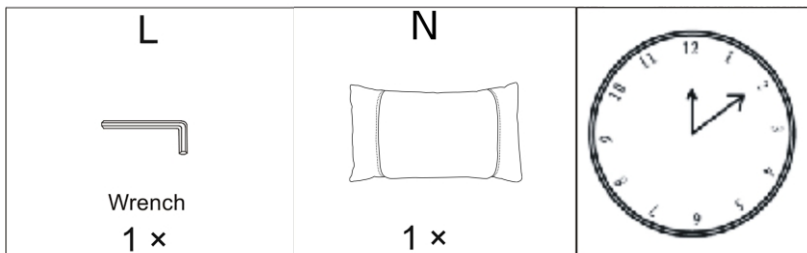
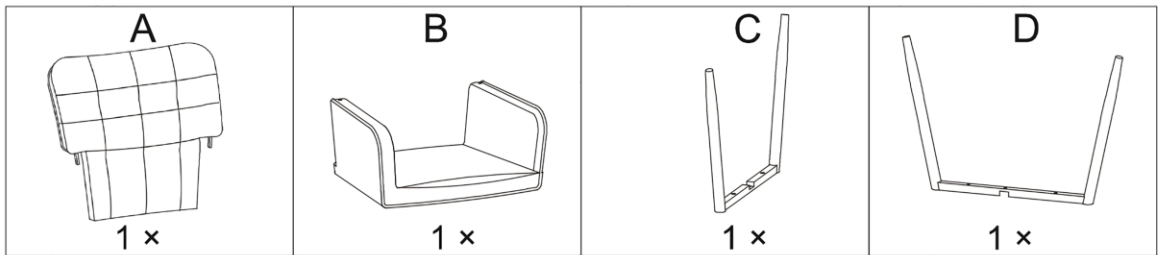

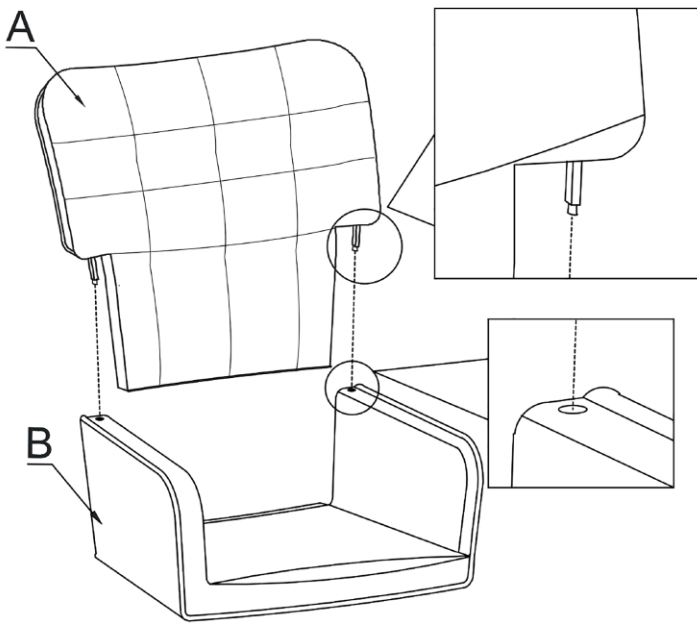

- Insert the metal bars on the Back A into the pre-drilled holes on the Arms on Seat B as indicated in above step.

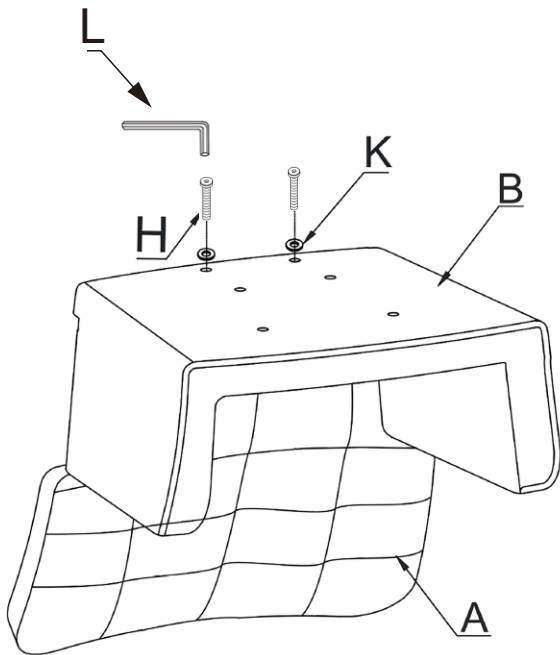

- Insert the Screws H into the holes on the Seat Bottom B and Back A. Secured with Allen Wrench L. Tighten the screws.

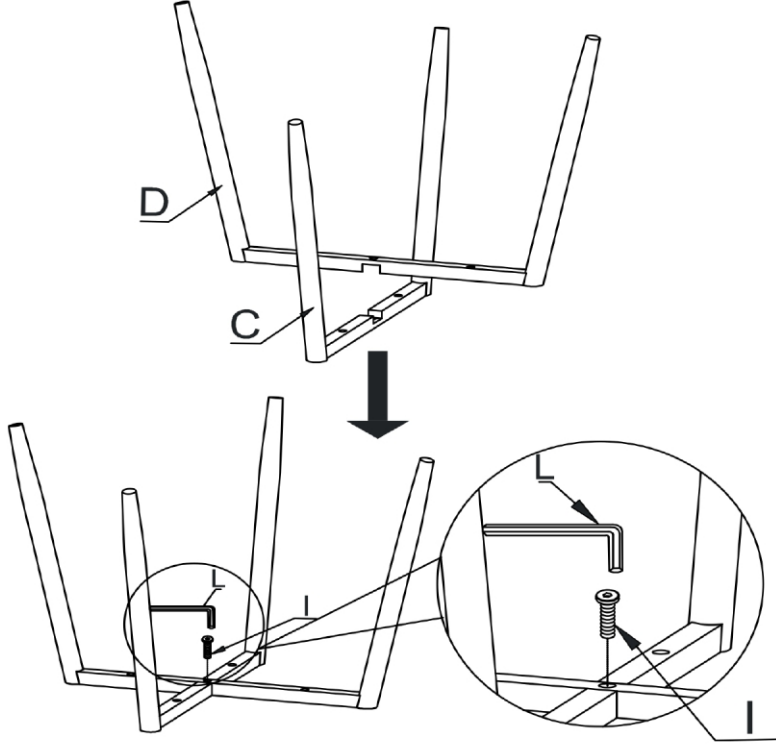

- Assemble Leg C and Leg D and secured with Screws I and Allen Wrench L.

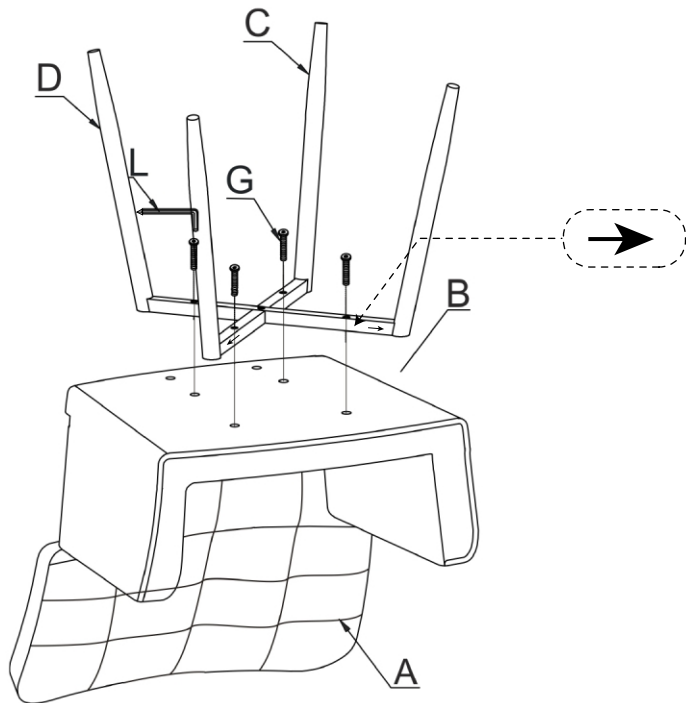

- Attaching Legs C & D to Seat Bottom B. Secured with Screws G and Allen Wrench L. Tighten all the screws.

