

Installation & Assembly

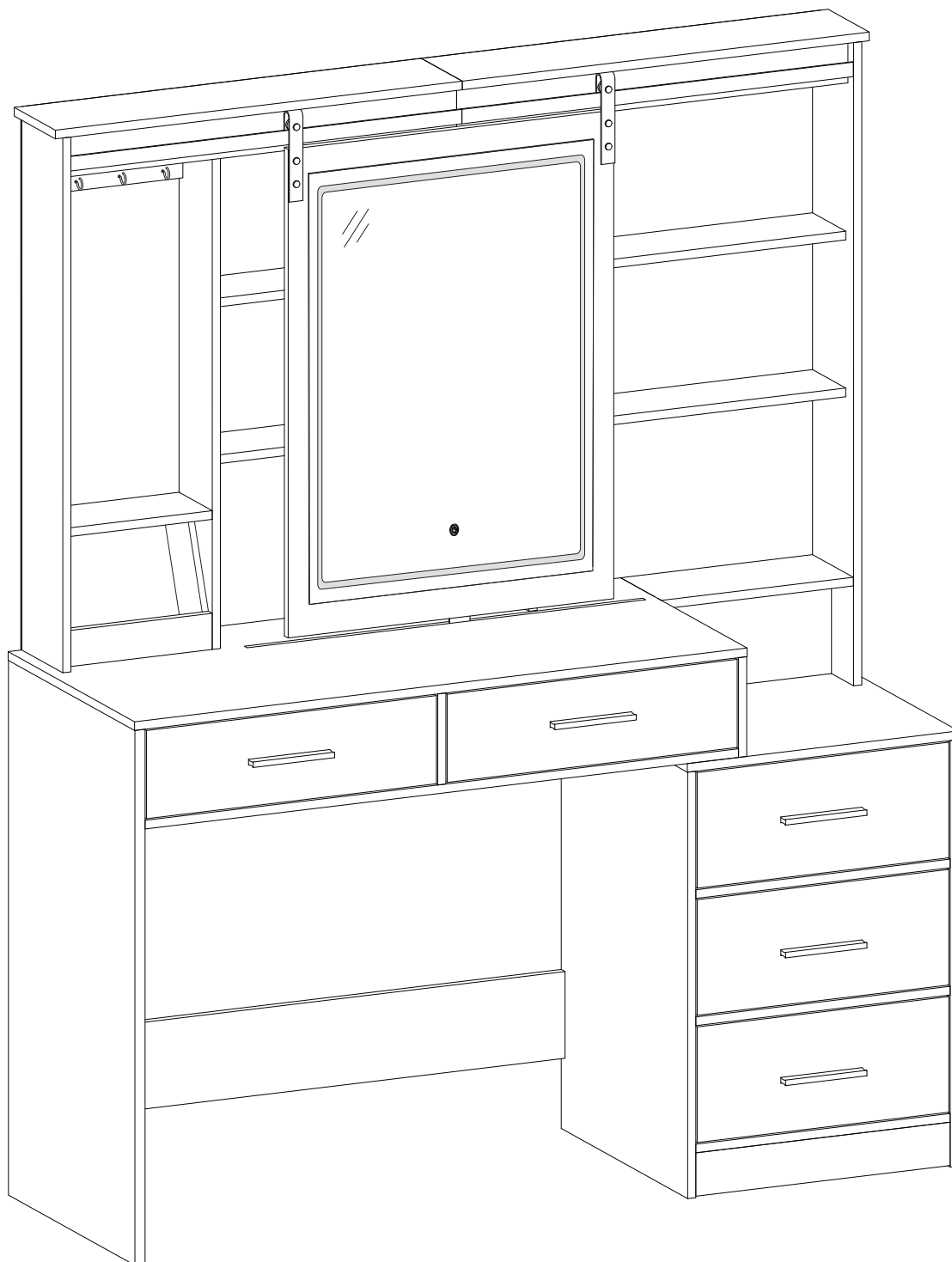

EN

General Guidelines

Please read the following instruction carefully and use the product accordingly.
Please keep this manual and hand it over when you transfer the product.
This summary may not include every detail of all variations and considered steps.
Please contact us when further information and help are needed.

Notes

The product is intended for indoor use only. The product must be assembled and use in accordance with the provisions of the manual. Personal injury and/or damage to product may occur if products are used outside of their intended purposes and/or if products have been changed/modified from their original design. The seller does not assume any responsibility or liability with respect to any injury/damage caused by incorrect assembly or improper use.

Avoid long-term exposure to humid environments to prevent mildew.

Keep the product away from fire sources and high temperatures. Do not expose the product to direct sunlight.

Do not place any hot objects on the surface of the product.

If there are any defective or missing parts after unpacking, please cease assembly immediately and contact us.

Please assemble the item on a spacious surface and do not place the unwrapped product directly on the ground to avoid product damage.

Please do not stand or sit on the wooden boards.

Please wear gloves during the assembly and/or disassembly process to avoid scratches from any sharp edges.

Please match the corresponding part and fitting based on the part number in the manual.

If the part does not match with the fitting, please check the piece as specified in this manual.

During assembly, first loosely align all screws with the corresponding pre-drilled holes and then tighten the screws one by one.

Periodically inspect screw tightness while the product is in use. If necessary, retighten to ensure structural integrity.

If you accidentally spill water or another liquid on the surface, immediately wipe clean with a dry towel.

Please keep the product away from sharp, pointed objects and corrosive substances to prevent product damage.

Please place this item on level, solid ground during use.

Warnings

Children are not allowed to assemble the product. During assembly, keep all any small parts out of the reach of children as they may be fatal if swallowed or inhaled.

Children are forbidden to climb or play on the product to avoid serious bodily injury caused by the toppling.

Keep plastic packing bags out of reach of children to avoid any potential danger, such as suffocation.

The maximum static load capacity of the product is 100 kg (220lb). Do not place overweight items on it.

DE

Allgemeine Hinweise

Bitte lesen Sie die folgende Anleitung sorgfältig durch und verwenden Sie das Produkt entsprechend.
Bitte bewahren Sie diese Anleitung auf und geben Sie sie bei der Übergabe des Produkts weiter.
Diese Zusammenfassung kann nicht alle Einzelheiten aller Varianten und zu beachtenden Schritte enthalten.
Bitte kontaktieren Sie uns, wenn Sie weitere Informationen und Hilfe benötigen.

Hinweise

Das Produkt ist nur für den Gebrauch in Innenräumen bestimmt. Das Produkt muss in Übereinstimmung mit den Bestimmungen des Handbuchs aufgebaut und verwendet werden. Es kann zu Verletzungen und/oder Schäden am Produkt kommen, wenn das Produkt außerhalb seiner Zweckbestimmung verwendet wird und/oder wenn das Produkt abweichend von seinem ursprünglichen Design geändert/modifiziert wurde. Der Verkäufer übernimmt keine Verantwortung oder Haftung in Bezug auf Verletzungen/Schäden, die durch falsche Montage oder unsachgemäßen Gebrauch verursacht werden.

Vermeiden Sie es, das Produkt längere Zeit feuchten Umgebungen auszusetzen, um Schimmel zu vermeiden.

Halten Sie das Produkt von Feuerquellen und hohen Temperaturen fern. Setzen Sie das Produkt nicht direktem Sonnenlicht aus.

Stellen Sie keine heißen Gegenstände auf die Oberfläche des Produkts.

Sollten nach dem Auspacken Teile fehlen oder defekt sein, unterbrechen Sie bitte sofort den Aufbau und kontaktieren Sie uns.

Bitte bauen Sie den Artikel auf einer geräumigen Fläche auf und stellen Sie das ausgepackte Produkt nicht direkt auf den Boden, um Produktschäden zu vermeiden.

Bitte stehen oder sitzen Sie nicht auf den Holzbrettern.

Bitte tragen Sie während der Montage und/oder Demontage Handschuhe, um Kratzer durch scharfe Kanten zu vermeiden.

Achten Sie darauf, dass Sie das entsprechende Teil und den passenden Anschluss anhand der Teilenummer in der Anleitung finden.

Wenn das Teil nicht mit dem Beschlag übereinstimmt, überprüfen Sie bitte das Teil wie in dieser Anleitung angegeben.

Richten Sie beim Zusammenbau zunächst alle Schrauben locker auf die entsprechenden vorgebohrten Löcher aus und ziehen Sie dann die Schrauben nacheinander fest.

Überprüfen Sie regelmäßig den festen Sitz der Schrauben, während das Produkt in Gebrauch ist. Ziehen Sie sie bei Bedarf nach, um die strukturelle Integrität zu gewährleisten.

Wenn Sie versehentlich Wasser oder eine andere Flüssigkeit auf die Oberfläche verschüttet haben, wischen Sie sie sofort mit einem trockenen Handtuch ab.

Bitte halten Sie das Produkt von scharfen, spitzen Gegenständen und ätzenden Substanzen fern, um Schäden am Produkt zu vermeiden.

Bitte stellen Sie das Gerät während der Benutzung auf einen ebenen, festen Untergrund.

Warnhinweise

Kinder dürfen das Produkt nicht zusammenbauen. Bewahren Sie während der Montage alle Kleinteile außerhalb der Reichweite von Kindern auf, da sie bei Verschlucken oder Einatmen tödlich sein können.

Kinder dürfen nicht auf das Produkt klettern oder darauf spielen, um schwere Körperverletzungen durch Umkippen zu vermeiden.

Bewahren Sie Plastikverpackungsbeutel außerhalb der Reichweite von Kindern auf, um mögliche Gefahren, wie z. B. Erstickungsgefahr, zu vermeiden.

Die maximale statische Belastbarkeit des Produkts beträgt 100 kg (220 lb). Don 't platzieren Sie übergewichtige Gegenstände darauf.

FR

Lignes directrices

Veillez lire attentivement les instructions suivantes et utiliser le produit en conséquence.
Conservez ce manuel et remettez-le lors du transfert du produit.
Ce résumé peut ne pas inclure tous les détails de toutes les variantes et étapes envisagées.
N'hésitez pas à nous contacter si vous avez besoin de plus d'informations et d'aide.

Notes

Le produit est destiné à être utilisé à l'intérieur uniquement. Le produit doit être assemblé et utilisé conformément aux dispositions du manuel. Des blessures corporelles et/ou des dommages au produit peuvent survenir si les produits sont utilisés en dehors de leur usage prévu et/ou si le produit n'est pas utilisé conformément à sa destination. Les produits ont été changés/modifiés par rapport à leur conception d'origine. Le vendeur n'assume aucune responsabilité en ce qui concerne les blessures/dommages causés par un assemblage incorrect ou une utilisation inadéquate. Éviter l'exposition prolongée à des environnements humides pour éviter la formation de moisissures. Tenir le produit à l'écart des sources de feu et des températures élevées. Ne pas exposer le produit à la lumière directe du soleil. Ne pas placer d'objets chauds sur la surface du produit. Si des pièces sont défectueuses ou manquantes après le déballage, veuillez cesser immédiatement l'assemblage et nous contacter. Veuillez assembler l'article sur une surface spacieuse et ne pas placer le produit déballé directement sur le sol afin d'éviter de l'endommager. Il est interdit de se tenir debout ou de s'asseoir sur les planches en bois. Veuillez porter des gants pendant le processus de montage et/ou de démontage afin d'éviter les éraflures dues aux arêtes vives. Veuillez trouver la pièce et le raccord correspondants en vous basant sur le numéro de pièce figurant dans le manuel. Si la pièce ne correspond pas au raccord, veuillez vérifier la pièce comme indiqué dans ce manuel. Lors de l'assemblage, alignez d'abord légèrement toutes les vis avec les trous préperçés correspondants, puis serrez les vis une par une. Vérifier périodiquement le serrage des vis pendant l'utilisation du produit. Si nécessaire, resserrez les vis pour garantir l'intégrité de la structure. Si vous renversez accidentellement de l'eau ou un autre liquide sur la surface, essuyez-la immédiatement avec une serviette sèche. Pour éviter d'endommager le produit, il convient de le tenir à l'écart des objets pointus et tranchants ainsi que des substances corrosives. Placez l'appareil sur un sol plat et solide pendant l'utilisation.

Avertisse

Les enfants ne sont pas autorisés à assembler le produit. Pendant l'assemblage, gardez toutes les petites pièces hors de portée des enfants, car elles peuvent être mortelles si elles sont avalées ou inhalées. Il est interdit aux enfants de grimper ou de jouer sur le produit afin d'éviter les blessures corporelles graves causées par le basculement. Conservez les sacs d'emballage en plastique hors de portée des enfants afin d'éviter tout danger potentiel, tel que la suffocation. La capacité de charge statique maximale du produit est de 100 kg (220 lb). Ne placez pas d'articles en surpoids dessus.

IT

Linee guida

Leggere attentamente le istruzioni che seguono e usare il prodotto di conseguenza.
Si prega di tenere questo manuale e consegnarlo quando si smonta il prodotto.
Questa sintesi può non includere tutti i dettagli di tutte le variazioni e di tutte le fasi considerate.
Vi prego di contattarci qualora siano necessarie ulteriori informazioni e assistenza.

Note

Il prodotto è destinato esclusivamente all'uso interno. Il prodotto deve essere assemblato e utilizzato in conformità alle disposizioni del manuale.

Se il prodotto viene utilizzato per scopi diversi per cui è stato concepito e/o se viene utilizzato per scopi diversi da quelli per cui è stato concepito, possono verificarsi lesioni e/o danni al prodotto. I prodotti sono stati cambiati/modificati rispetto al progetto originale. Non si assume alcuna responsabilità per eventuali lesioni/danni causati da un montaggio non corretto o da un uso improprio.

Evitare l'esposizione prolungata ad ambienti umidi per prevenire la muffa.
Tenere il prodotto lontano da fonti di incendio e da temperature elevate.
Non esporre il prodotto alla luce diretta del sole.
Non collocare oggetti caldi sulla superficie del prodotto. Se dopo il disimballaggio si riscontrano parti difettose o mancanti, si interrompere immediatamente il montaggio e contattarci.

Si prega di assemblare l'articolo su una superficie spaziosa e di non appoggiare il prodotto non imballato direttamente a terra per evitare di danneggiare il prodotto.

Si prega di non stare in piedi o seduti sulle tavole di legno. Indossare i guanti durante il processo di montaggio e/o smontaggio per evitare graffi dovuti a spigoli vivi.

Si prega di abbinare il componente e il raccordo corrispondente in base al numero di parte del manuale.

Se il pezzo non corrisponde al raccordo, controllare il pezzo come specificato in questo manuale.

Durante l'assemblaggio, allineare prima tutte le viti con i fori corrispondenti e poi serrarle una per una. Controllare periodicamente il serraggio delle viti mentre il prodotto è in uso.

Se necessario, serrare nuovamente per garantire l'integrità strutturale. Se si rovescia accidentalmente dell'acqua o un altro liquido sulla superficie, pulire immediatamente con un panno asciutto.

Tenere il prodotto lontano da oggetti appuntiti e taglienti e da sostanze corrosive per evitare danni al prodotto.

Durante l'uso, collocare il prodotto su un terreno piano e solido.

Avvertimento

I bambini non possono assemblare il prodotto.

Durante l'assemblaggio, tenere tutti i piccoli componenti fuori dalla portata dei bambini, poiché possono essere fatali se ingeriti o inalati.

Ai bambini è vietato arrampicarsi o giocare sul prodotto per evitare gravi lesioni fisiche causate dal ribaltamento.

Tenere i sacchetti di plastica dell'imballaggio fuori dalla portata dei bambini per evitare potenziali pericoli, come il soffocamento. La capacità massima di carico statico del prodotto è di 100 kg (220 lb).

Non mettere elementi in sovrappeso su di esso.

ES

Directrices

Lea atentamente las siguientes instrucciones y utilice el producto de acuerdo con ellas. Conserve este manual y entréguelo cuando transfiera el producto. Es posible que este resumen no incluya todos los detalles de todas las variantes y pasos considerados. Póngase en contacto con nosotros cuando necesite más información y ayuda.

Notas

Este producto es sólo para uso interior. El producto debe ser montado y utilizado de acuerdo con las regulaciones de acuerdo con el manual. Lesiones personales y/o daños al producto pueden ocurrir si el producto está dañado o se utiliza fuera de su uso previsto y/o el producto no se utiliza de acuerdo con su uso previsto. El producto ha sido cambiado/modificado de su diseño original.

El vendedor no se hace responsable de las lesiones/daños causados por la empresa de montaje.

Uso correcto o inapropiado. Evite la exposición prolongada a la humedad, evite el moho y mantenga el producto lejos de fuentes de ignición y altas temperaturas. No exponer el producto a la luz solar directa.

No coloque objetos calientes en la superficie del producto. Piezas defectuosas o faltantes después de abrir la caja.

Por favor, detenga el montaje y contáctenos inmediatamente. Por favor, monte el artículo en una superficie espaciosa.

No coloque la luz sin encender directamente en el piso, para evitar el 'endommager'. Está prohibido pararse o sentarse en la tabla, por favor use guantes. Proceso de montaje y/o desmontaje para evitar arañazos en los bordes afilados.

Por favor, encuentre la pieza adecuada y la conexión de acuerdo con el número de pieza en el manual.

Si las piezas no coinciden con los accesorios, compruebe por favor las piezas en este manual.

Al ensamblar, primero alinear suavemente todos los tornillos con el agujero previo correspondiente y luego apretar el tornillo por tornillo. Verifique periódicamente que los tornillos estén bien apretados al usar el producto. Si es necesario, apriete los tornillos para asegurar la integridad estructural.

Si usted derramó accidentalmente agua u otro líquido en la superficie, limpie inmediatamente con una toalla seca.

Para evitar dañar el producto, debe mantenerse alejado de objetos puntiagudos y sustancias corrosivas.

Cuando esté en uso, coloque el dispositivo en una tierra plana y firme.

Advertencia

Los niños no pueden montar este producto. Mantenga todas las piezas pequeñas fuera del alcance de los niños durante la ensamblaje, porque si se ingieren o inhalan.

Se prohíbe que los niños escalen o jueguen con este producto para evitar el vertido causa lesiones corporales graves. Mantenga las bolsas de plástico fuera del alcance para evitar cualquier peligro potencial, como la asfixia. Capacidad de carga estática máxima del producto es de 100 kg (220 libras).

No coloque objetos con sobrepeso sobre ellos.

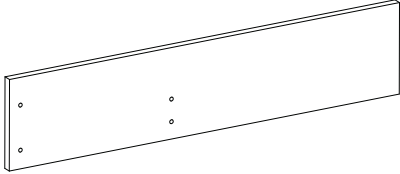
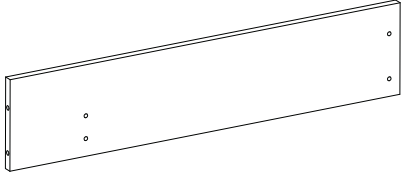
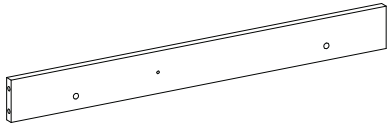
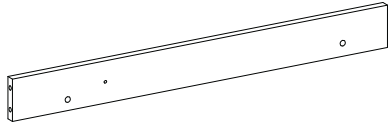
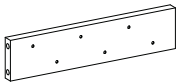
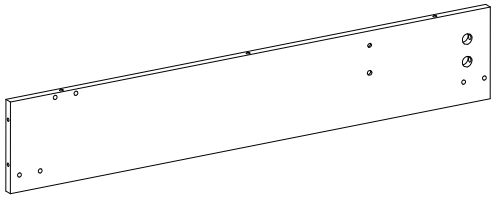
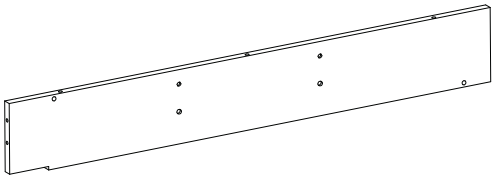
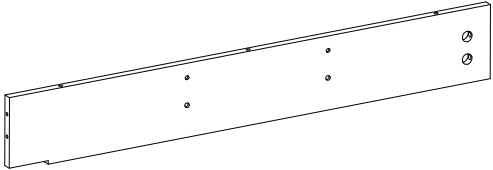
<p>A ×1</p> 	<p>B ×1</p> 
<p>C ×1</p> 	<p>D ×1</p> 
<p>E ×1</p> 	<p>F ×1</p> 
<p>G ×1</p> 	<p>H ×1</p> 

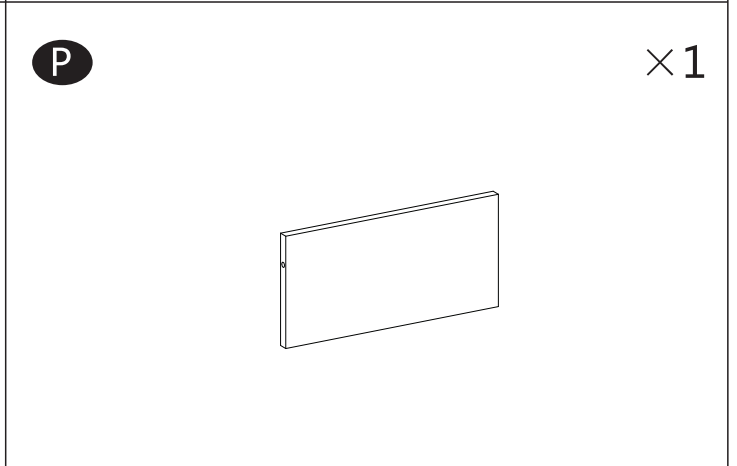
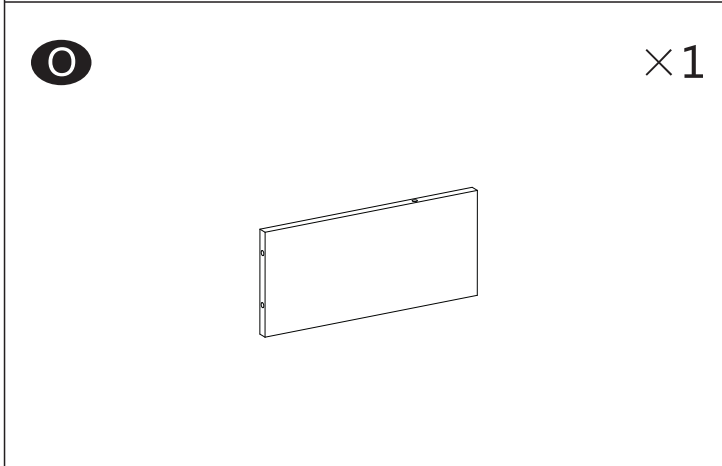
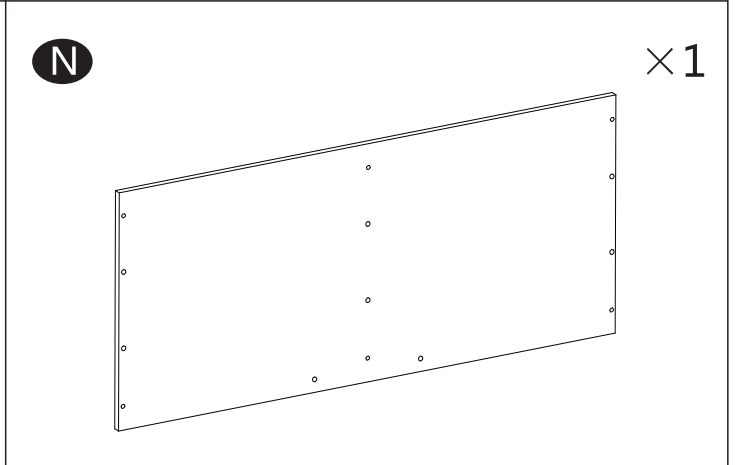
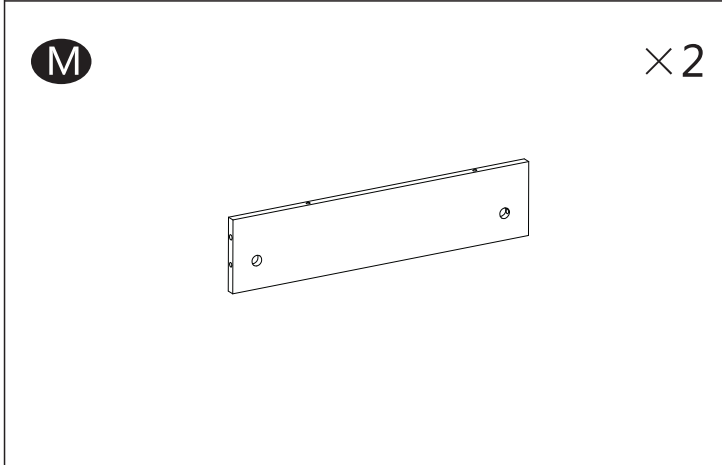
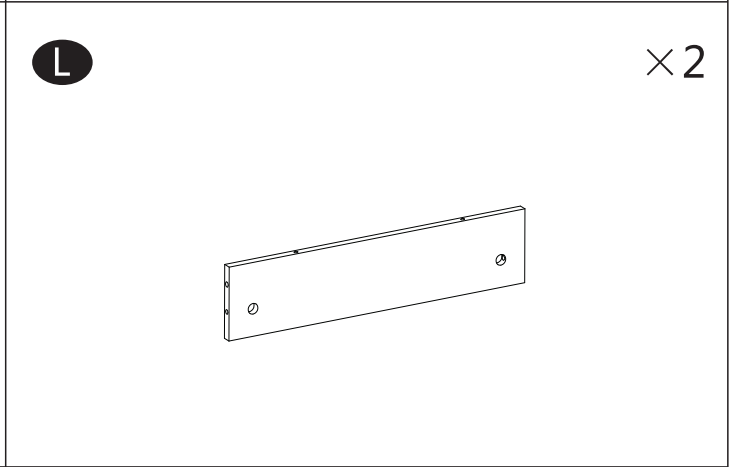
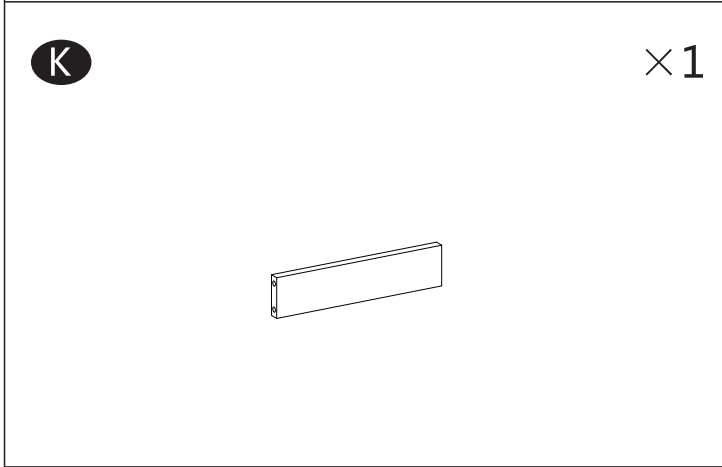
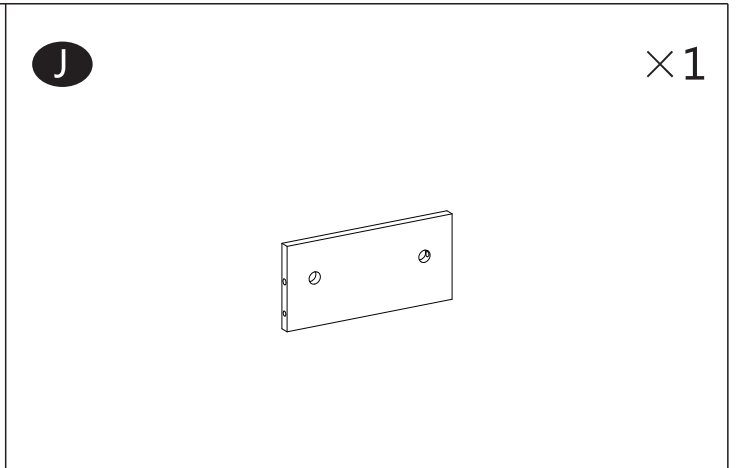
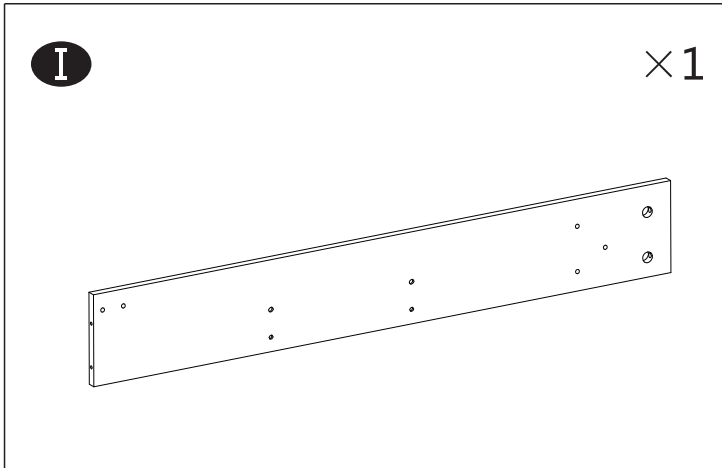

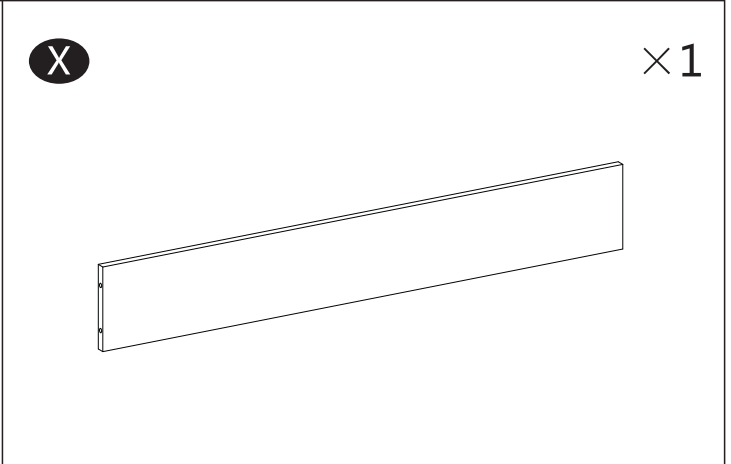
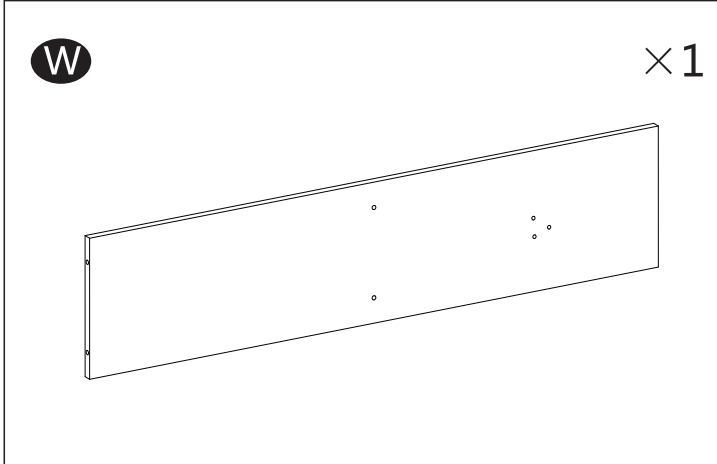
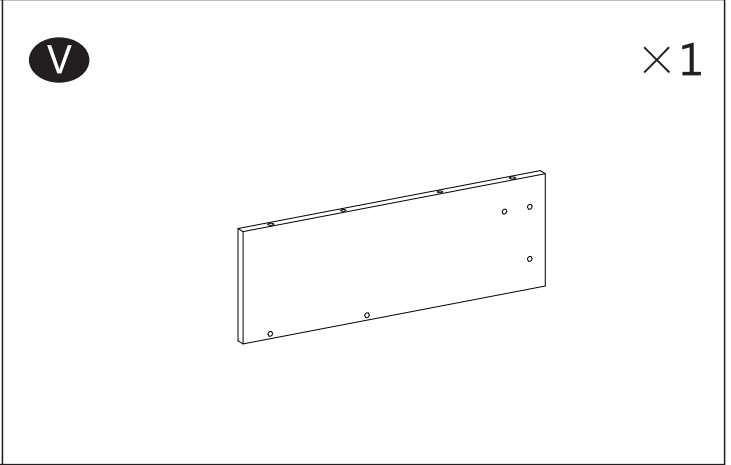
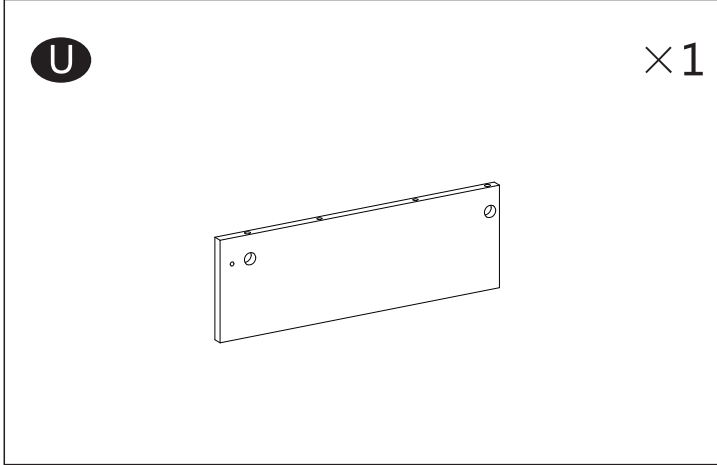
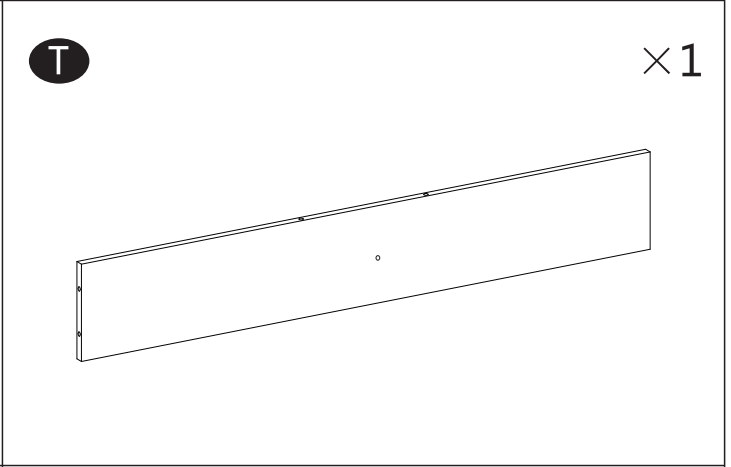
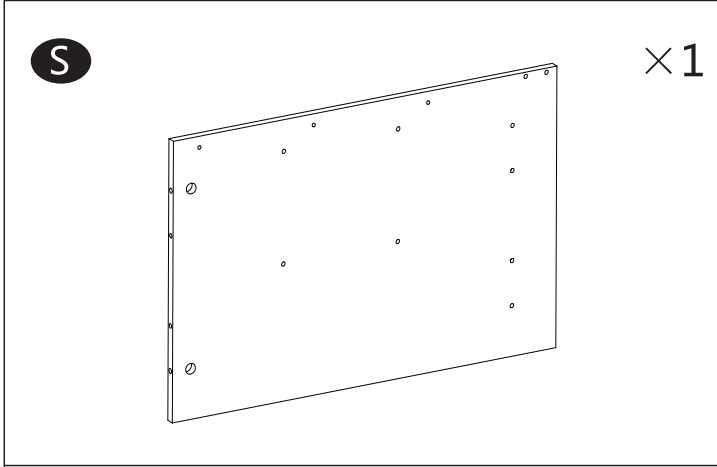
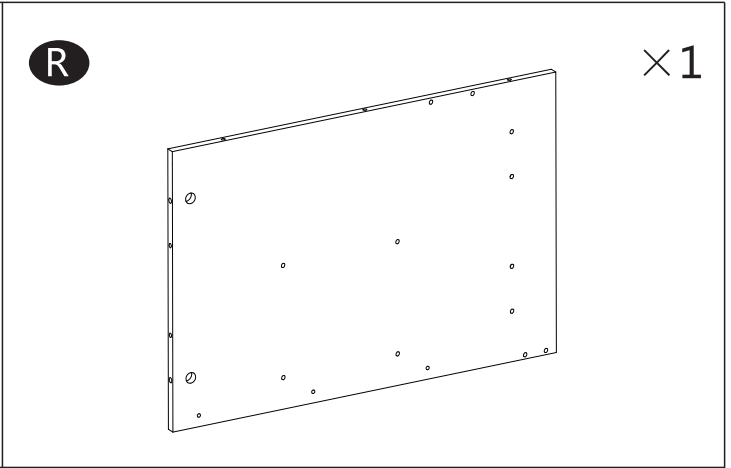
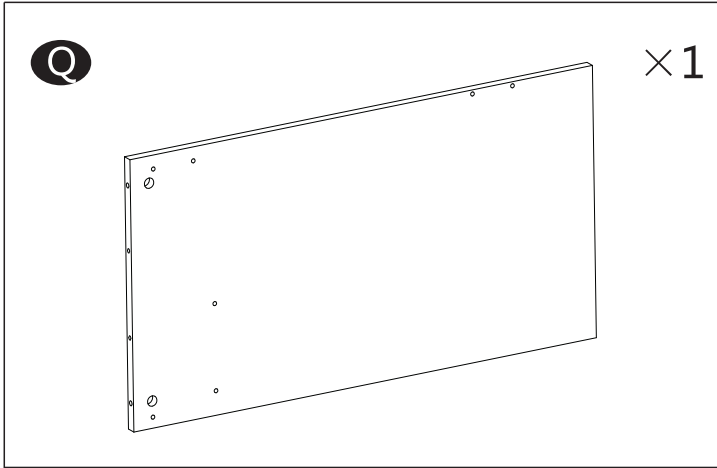

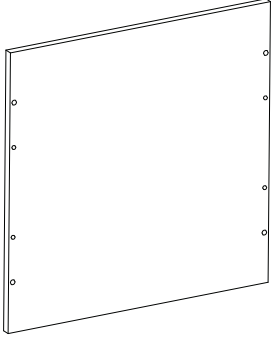
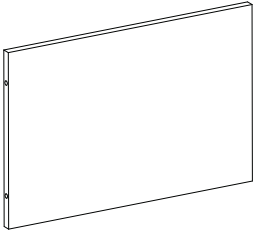
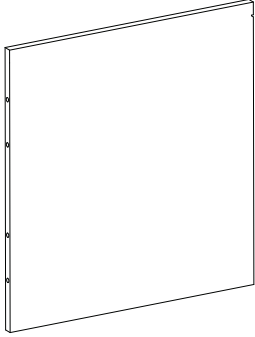
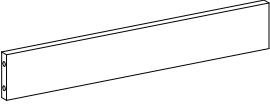
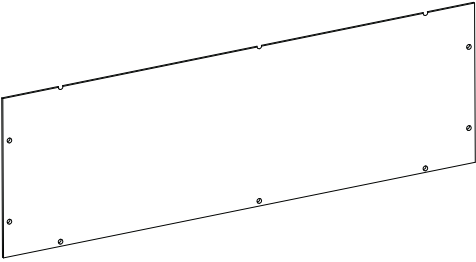
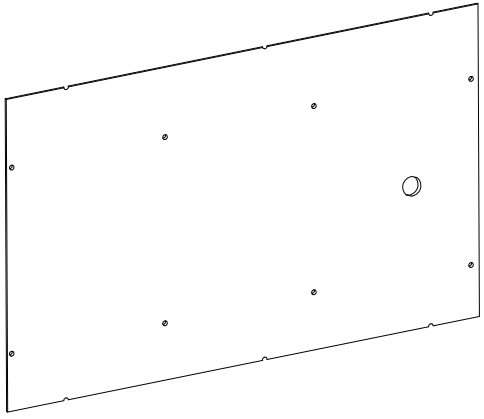
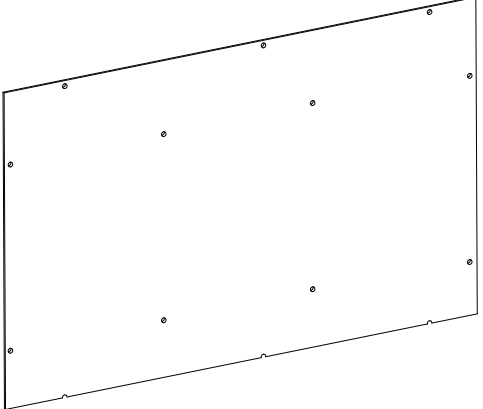
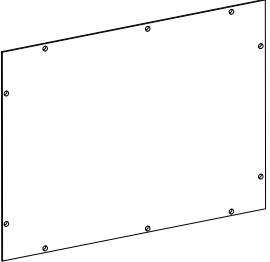
<p>Y ×1</p> 	<p>Z ×2</p> 
<p>AA ×1</p> 	<p>BB ×1</p> 
<p>CC ×1</p> 	<p>DD ×1</p> 
<p>EE ×1</p> 	<p>FF ×1</p> 

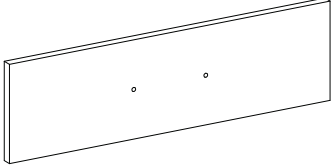
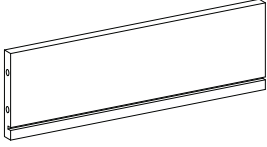
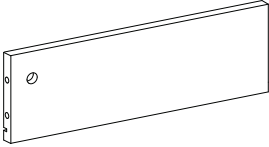
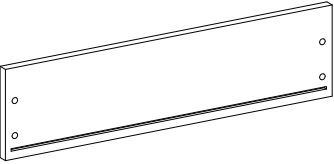
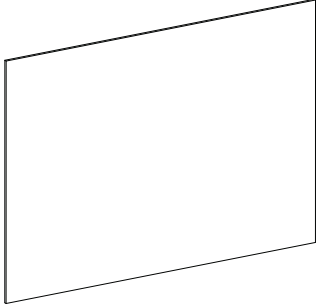
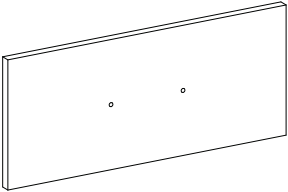
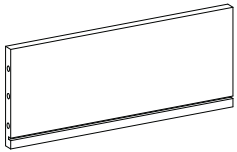
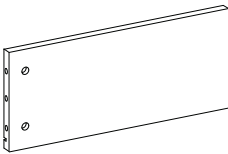

<p>GG ×2</p> 	<p>HH ×2</p> 
<p>II ×2</p> 	<p>JJ ×2</p> 
<p>KK ×2</p> 	<p>LL ×3</p> 
<p>MM ×3</p> 	<p>NN ×3</p> 

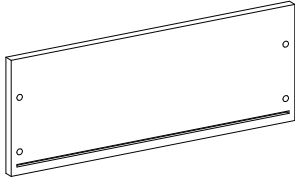
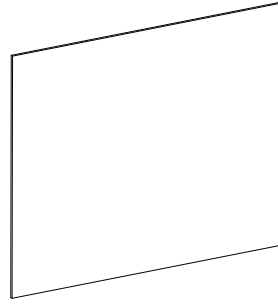
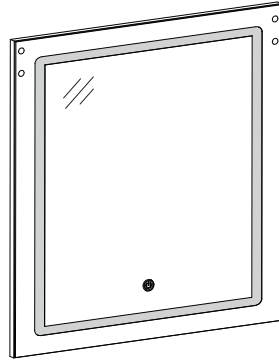
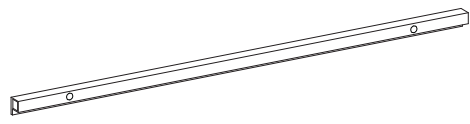
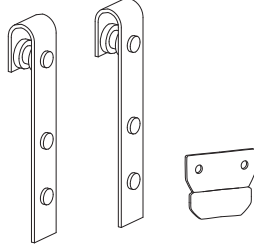
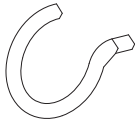
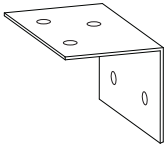
<p>OO ×3</p> 	<p>PP ×3</p> 
<p>QQ ×1</p> 	<p>RR ×2</p> 
	<p>TT ×1</p> 
<p>UU ×6</p> 	<p>VV ×1</p> 



×1

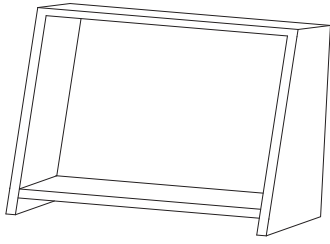

1

×47



Φ6 X 30 MM

6

×31

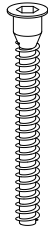

Φ5 X 40 MM

12

×7



M3 X 12 MM

13

×42



M3.5 X 12 MM

27

×42

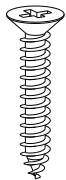

M4 X 35 MM

39

×8

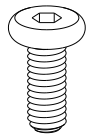

M6 X 16 MM

76

×44

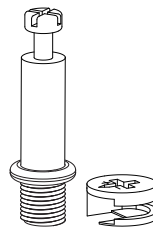

77

×1

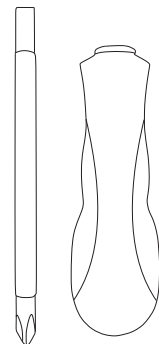

106

×2

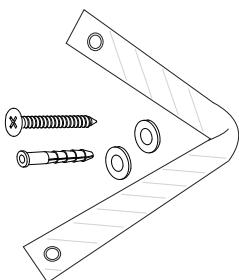

123

×1

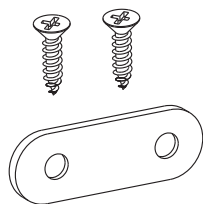

131

×1

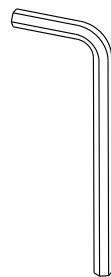

M3

132

×1

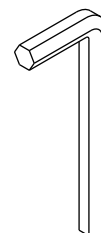

M4

139

×31



12MM

140

×12

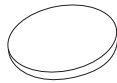

18MM

144

×6



166

×10

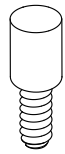

190

×5

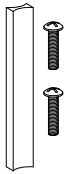

236

×1



EU

274

×1



UK

OR

Tips / Notes / Hinweise / Suggestimenti / Sugerencias

EN. If there is any damage after opening the box, or any problems during assembly, please contact us by email as soon as possible. Our customer service team provides professional return service and assembly instruction.

DE. Sollten nach dem Öffnen des Kartons Schäden oder Probleme bei der Montage auftreten, kontaktieren Sie uns bitte umgehend per E-Mail. Unser Kundendienstteam bietet einen professionellen Rückholservice und eine Montageanleitung.

FR. En cas de dommage après l'ouverture de la boîte ou de problème lors de l'assemblage, veuillez nous contacter par courrier électronique dans les plus brefs délais. Notre équipe de service à la clientèle fournit un service de retour professionnel et des instructions d'assemblage.

IT. In caso di danni dopo l'apertura della scatola o di problemi durante il montaggio, si prega di contattarci via e-mail al più presto. Il nostro servizio clienti fornisce un servizio di restituzione professionale e istruzioni di montaggio.

ES. Si se produce algún daño después de abrir la caja, o algún problema durante el montaje, póngase en contacto con nosotros por correo electrónico lo antes posible. Nuestro equipo de atención al cliente ofrece un servicio de devolución profesional e instrucciones de montaje.

Additional tools required:

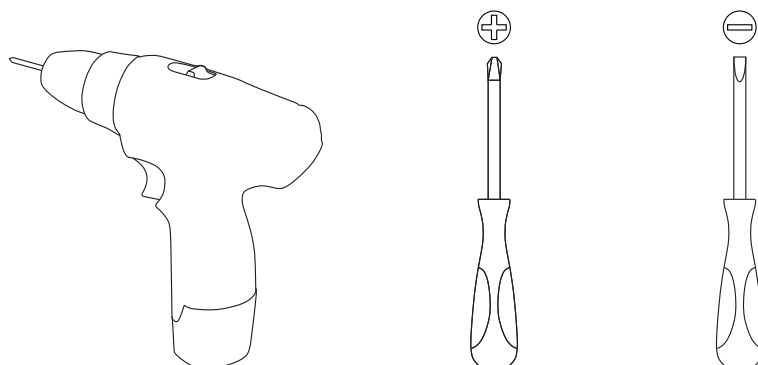

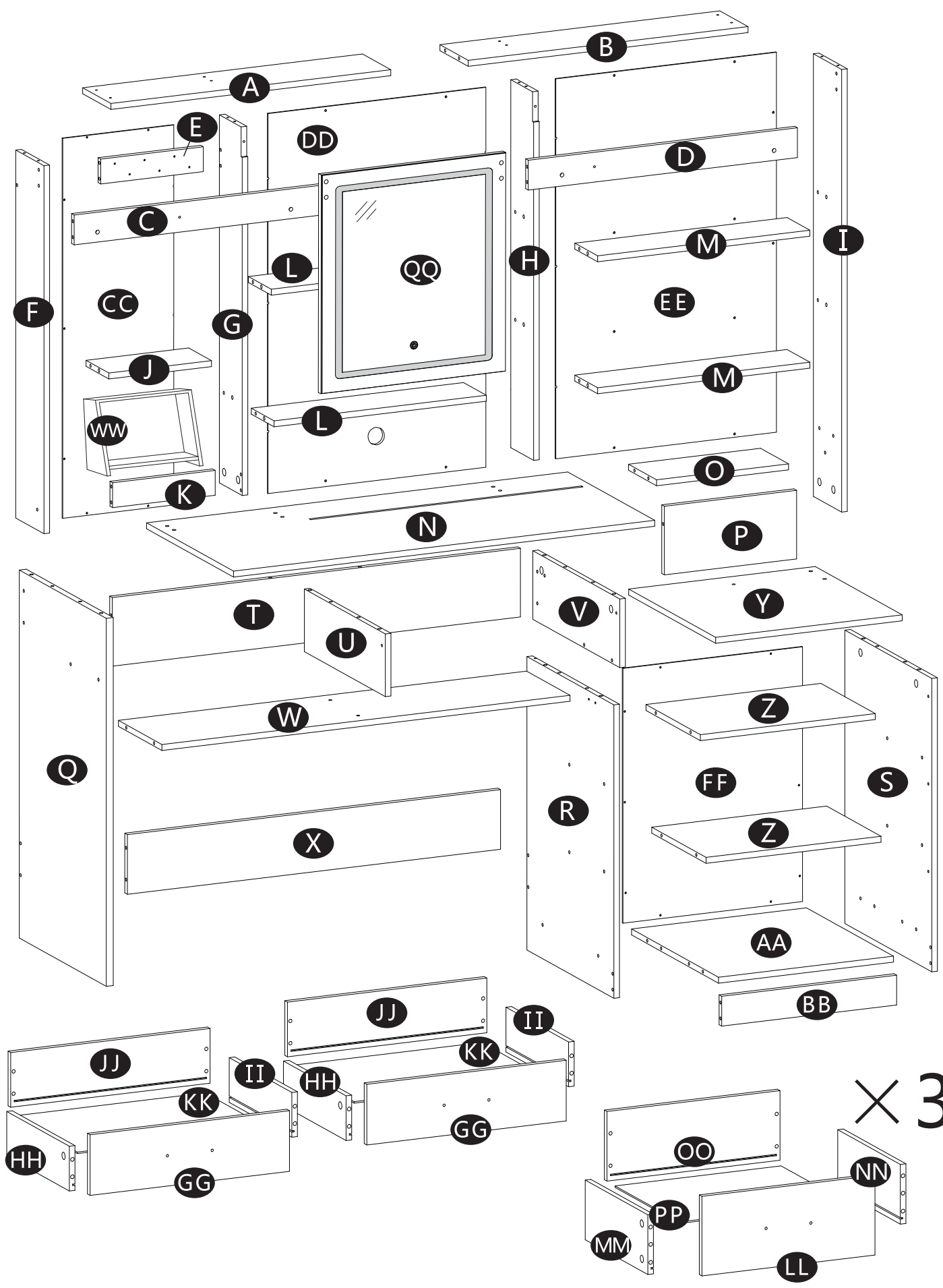

1

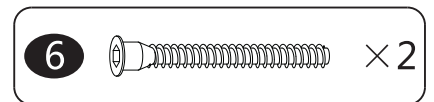
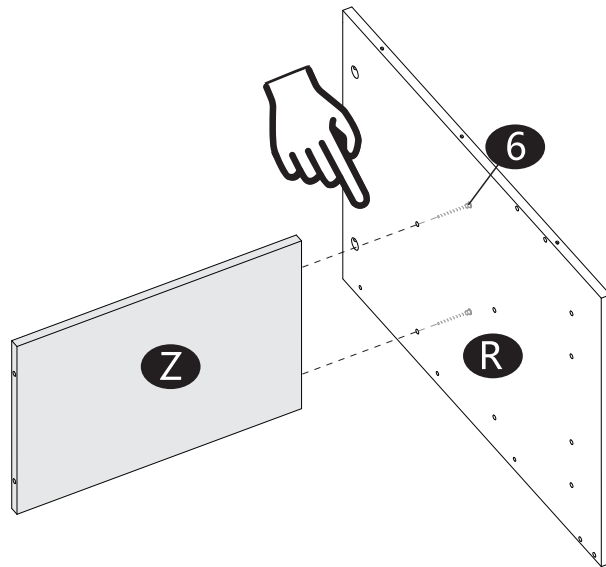

2

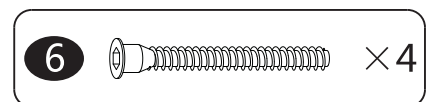
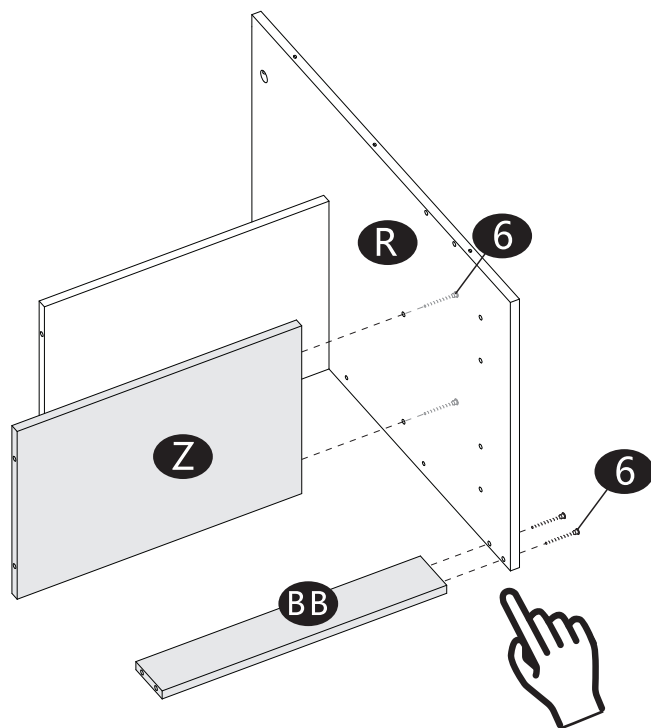

3

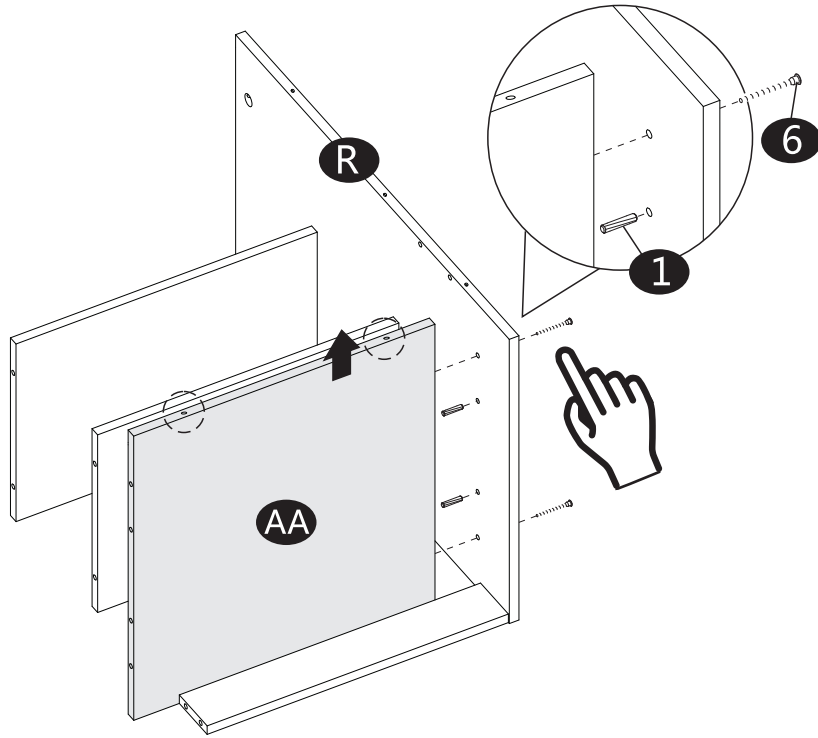

4

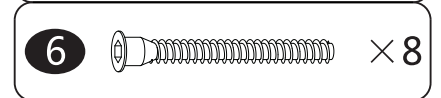
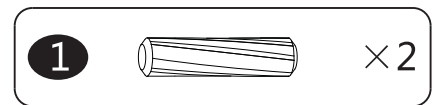
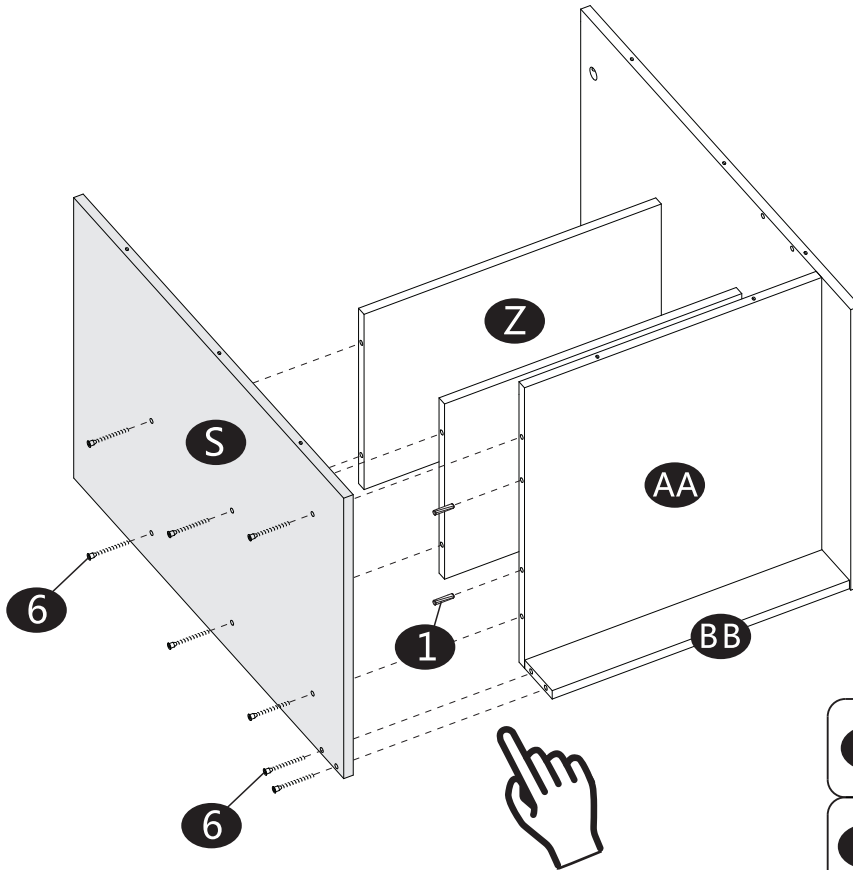

5

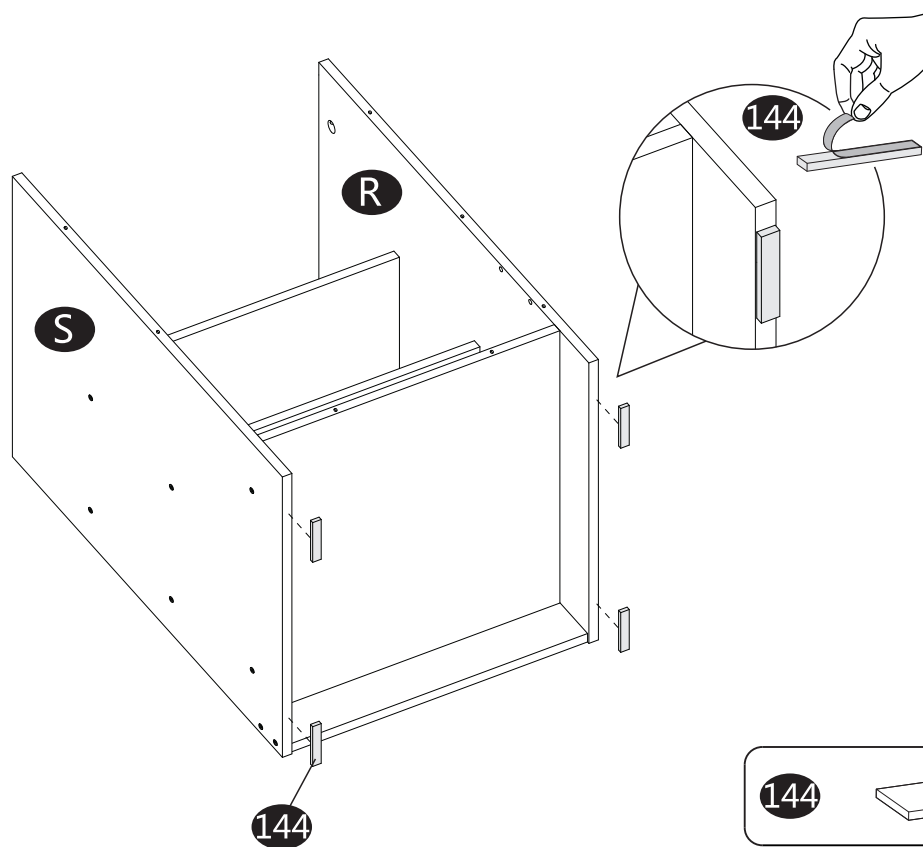

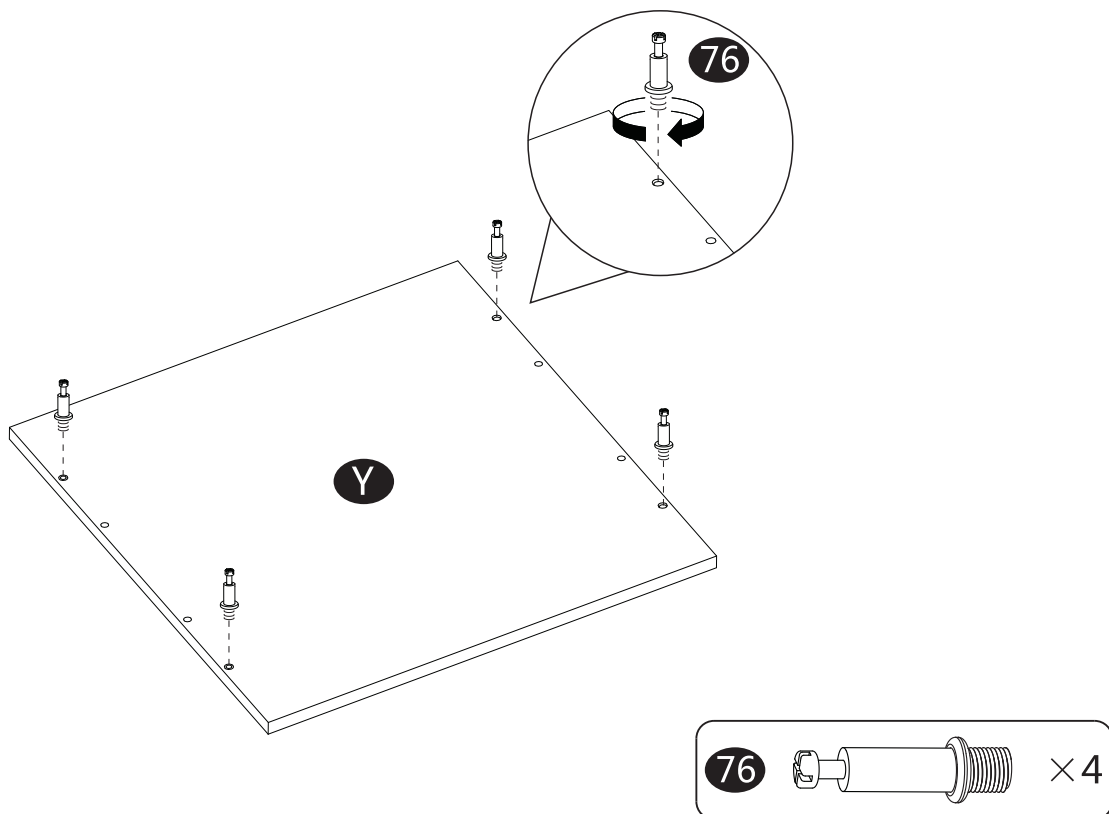

6



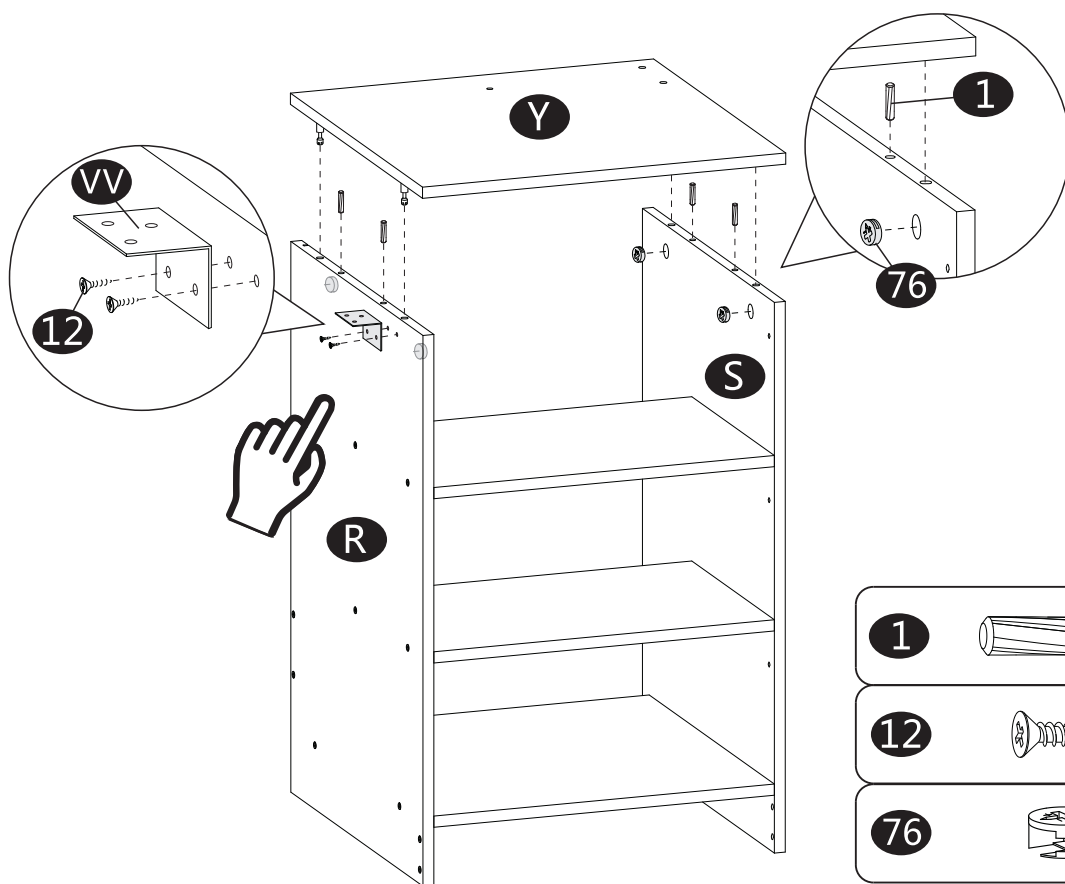

7

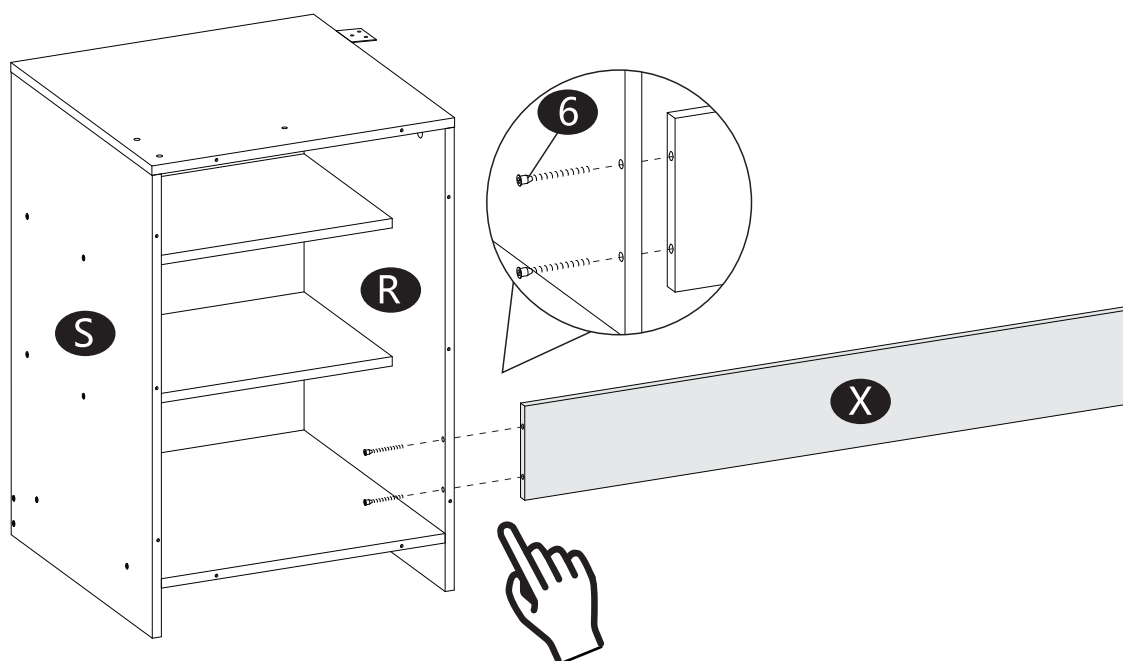

1		×4
12		×2
76		×4

8



6		×2
----------	---	----

9

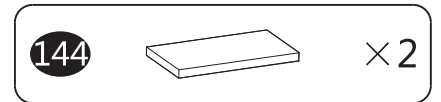
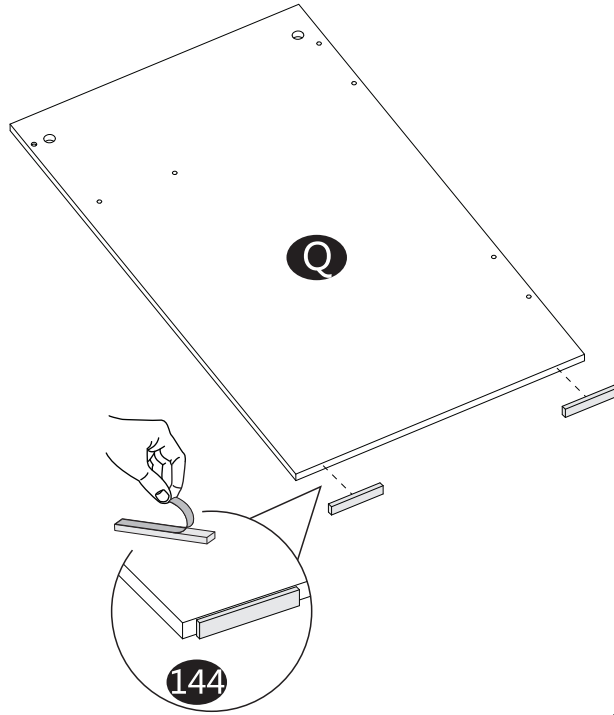

10

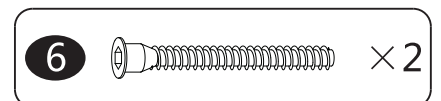
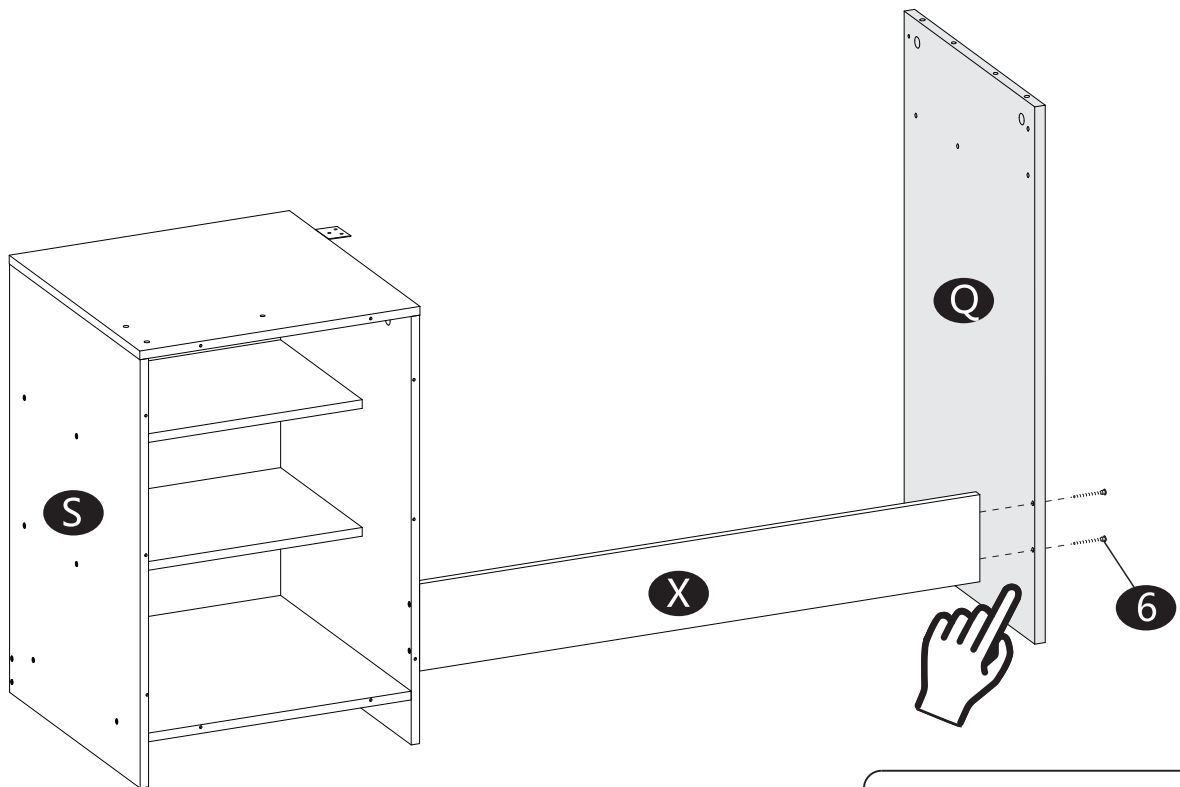

11

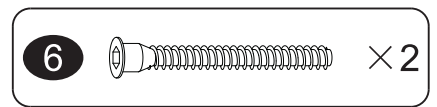
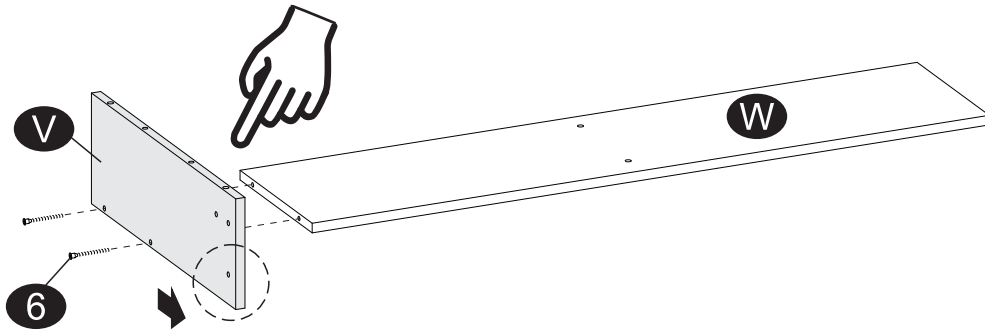

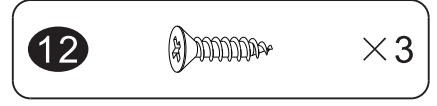
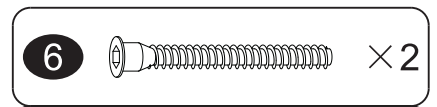
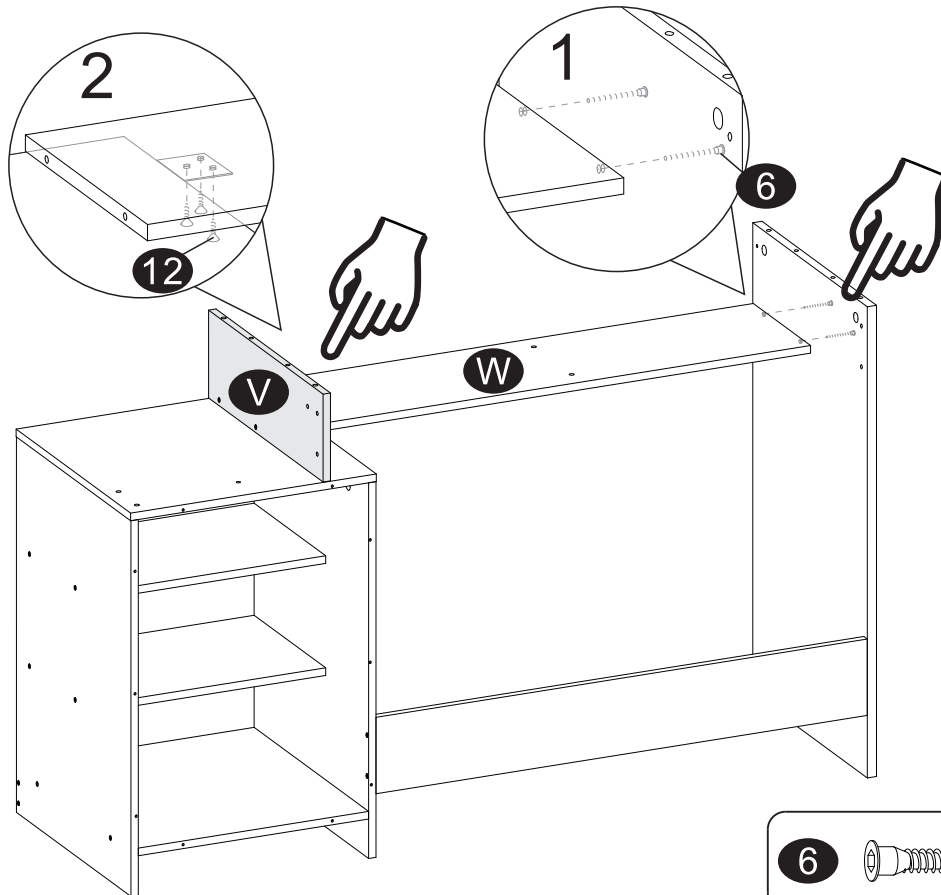

12



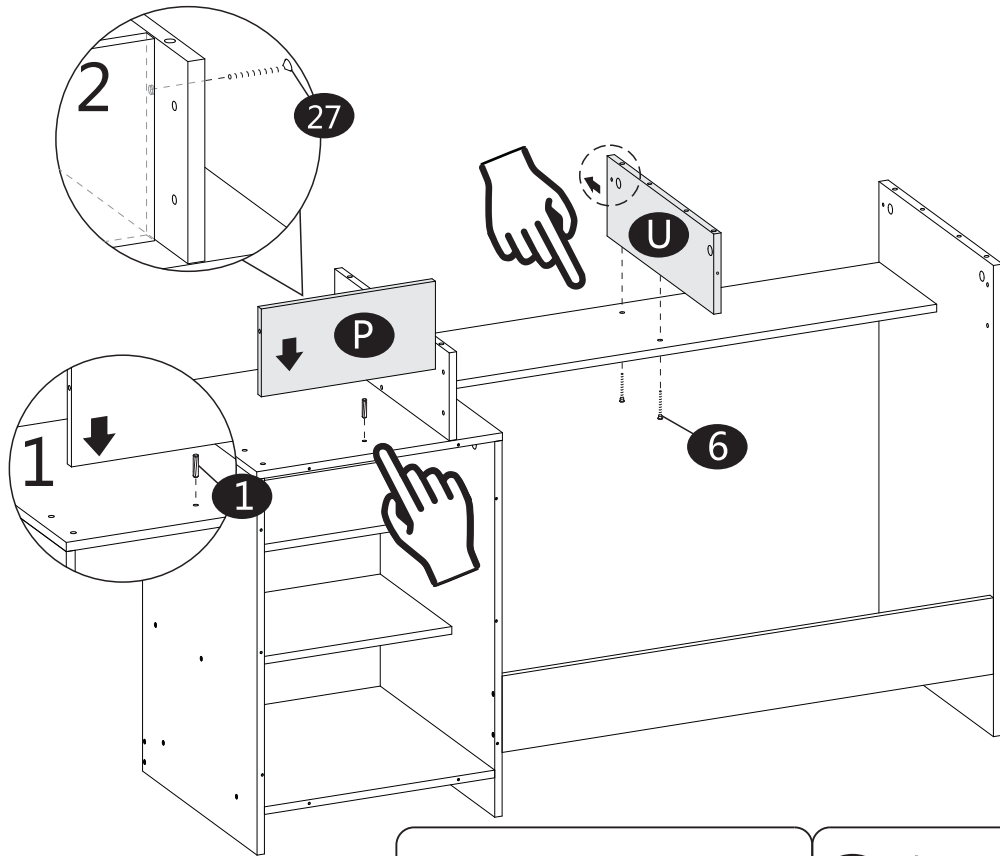

13

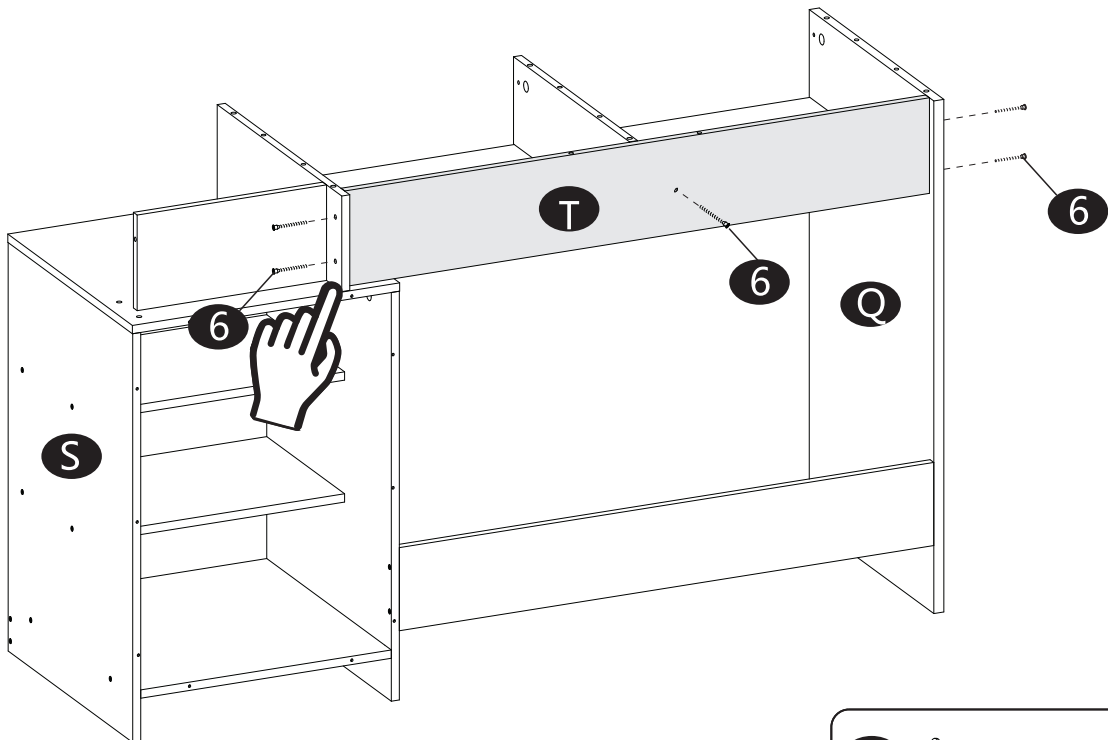

- 1  × 1
- 6  × 2
- 27  × 1

14



- 6  × 5

15

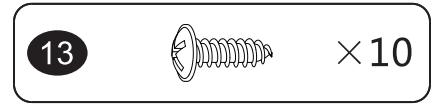
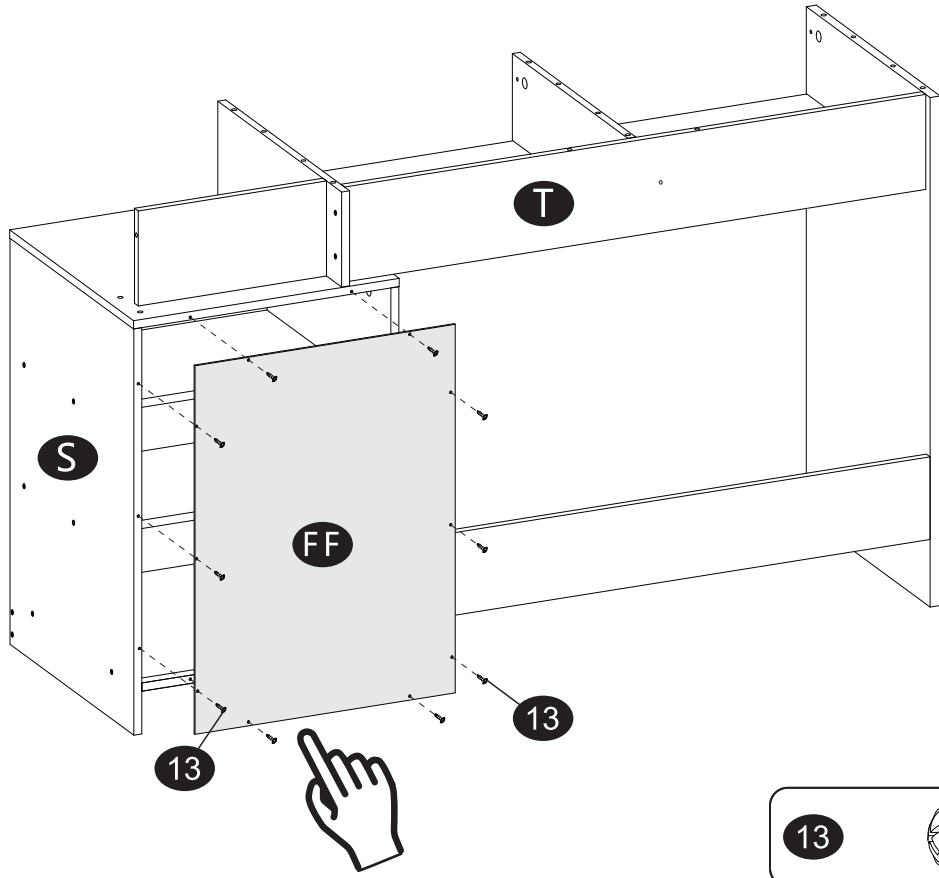

16

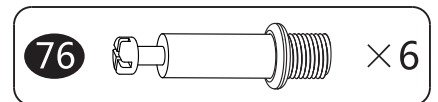
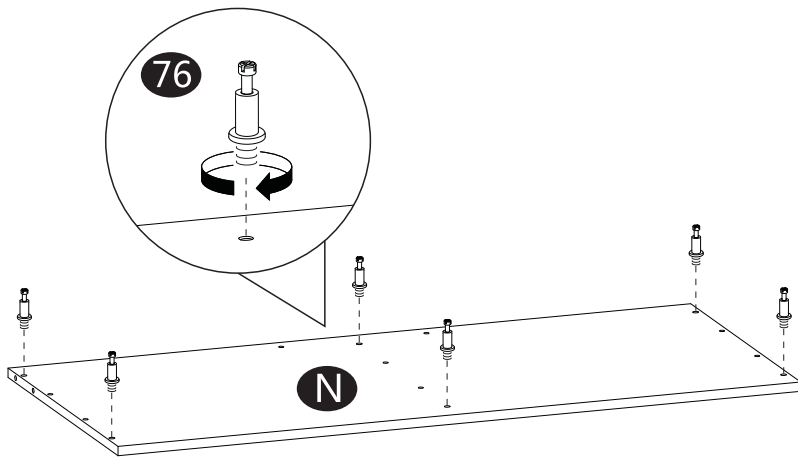

17

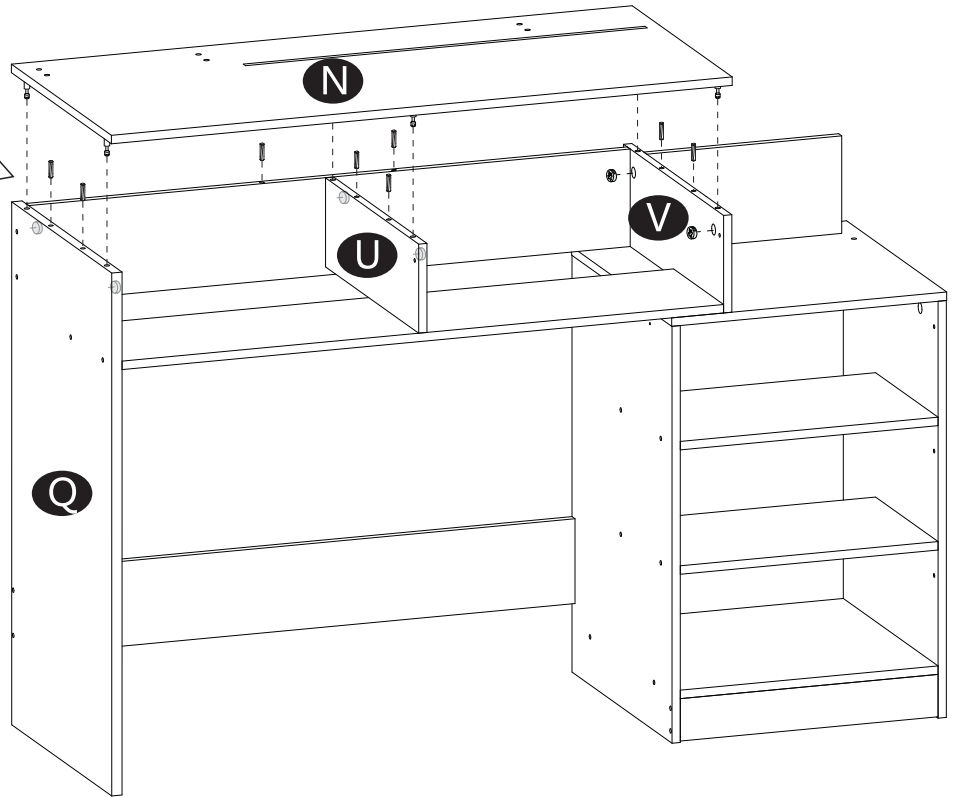
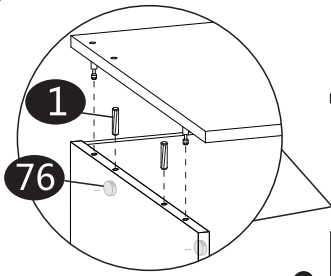

18

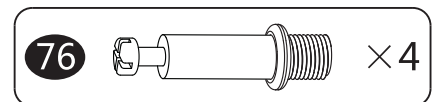
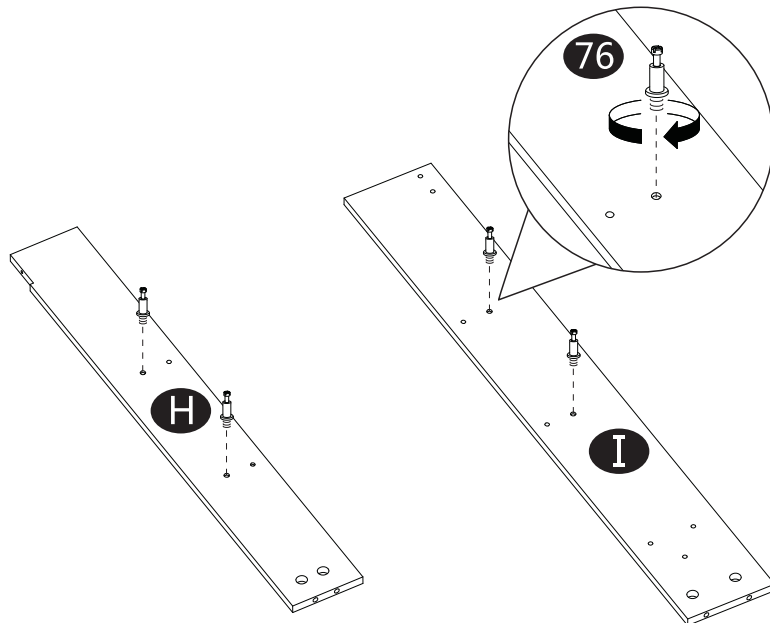

19

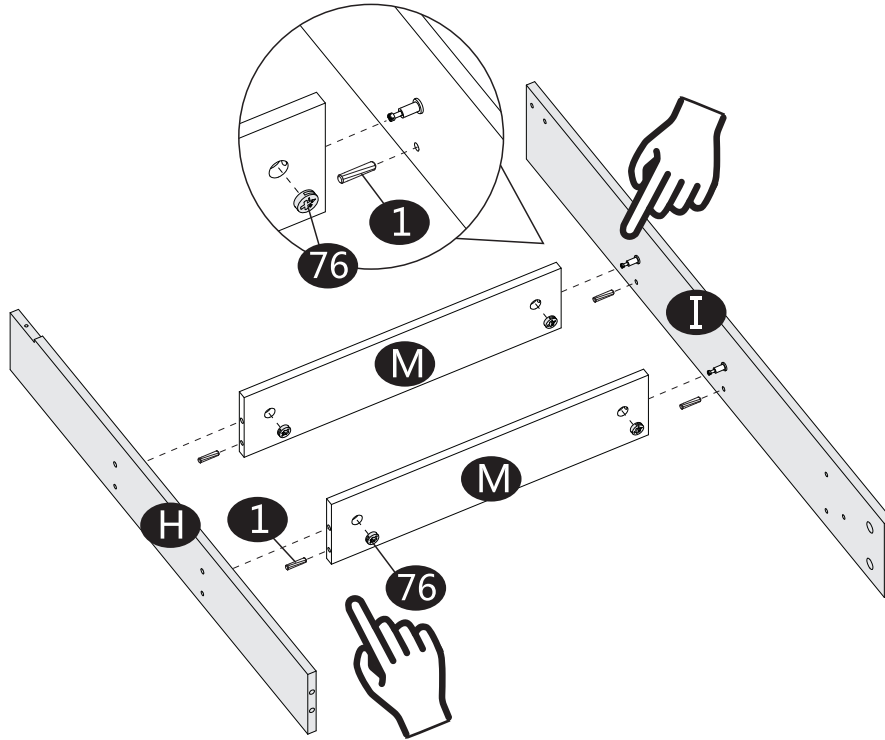

20

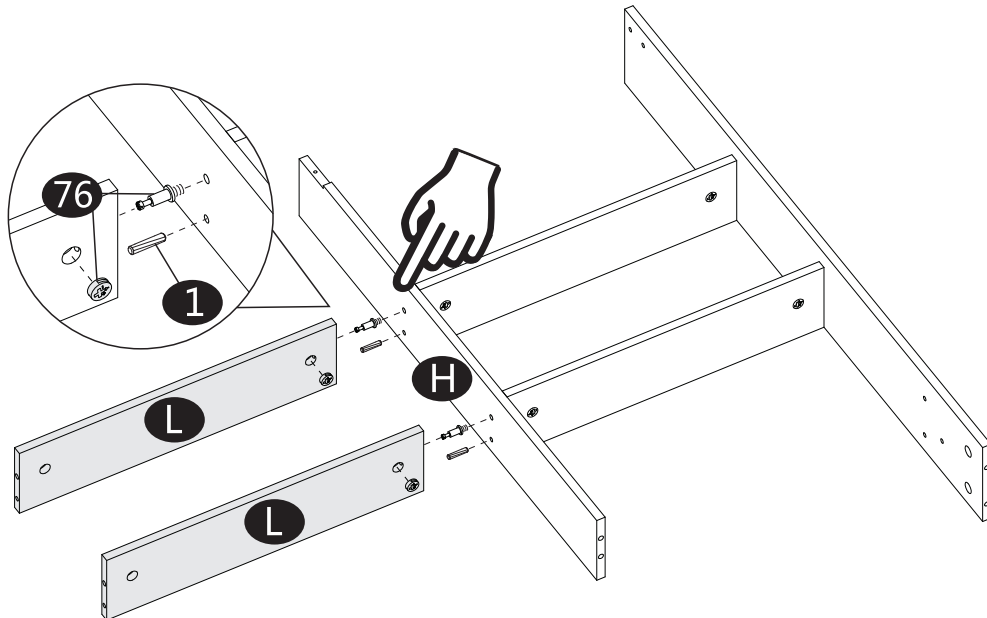

21

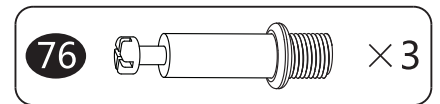
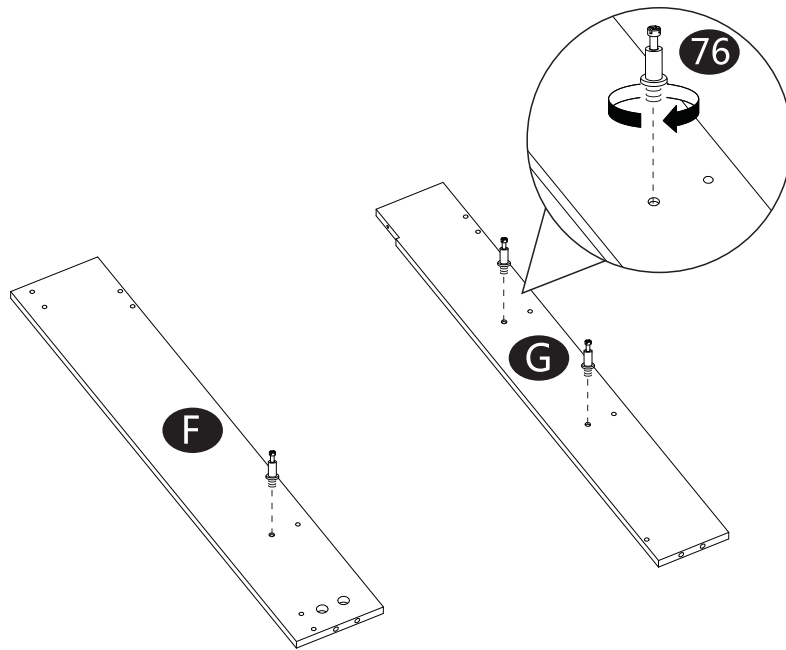

22

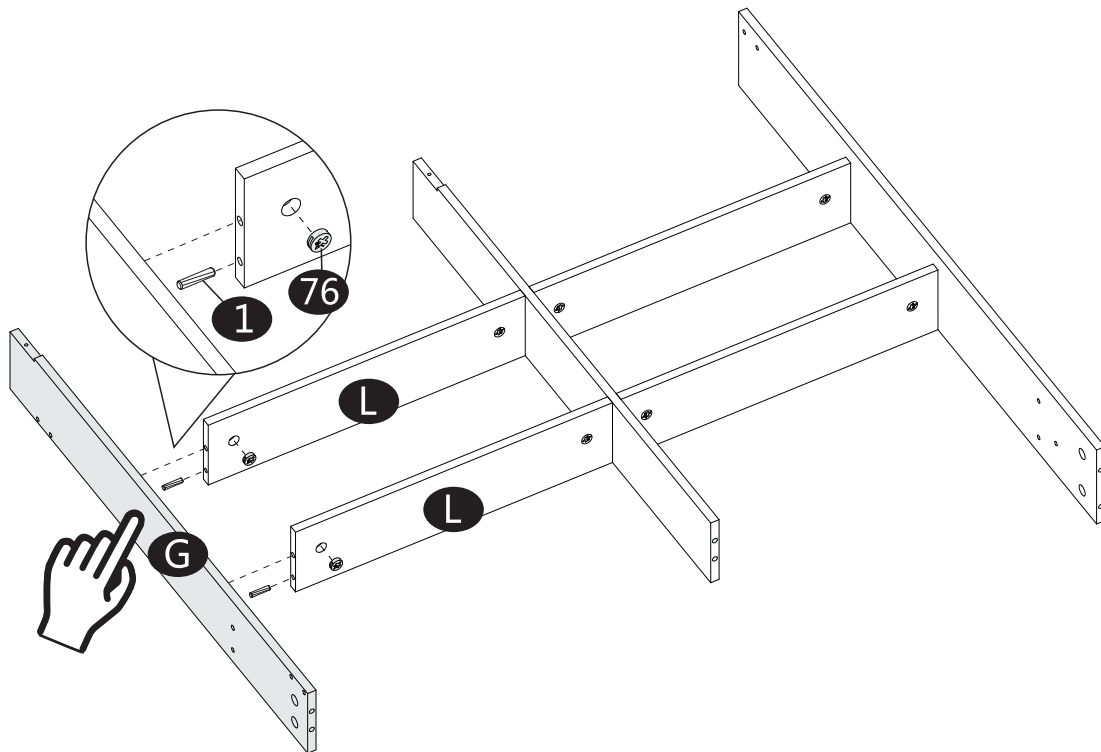

23

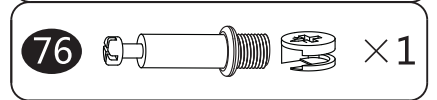
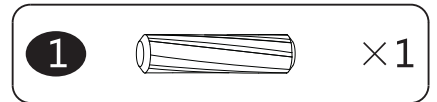
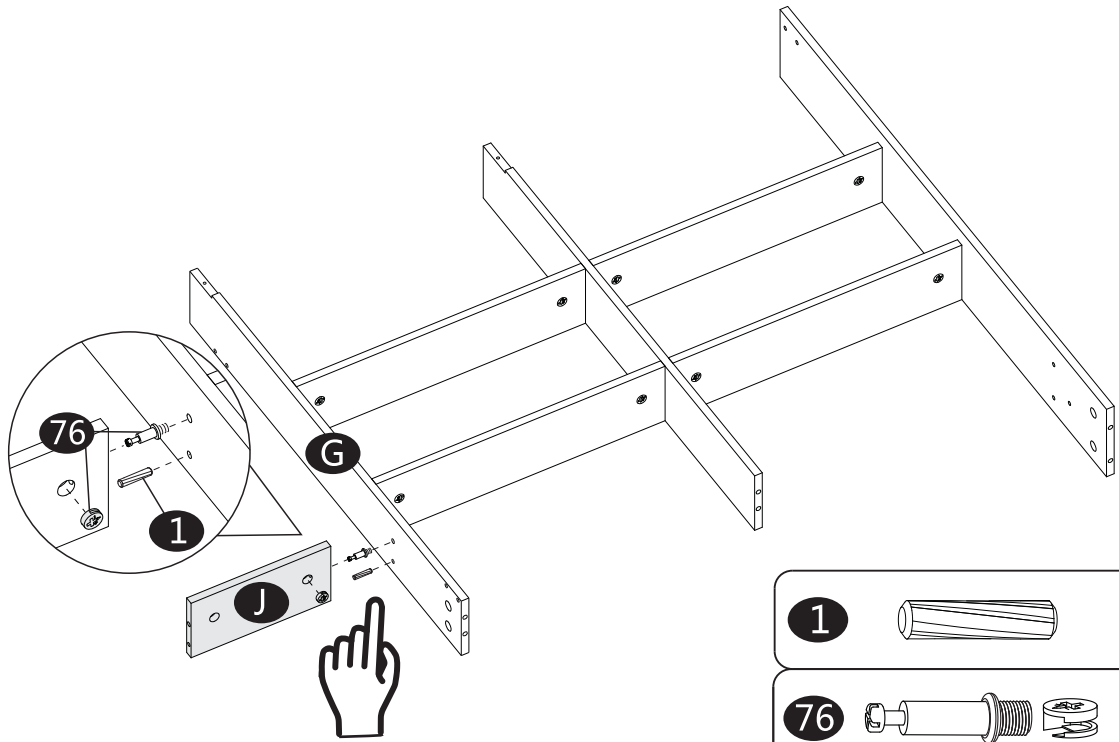

24

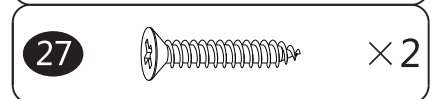
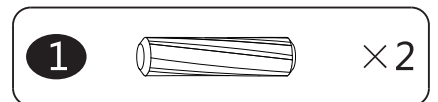
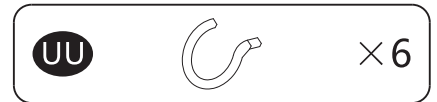
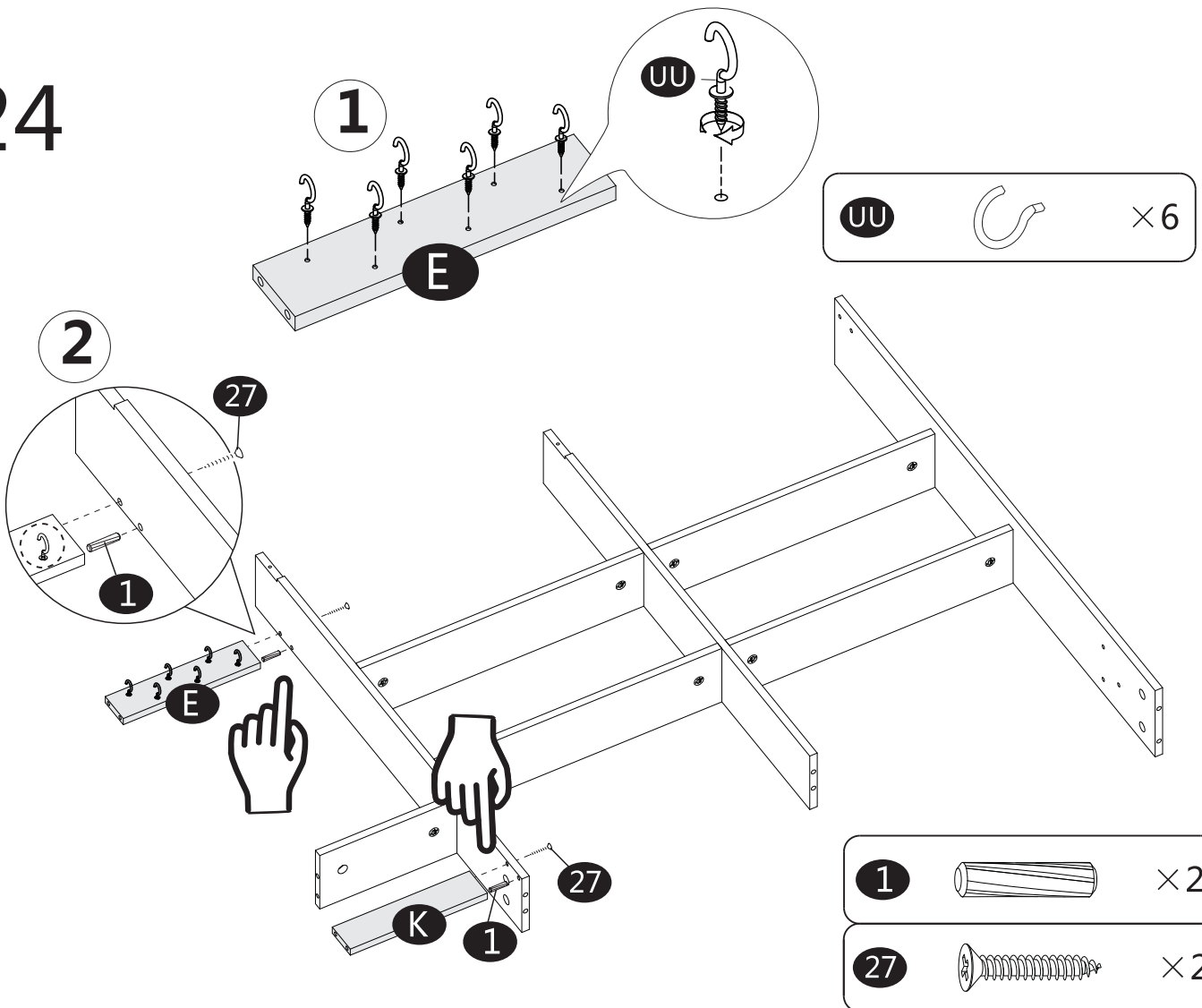

25

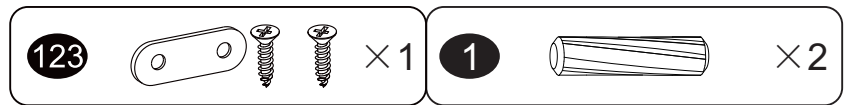
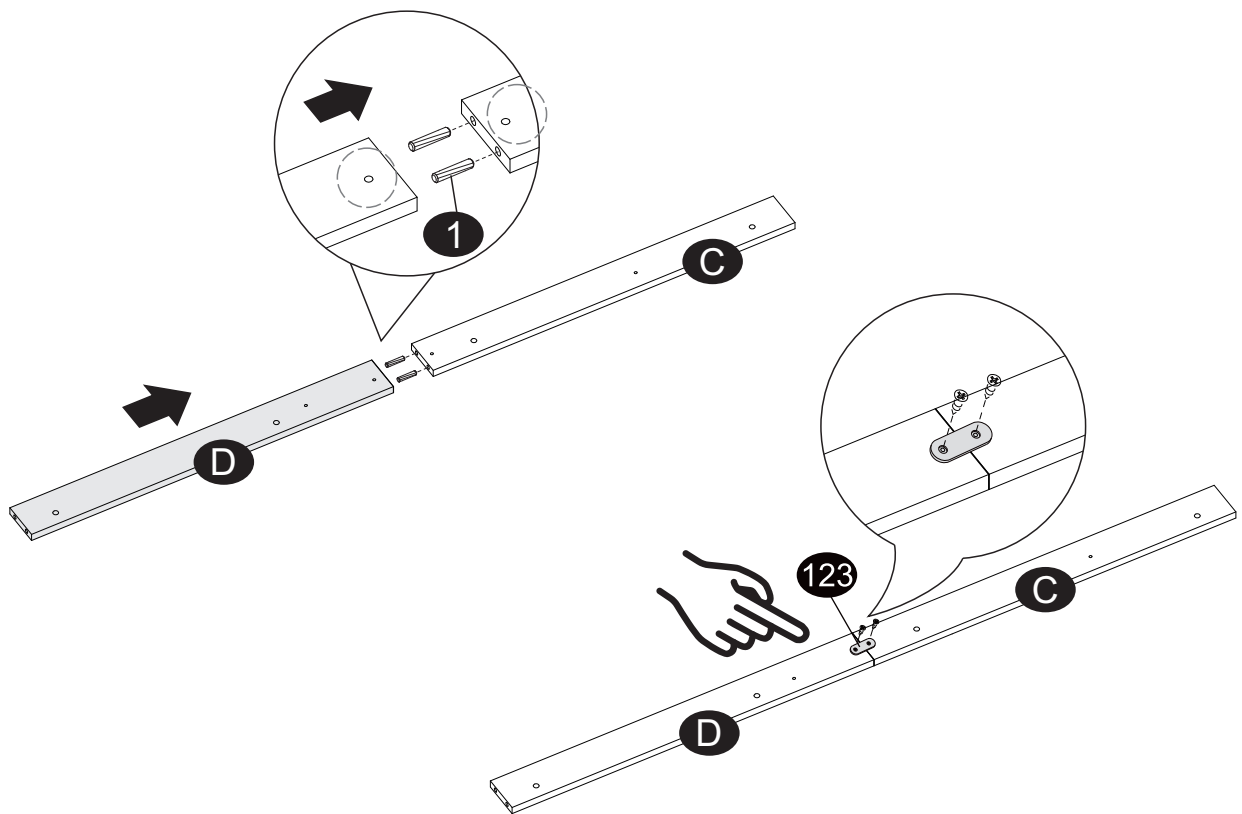

26

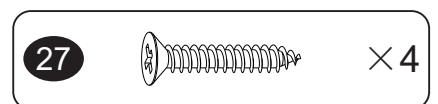
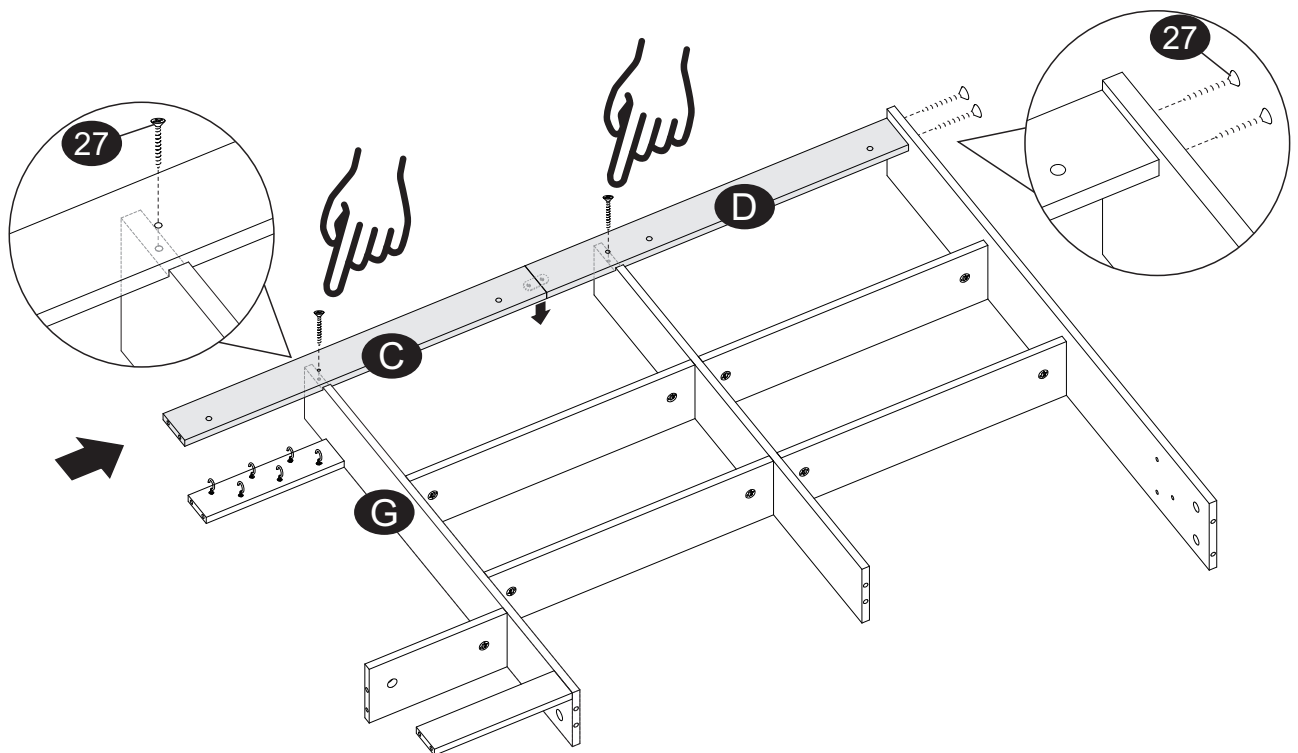

27

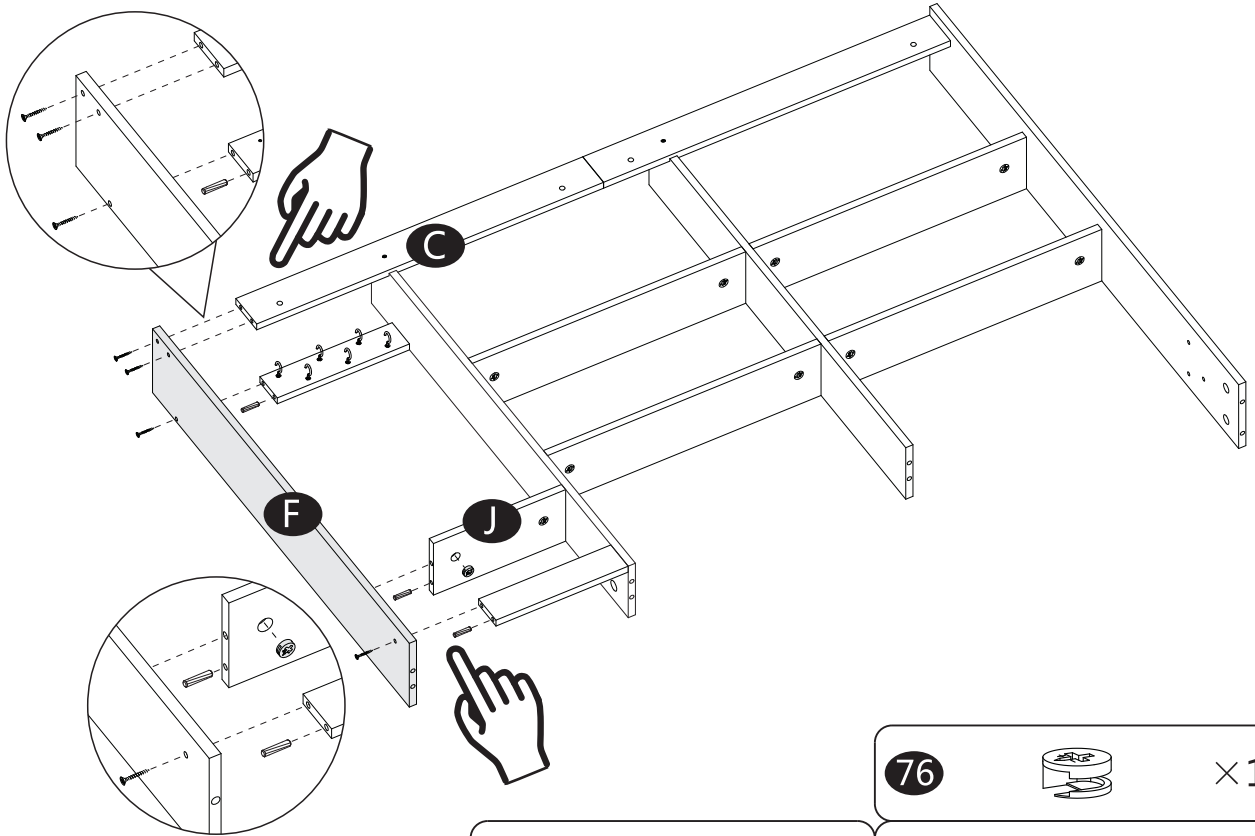

1 × 3

76 × 1

27 × 4

28

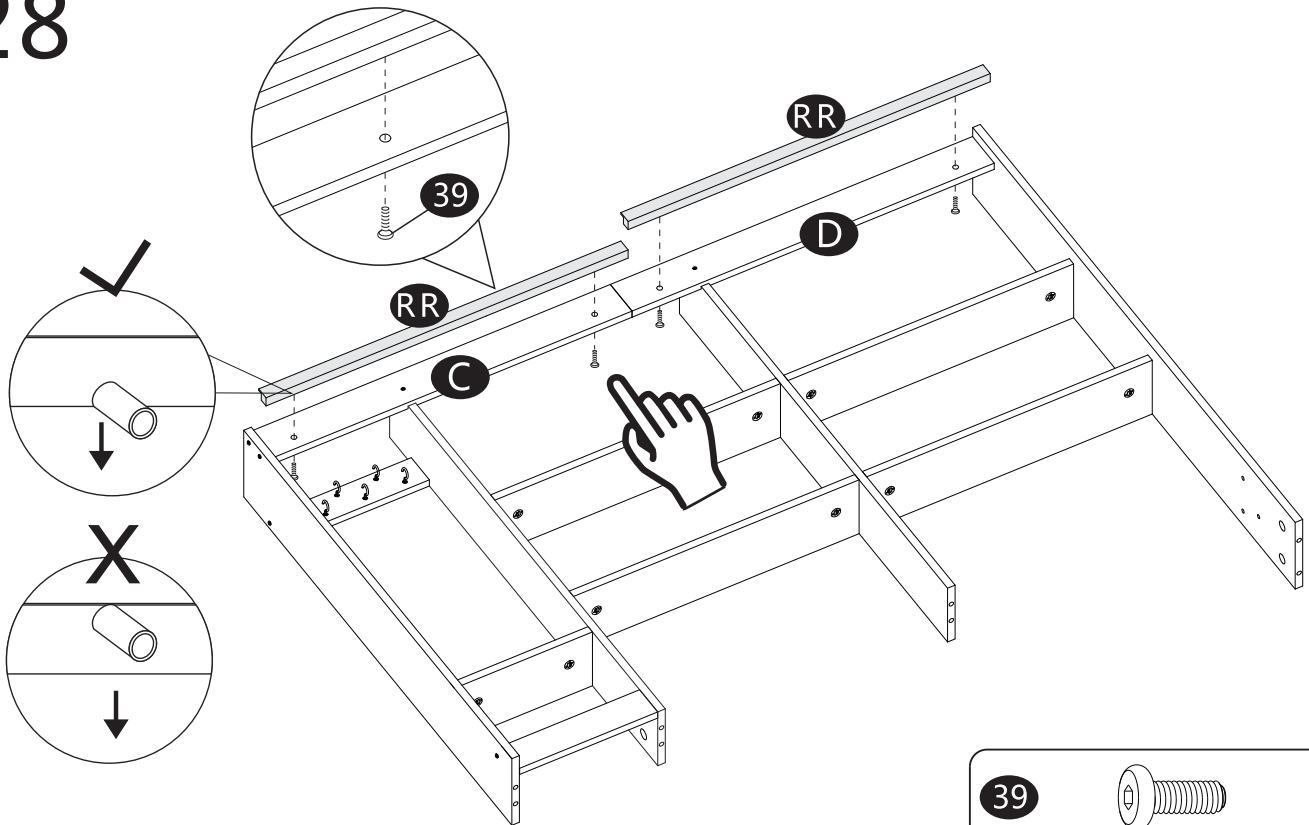

39 × 4

29

The holes on the long side of the board are located on the back

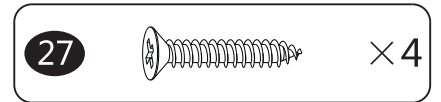
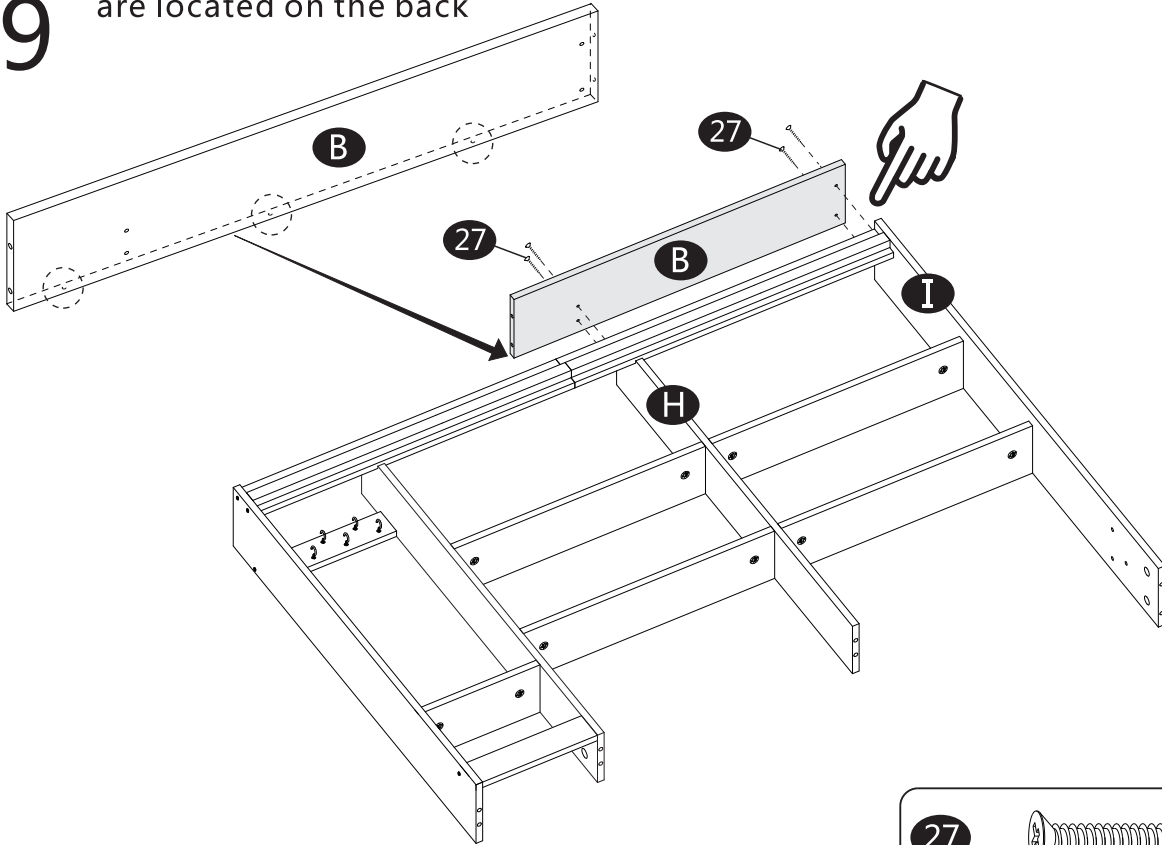

30

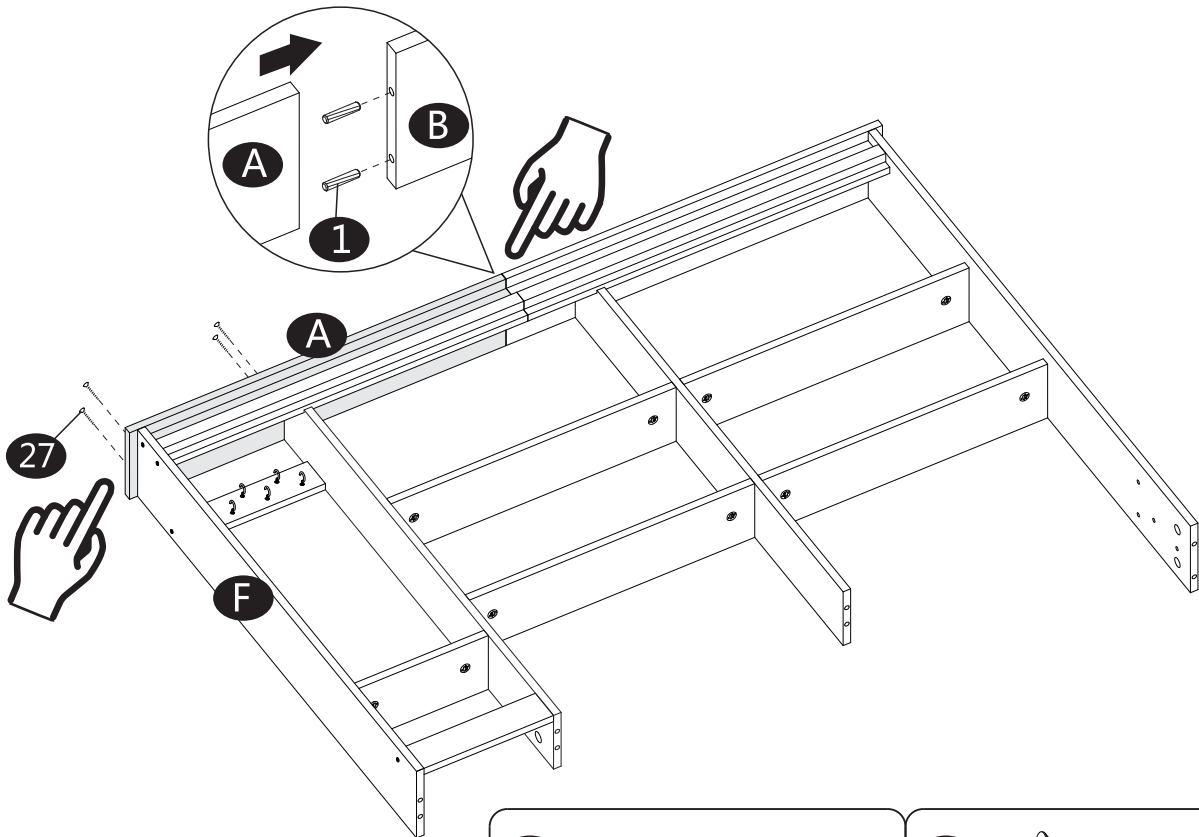

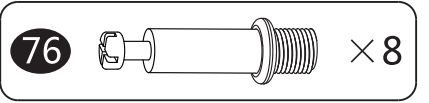
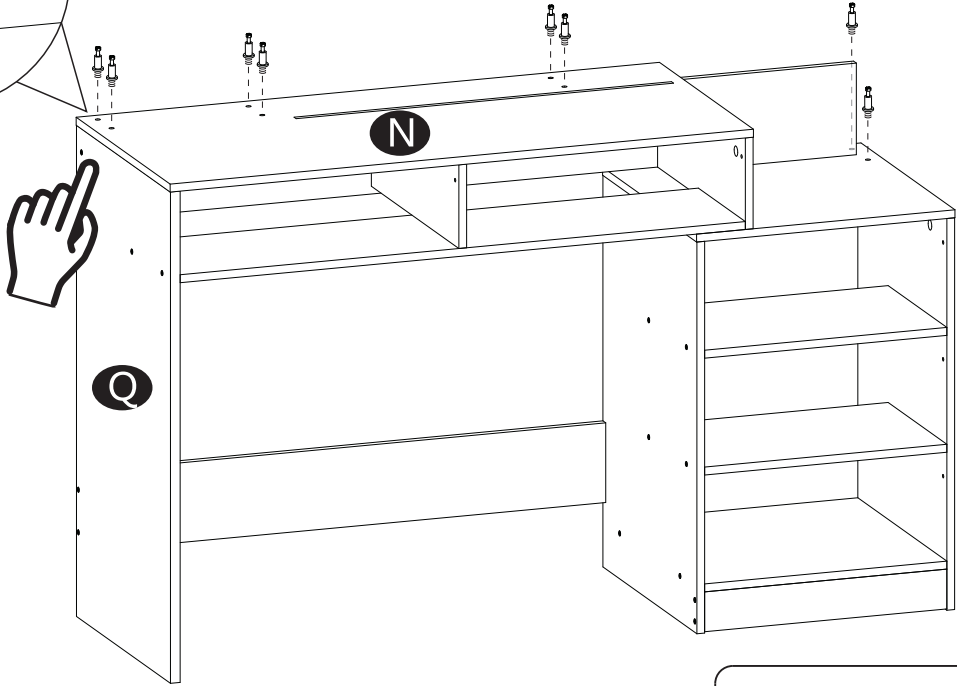
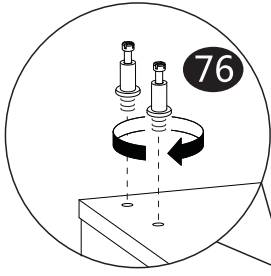

31



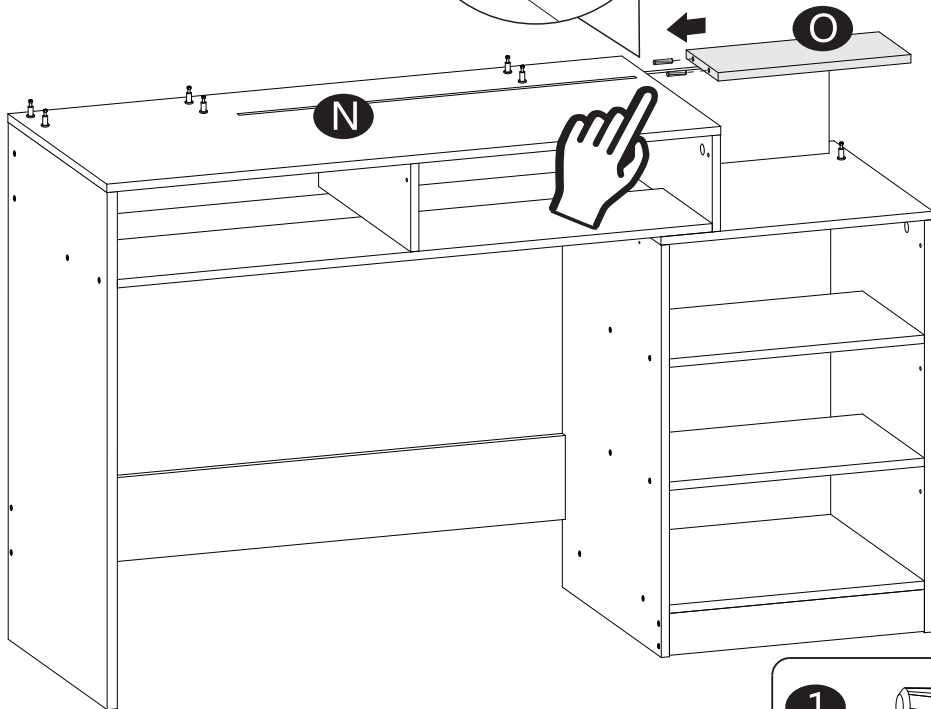
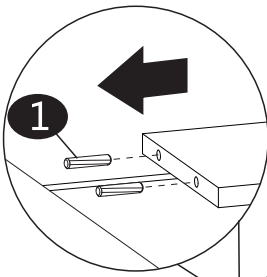

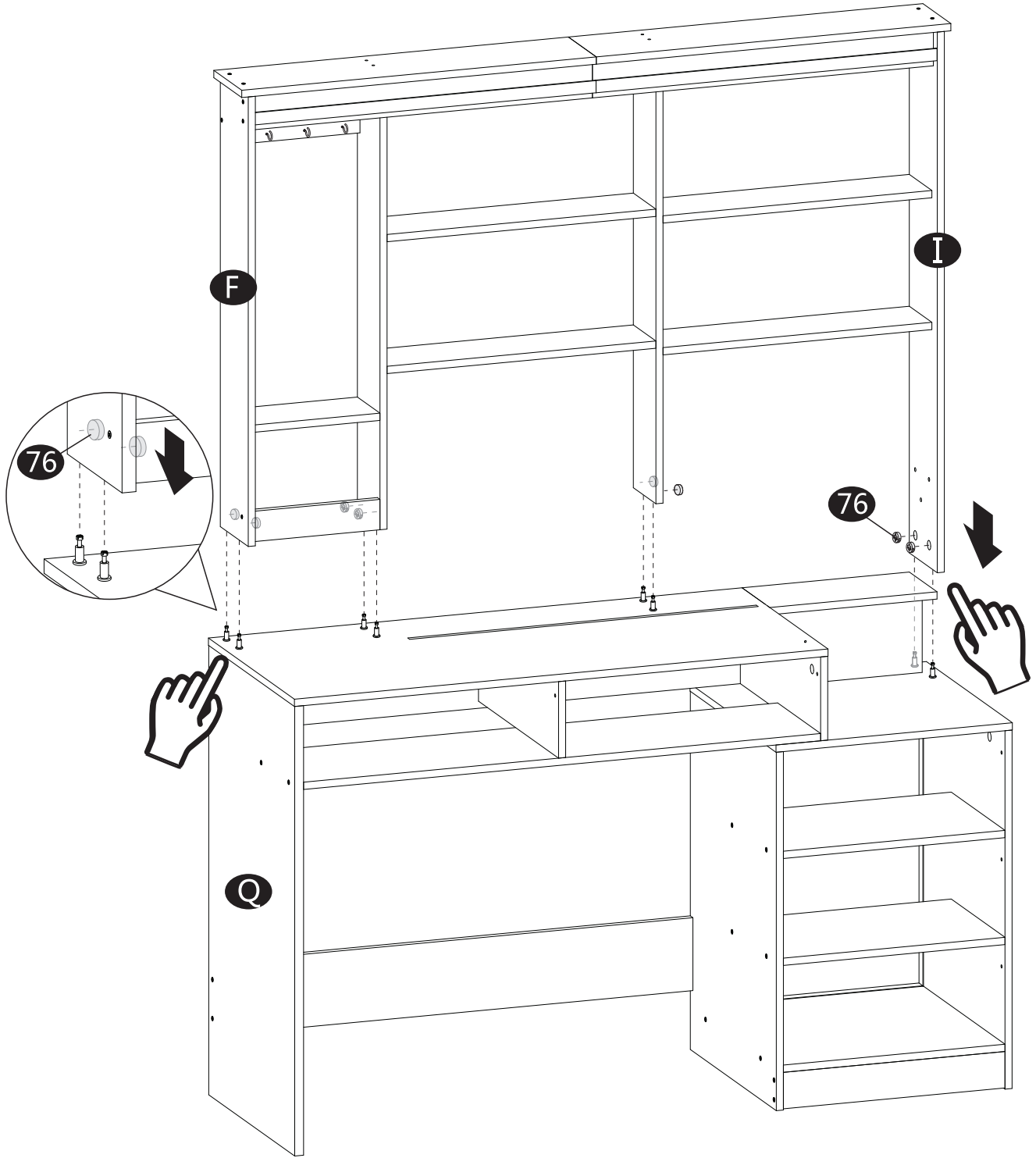

32



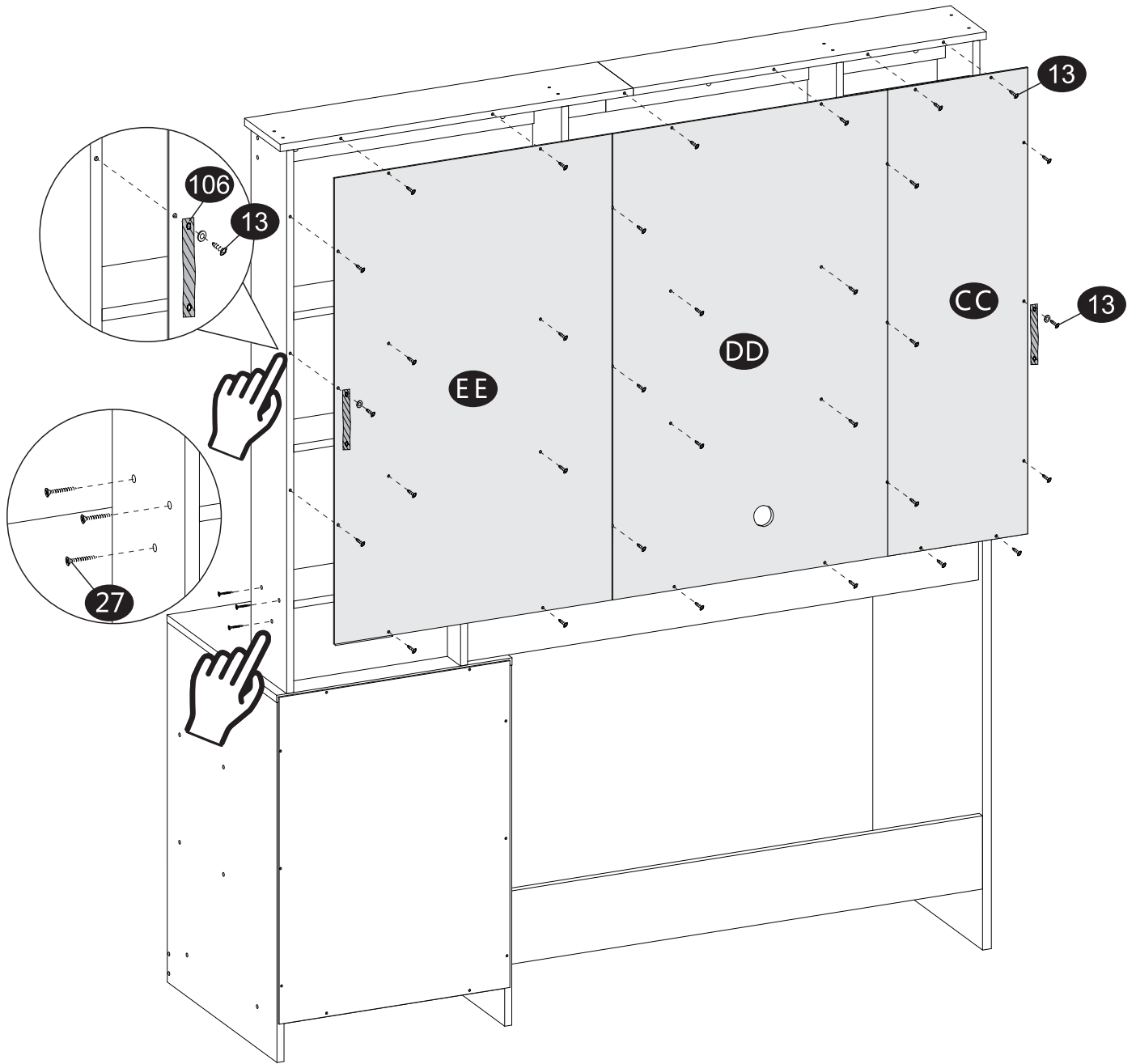

76  × 8

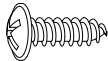

27  × 3	13  × 32
	106  × 2

35

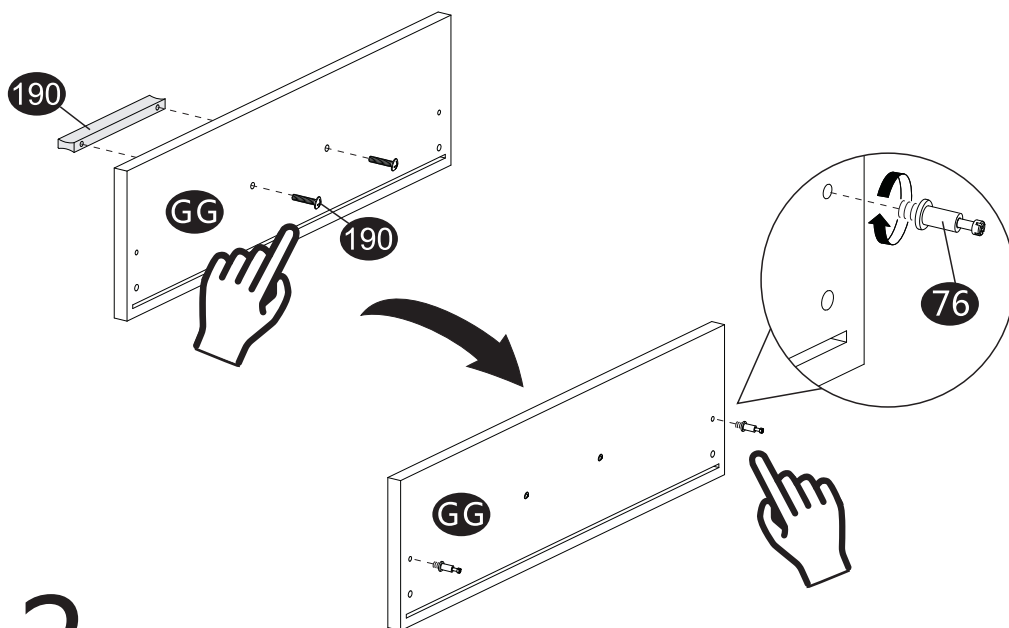

× 2



36

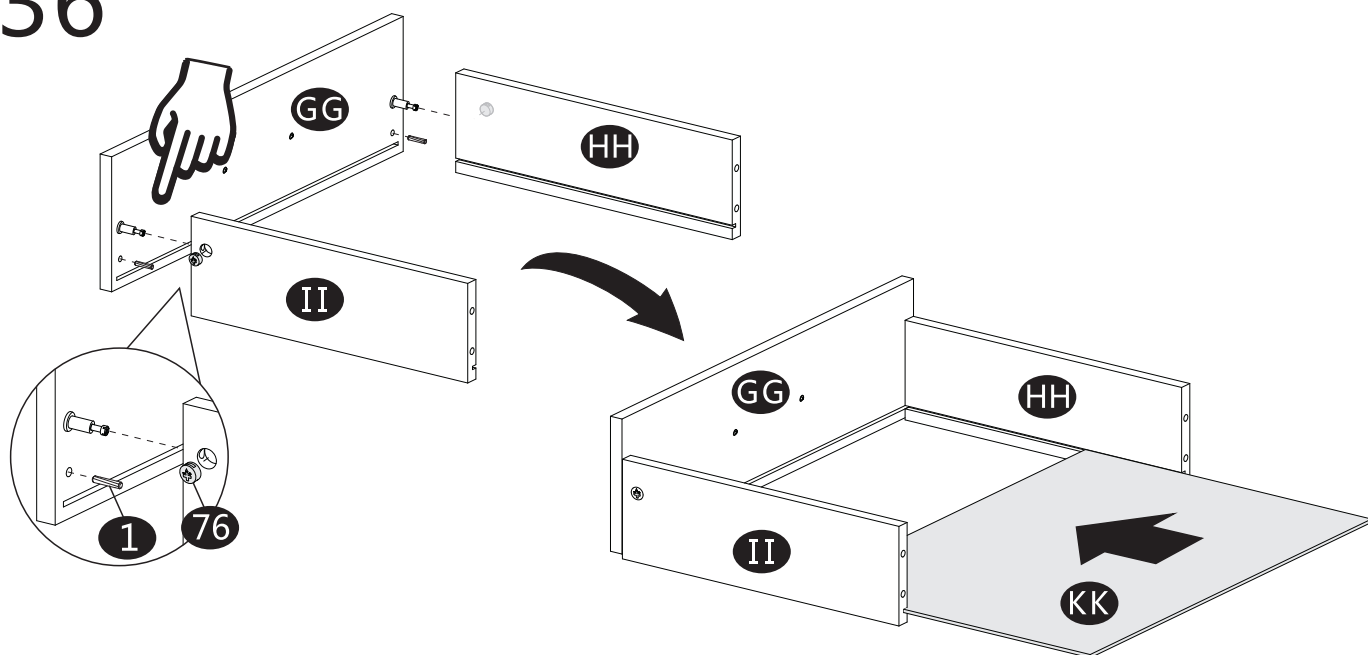

× 2



37

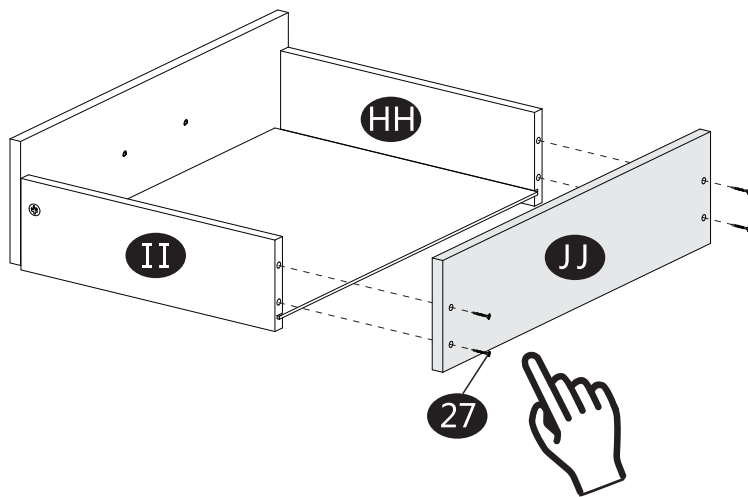

× 2

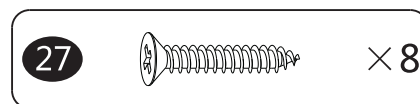

38

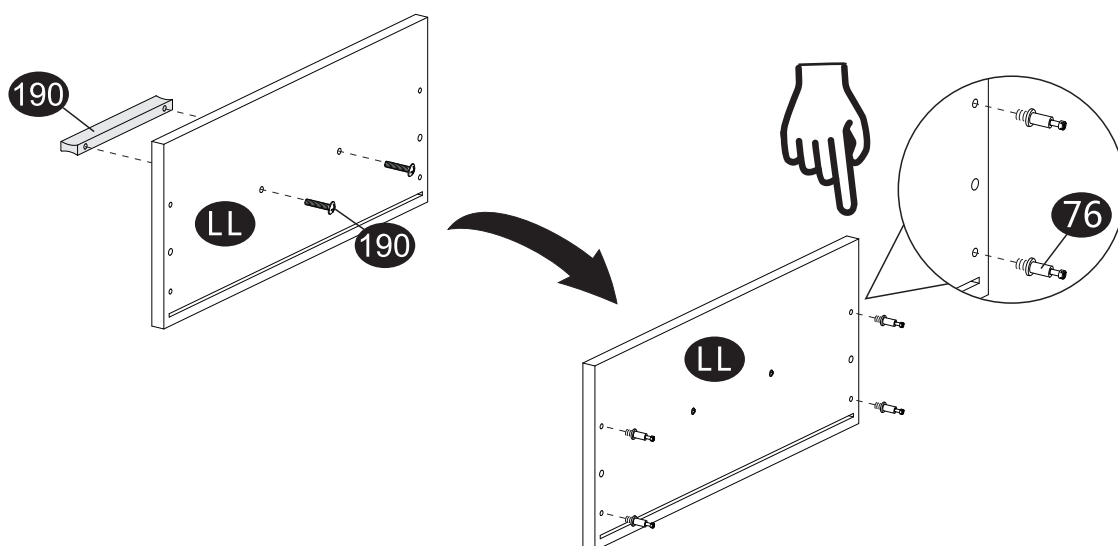

× 3



39

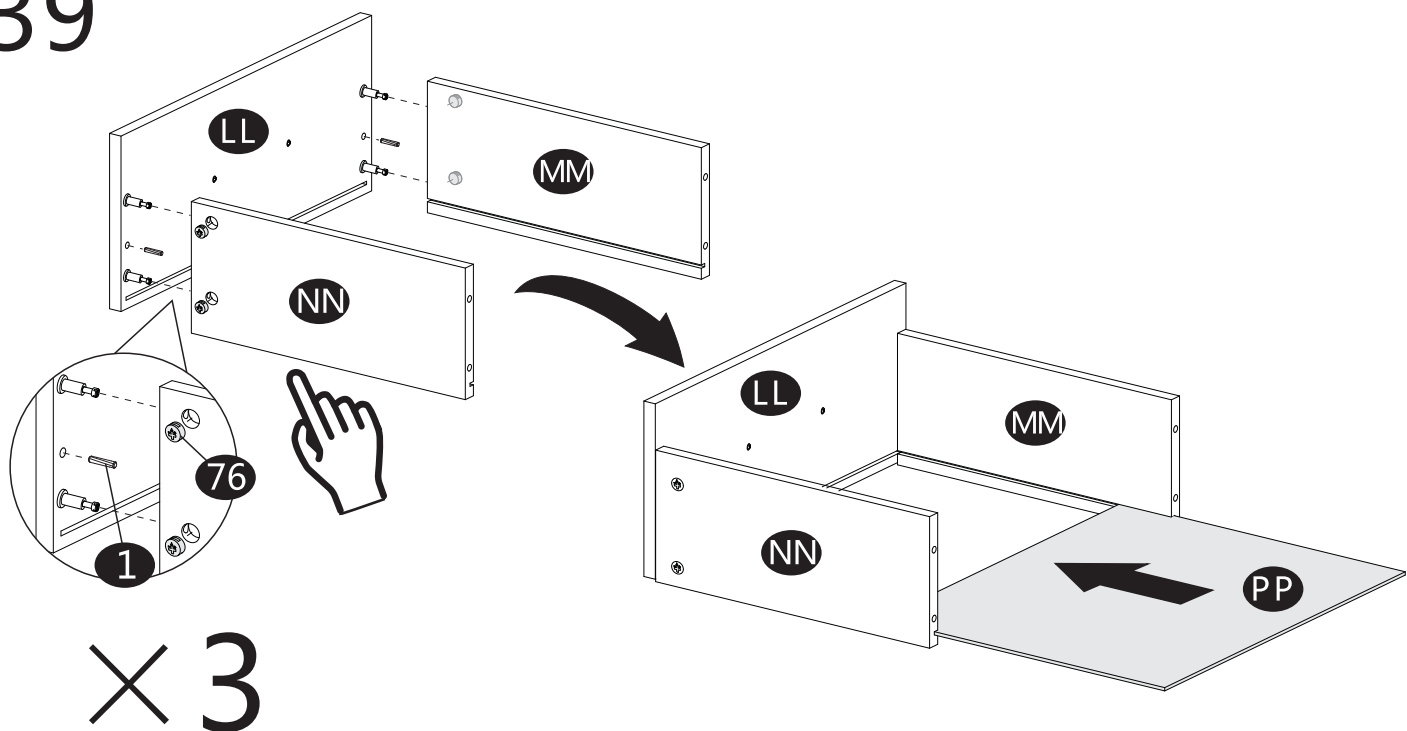

40

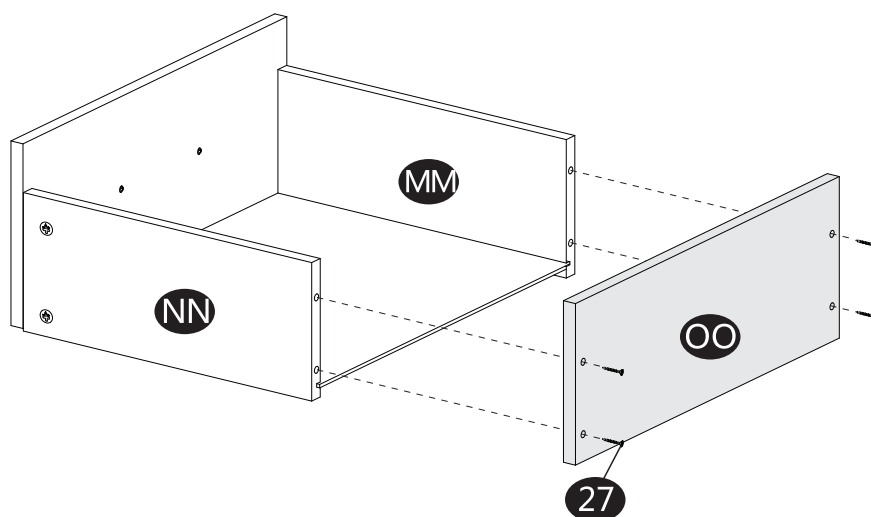

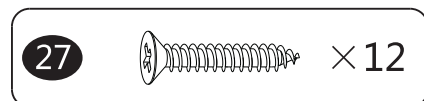

× 3

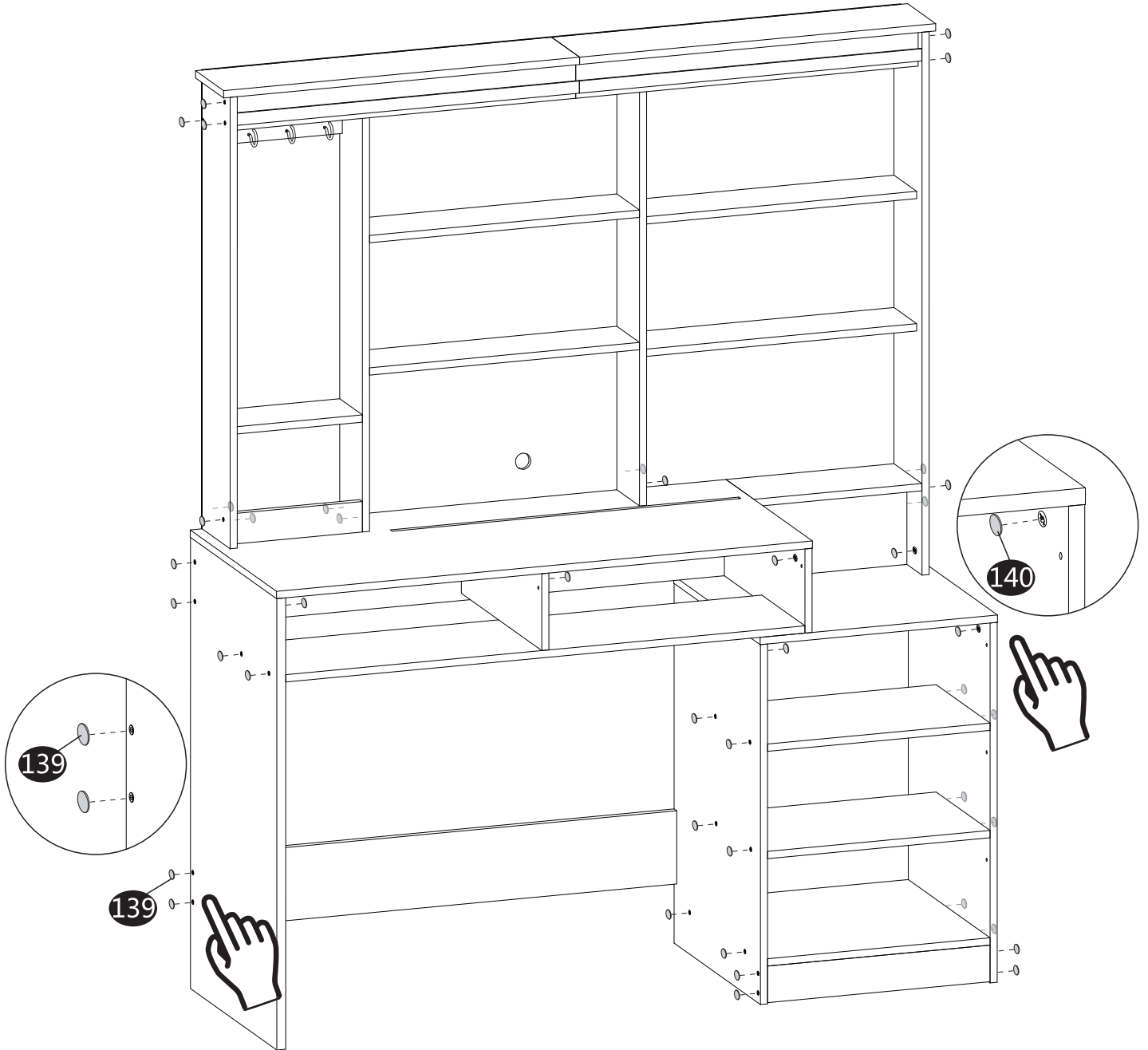
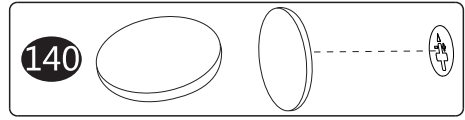
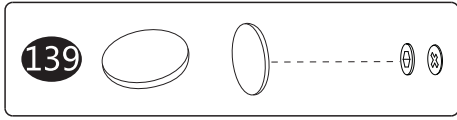

41



139  × 31

140  × 12



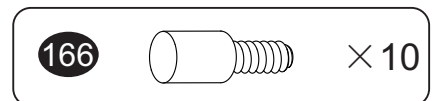

44

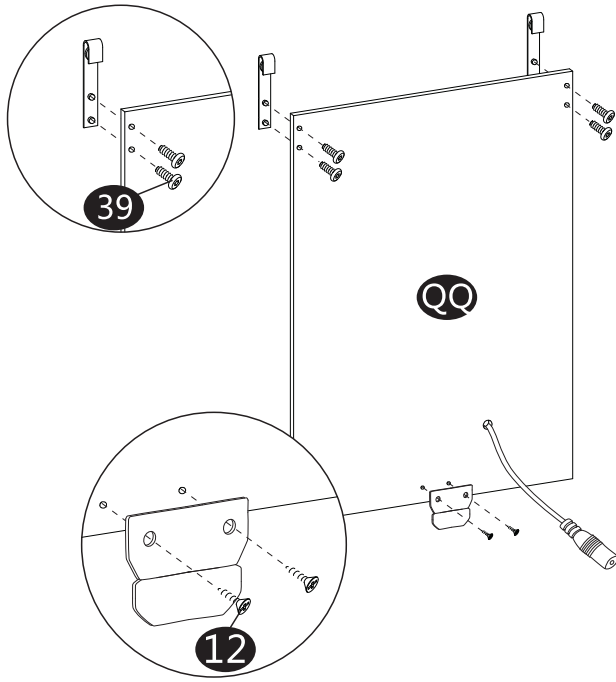

- | | | |
|----|--|----|
| TT | | ×1 |
| 12 | | ×2 |
| 39 | | ×4 |



45

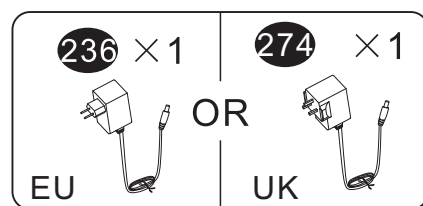
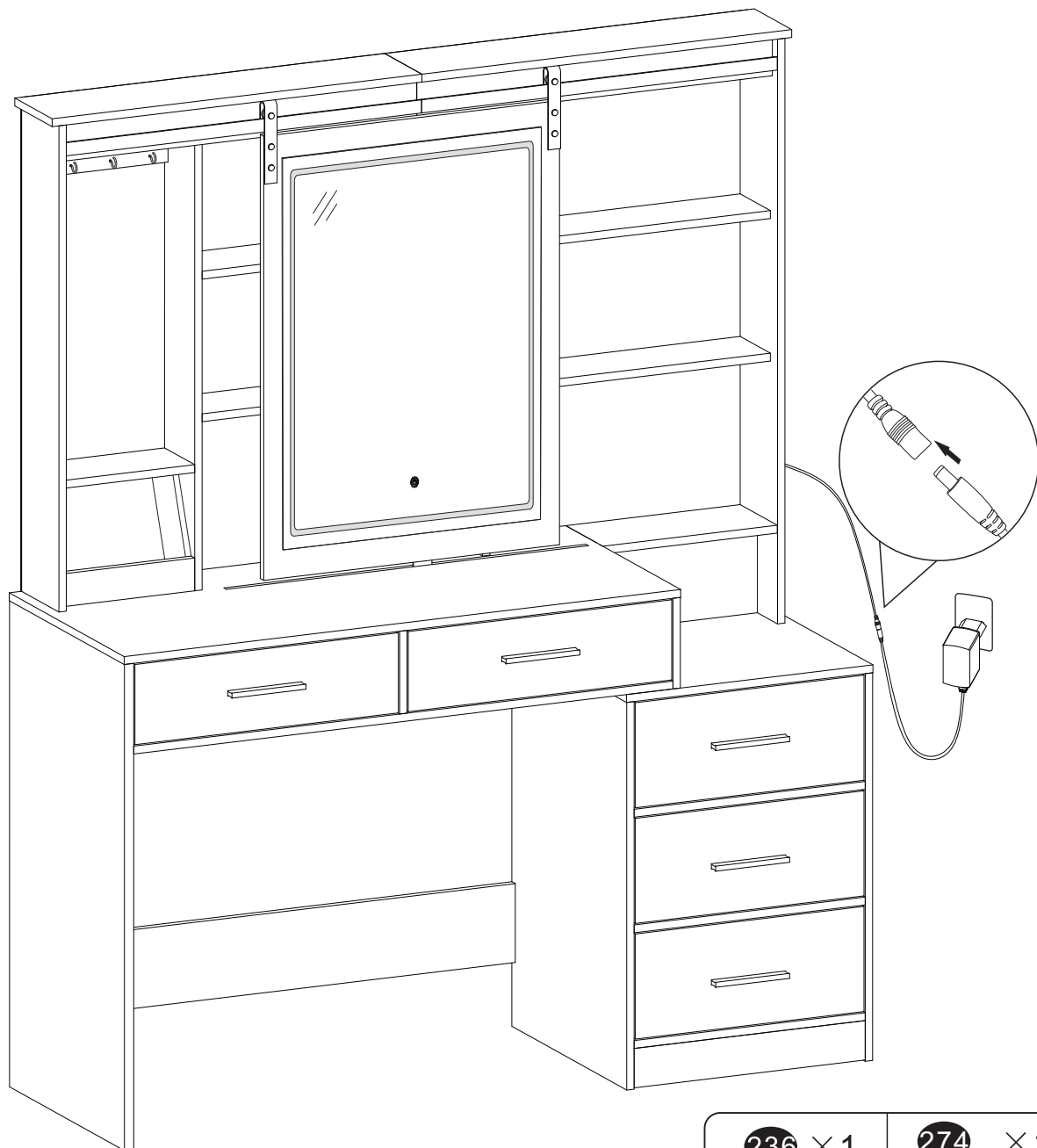

- EN. Adjustable: short press to change light color, long press to change light brightness.
- DE. Einstellbar: kurzes Drücken zum Ändern der Lichtfarbe, langes Drücken zum Ändern der Lichthelligkeit.
- FR. Réglable : une pression courte permet de changer la couleur de la lumière, une pression longue permet de changer la luminosité de la lumière.
- IT. Regolabile: premere brevemente per cambiare il colore della luce, premere a lungo per cambiare la luminosità della luce.
- ES. Ajustable: pulsación corta para cambiar el color de la luz, pulsación larga para cambiar el brillo de la luz.

46

