

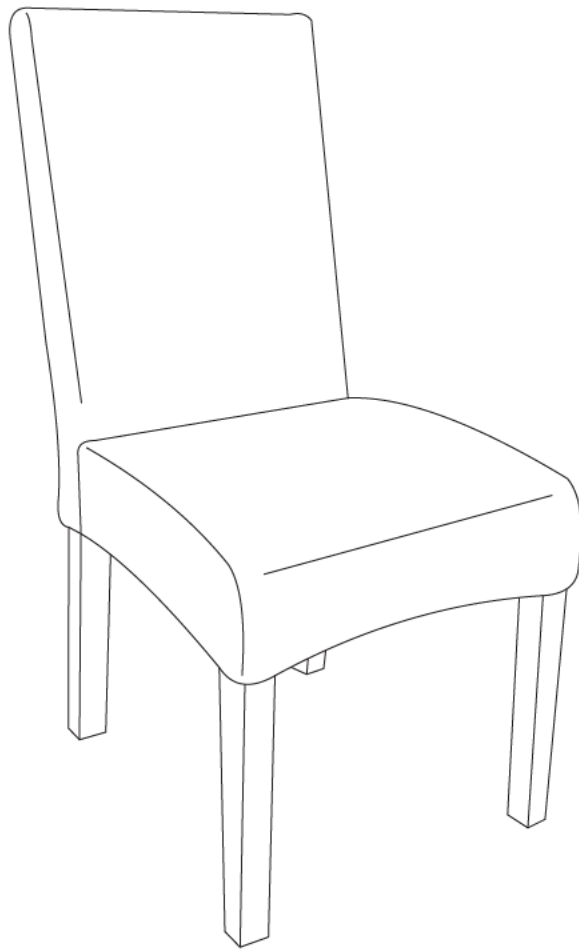

Dining Chair

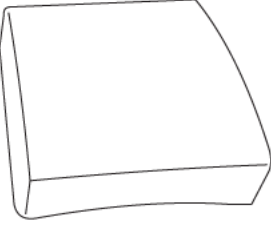
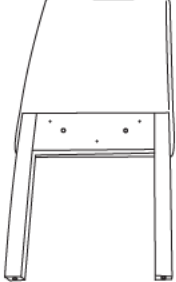
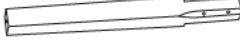

PART LIST

<p>A</p> 	<p>B</p> 	<p>C</p> 
<p>Seat Frame 2 PCS</p>	<p>Backrest 2 PCS</p>	<p>Front Leg 4 PCS</p>

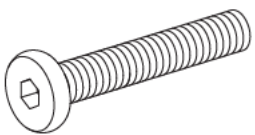
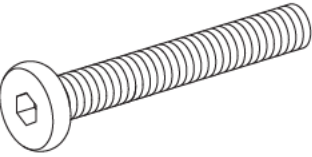

HARDWARE LIST

<p>#1</p>  <p>½" x 1. ½" L</p>	<p>#2</p>  <p>½" x 2" L</p>	<p>#3</p> 	<p>#4</p> 
<p>Short Bolt 6 PCS (Extra 1)</p>	<p>Long Bolt 8 PCS (Extra 1)</p>	<p>Flat Washer 14 PCS (Extra 1)</p>	<p>Allen Wrench 1 PC</p>

Step 1. Carefully turn seat frame (part A) upside down on a flat, soft surface, such as carpet. Attach front legs (part C) to seat frame (part A) using long bolts (part #2), flat washers (part #3) and allen wrench (part #4).

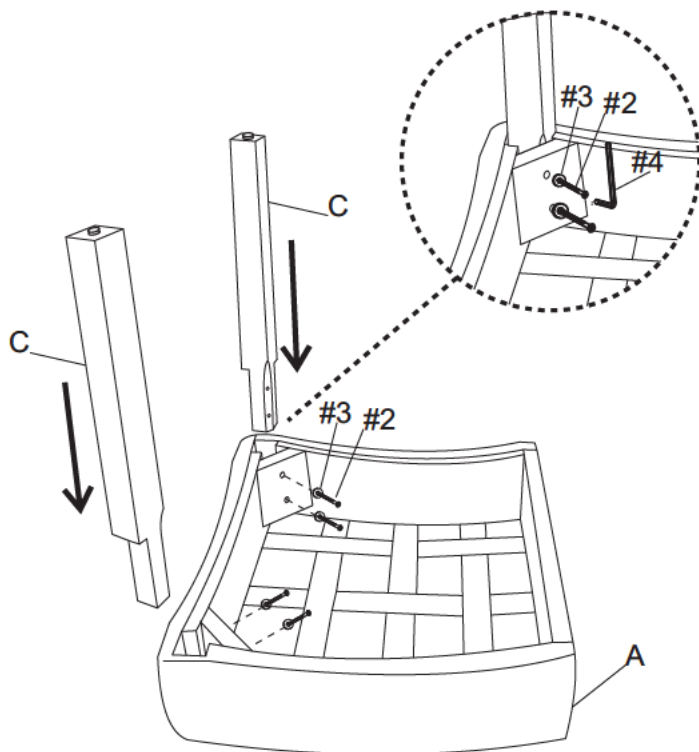
NOTE: Please fully tighten all bolts at this time.



- #2  x 4
- #3  x 4
- #4  x 1



Step 2. Lay backrest (part B) down on a flat, soft surface, such as carpet.

Attach assembled unit (parts A & C) to backrest (part B) using short bolts (part #1), flat washers (part #3) and allen wrench (part #4).

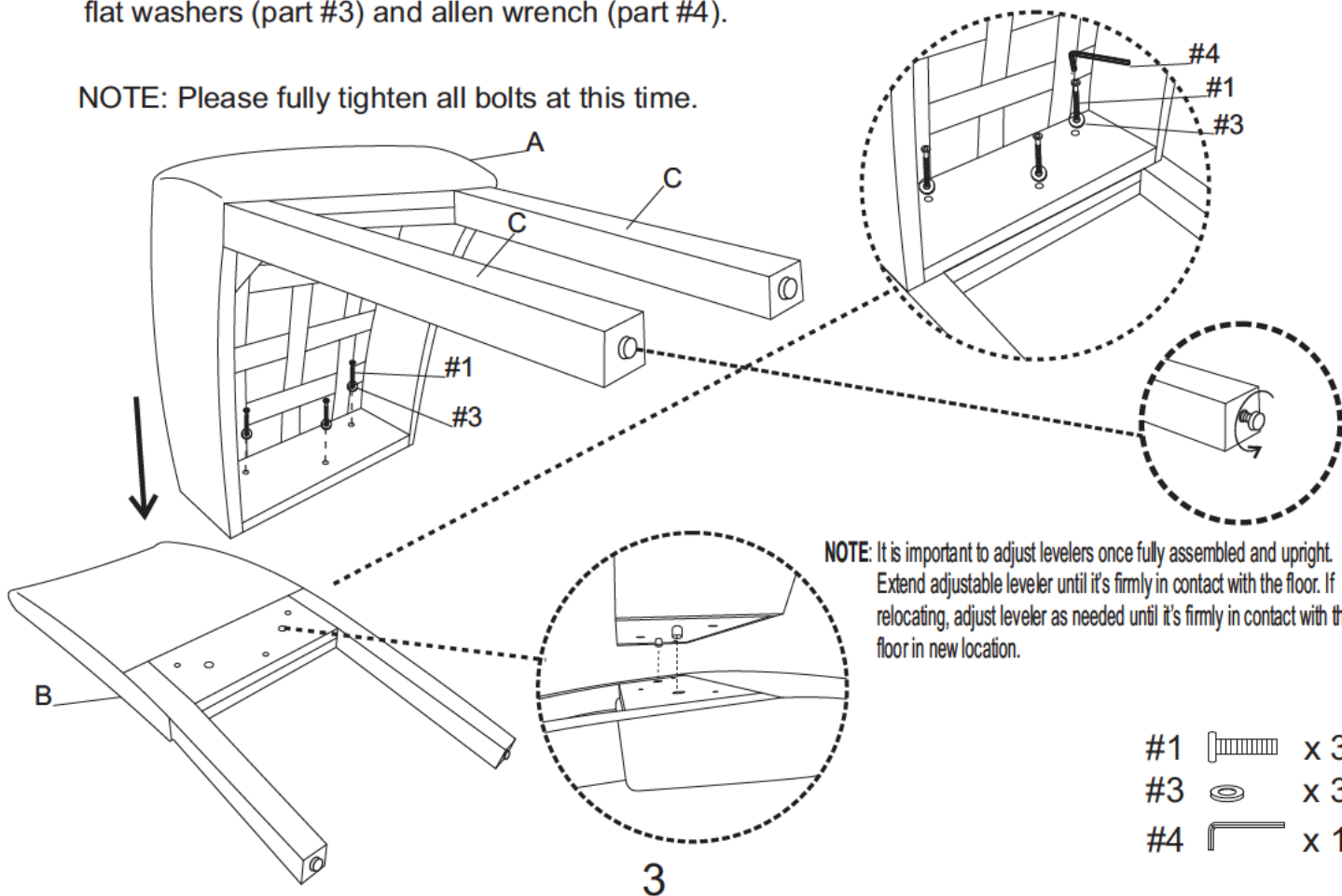
NOTE: Please fully tighten all bolts at this time.



NOTE: It is important to adjust levelers once fully assembled and upright. Extend adjustable leveler until it's firmly in contact with the floor. If relocating, adjust leveler as needed until it's firmly in contact with the floor in new location.

- #1  x 3
- #3  x 3
- #4  x 1

Step 3. Carefully turn unit upright. Repeat steps 1-2 to assemble remaining chair.

