

## ASSEMBLY INSTRUCTION

**This set is included 3 boxes if don't receive full 3 boxes please contact our customer service team**

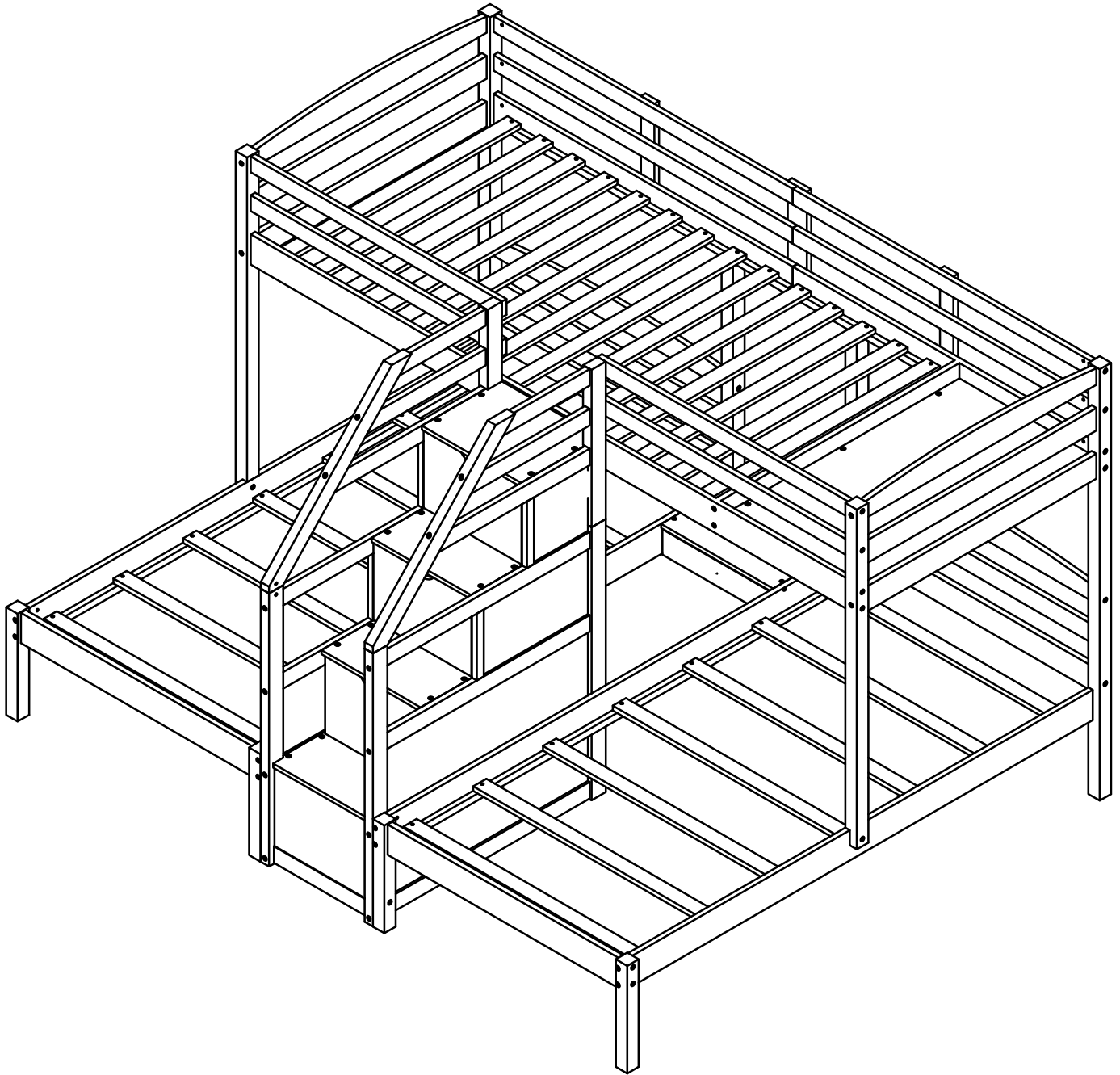

# **! SAFETY WARNINGS !**

1. This bed is designed for use only mattress (es) meeting the following specifications on the upper bunk, and lower bunk

## **Upper bed**

<b>Bed Type</b>	<b>Length</b>	<b>Width</b>	<b>Thickness</b>
<i>Twin Standard</i>	<i>74" - 75"</i>	<i>38 1/2"</i>	<i>6" max</i>
<i>Full Standard</i>	<i>74" - 75"</i>	<i>53 "- 54 "</i>	<i>6" max</i>

## **Lower bed**







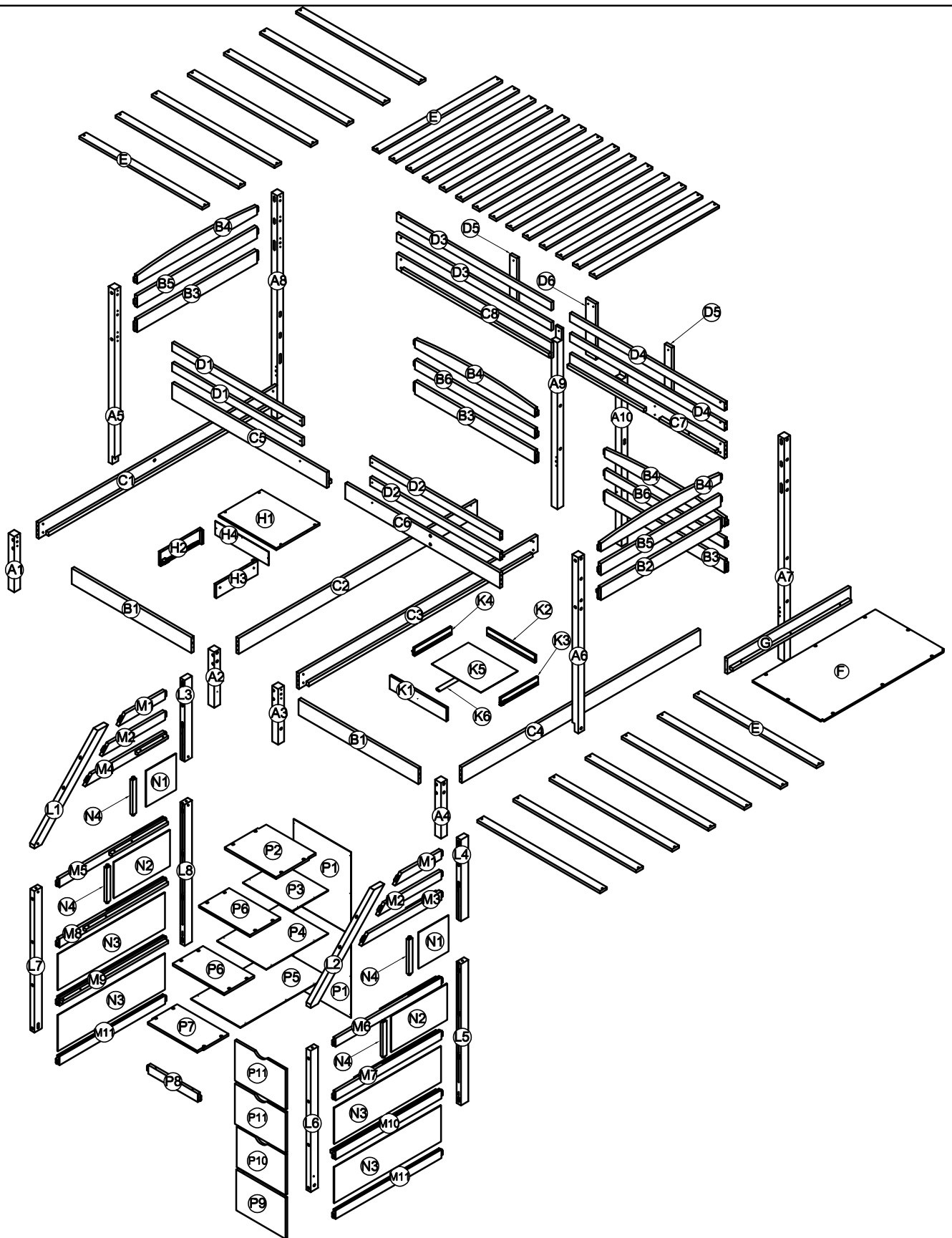



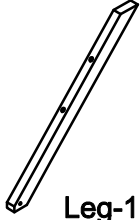
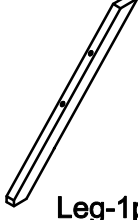

<b>Bed Type</b>	<b>Length</b>	<b>Width</b>	<b>Thickness</b>
<i>Twin Standard</i>	<i>74" - 75"</i>	<i>37 1/2"-38 1/2"</i>	<i>8" max</i>
<i>Full Standard</i>	<i>74" - 75"</i>	<i>53 "- 54 "</i>	<i>8" max</i>

2. Replacement parts, including additional guardrails, maybe obtained from any of our dealers
3. Follow the information on the warnings appearing on the upper bunk bed end structure and on the carton. Do not remove warning label from bed
4. Always use the recommended size mattresses or mattress supports, or both, to help prevent the likelihood of entrapment or falls.
5. Surface of mattress must be at least 5" (127mm) below the upper edge of guardrails
6. Do not allow children under 6 years of age to use the upper bunk.
7. Periodically check and ensure that the guardrail, ladder, and other components are in their proper position, free from damage, and that all connectors are tight.
8. Do not allow horseplay on or under the bed and prohibit jumping on the bed.
9. Always use the ladder for entering and leaving the upper bunkAlways use the ladder for entering and leaving the upper bunk.
10. Do not use substitute part. Contact the manufacture or dealer for replacement part
11. Use of a night light may provide added safety precaution for a child using the upper bunk..
12. Always use guardrails on both long sides of the upper bunk. If the bunk bed will be placed next to the wall, the guardrail that runs the full length of the bed should be placed against the wall to prevent entrapment between the bed and wall.
13. The use of water or sleep flotation mattresses is prohibited
14. **STRANGULATION HAZARD** - Never attach or hang items to any part of the bunk bed that are not designed for use with the bed; for example, but not limited to, hook, belts and jump ropes
15. Keep these instruction for future reference
16. Prohibit more than one person on upper bunk
17. We recommend assembling your bunk bed on the shipping carton to protect your floor or carpet
18. Be certain all staples are out of the box before beginning assembly on the shipping carton.

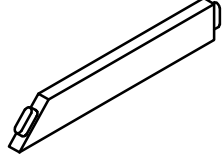
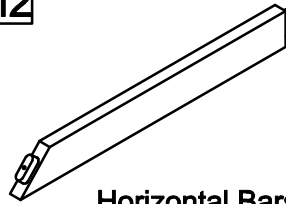
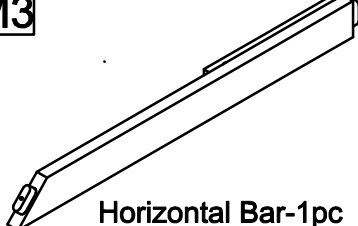
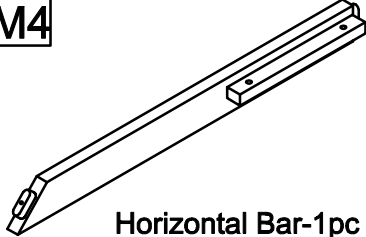
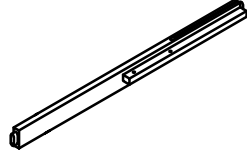

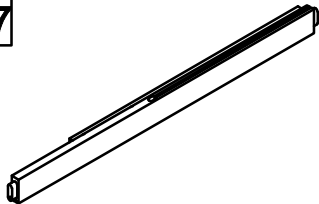
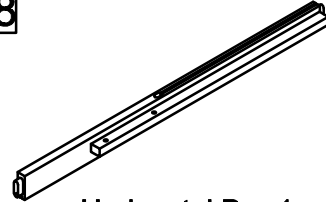
# ASSEMBLY INSTRUCTION



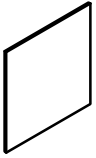
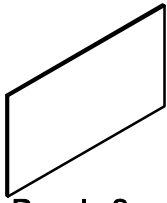



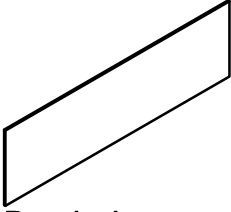

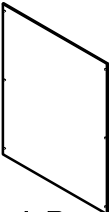
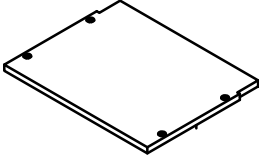
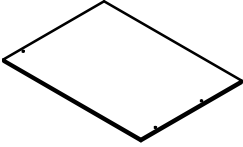
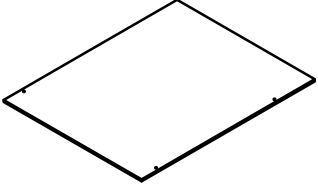
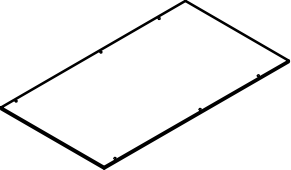
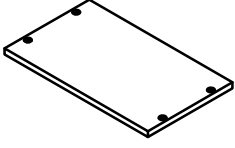
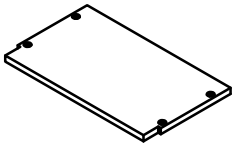
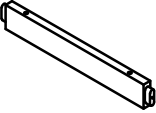
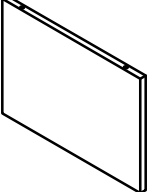
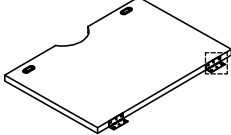
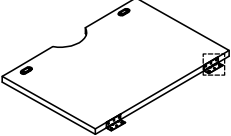
# Part List (Box 1-

<p><b>L1</b></p>  <p>Leg-1pc</p>	<p><b>L2</b></p>  <p>Leg-1pc</p>	<p><b>L3</b></p>  <p>Leg-1pc</p>
<p><b>L4</b></p>  <p>Leg-1pc</p>	<p><b>L5</b></p>  <p>Leg-1pc</p>	<p><b>L6</b></p>  <p>Leg-1pc</p>
<p><b>L7</b></p>  <p>Leg-1pc</p>	<p><b>L8</b></p>  <p>Leg-1pc</p>	<p><b>M1</b></p>  <p>Horizontal Bars-2pcs</p>
<p><b>M2</b></p>  <p>Horizontal Bars-2pcs</p>	<p><b>M3</b></p>  <p>Horizontal Bar-1pc</p>	<p><b>M4</b></p>  <p>Horizontal Bar-1pc</p>
<p><b>M5</b></p>  <p>Horizontal Bar-1pc</p>	<p><b>M6</b></p>  <p>Horizontal Bar-1pc</p>	<p><b>M7</b></p>  <p>Horizontal Bar-1pc</p>
<p><b>M8</b></p>  <p>Horizontal Bar-1pc</p>	<p><b>M9</b></p>  <p>Horizontal Bar-1pc</p>	<p><b>M10</b></p>  <p>Horizontal Bar-1pc</p>
<p><b>M11</b></p>  <p>Horizontal Bars-2pcs</p>	<p><b>N1</b></p>  <p>Panels-2pcs</p>	<p><b>N2</b></p>  <p>Panels-2pcs</p>

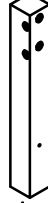
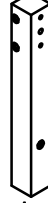
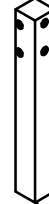
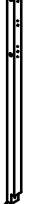

# Part List (Box 1-

<b>N3</b>  Panels-4pcs	<b>N4</b>  Vertical Bars-4pcs	<b>P1</b>  Back Panels-2pcs
<b>P2</b>  Top Panel-1pc	<b>P3</b>  Top Panel-1pc	<b>P4</b>  Top Panel-1pc
<b>P5</b>  Top Panel-1pc	<b>P6</b>  Top Panels-2pcs	<b>P7</b>  Top Panel-1pc
<b>P8</b>  Horizontal Bar-1pc	<b>P9</b>  Front Panel-1pc	<b>P10</b>  Door-1pc
<b>P11</b>  Doors-2pcs		

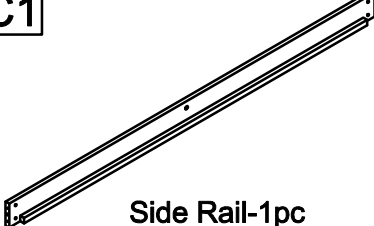
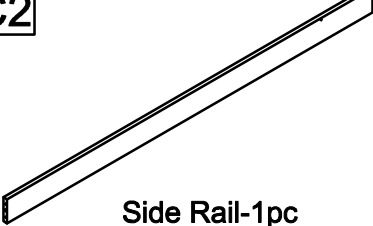
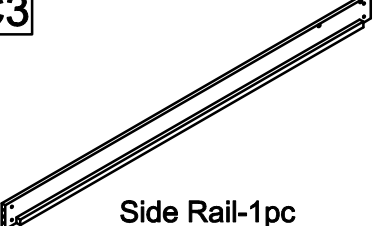
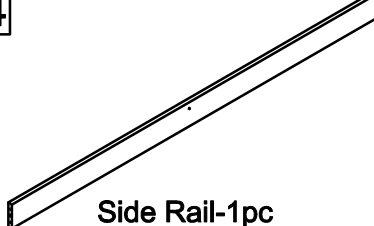
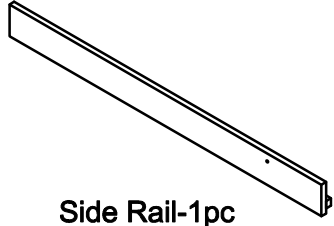
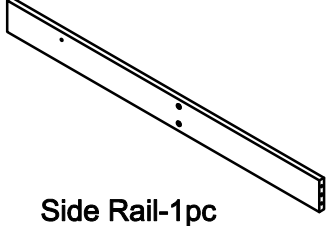
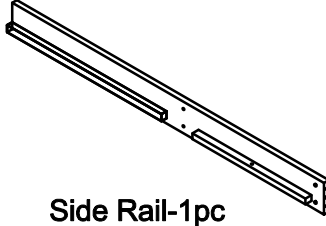
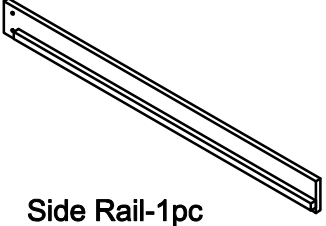
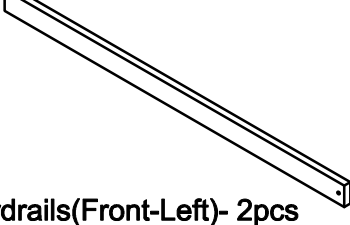
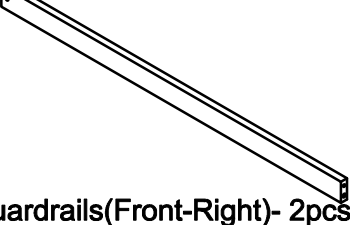
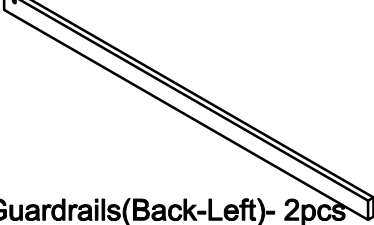

# Part List & Hardware List (Box 2)

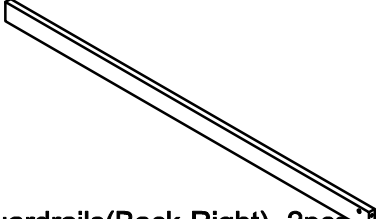
<p><b>A1</b></p>  <p>Leg-1pc</p>	<p><b>A2</b></p>  <p>Leg-1pc</p>	<p><b>A3</b></p>  <p>Leg-1pc</p>
<p><b>A4</b></p>  <p>Leg-1pc</p>	<p><b>A5</b></p>  <p>Leg-1pc</p>	<p><b>A6</b></p>  <p>Leg-1pc</p>
<p><b>A7</b></p>  <p>Leg-1pc</p>	<p><b>A8</b></p>  <p>Leg-1pc</p>	<p><b>A9</b></p>  <p>Leg-1pc</p>
<p><b>A10</b></p>  <p>Leg-1pc</p>	<p><b>C1</b></p>  <p>Side Rail-1pc</p>	<p><b>C2</b></p>  <p>Side Rail-1pc</p>
<p><b>C3</b></p>  <p>Side Rail-1pc</p>	<p><b>C4</b></p>  <p>Side Rail-1pc</p>	<p><b>C5</b></p>  <p>Side Rail-1pc</p>
<p><b>C6</b></p>  <p>Side Rail-1pc</p>	<p><b>C7</b></p>  <p>Side Rail-1pc</p>	<p><b>C8</b></p>  <p>Side Rail-1pc</p>
<p><b>D1</b></p>  <p>Guardrails(Front-Left)- 2pcs</p>	<p><b>D2</b></p>  <p>Guardrails(Front-Right)- 2pcs</p>	<p><b>D3</b></p>  <p>Guardrails(Back-Left)- 2pcs</p>

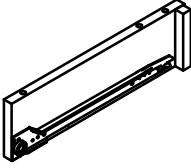
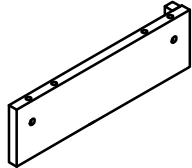
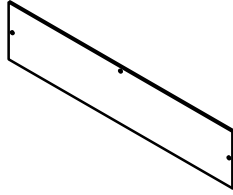
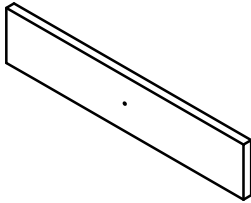
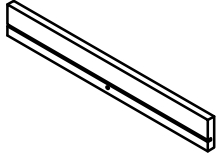
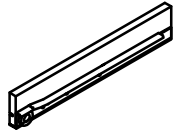
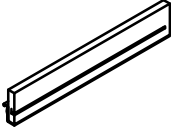
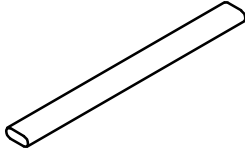



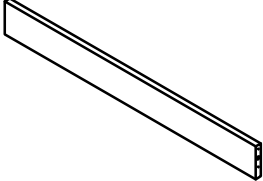
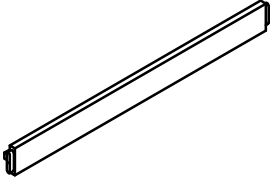
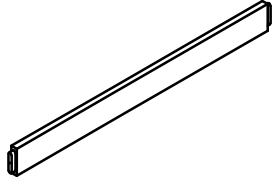
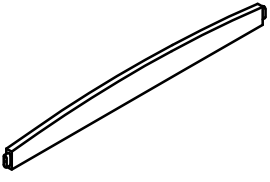
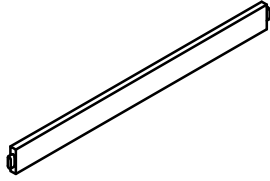
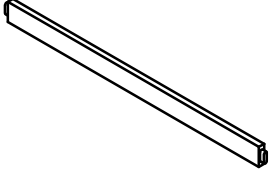

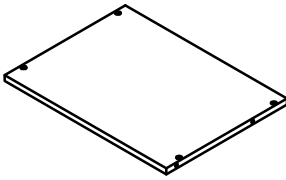
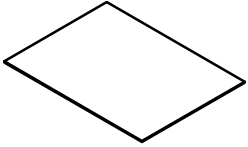
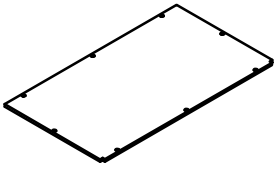
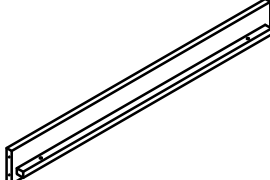



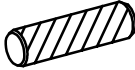

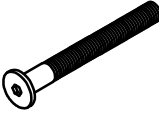



# Part List & Hardware List (Box 2)

<p><b>D4</b></p>  <p>Guardrails(Back-Right)- 2pcs</p>	<p><b>D5</b></p>  <p>Rails- 2pcs</p>	<p><b>D6</b></p>  <p>Rail- 1pc</p>
<p><b>H2</b></p>  <p>Side panel-1pc</p>	<p><b>H3</b></p>  <p>Side panel-1pc</p>	<p><b>H4</b></p>  <p>Back panel-1pc</p>
<p><b>K1</b></p>  <p>Drawer-Front panel-1pc</p>	<p><b>K2</b></p>  <p>Drawer-Back panel-1pc</p>	<p><b>K3</b></p>  <p>Drawer-Side panel-1pc</p>
<p><b>K4</b></p>  <p>Drawer-Side panel-1pc</p>	<p><b>K6</b></p>  <p>Drawer-Support Bottom panel-1pc</p>	

# Part List (Box 3)

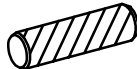
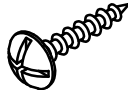
<b>B1</b>  Wood Bars-2pcs	<b>B2</b>  Wood Bar-1pc	<b>B3</b>  Wood Bars-3pcs
<b>B4</b>  Wood Bars-4pcs	<b>B5</b>  Wood Bars-2pcs	<b>B6</b>  Wood Bars-2pcs
<b>E</b>  Slats-28pcs	<b>H1</b>  Top panel-1pc	<b>K5</b>  Drawer-Bottom panel-1pc
<b>F</b>  Top panel-1pc	<b>G</b>  Center Frame-1pc	

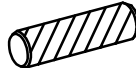
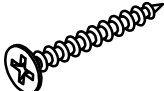
# Hardware List(Box 2)

<p>1</p>  <p>Ø10 x 40 mm Wood dowel 24pcs</p>	<p>2</p>  <p>Screws 1/4" x80 34pcs</p>	<p>3</p>  <p>Screws 1/4" x70 16pcs</p>
<p>4</p>  <p>Ø1/4" x 100 mm Hex-Head bolts 32pcs</p>	<p>5</p>  <p>Ø1/4" x 13 mm Horizontal-Hole bolts 40pcs</p>	<p>6</p>  <p>Allen Key 1pc</p>
<p>7</p>  <p>Ø1/4" x 35 mm Hex-Head bolts 8pcs</p>	<p>8</p>  <p>Ø1/4" x 15 mm Canopy head though -2cs</p>	<p>9</p>  <p>M4 x 30 mm Wood Screws 69pcs</p>
<p>10</p>  <p>Screws 1/4" x30 14pcs</p>	<p>11</p>  <p>Screws 1/4" x50 6pcs</p>	<p>12</p>  <p>Ø1/4" x 25 mm Hex-Head bolts 24pcs</p>
<p>13</p>  <p>Ø1/4" x 60 mm(Đầu 12) Hex-Head bolts 10pcs</p>	<p>14</p>  <p>Ø8 x 30 mm Wood dowel 8pcs</p>	<p>15</p>  <p>M4 x 15 mm Wood Screws 14pcs</p>
<p>16</p>  <p>Ø1/6" x 25 mm Hex-Head bolts 1pcs</p>	<p>17</p>  <p>Handle Wood 1pcs</p>	<p>18</p>  <p>Ø12 x 70 mm Wood dowel 4pcs</p>
<p>19</p>  <p>M3 x 12 mm Wood Screws 18pcs</p>	<p>20</p>  <p>Pan head Screw M4x15 12pcs</p>	

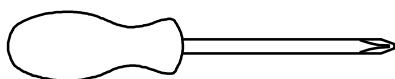



**Assembly Tools Required (Not Included)**

# STEP 1: Following below illustration Assembly Bottom bed's Footboard .

-Using hardware #2 and dowel #1 connect A1,A2 legs with B1 Woodbar

-Using hardware #2 and dowel #1 connect A3,A4 legs with B1 Woodbar

2	1
	
4x2(pcs)	2x2(pcs)

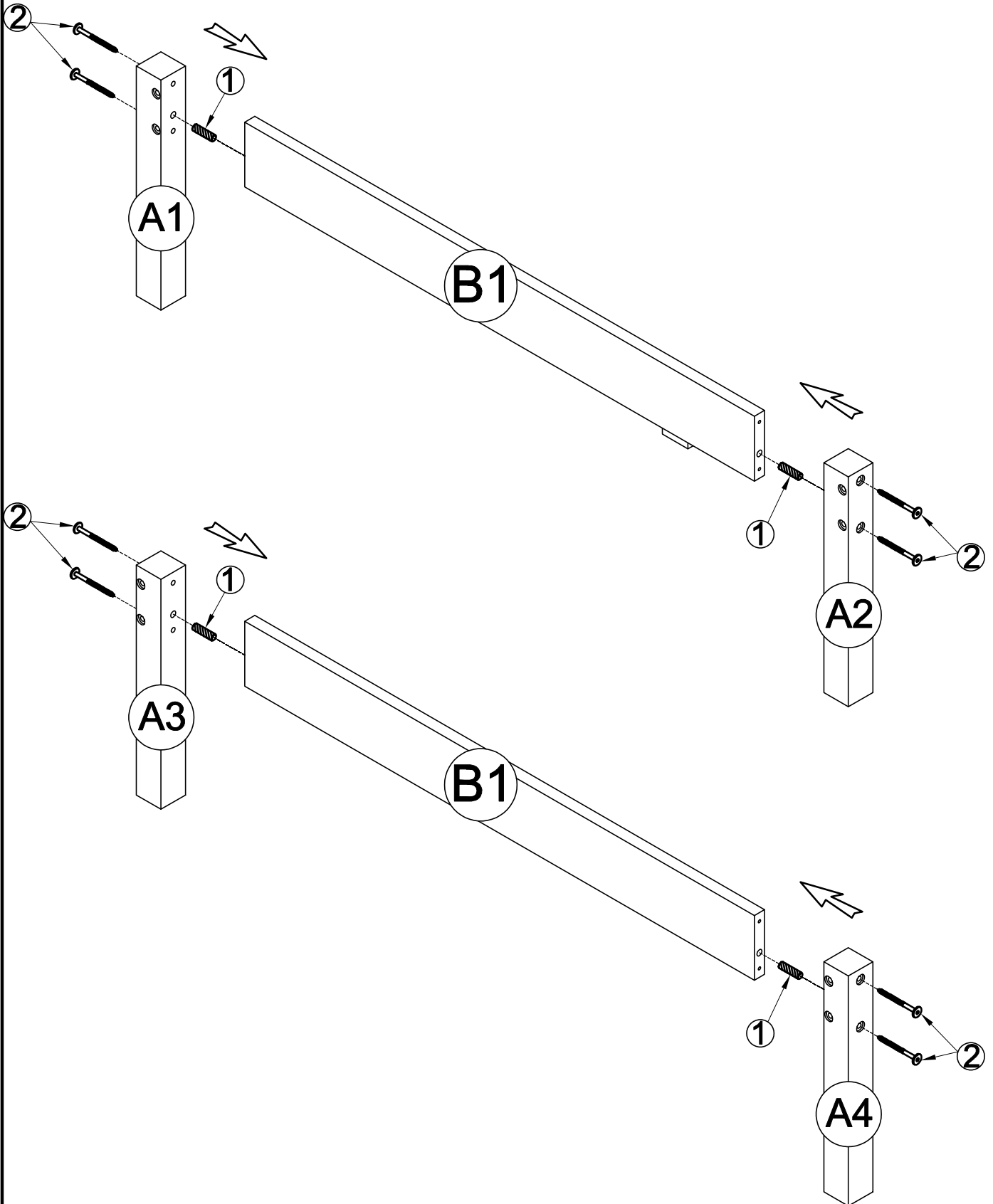

# STEP 2: Following below illustration Assembly Bottom bed's Headboard .

-Using hardware #3 connect B3,B4,B6 Woodbar with A8,A9 Legs

-Using hardware #3 connect B3,B4,B6 Woodbar with A7,A10 Legs

3



4x2(pcs)

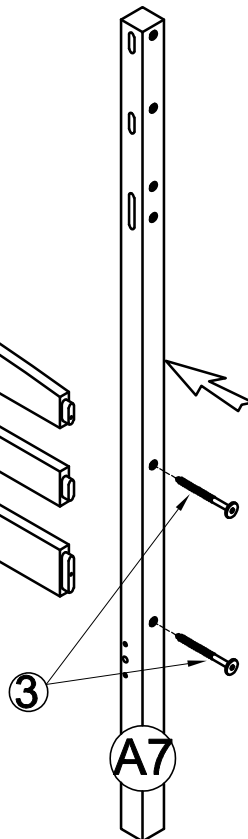
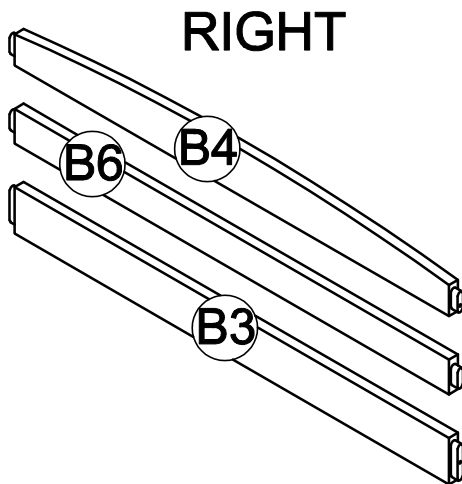
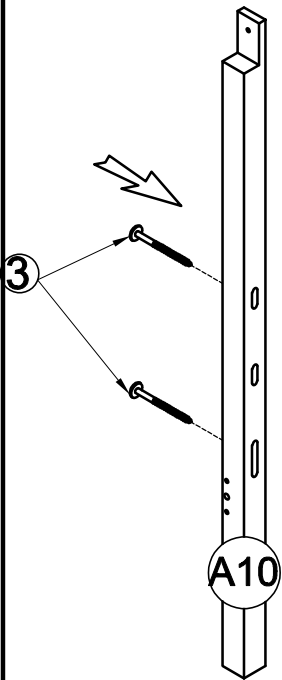
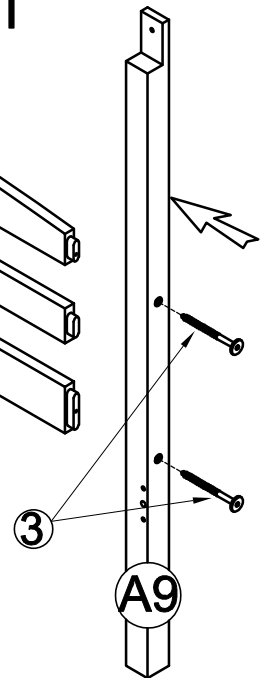
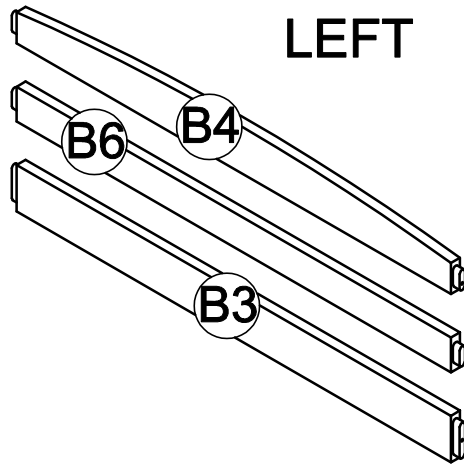
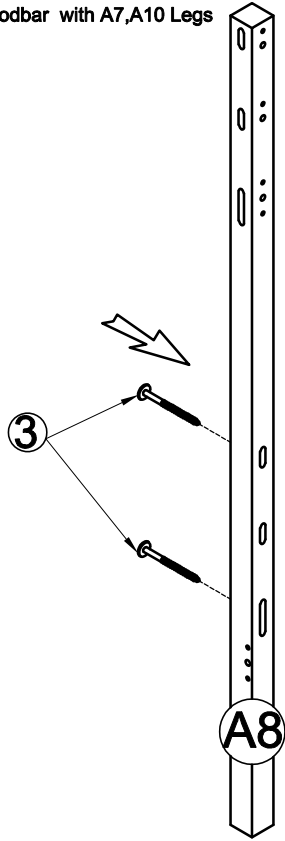

# STEP 3: Following below illustration

-Using hardware #3 connect B3,B4,B5 Woodbar with A5 Leg

-Using hardware #3 connect B2,B4,B5 Woodbar with A6 Leg

3



4(pcs)

LEFT

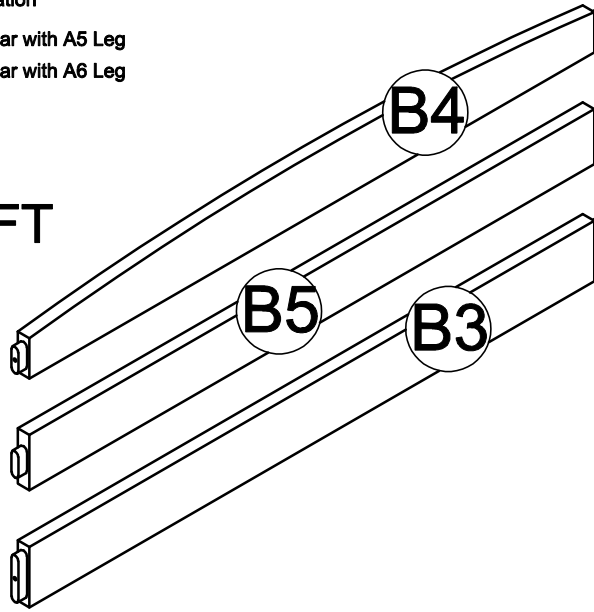
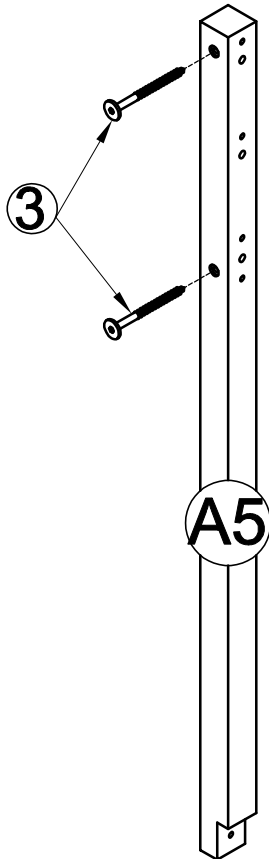

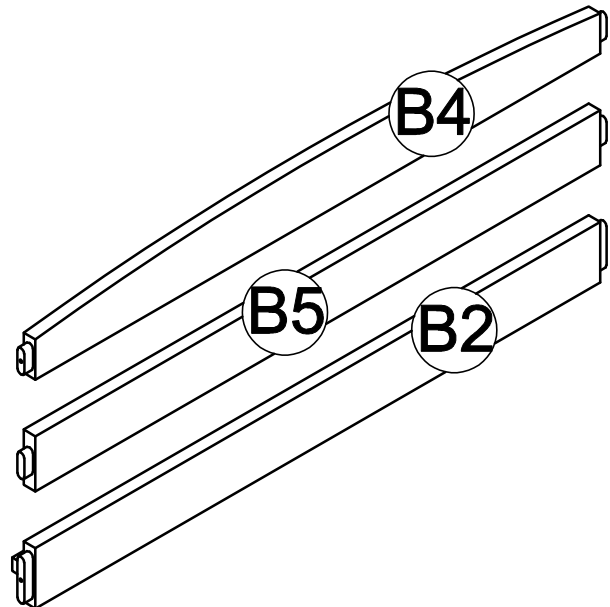
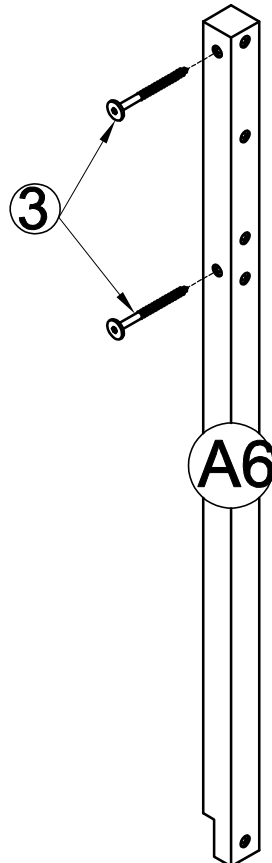

RIGHT

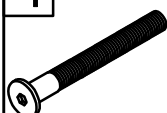

# STEP 4: Following below illustration Using hardware #4, #5 and dowel #1

follow detail view to Assembly Bottom bed's Headboard (Completed on step 2) and Footboard (Completed on step 1) with siderail C3,C4.Look at detail view for more detail

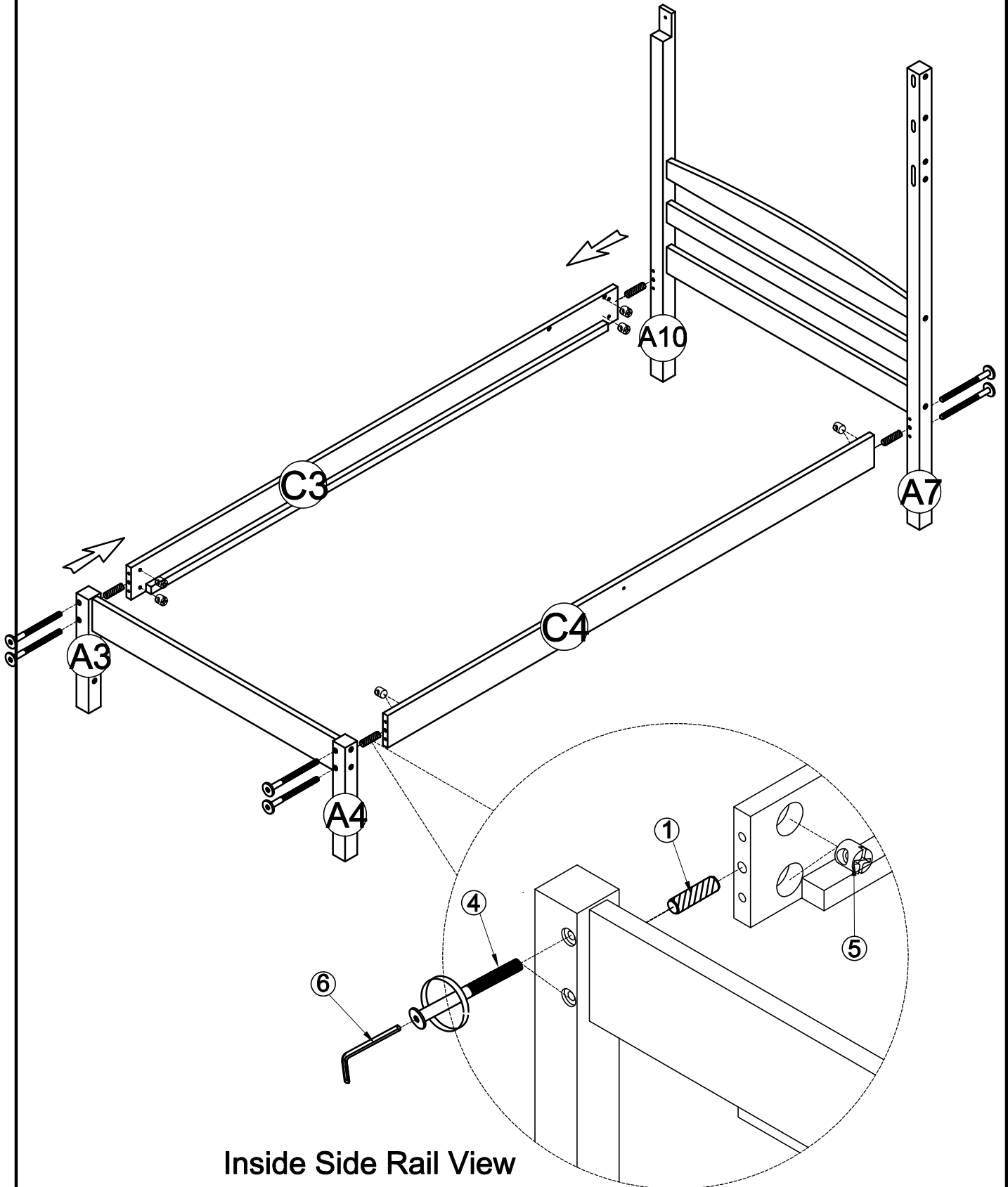

5		4		1	
8(pcs)		8(pcs)		4(pcs)	



Inside Side Rail View

# STEP 5: Following below illustration

-Using hardware #3,#7,#8 connect Frame(completed on step 4 ) withFrame (completed on step 3)

8	7	3
		
1(pcs)	1(pcs)	2(pcs)

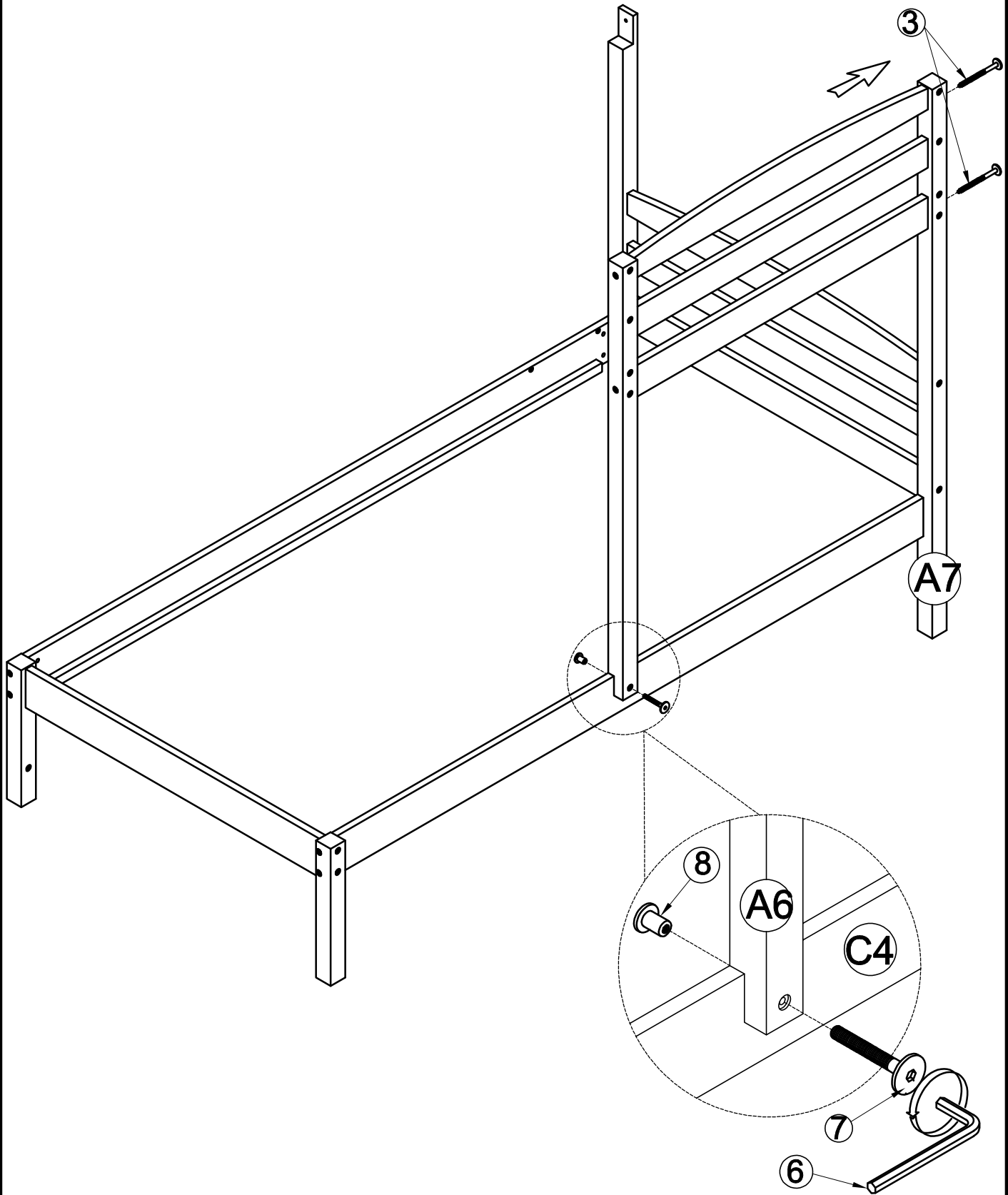

# STEP 6: Following below illustration:

-Screw 7 slats E with Side Rail C3,C4 by using hardware #9.

-Look at detail view for more detail

9



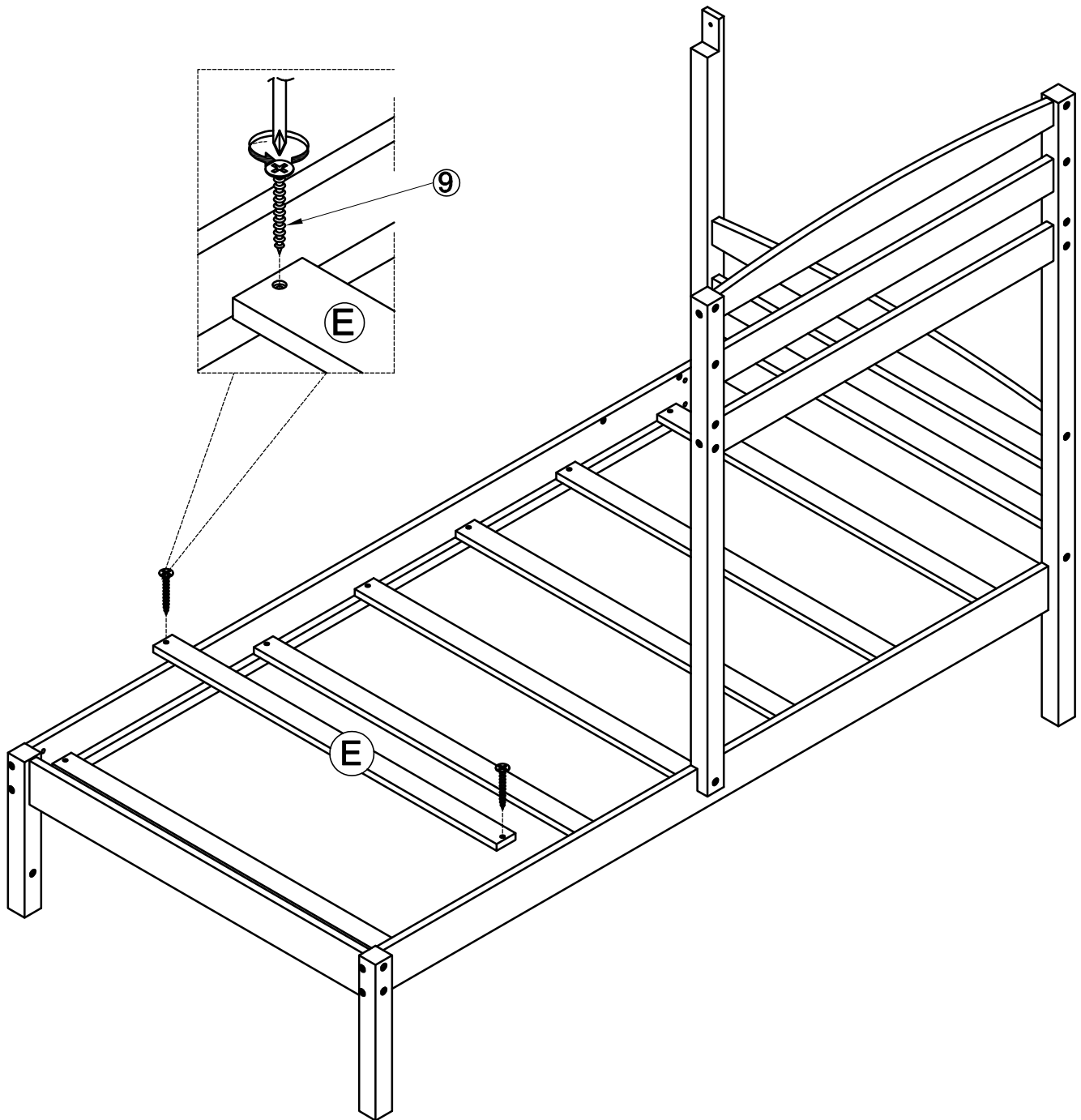

14(pcs)

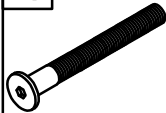

# STEP 7: Following below illustration Using hardware #4, #5 and dowel #1

follow detail view to Assembly Bottom bed's Headboard (Completed on step 2) and Footboard (Completed on step 1) with siderail C1,C2.Look at detail view for more detail

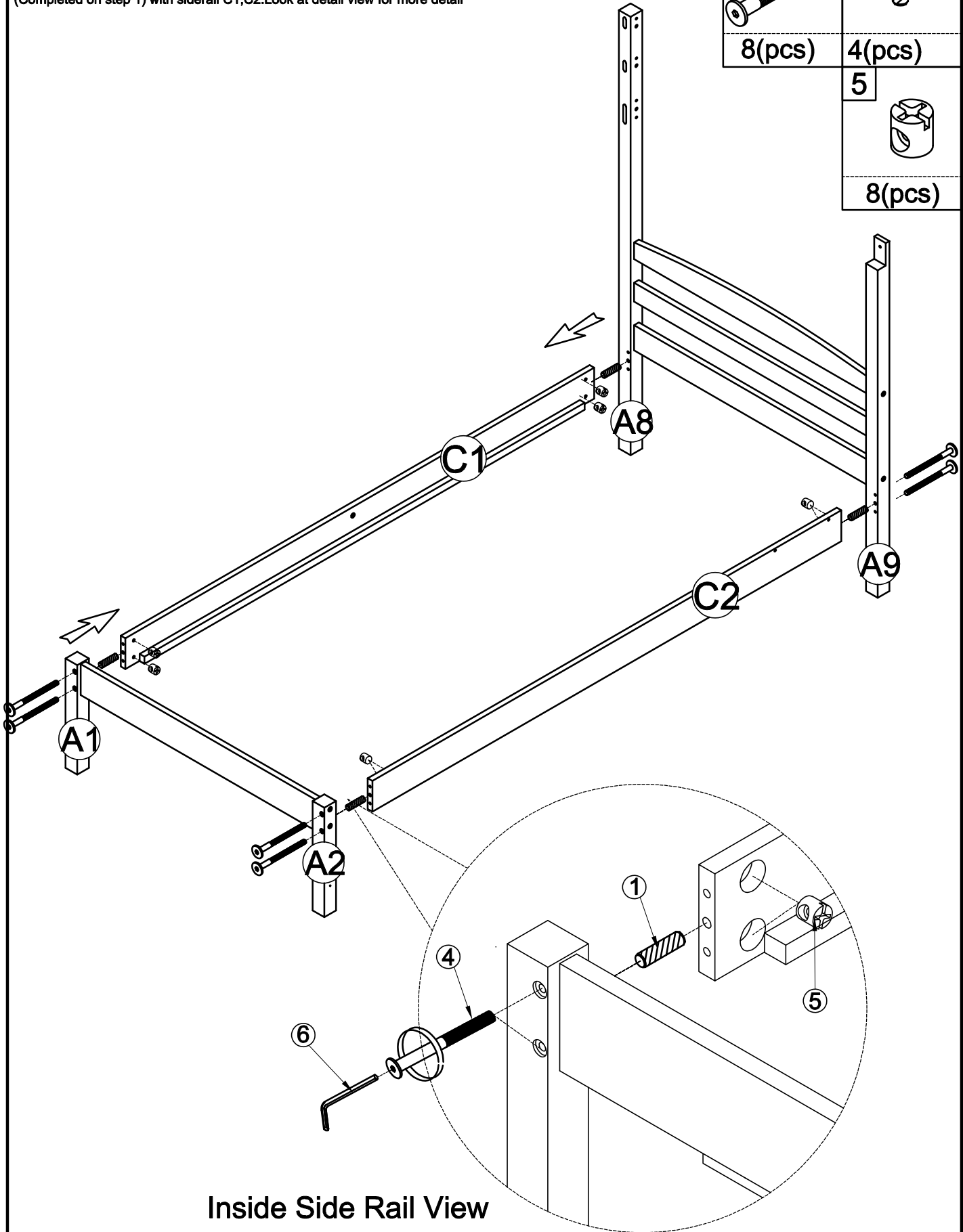

4	1
	
8(pcs)	4(pcs)
	5
	
	8(pcs)



Inside Side Rail View

# STEP 8: Following below illustration

-Using hardware #3,#7,#8 connect Frame(completed on step 7 ) withFrame (completed on step 3)

8	7	3
		
1(pcs)	1(pcs)	2(pcs)

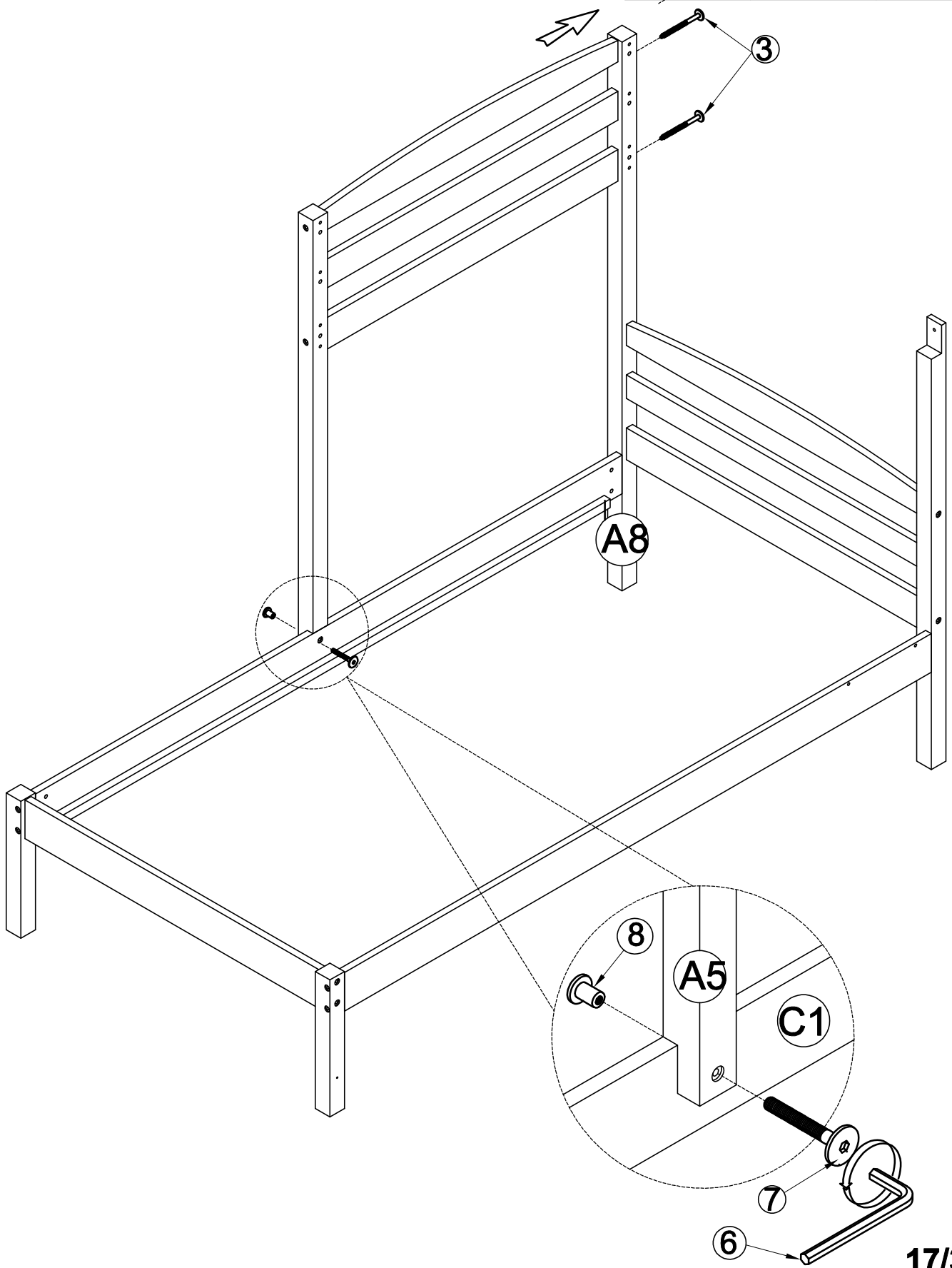

# STEP 9: Following below illustration:

-Screw 7slats E with Side Rail C1,C2 by using hardware #9.

-Look at detail view for more detail

9



14(pcs)

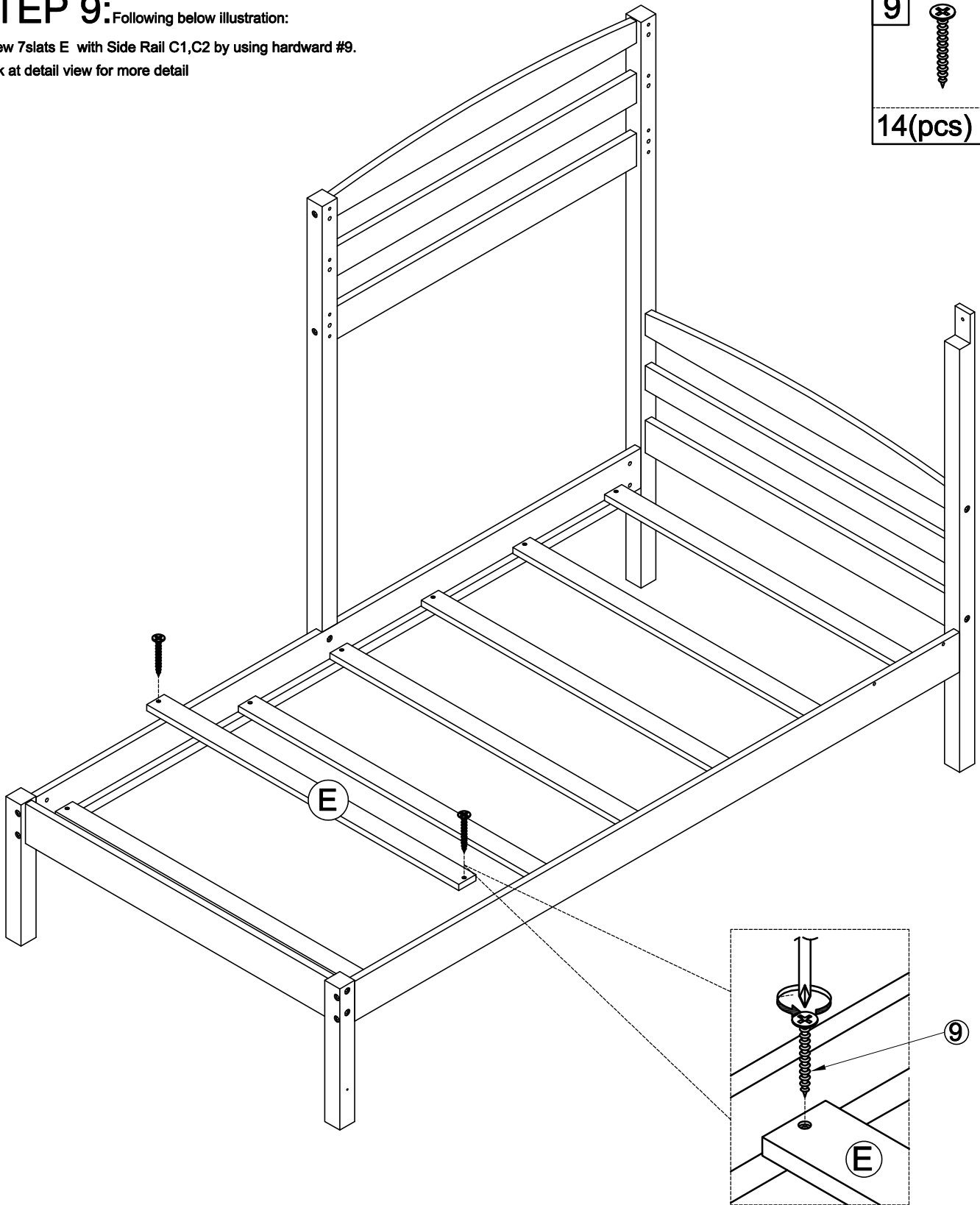

# STEP 10: Following below illustration:

- Using hardware #10 connect Side Rails C7,C8 and Guardrails D3(x2),D4(x2) with Rails D5(x2),D6
- Look at detail view for more detail

10



12(pcs)

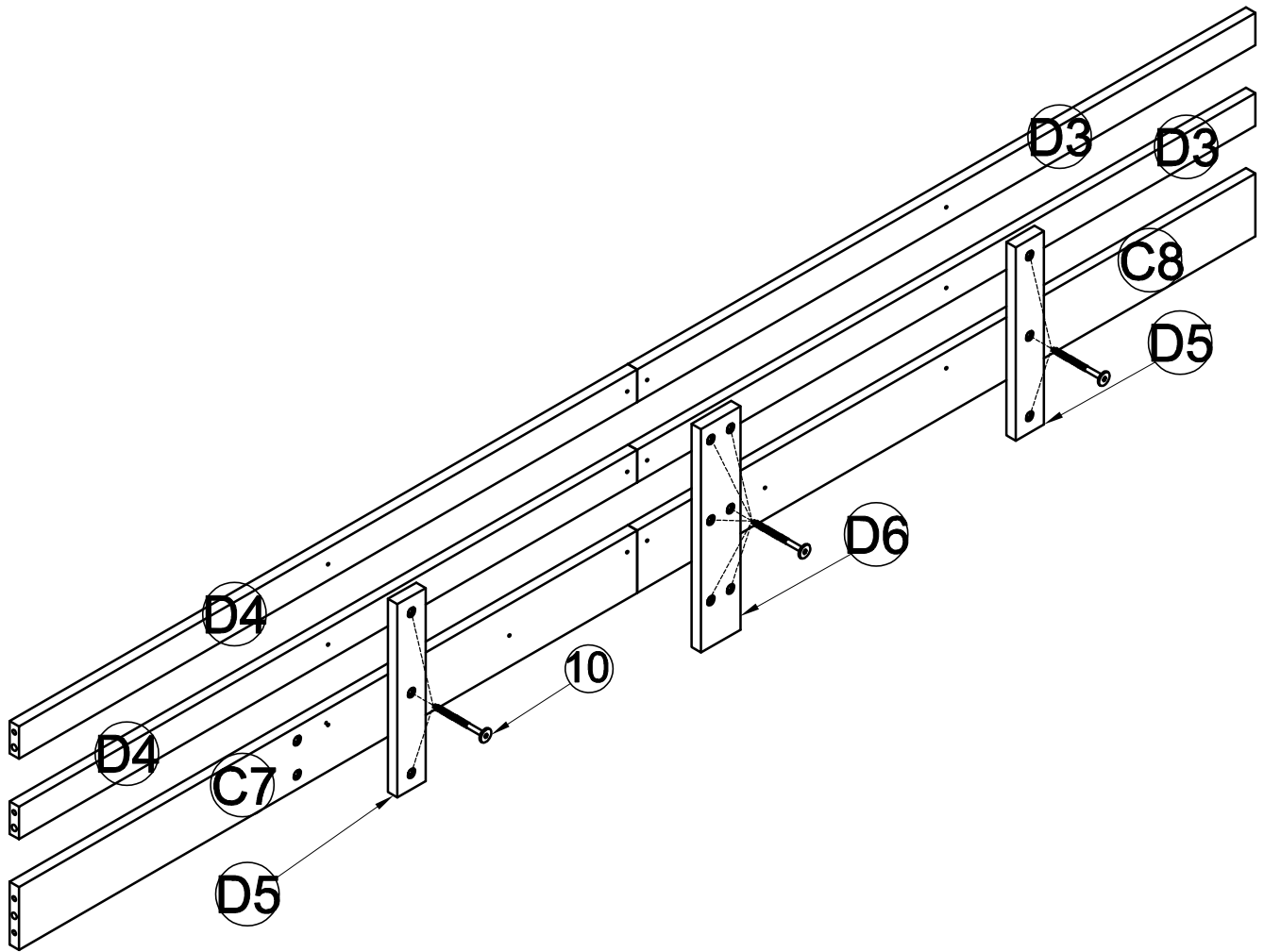

# STEP 11: Following below illustration:

-Using hardware #4,#5,#10 and dowel #1 connect Frame (Completed on step 9) and Frame (Completed on step 6) with Frame (Completed on step 10), Side Rail C5,C5 and Guardrails D1(x2),D2(x2) .  
Look at detail view for more detail

4	1
16(pcs)	12(pcs)
5	10
16(pcs)	2(pcs)

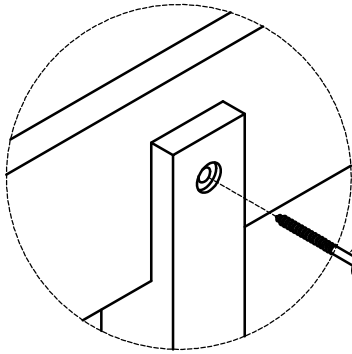

10

## Detail 2 Back View

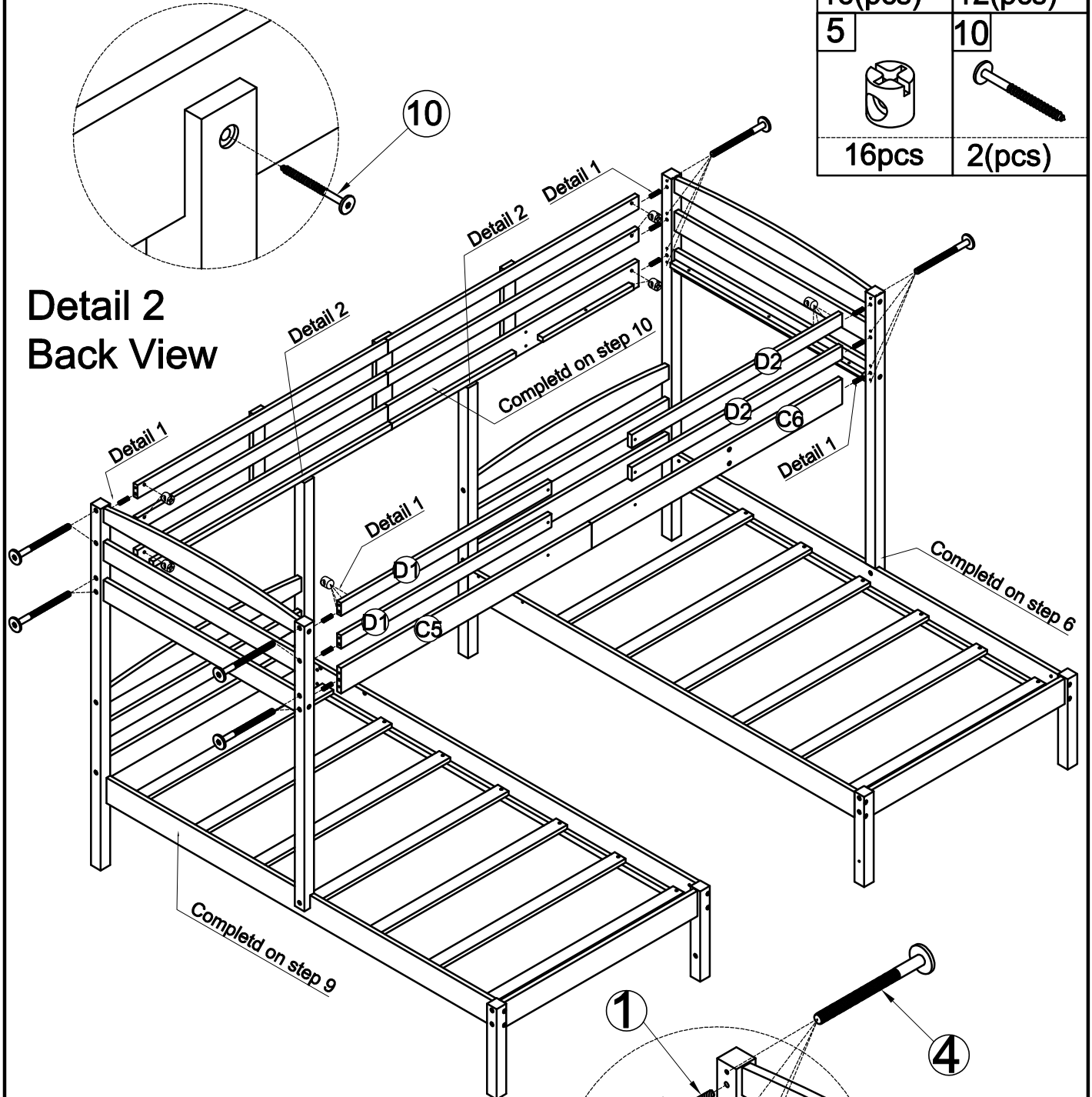

## Detail 1

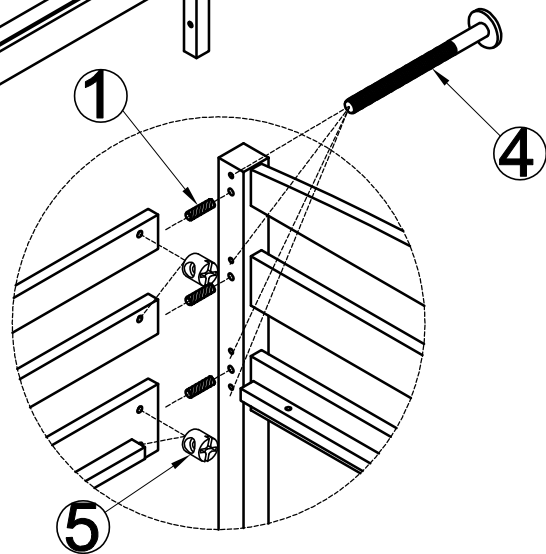

# STEP 12: Following below illustration

-Using hardware #11 connect Frame(completed on step 11 ) with G Frame

11



4(pcs)

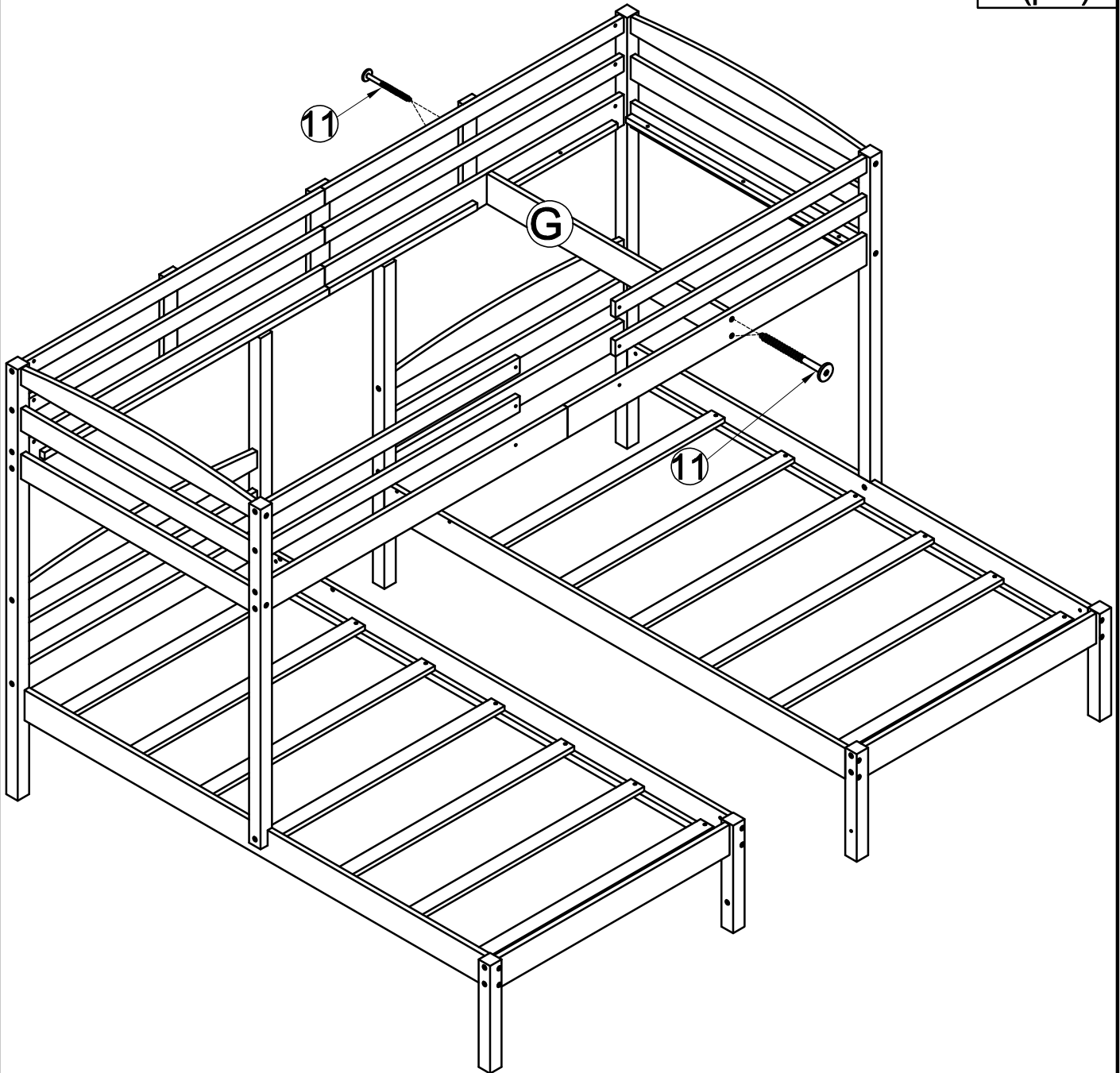

# STEP 13: Following below illustration

-Using hardware #12 connect Frame(completed on step 12 ) with Panel F

12





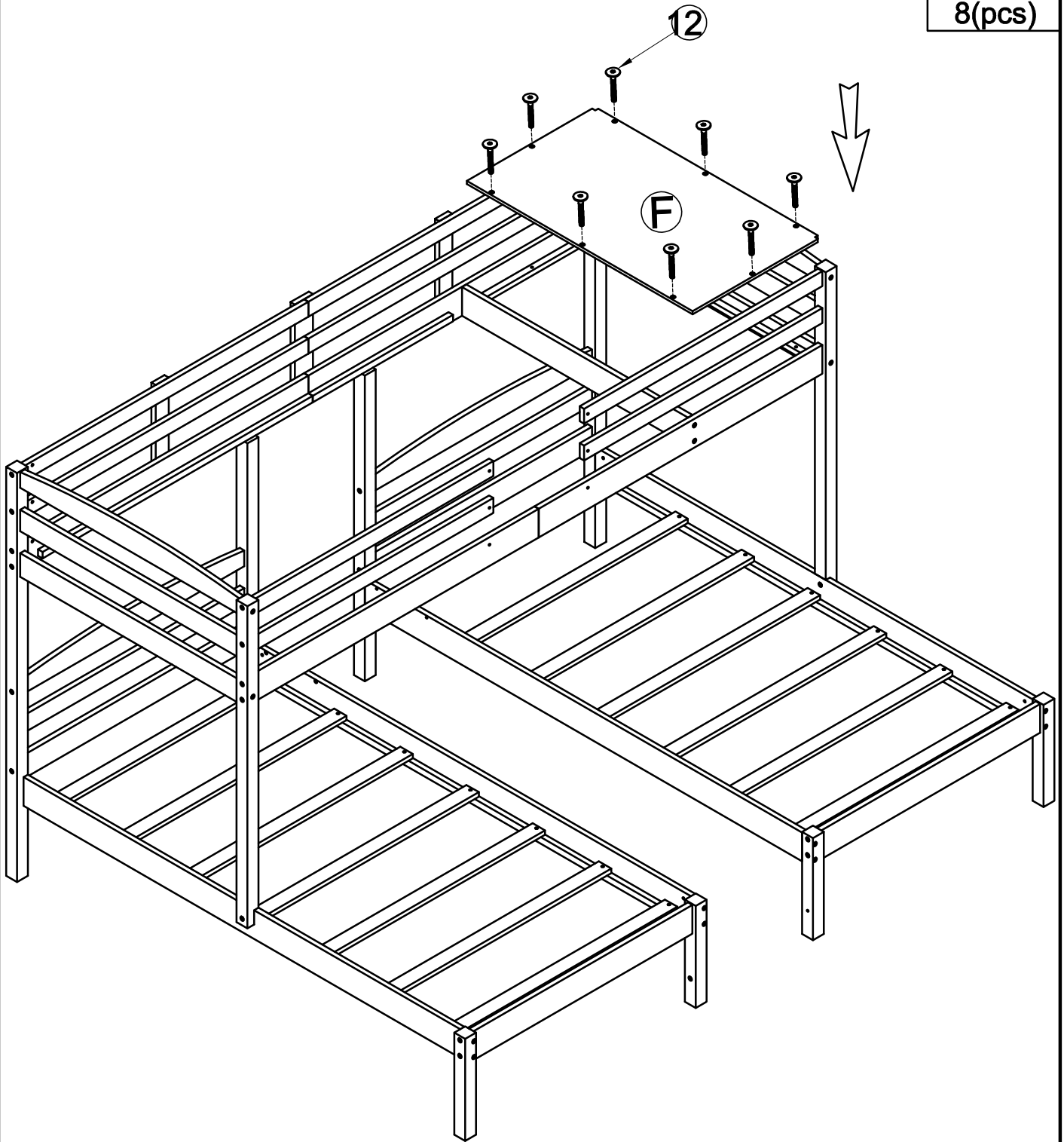

8(pcs)

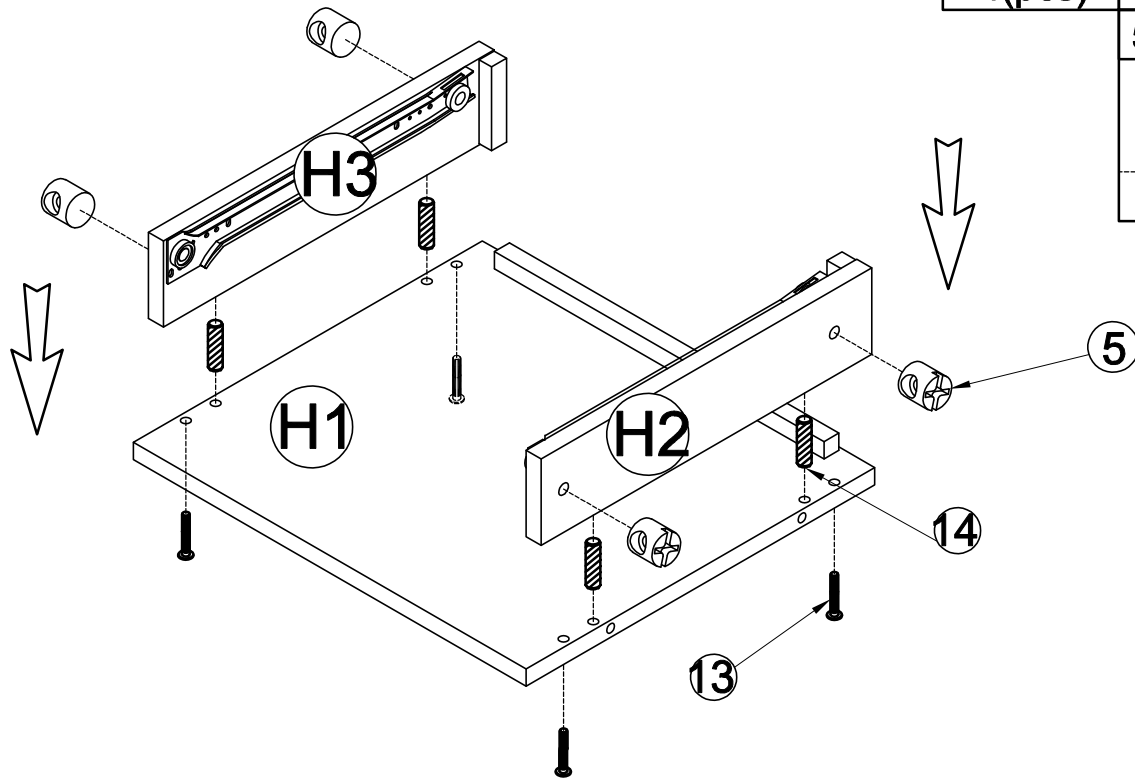

# STEP 14-1: Following below illustration:

-Using hardward #5,#13 and dowel #14 to connect H2,H3 panels with H1 panel



13		14	
4(pcs)		4(pcs)	
		5	
		4pcs	

# STEP 14-2: Following below illustration:

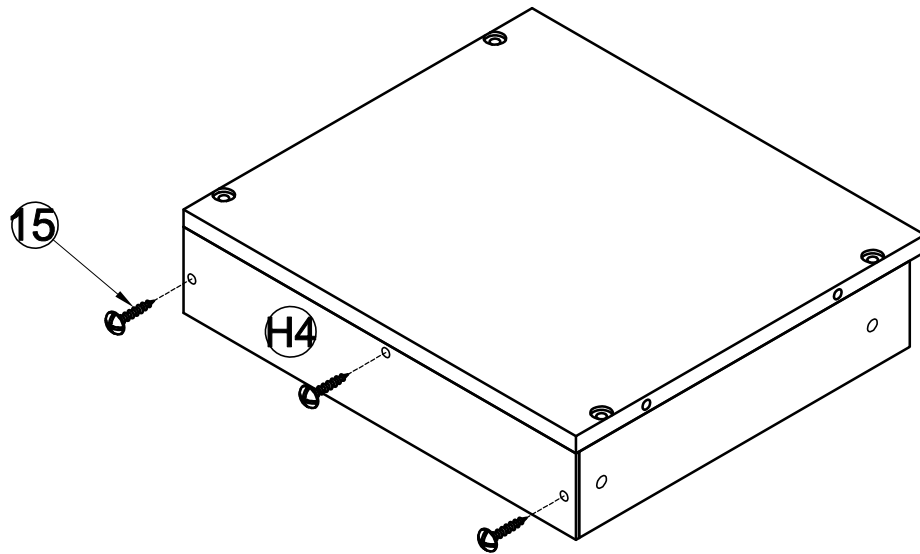

-Using hardward #15 to connect Frame(completed on step 14-1) with Back panel H4



15	
3(pcs)	

# STEP 15: Following below illustration:

-Using hardward #5,#13 to connect Frame (completed on step 13) with Frame (completed on step 14-2)

5	13
	
4pcs	4(pcs)

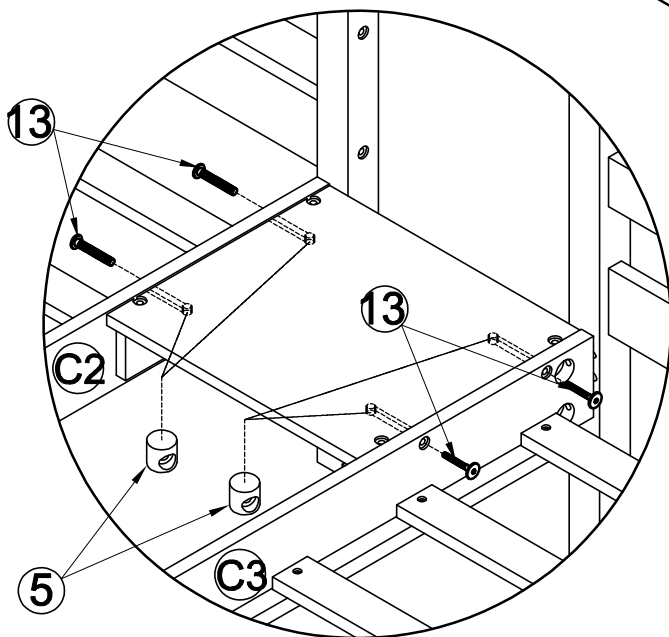
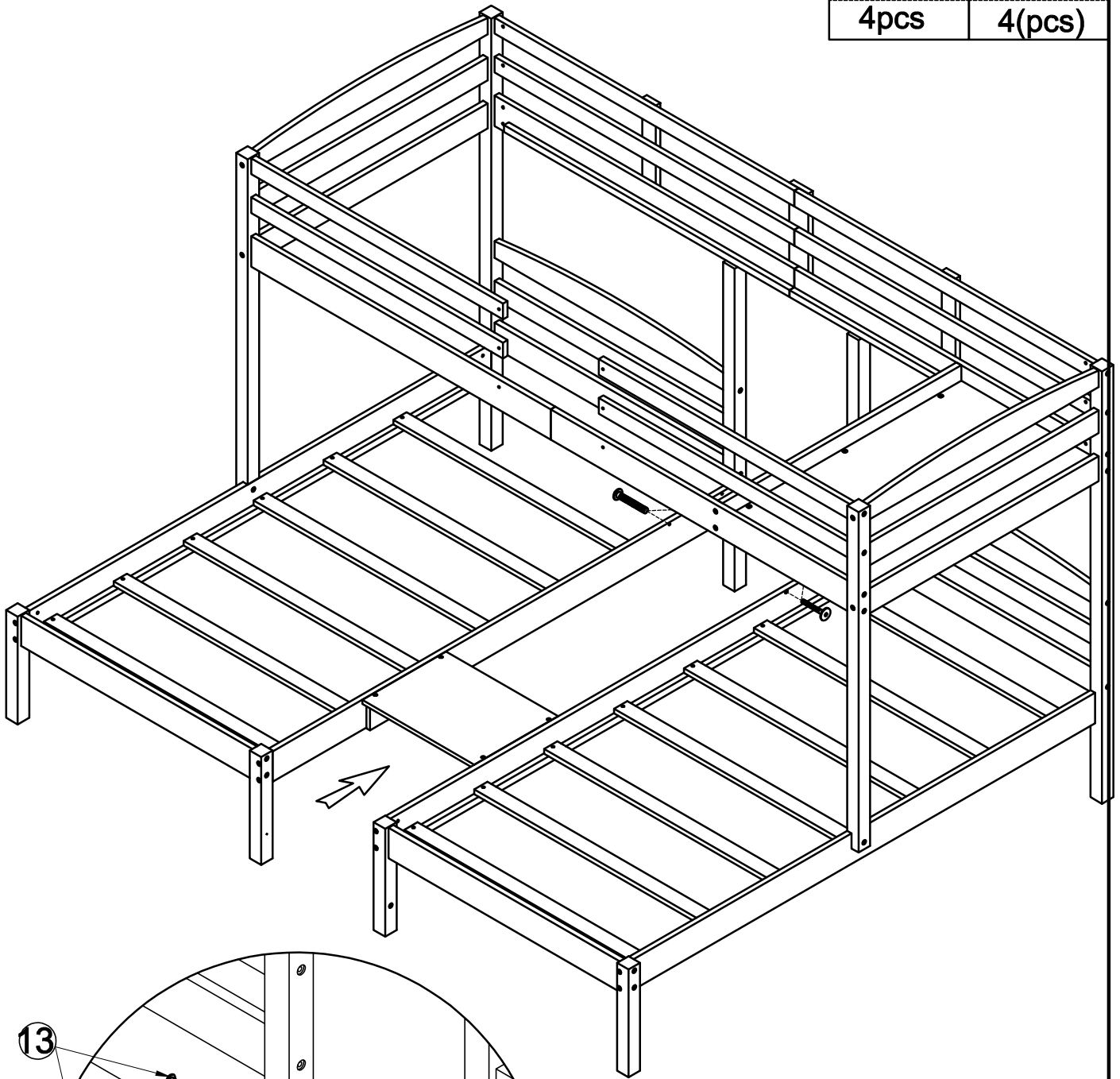

**STEP 16-1:**

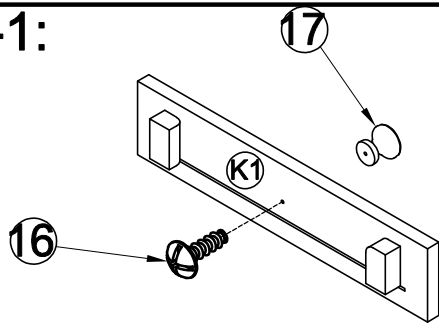

17

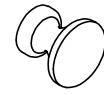

1(pcs)

16



1(pcs)

**STEP 16-2:**

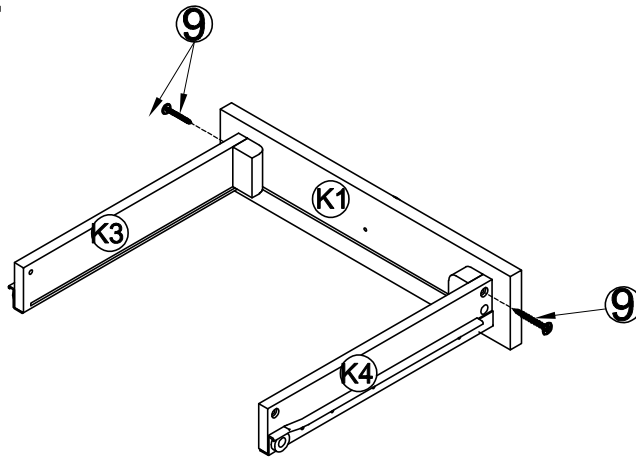

9



2(pcs)

**STEP 16-3:**

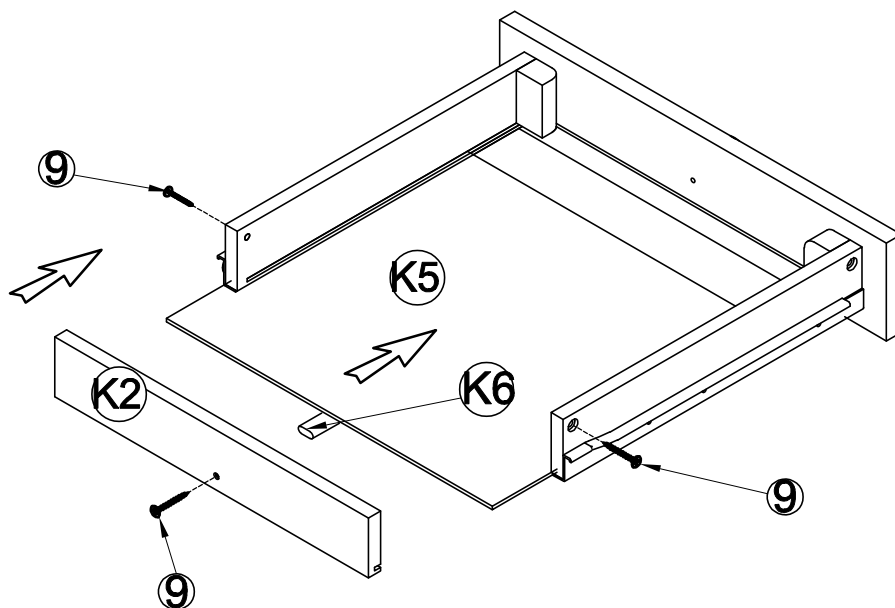

9



3(pcs)

**STEP 17:** Push 1 drawer into it position

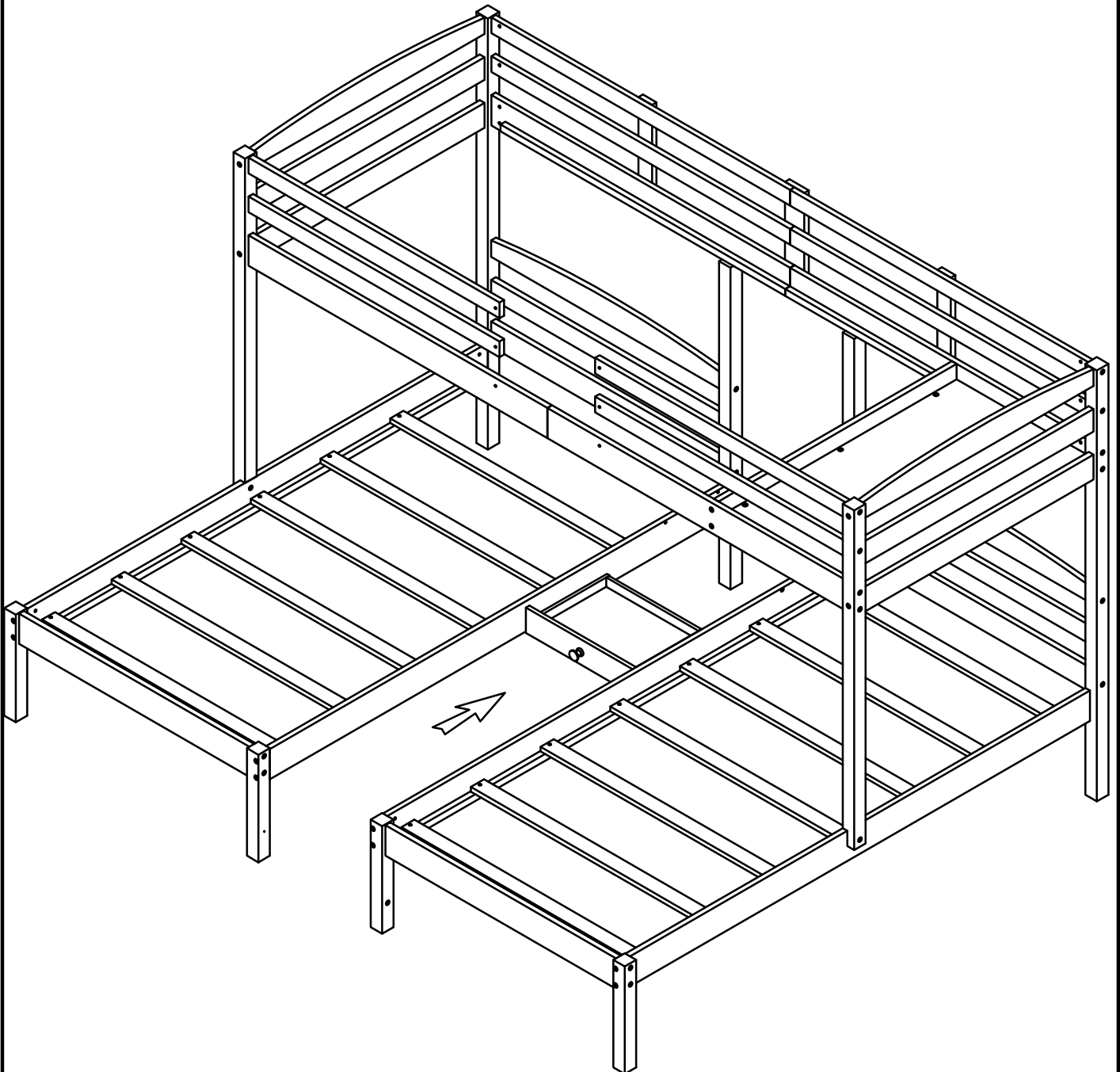

# STEP 18: Following below illustration

-Using hardware #2 to Assembly M1,M2,M4 Woodbar with Legs L1,L3

-Using hardware #2 to Assembly M1,M2,M3 Woodbar with Legs L2,L4

-Look at detail view for more detail

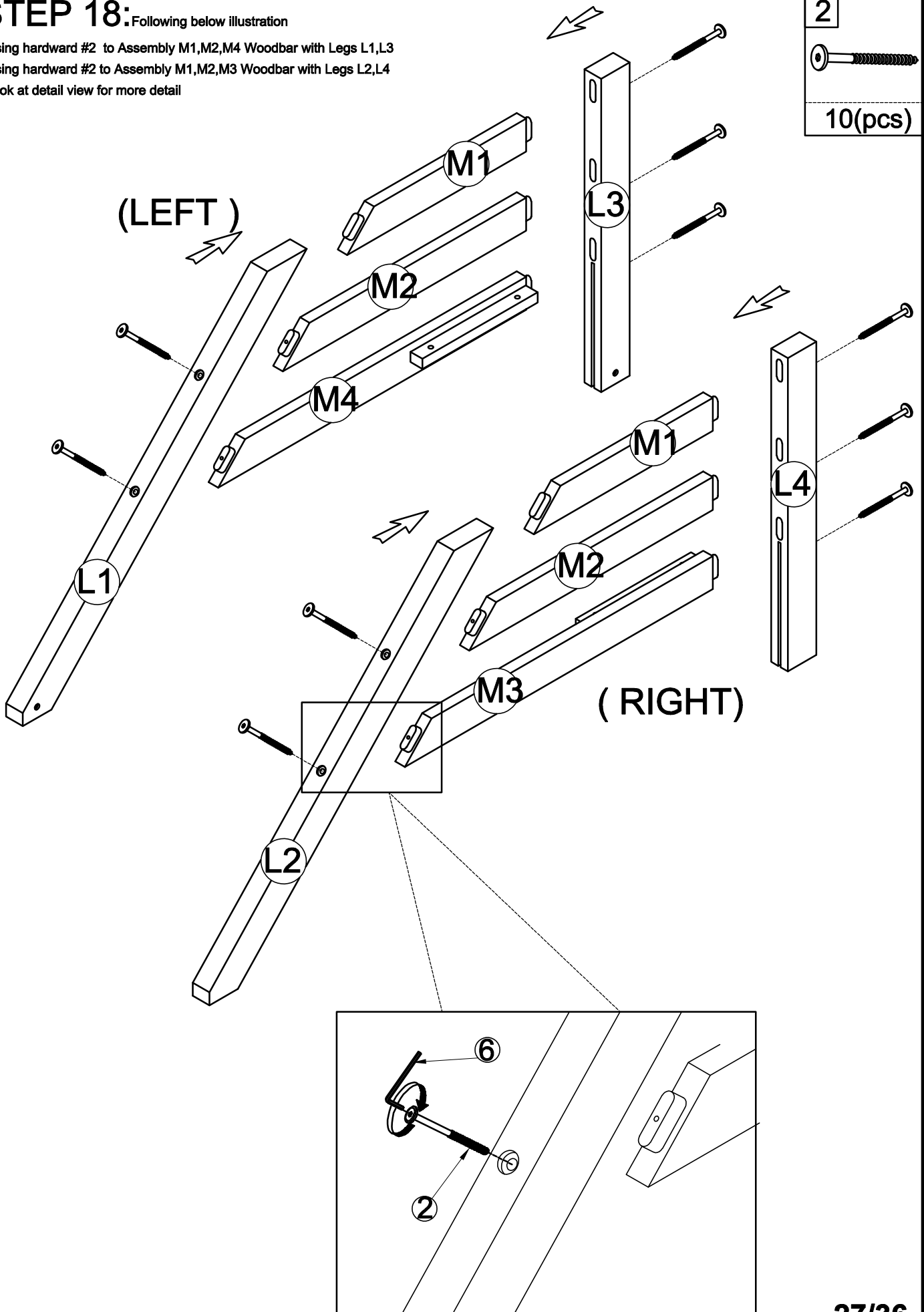

# STEP 19: Following below illustration

-Using hardware #2 to Assembly N4,M5,M8,M9,M11 Woodbar and N2,N3(x2) panels with Legs L7,L8

-Using hardware #2a to Assembly N4,M6,M7,M10,M11 Woodbar and N2,N3(x2) panels with Legs L5,L6

Look at detail view for more detail

2



16(pcs)

(LEFT)

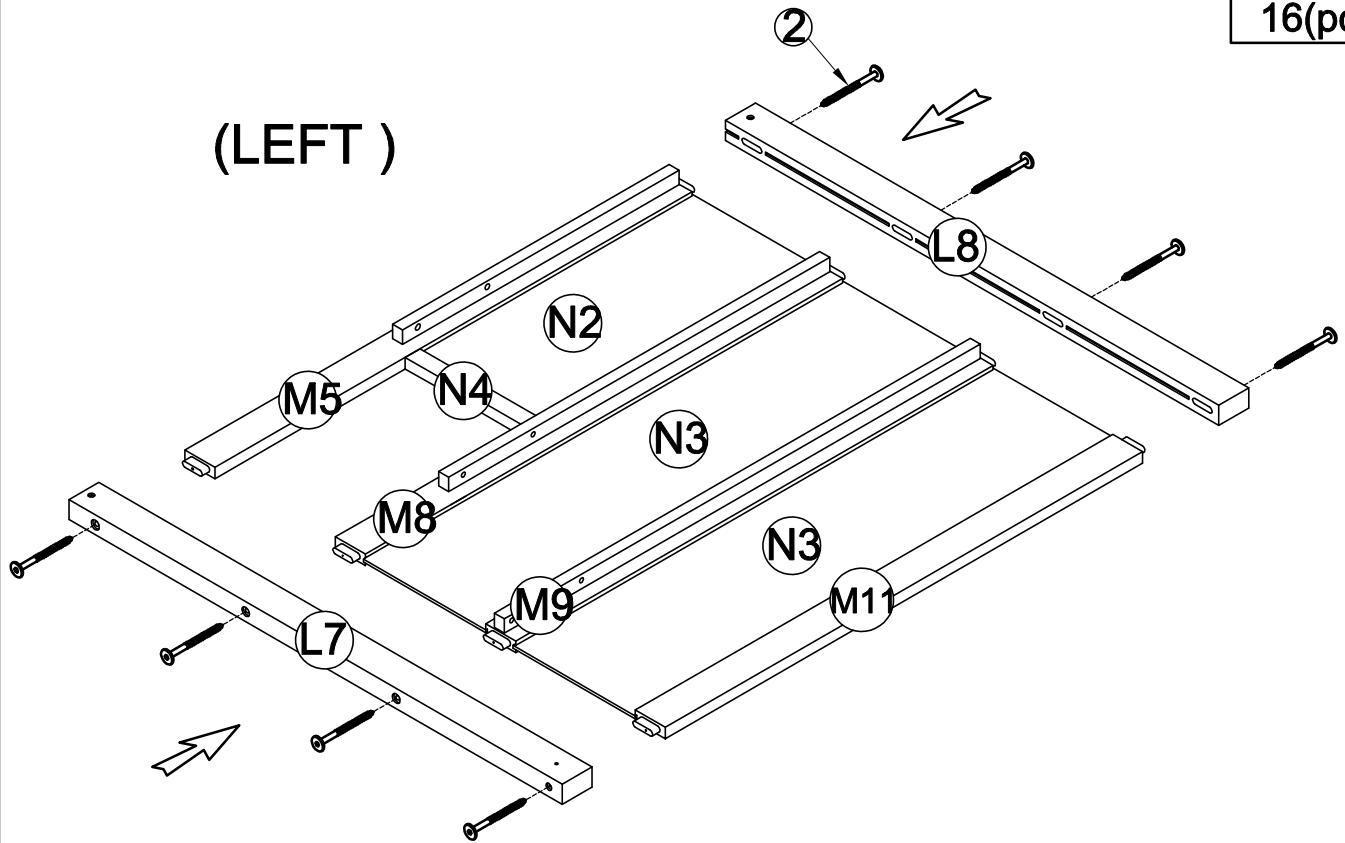

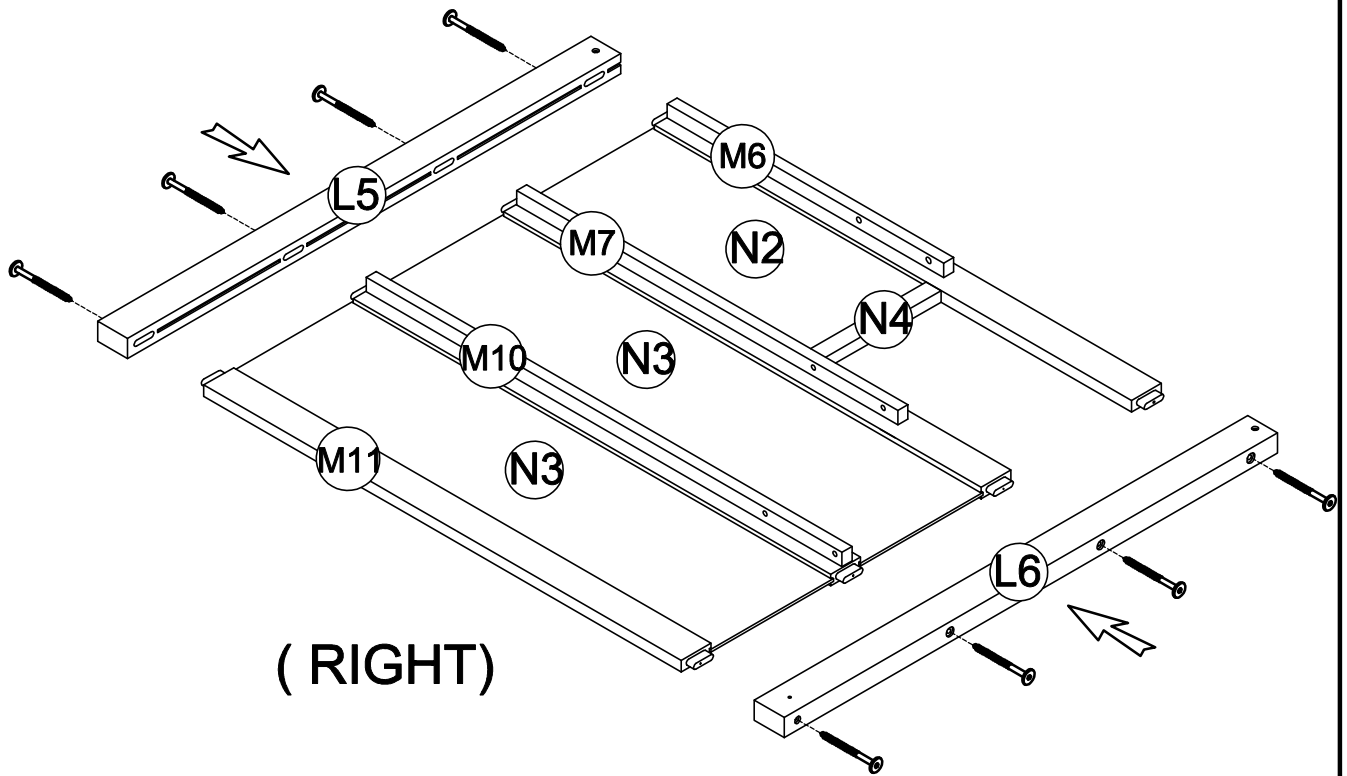

(RIGHT)



# STEP 20: Following below illustration

-Using hardware #9 and Dowel #18 to Assembly Frames(completed on step 18) and N4 woodbar,N1 Panel with Frame(completed on step 19)  
Look at detail view for more detail

18		9	
4 pcs		4x2 pcs	

( LEFT )

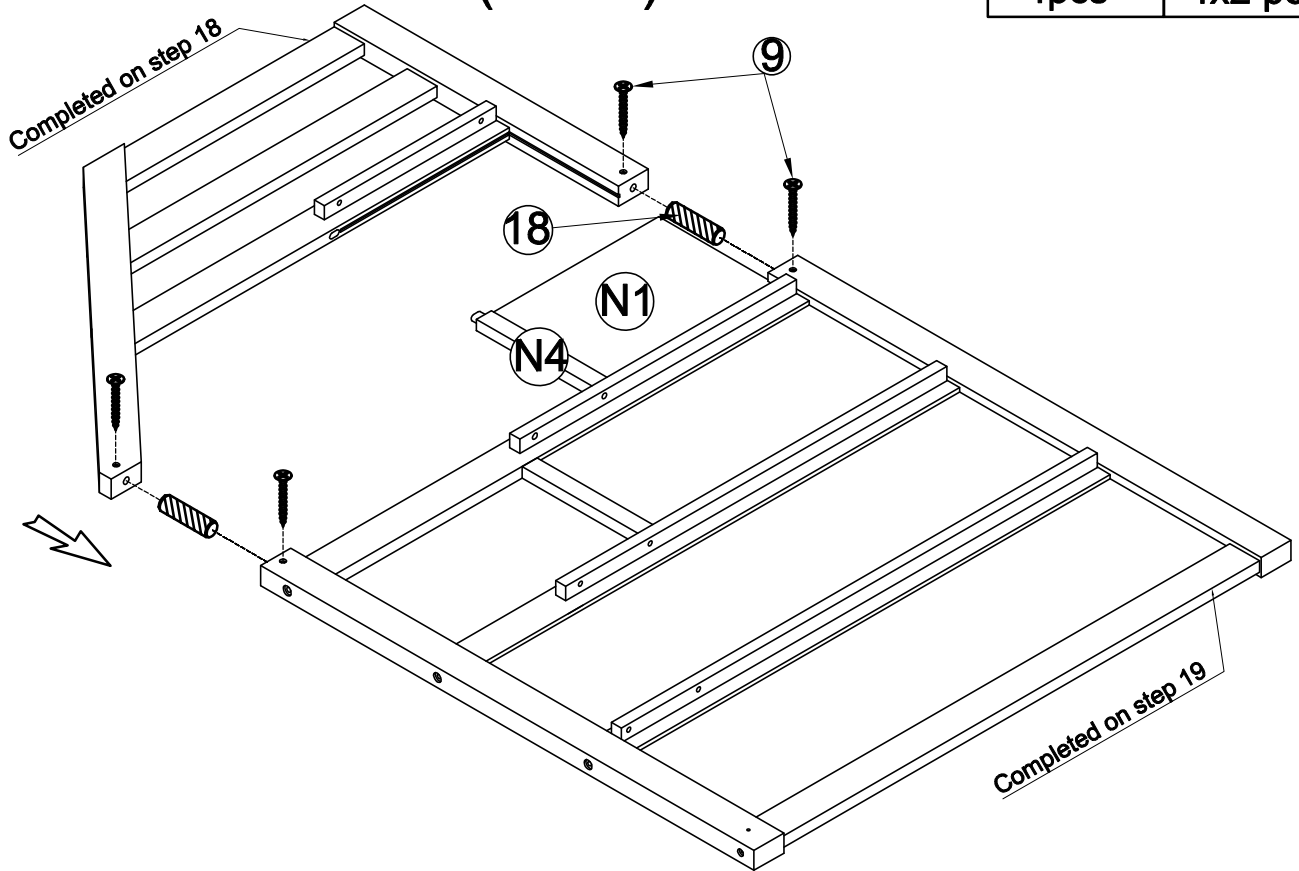

Completed on step 18

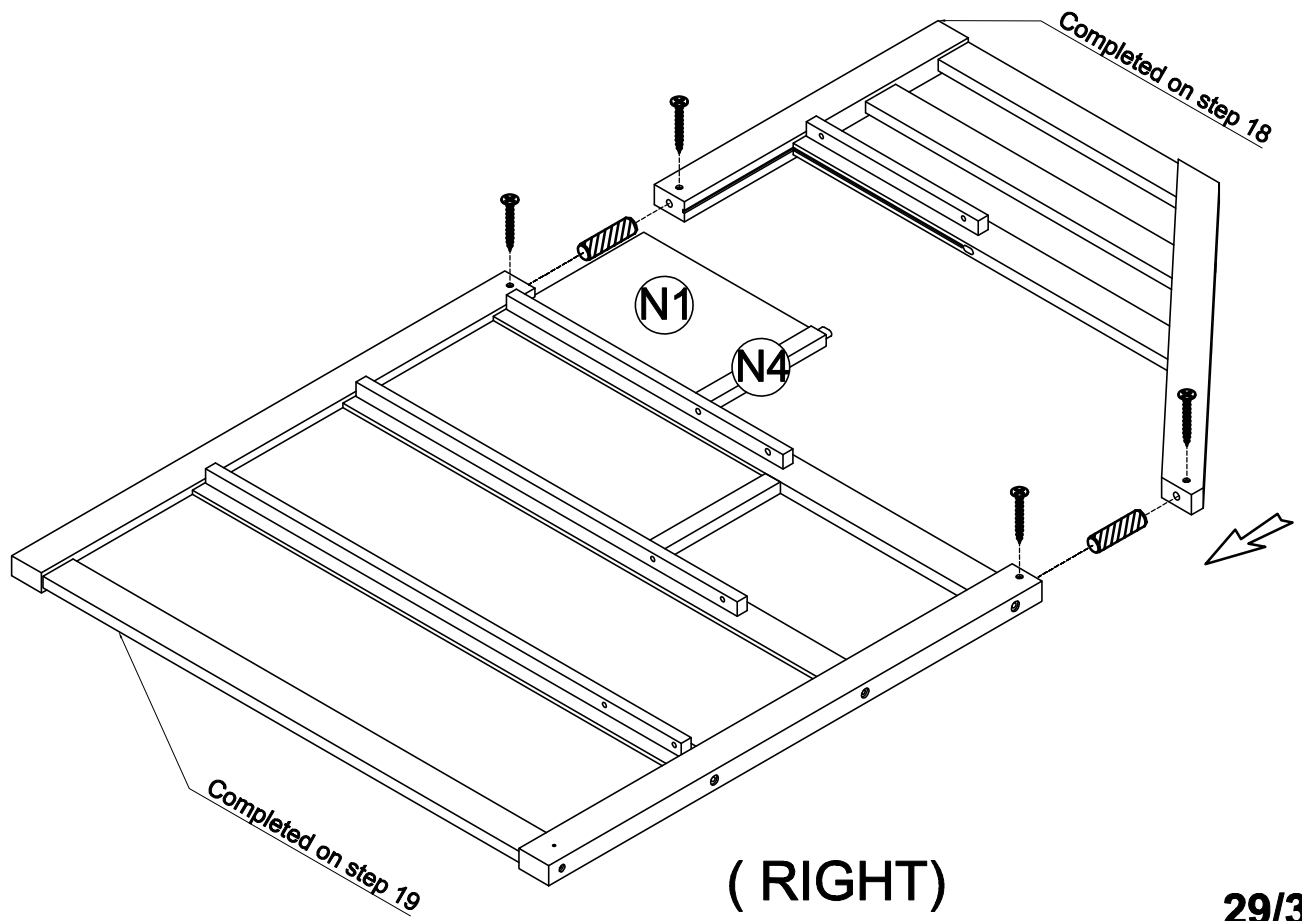

( RIGHT )

# STEP 21:

Following below illustration

- Using hardware #11 to Assembly Frames(completed on step 20)
- with P8 wood bar
- .Look at detail view for more detail

11



2(pcs)

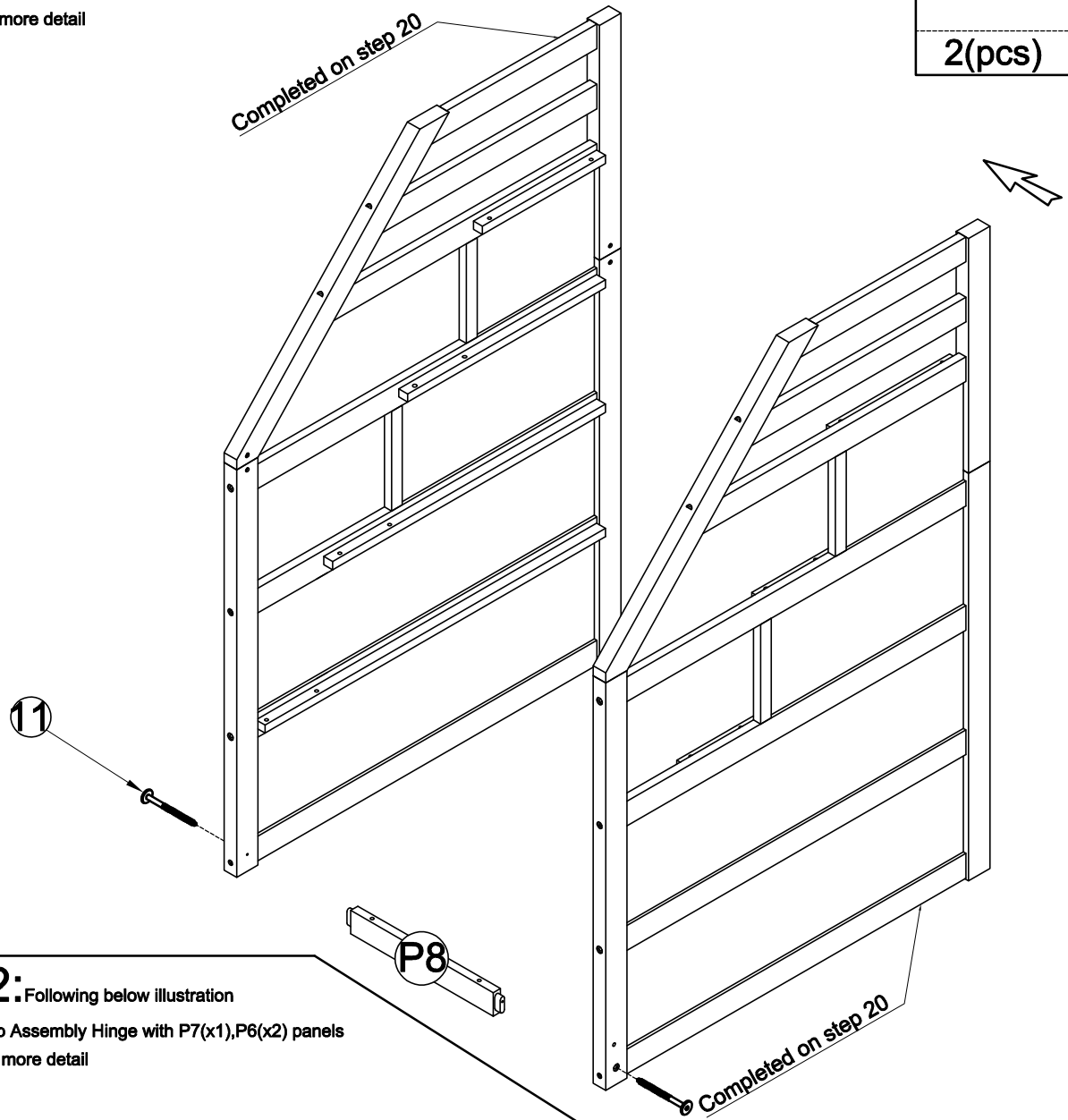

# STEP 22:

Following below illustration

- Using hardware #19 to Assembly Hinge with P7(x1),P6(x2) panels
- .Look at detail view for more detail

19



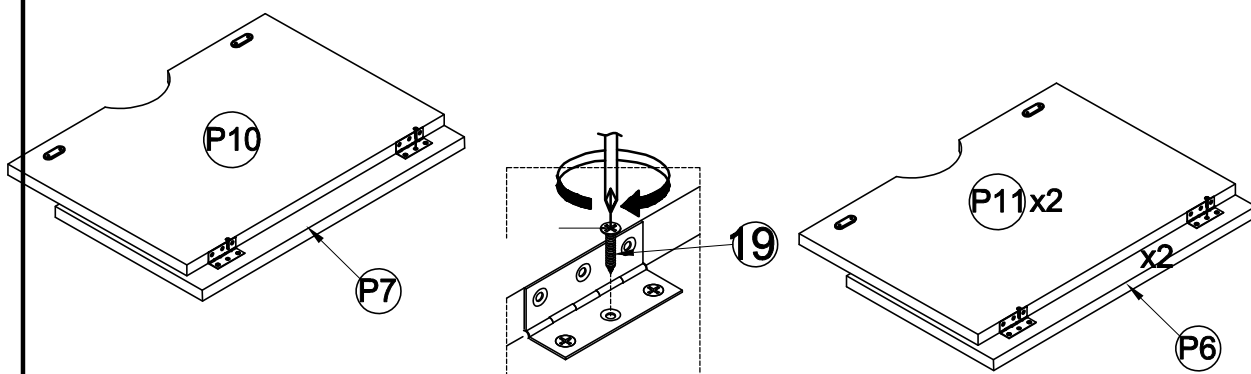

18(pcs)



# STEP 23: Following below illustration

Using hardware #12 and dowel #14 to Assembly Frames(completed on step 21) with L6 panel, L7 frame(completed on step 14).Look at detail view for more detail

12	14
	
4pcs	4pcs

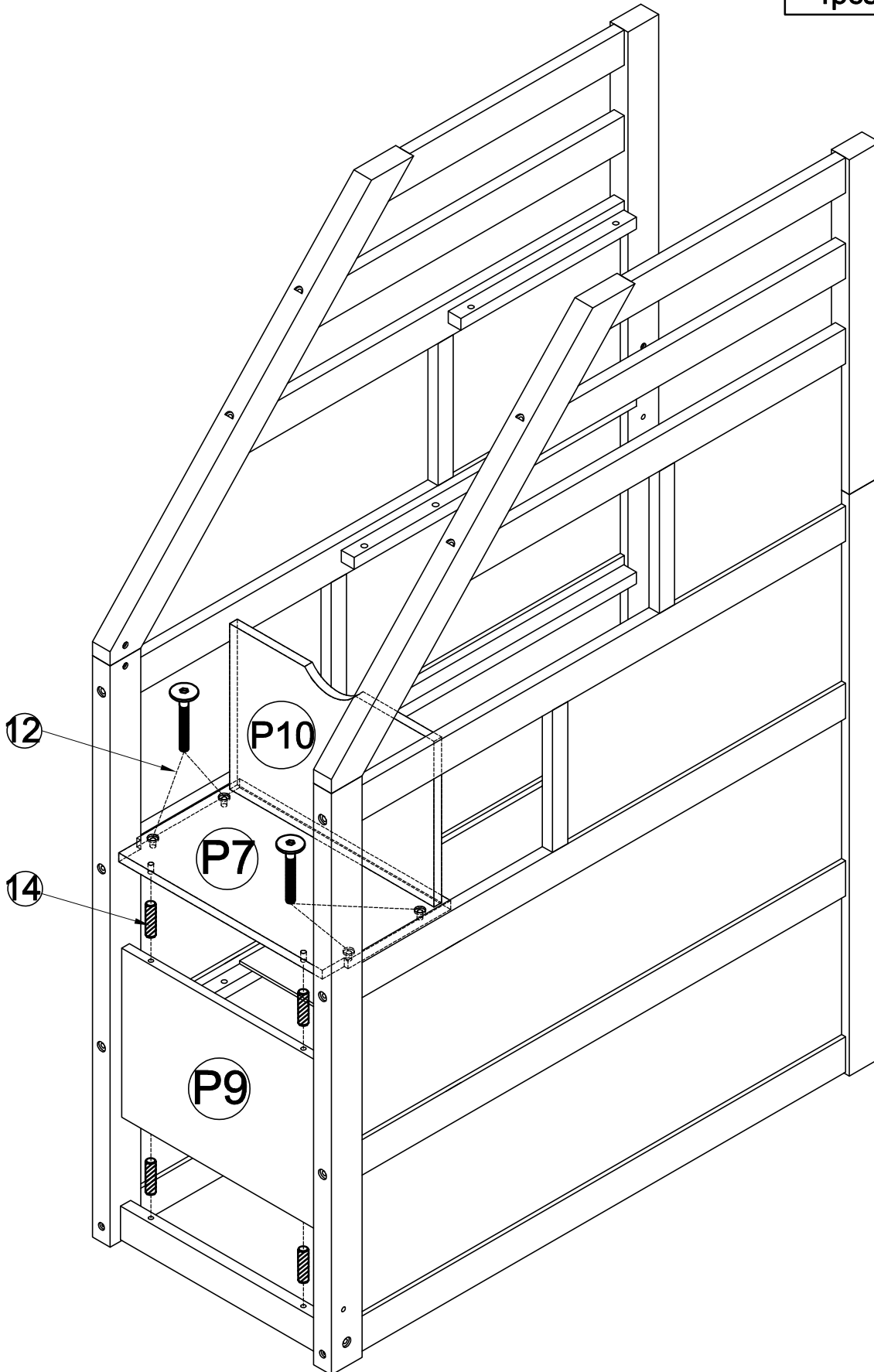

# STEP 24: Following below illustration

-Using hardward #12 to Assembly Frame(completed on step 23) with P2 panel,P6 Frames(completed on step 22)  
Look at detail view for more detail

12



12pcs

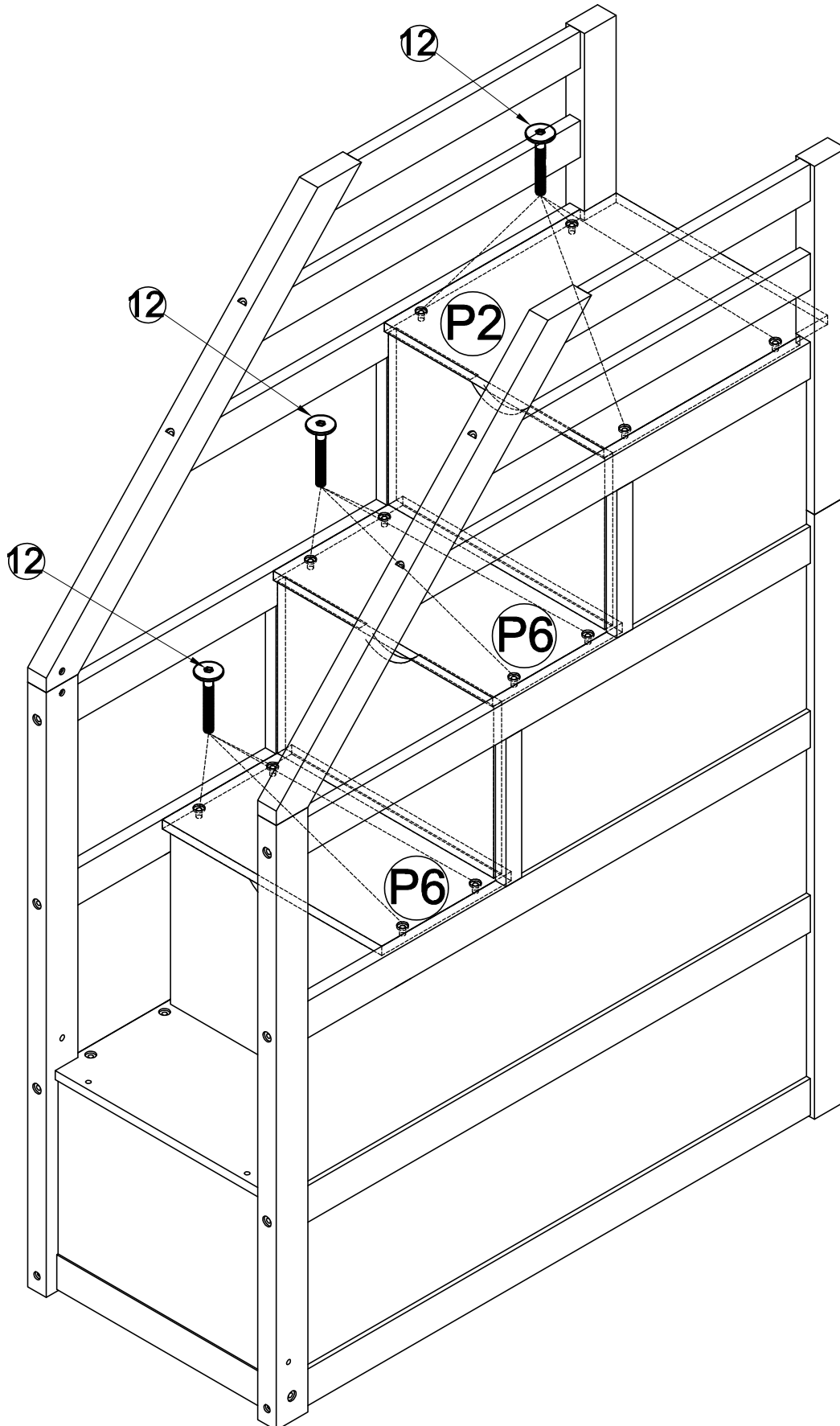

# STEP 25: Following below illustration

- Using hardware #15 to Assembly Frame(completed on step 24) with P3,P4,P5 panels
- Look at detail view for more detail

15	
14 pcs	

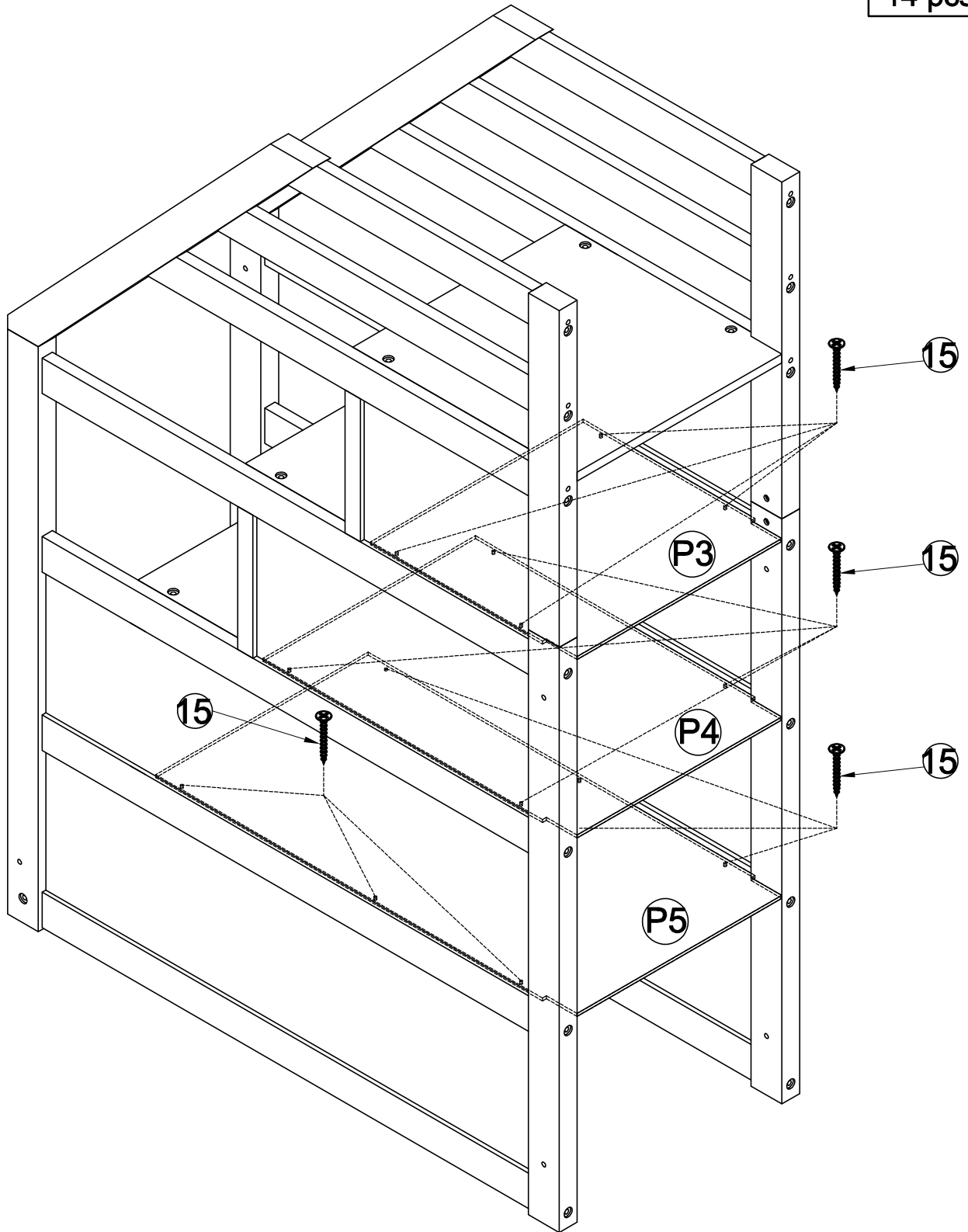

# STEP 26: Following below illustration

- Using hardward #20 to Assembly Frames(completed on step 25) with P1(x2) panels
- Look at detail view for more detail

20



12 pcs

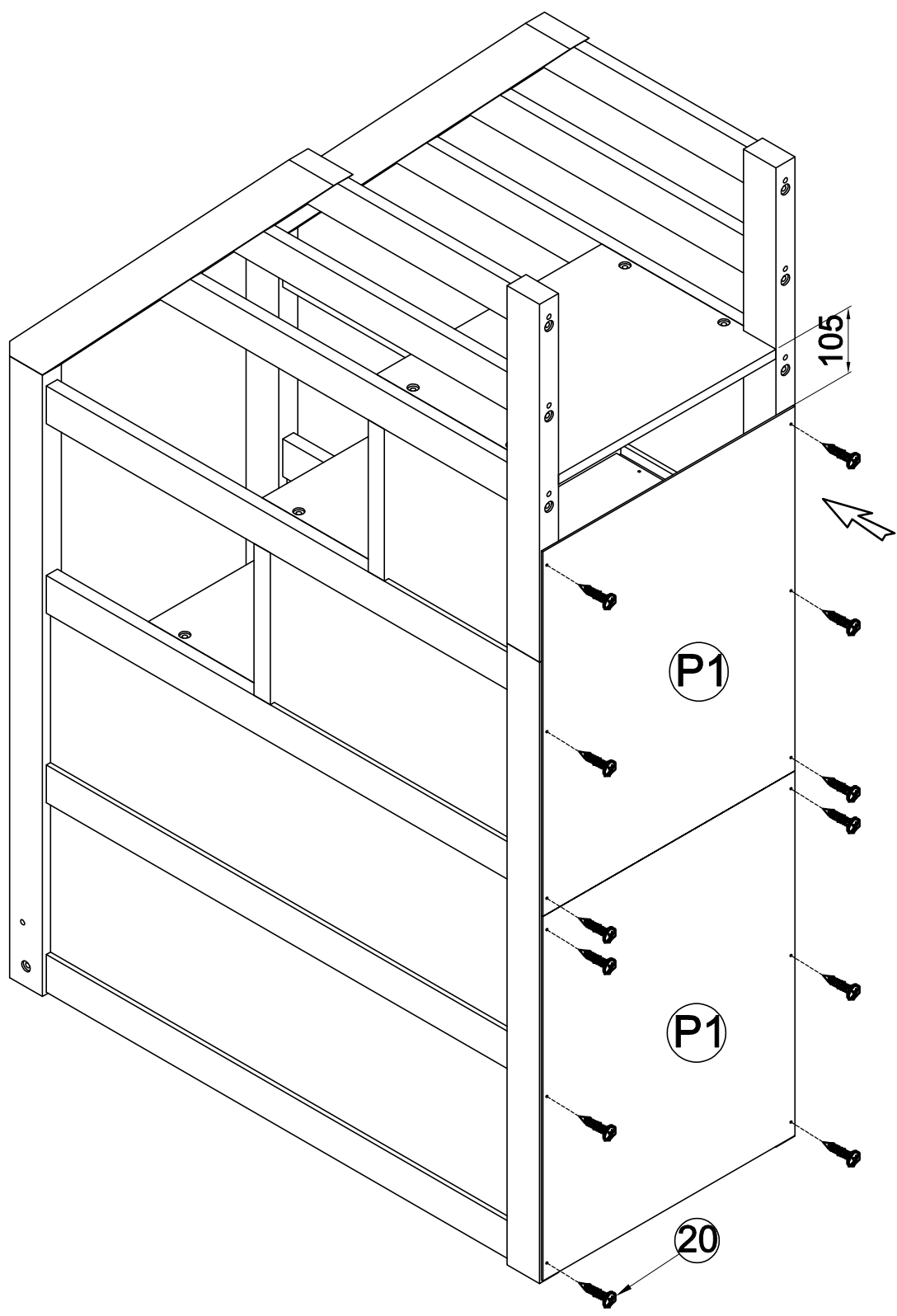

# STEP 27: Following below illustration

- Using hardware #7 to Assembly Frame(completed on step 17) with Frame(completed on step 26)
- Look at detail view for more detail

7



6(pcs)

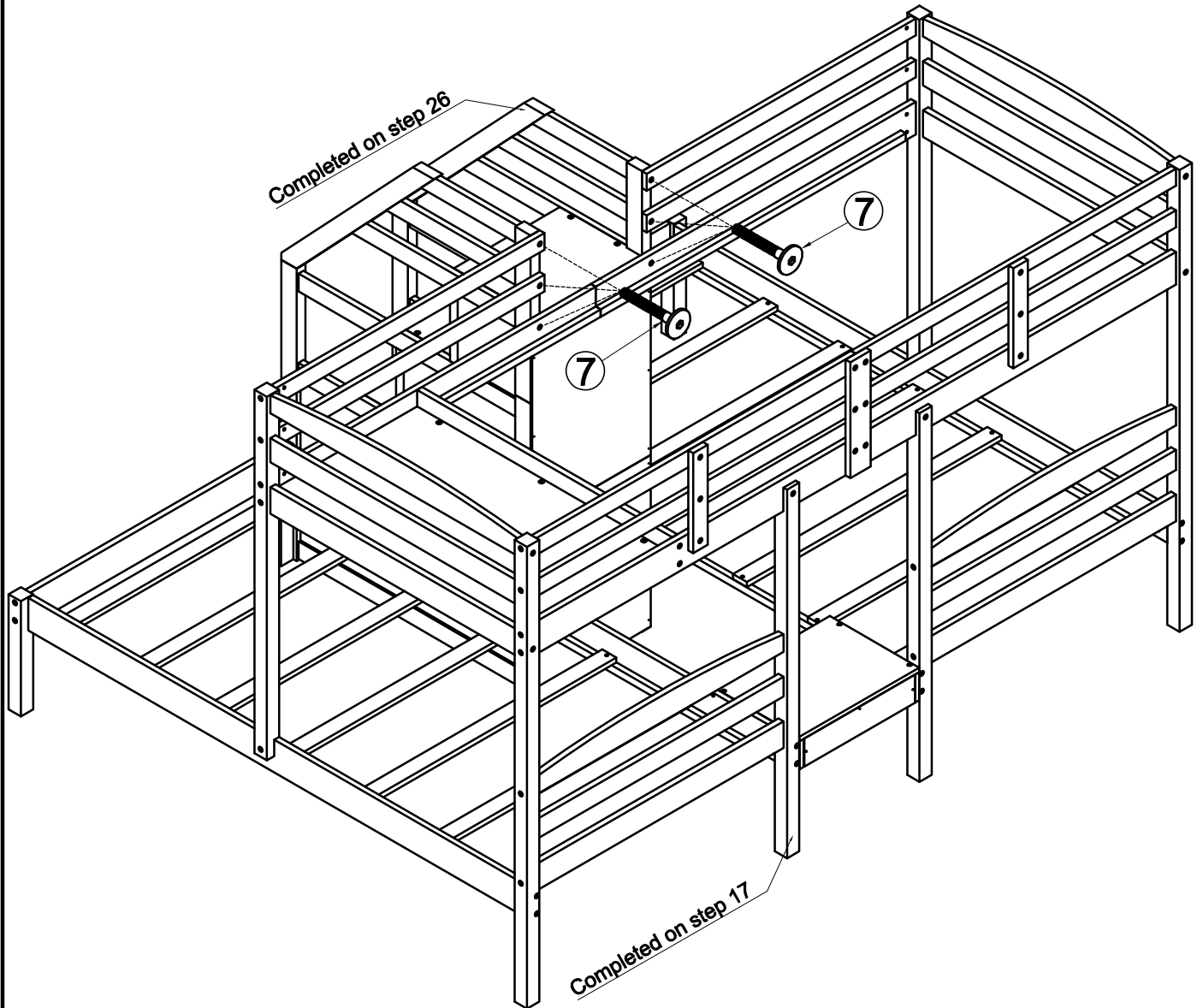

# STEP 28: Following below illustration

- Using hardware #13 to Assembly Stair With Bed
- Screw 14 slats E with Side Rail C5,C6,C7,C8 by using hardware #9.
- Look at detail view for more detail

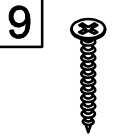
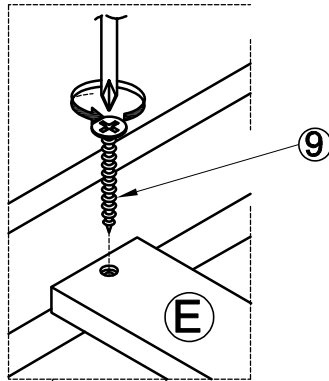

28(pcs)

13



2(pcs)

