

# ASSEMBLY INSTRUCTIONS

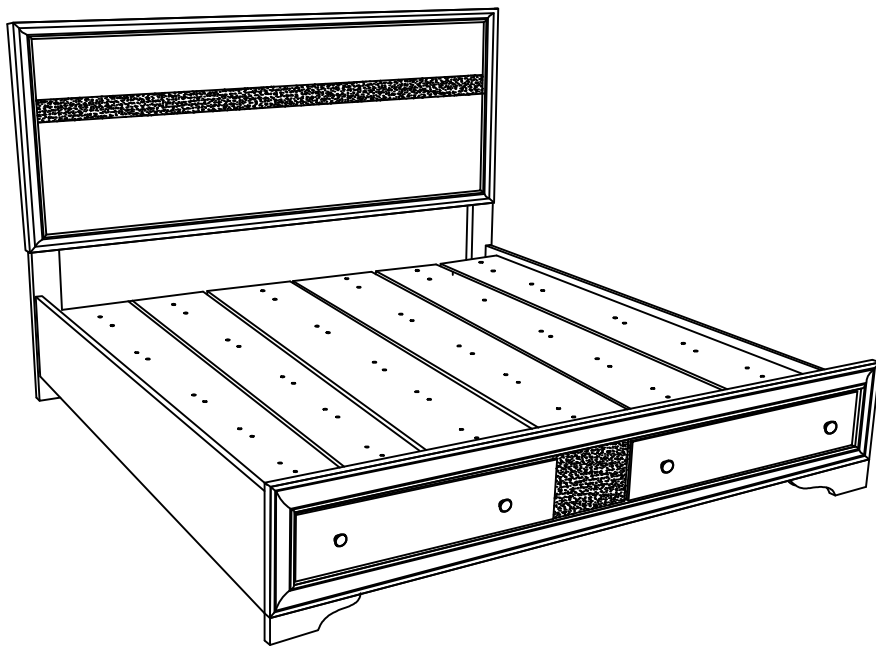

## TOOLS REQUIRED



Allen Wrench

(Included)



Phillips Screwdriver

(Not Included)



2 - People Recommended

## ASSEMBLY RATING



EASY → DIFFICULT

The Assembly Rating is a 5-point system showing the level of effort needed to assemble a specific product.



## **CHECK BEFORE STARTING**

### **Are you missing anything?**

Double-check all parts, hardware and accessories listed are all accounted for.

### **Check out our Quick Tips!**

We recommend reviewing the pre-assembly handouts. Even experts need a refresher now and then!

### **Should we send any replacements?**

Are there any irregularities or flaws in the parts? We can send replacements!

### **Prep Time!**

Please review the assembly instructions and all diagrams prior to assembling.

# PRE ASSEMBLY INTRODUCTION

We understand building ready-to-assemble furniture can be a challenging experience for some. To help avoid confusion, we have provided some helpful tips that may speed up the process.



## Teamwork

ALWAYS have at least two people to help with transporting and assembling the product to avoid potential injury and/or damage.



## Suitable Location

Assembling near the area of the intended location is highly recommended.



## Sufficient Space

Make sure you have enough space to move around during the assembly.



## Avoid Scratches

Use cardboard, blankets or a carpeted area while assembling furniture to prevent to prevent scratches and damages.

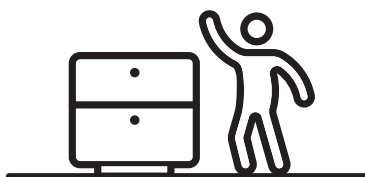
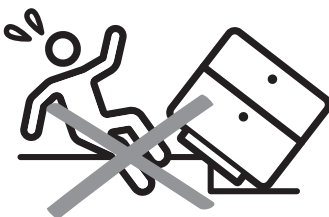

## Flat Surface

Make sure the furniture rests on a flat and level surface with each leg evenly touching the floor.

# ASSEMBLY AND CARE ADVICE



**FAILURE TO FOLLOW THE GUIDELINES BELOW MAY RESULT IN INJURY AND/OR PROPERTY DAMAGE.**



Position each part correctly and insert screws or bolts into their respective holes.



Use the appropriate hand tools or power tools for assembly. Select steps, such as tightening screws and/or bolts, may require hand tools to avoid causing damage during assembly.



Turn clockwise to tighten and only tighten when step is completed or when instructed to do so.



Save the instructions and store any supplied tools for later maintenance.



After two weeks, check and tighten any loose hardware and repeat again every six months thereafter.

**IT IS THE USER'S RESPONSIBILITY TO MAINTAIN THE FURNITURE. THE HARDWARE MAY LOOSEN OVER TIME AND MAY CAUSE THE FURNITURE TO BE WOBBLY AND UNABLE TO SUPPORT ITS INTENDED WEIGHT CAPACITY. THIS MAY LEAD TO COLLAPSE AND MAY CAUSE SERIOUS INJURY.**

# EASTERN KING BED



- Please keep instructions for future reference.
- Check the quantity and irregularity of parts and hardware before you start.

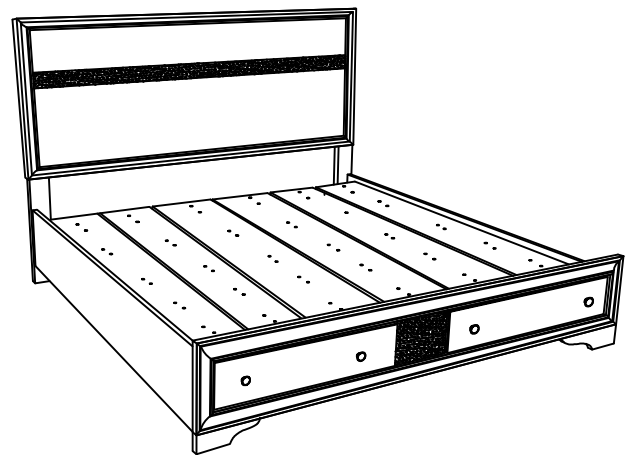

## PARTS

### Parts List (Box 1) Headboard Box

#1 1pc



Headboard

#2 1pc

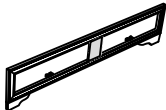

Footboard

#3 2pcs

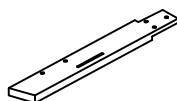

Headboard  
Leg L&R

### Parts List (Box 2) Side Rail Box

#4 2pcs

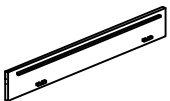

Side Rail

#5 1pc

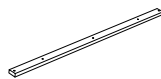

Center slat Drawer

#6 3pcs

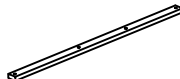

Bed Slat w/o marking  
1951 x 45 x 18mm

#7 2pcs



Bed Slat with marking  
1951 x 45 x 18mm

#8 8pcs



Bed Slat Support  
320 x 30 x 30mm

#9 1pc



Drawer Slat Support  
95 x 30 x 30mm

#10 2pcs



Drawer Support Rail  
633 x 40 x 20mm

#11 6pcs



Concealed Panel  
2040 x 295 x 9mm

### Parts List (Box 3) Drawer Box

#12 2pcs

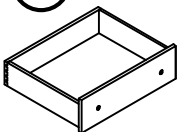

Footboard Drawer

## HARDWARE

### Parts List (Box 1) Headboard Box

#A 6pcs

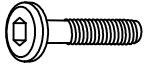

Bolt 1/4" x 1-2/8"

#B 6pcs



Lock Washer

#C 6pcs



Flat Washer

#D 1pc

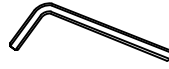

Allen Key M4

### Parts List (Box 2) Side Rail Box

#E 2pcs

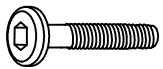

Bolt 1/4" x 1-3/8"

#F 9pcs

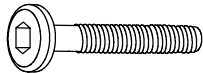

Bolt 1/4" x 2"

#G 2pcs



Lock Washer

#H 2pcs



Flat Washer

#I 1pc

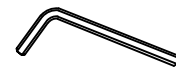

Allen Key M4

#J 1pc

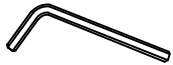

Allen Key M5

#K 14pcs

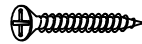









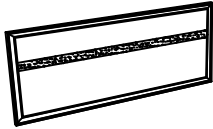



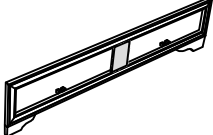
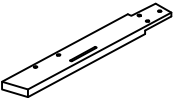

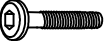





CSK m4 x 32mm

#L 30pcs

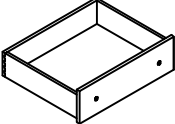

P.H Screw m3.5x20mm

Carton	Designation	Part		Hardware
	<b>E.King Size Bed HB, FB &amp; HB Legs</b>	#1	 X 1	 #A x 6pcs  #B x 6pcs  #C x 6pcs  #D x 1pc
#2		 X 1		
#3		 X 2		
	<b>E.King Size Bed Rails</b>	#4	 X 2	 #E x 2pcs  #F x 9pcs  #G x 2pcs  #H x 2pcs  #I x 1pc  #J x 1pc  #K x 14pcs  #L x 30pcs
#5		 X 1		
#6		 X 3		
#7		 X 2		
#8		 X 8		
		 X 1		
		 X 2		
		 X 6		
	<b>E.King Size Drawer</b>		 X 2	

# ASSEMBLY INSTRUCTIONS

Prepare 6 bolts assembly by inserting lock washer (#B), then flat washer (#C) onto bolts (#A).  
Align HB legs (#3R/L) to the holes of the headboard (#1). Secure by using bolts (#A).

## 1

- Part #1 x1pc
- Part #3 x2pcs
- Hardware #A x6pcs
- Hardware #B x6pcs
- Hardware #C x6pcs

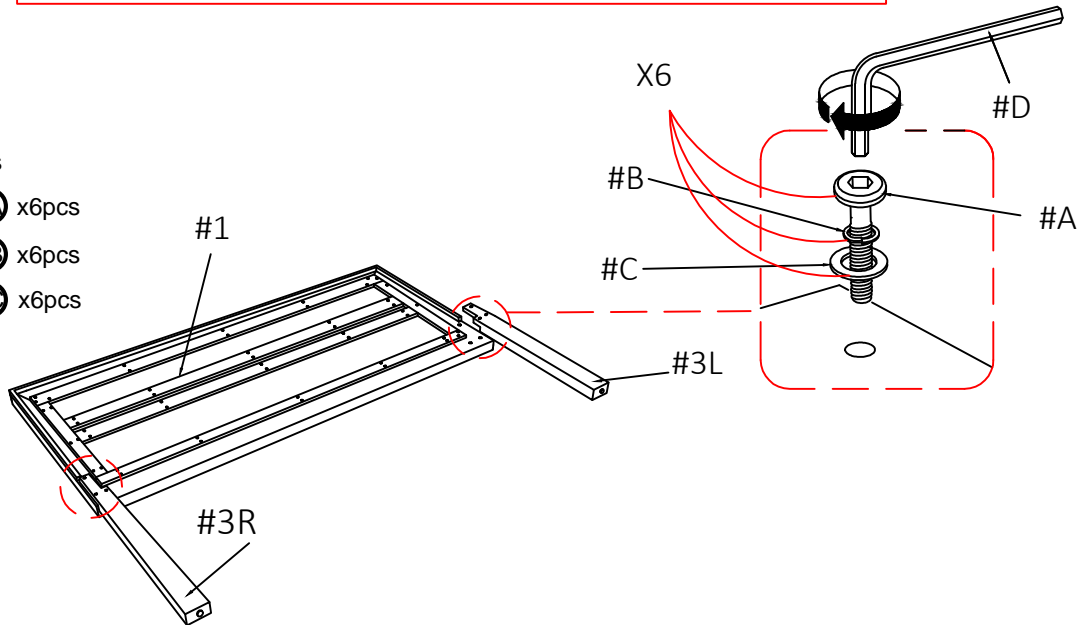

## 2

- Part #2 x1pc
- Part #4 x2pcs

1) Loosen the bolts attached to headboard (#1) and footboard (#2), then hook the side rails (#4) to the loosened bolts on the headboard (#1) and footboard (#2).  
2) Tighten the bolts on the headboard (#1) and footboard (#2) to the side rail hooks (#4).

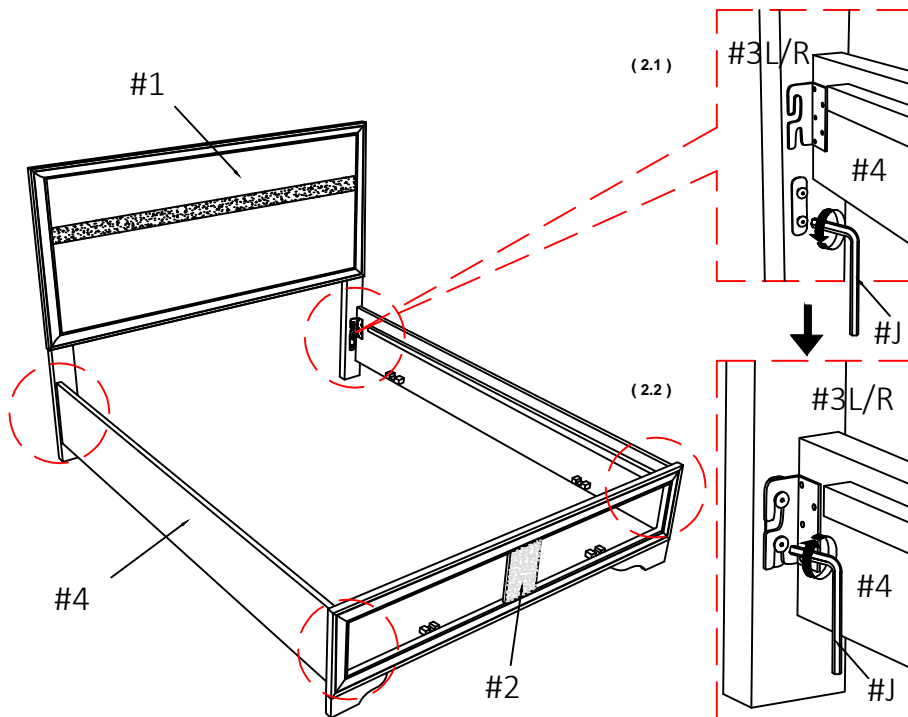

# ASSEMBLY INSTRUCTIONS

## 3

Part #5 x1pc  
Hardware #K x2pcs

Align center slat drawer (#5) to the side rails (#4), then secure by using screws (#K).

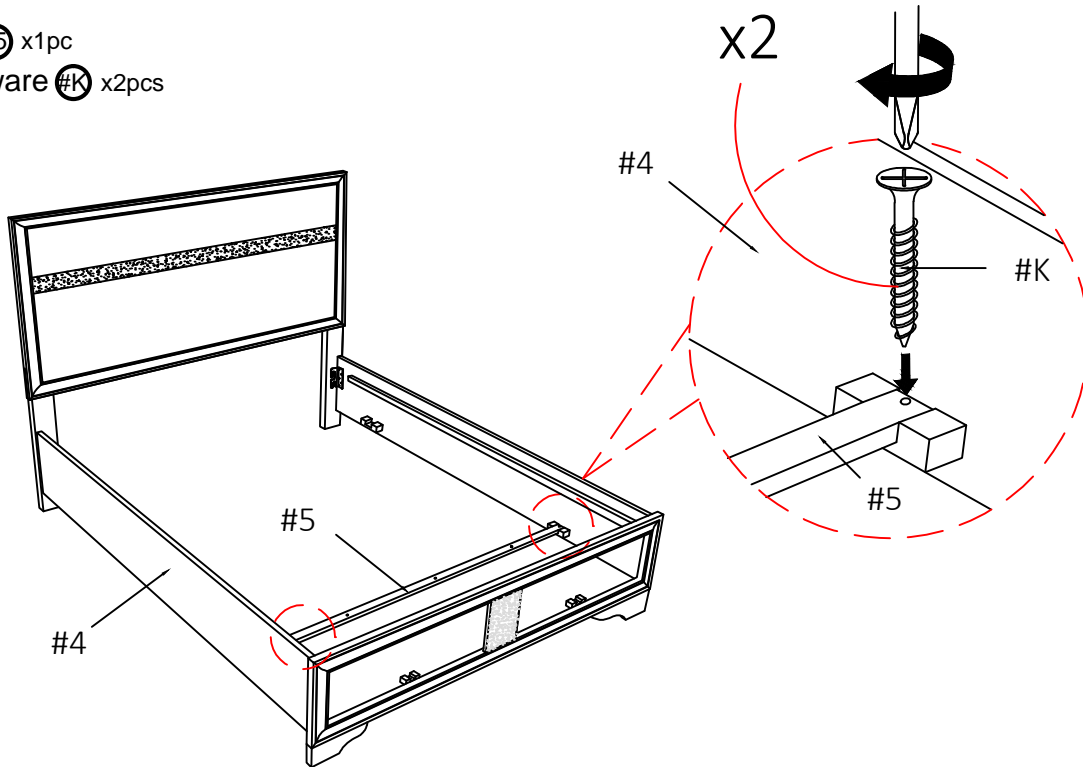

## 4

Part #9 x1pc  
Hardware #F x1pc

Align support leg (#9) to the hole of the center slat drawer (#5), then adjust leveler of the support leg (#9) according to ground level.

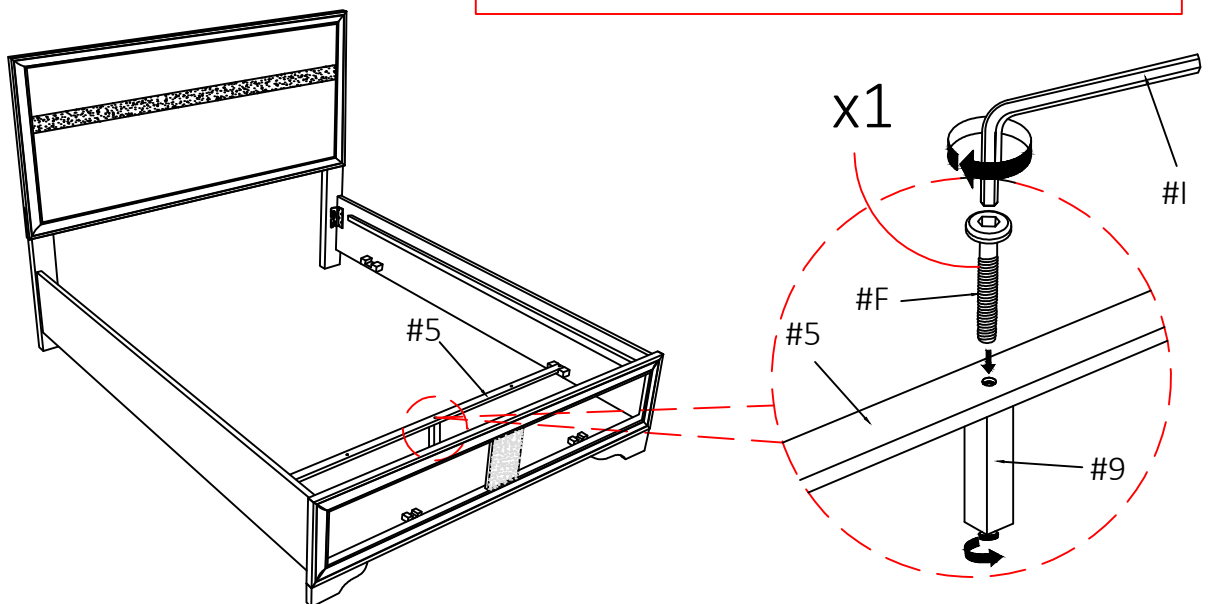

# ASSEMBLY INSTRUCTIONS

## 5

- Part #10 x1pc
- Hardware #E x2pcs
- Hardware #G x2pcs
- Hardware #H x2pcs
- Hardware #K x2pcs

Prepare 2 bolts assembly by inserting lock washer (#G), then flat washer (#H) onto bolts(#E). Align drawer support rail (#10) to the holes of the footboard (#2) and center slat (#5). Secure drawer rail (#10) to center slat (#5) by using bolts (#E), then secure drawer rail (#10) to footboard (#2) by using screws (#K).

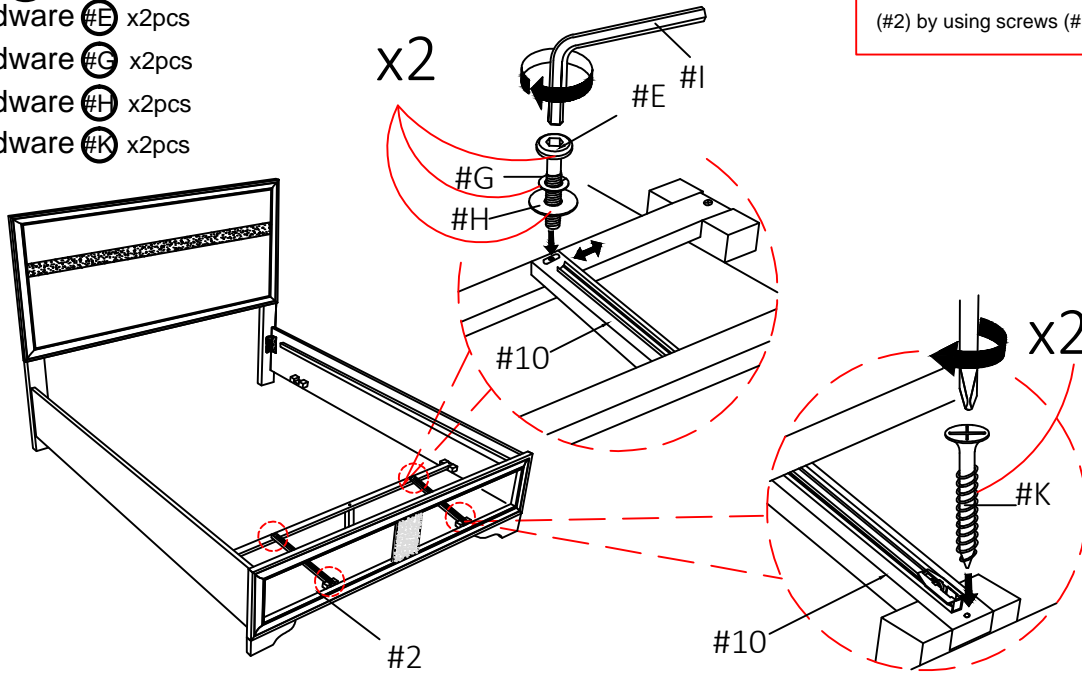

## 6

- Part #12 x2pcs

Unscrew knobs to the inside, then secure knobs to the outside of the drawers (#12).

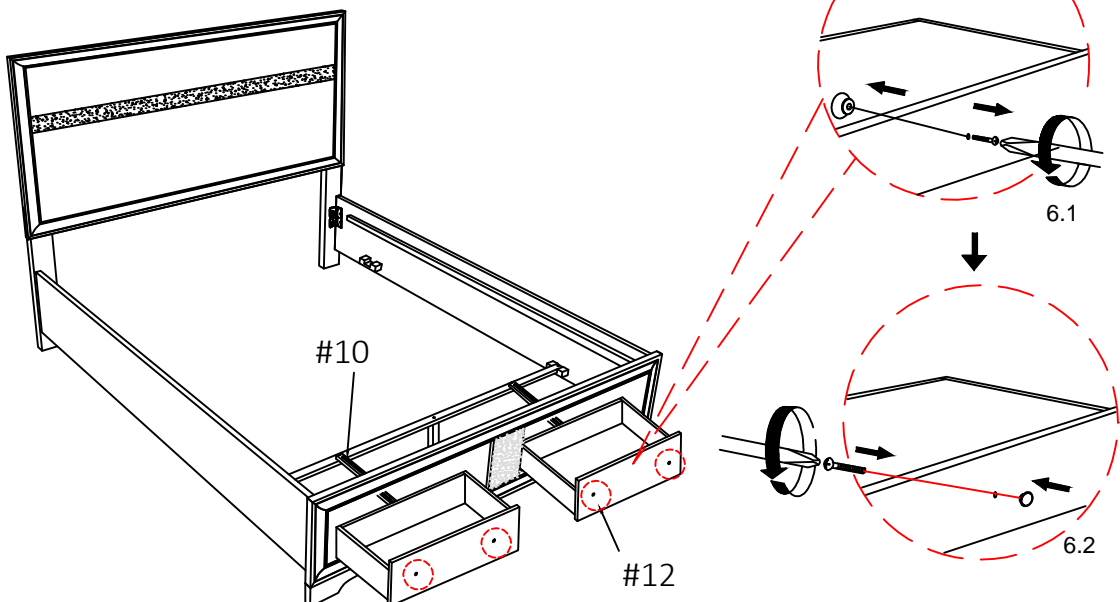

# ASSEMBLY INSTRUCTIONS

## 7

- Part #6 x3pcs
- Part #7 x2pcs
- Hardware #F x2pcs

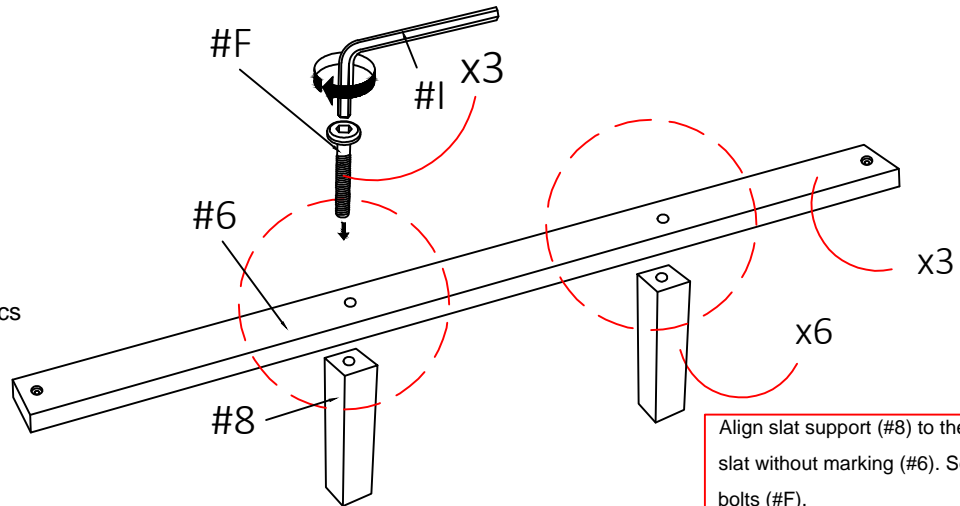

Align slat support (#8) to the hole of the bed slat with marking (#7). Secure by using bolts (#F).

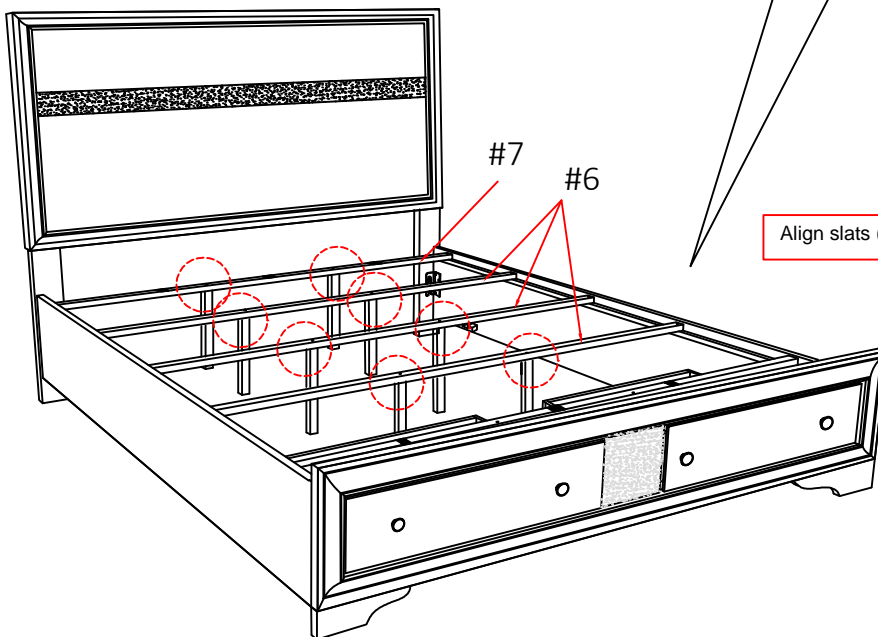
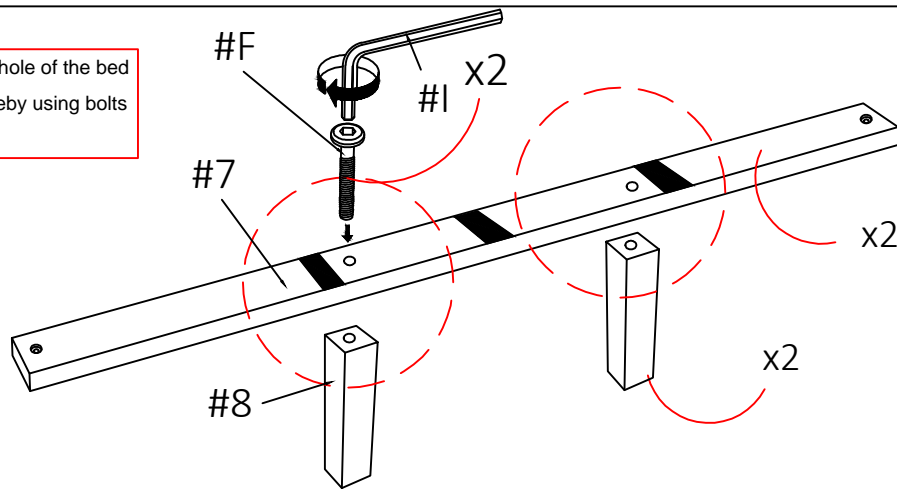

# ASSEMBLY INSTRUCTIONS

## 8

Hardware **#K** x10pcs

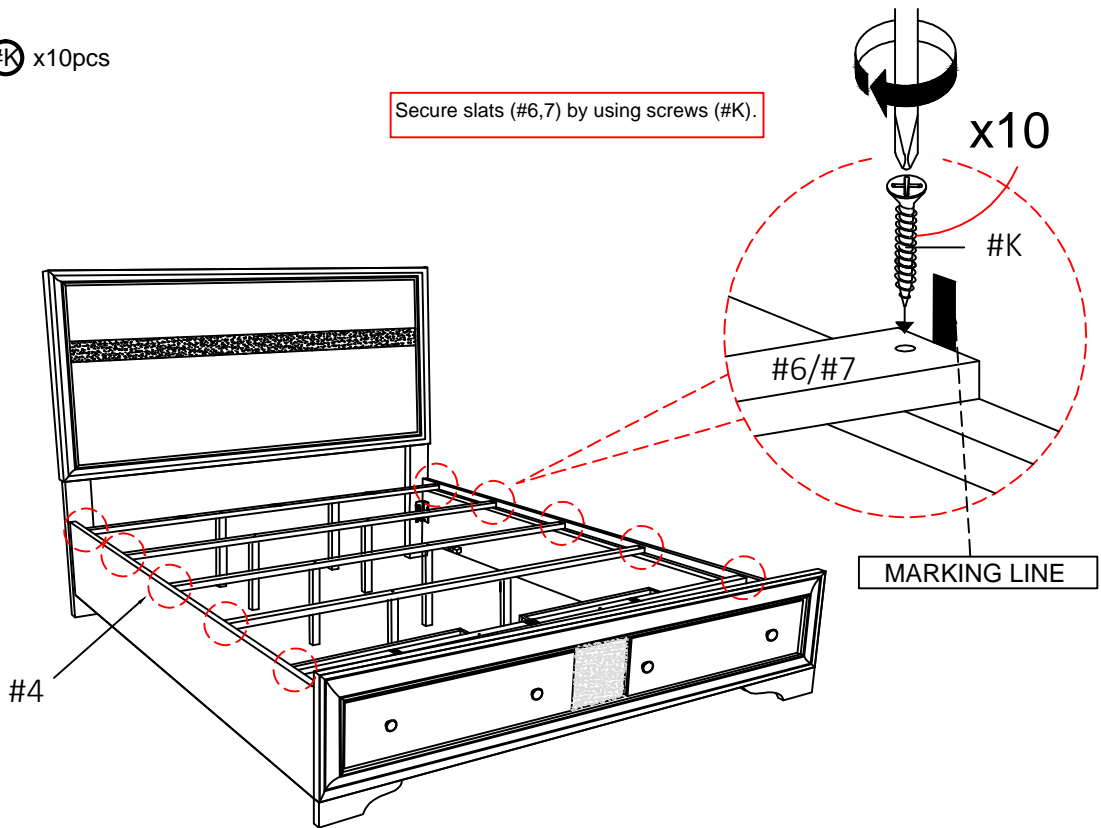

## 9

Part **#11** x5pcs  
Hardware **#L** x25pcs

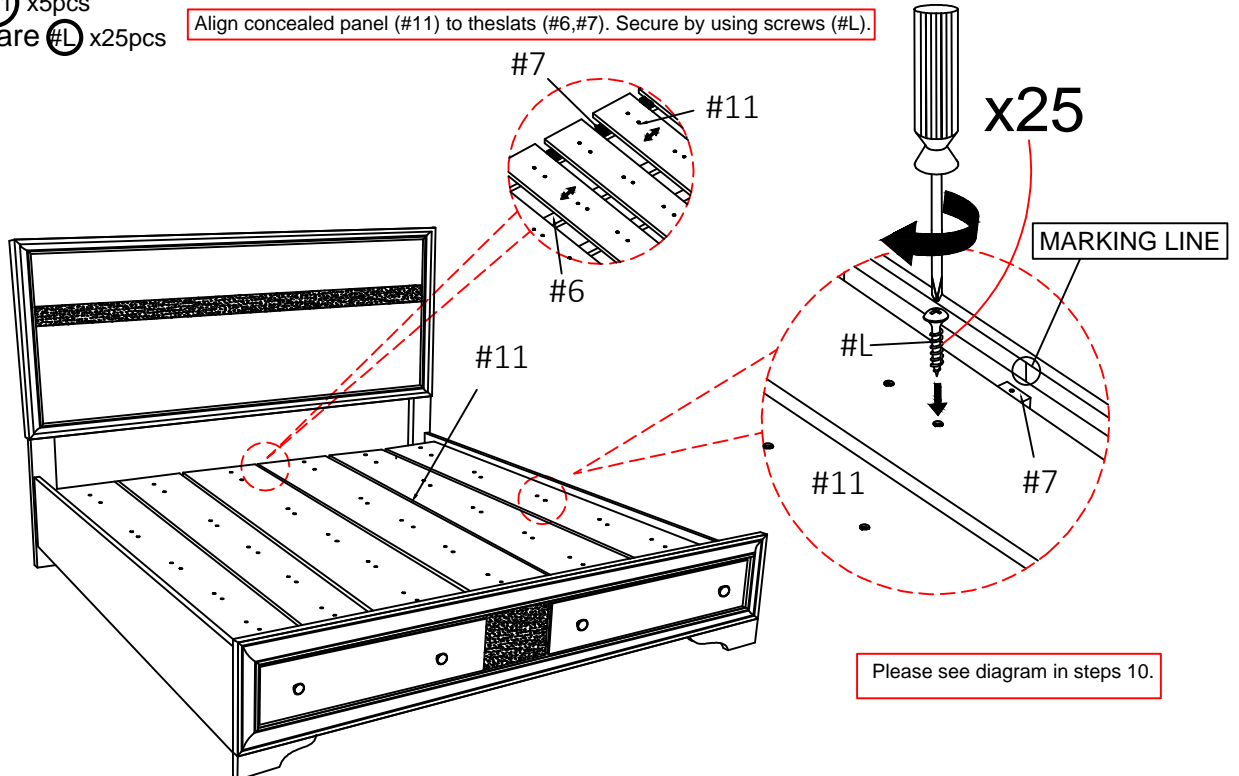

# ASSEMBLY INSTRUCTIONS

## 10

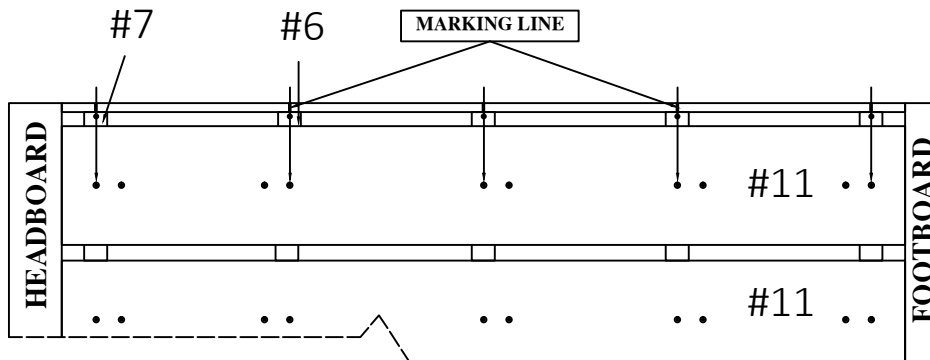

## 11

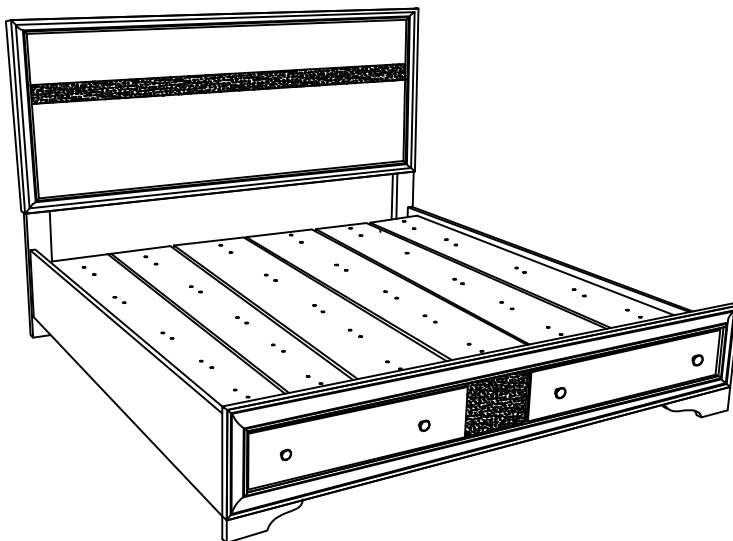

### ASSEMBLY COMPLETED



Please ensure the furniture rests on an even and flat surface. If the product wobbles or feels loose, double-check all bolts and/or screws are properly tightened and secured.



#### Keep this handy!

Please retain this instruction manual and any order-related information for future reference.



#### Lift, don't drag!

To avoid damage to product please always LIFT the product when transporting or adjusting the placement.