

ASSEMBLY INSTRUCTIONS

ITEM NO :
DRESSER

BOX OF DRESSER

ITEM	DRAWING	DESCRIPTION	QTY
A		DRESSER	1
B		LEFT FRONT LEG (Packed inside drawer)	1
C		RIGHT FRONT LEG (Packed inside drawer)	1
D		LEFT BACK LEG (Packed inside drawer)	1
E		RIGHT BACK LEG (Packed inside drawer)	1
F		SUPPORT LEG	1
G		TIPPING RESTRAINT (Affix to wall behind dresser) *Located in the Right Side Front Drawer	1

HARDWARE LIST

ITEM	DRAWING	DESCRIPTION	QTY
1		JCBC BOLT WITH SPRING WASHER AND FLAT WASHER (M6 x 40mm)	8
2		ALLEN KEY (M4)	1

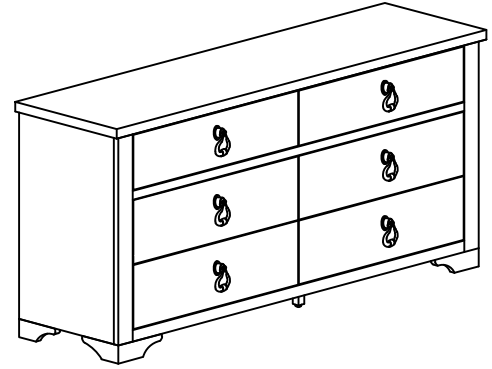

COMPLETED DRESSER ASSEMBLY

Wall

AFFIX TO WALL
BEHIND DRESSER

G

LEGS (PACKED
INSIDE DRAWER)

PART INSIDE

STEP 2

STEP 1

F

Level Me on
Uneven Floor

THE HARDWARE IS LOCATED IN THE PACKING ITEMS
THE ANTI TIPPING HARDWARE IS LOCATED IN THE RIGHT SIDE FRONT DRAWER OF DRESSER

NOTE : MUST TIGHTEN SCREWS PERIODICALLY. WITH USE SCREWS MAY BECOME LOOSE.
CHECK TIGHTNESS OF ALL SCREWS EVERY 6-8 WEEKS.

CLEANING INSTRUCTION



After assembled, clean & polish the completed parts if necessary with soft cloth and industrial recognized furniture polish

MADE IN MALAYSIA

ASSEMBLY INSTRUCTIONS

ITEM NO :
MIRROR

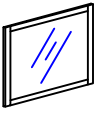
BOX OF MIRROR

ITEM	DRAWING	DESCRIPTION	QTY
A		MIRROR	1
B		MIRROR SUPPORT RAIL	2

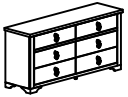

BOX OF DRESSER

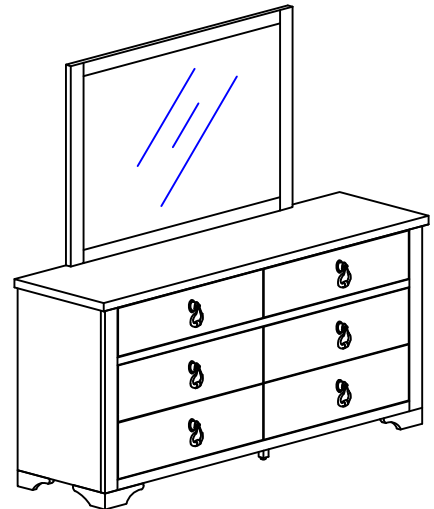
ITEM	DRAWING	DESCRIPTION	QTY
A		DRESSER	1



BOX OF MIRROR

HARDWARE LIST

ITEM	DRAWING	DESCRIPTION	QTY
1		JCBC BOLT WITH SPRING WASHER AND FLAT WASHER (M6 x 35mm)	8
2		ALLEN KEY (M4)	8

COMPLETED MIRROR ASSEMBLY

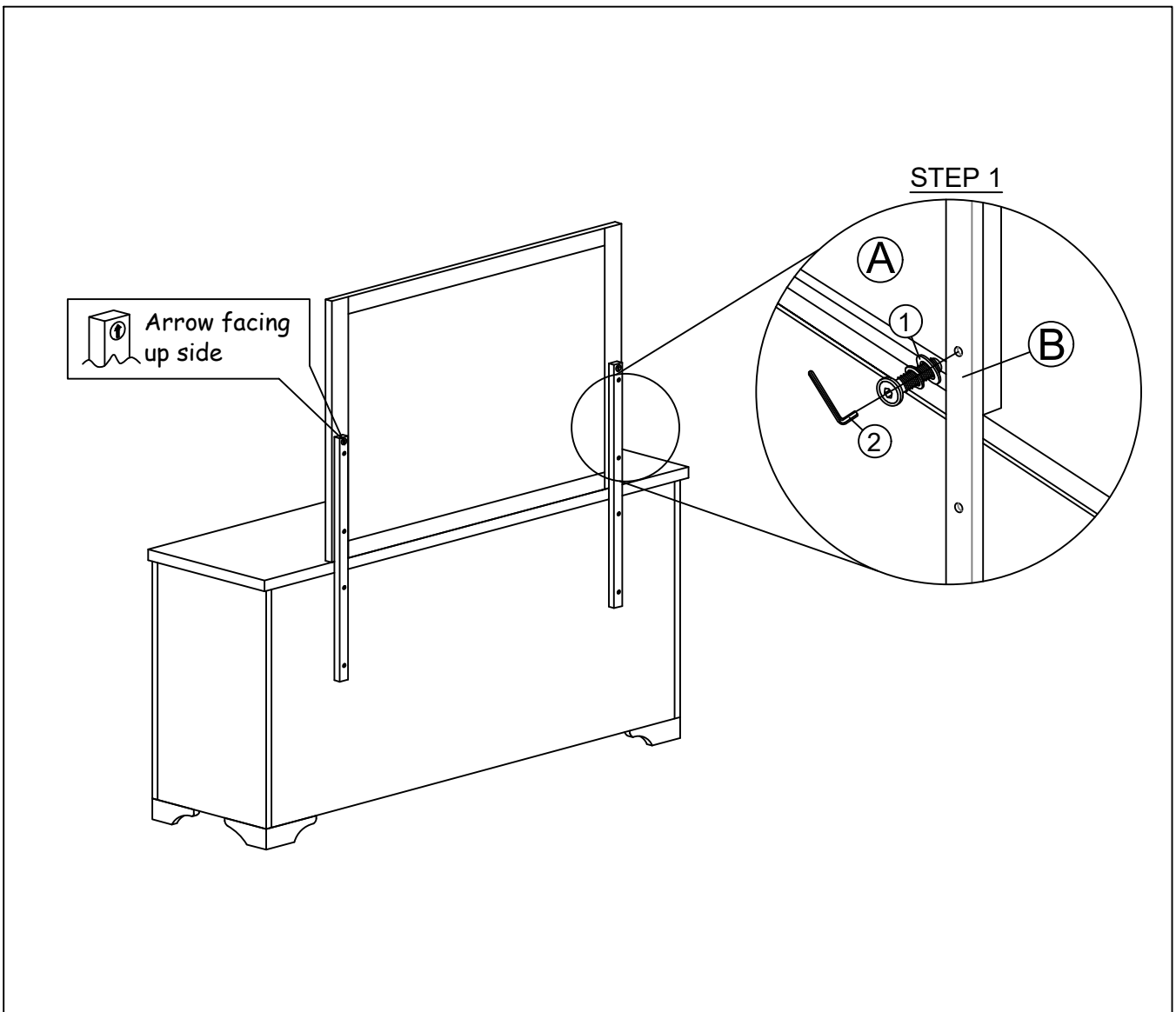

THE HARDWARE IS LOCATED IN THE PACKING ITEMS

NOTE : MUST TIGHTEN SCREWS PERIODICALLY. WITH USE SCREWS MAY BECOME LOOSE.
CHECK TIGHTNESS OF ALL SCREWS EVERY 6-8 WEEKS.

CLEANING INSTRUCTION

After assembled, clean & polish the completed parts if necessary with soft cloth and industrial recognized furniture polish

MADE IN MALAYSIA