

3. Hinge Block to Seat Assembly

Lay backrest over seat assembly. Insert a machine bolt through a hole in a hinge block. Place one washer on the bolt before attaching hinge block to hole in rear portion of the seat assembly. A second washer is placed on the bolt before a locking nut. Repeat on other side.

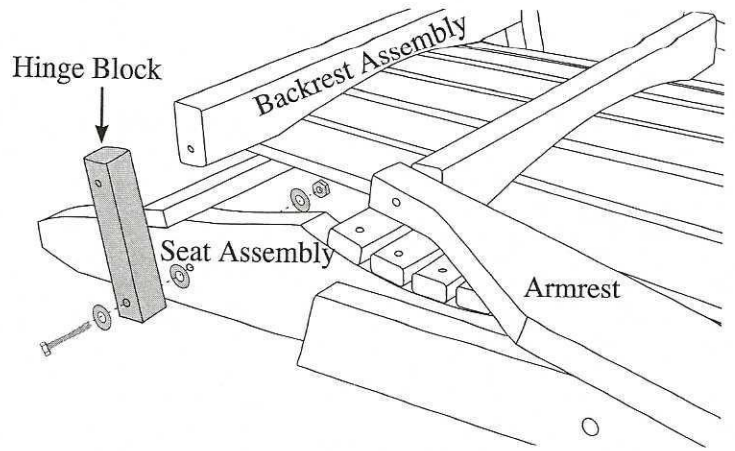

4. Hinge Block to Backrest Assembly

Place one washer on a lag bolt before inserting through remaining hole in hinge block. A second washer is placed on the lag bolt before attaching hinge block to bottom support of backrest assembly. Repeat on other side.

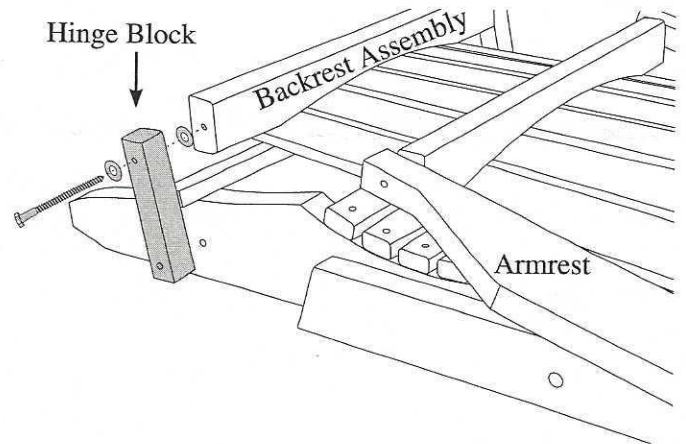

5. Armrest to Backrest Assembly

Place one washer on a lag bolt before inserting through outside hole of armrest. A second washer is placed on the bolt before attaching armrest to center support of backrest assembly. Repeat on other side.

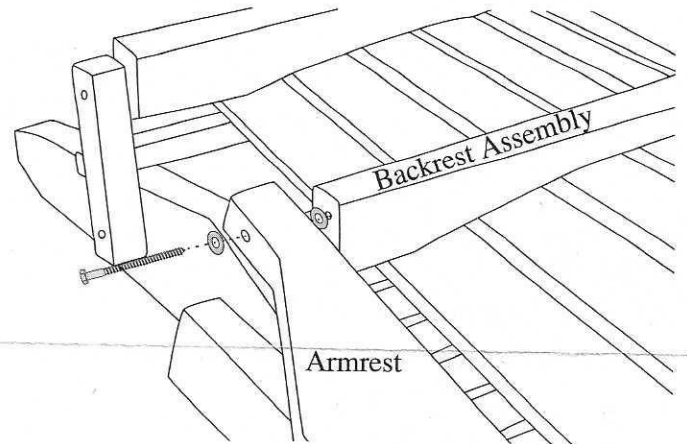

6. Seat Support to Front Legs

Unfold chair and firmly place on a flat surface. Check that hinge block rolled forward completely. Attach seat support to front legs using four wood screws making sure it is pressed against bottom of seat assembly.

