

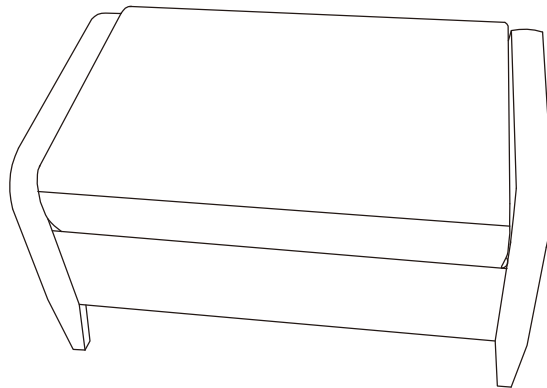

# Outdoor Wicker Ottoman

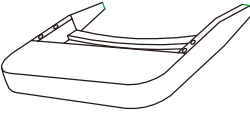

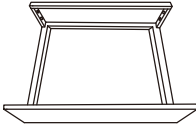
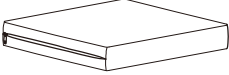

# PART LIST

<b>A</b> 	<b>B</b> 	<b>C</b> 	<b>G</b> 
Side Panel 2 PCS	Seat Panel 1 PC	Seat Cushion Cover * 1 PC	Seat Cushion Core 1 PC

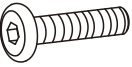

\*Please note cushion covers will ship separately.

# HARDWARE LIST

<b>D</b> 	<b>E</b> 	<b>F</b> 
M6*30mm  Short Bolt 8 PCS (Extra 2)	M6mm  Flat Washer 8 PCS (Extra 2)	M6mm  Allen Wrench 1 PC

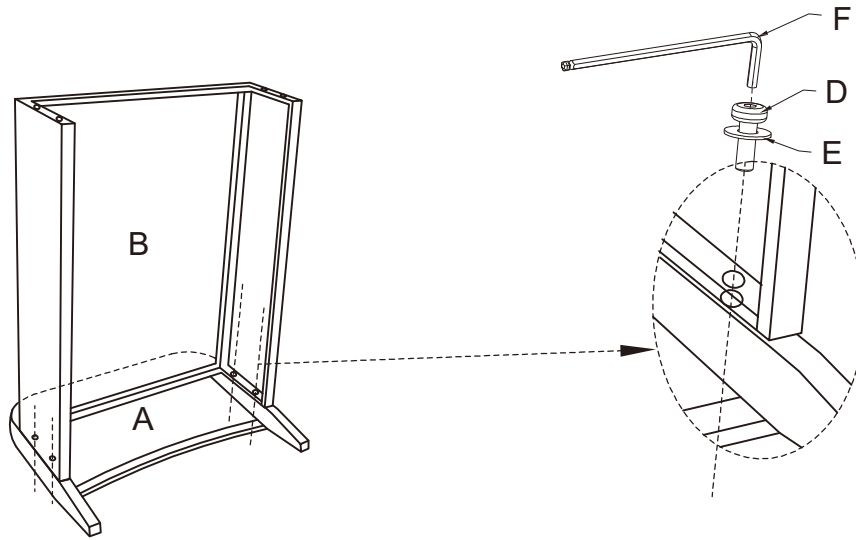

Step 1. Lay side panel (part A) down on a soft flat surface, such as carpet. Attach seat panel (part B) to side panel (part A) using short bolts (part D), flat washers (part E) and allen wrench (part F).  
 NOTE: Please do not fully tighten bolts until unit is fully assembled.

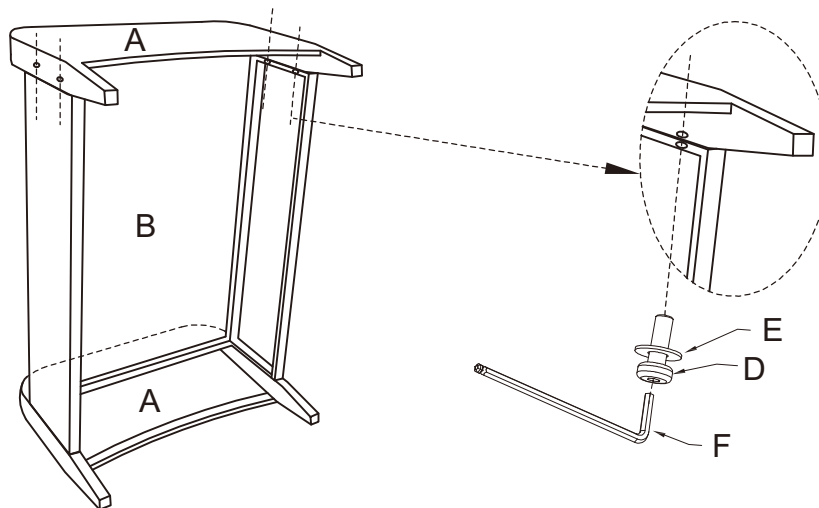

- |   |   |    |
|---|---|----|
| D |  | x4 |
| E |  | x4 |
| F |  | x1 |

Step 2. Attach side panel (part A) to seat panel (part B) using short bolts (part D), flat washers (part E) and allen wrench (part F).  
 NOTE: Please fully tighten all bolts at this time.



- |   |   |    |
|---|---|----|
| D |  | x4 |
| E |  | x4 |
| F |  | x1 |

Step 3. Insert seat cushion core (part G) into seat cushion cover (part C).

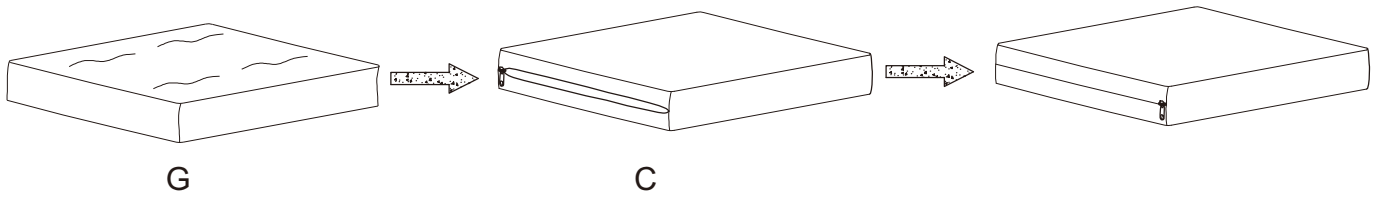

Step 4. Place seat cushion as shown below.

