

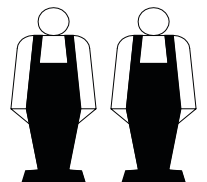

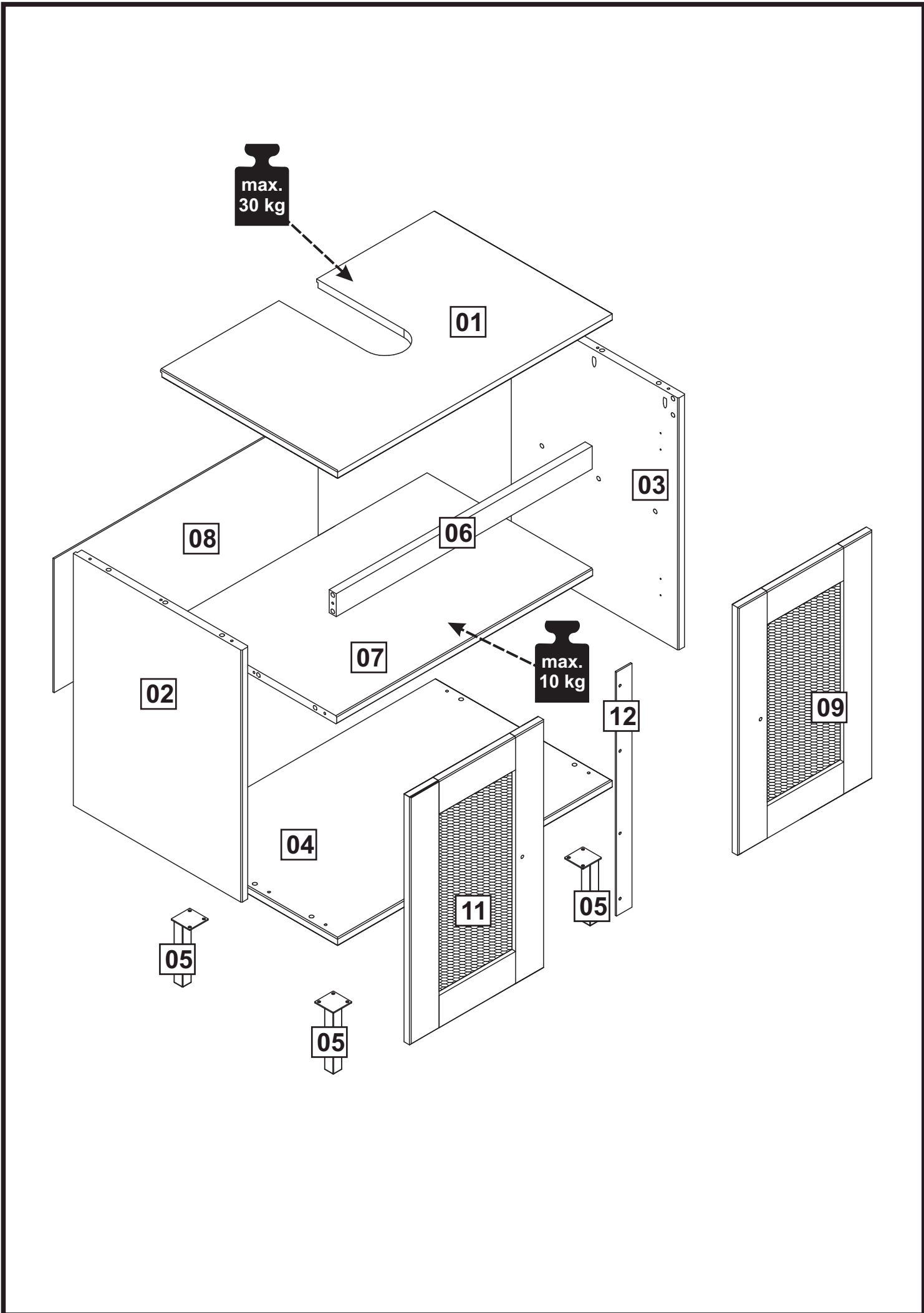





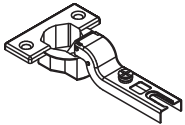

60min.



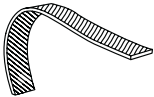
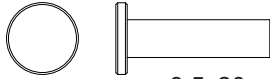
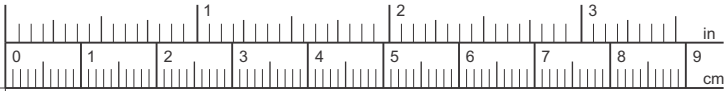
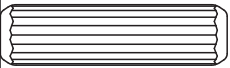

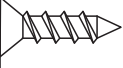
<b>K</b>		<b>02</b>	<b>S</b>		<b>04</b>
<b>L</b>		<b>18</b>	<b>T</b>		<b>02</b>
<b>R</b>		<b>04</b>	<b>U</b>		<b>01</b>
			<b>X</b>	 9,5x20mm	<b>02</b>

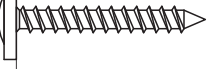
		
<b>A</b> x22		<b>8,0x30</b>
<b>B</b> x14		<b>4,0x30</b>
<b>C</b> x02		<b>M3x8</b>
<b>D</b> x33		<b>4,0x16</b>
<b>E</b> x06		<b>4,0x40</b>
<b>J</b> x04		<b>4,5x25</b>



# 03

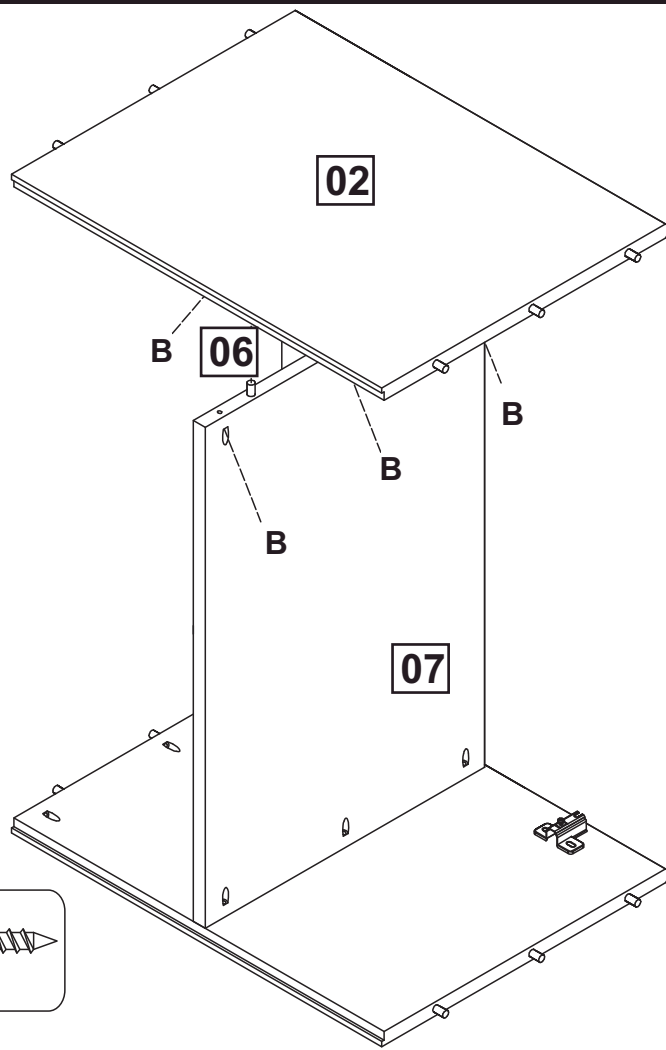

# 04

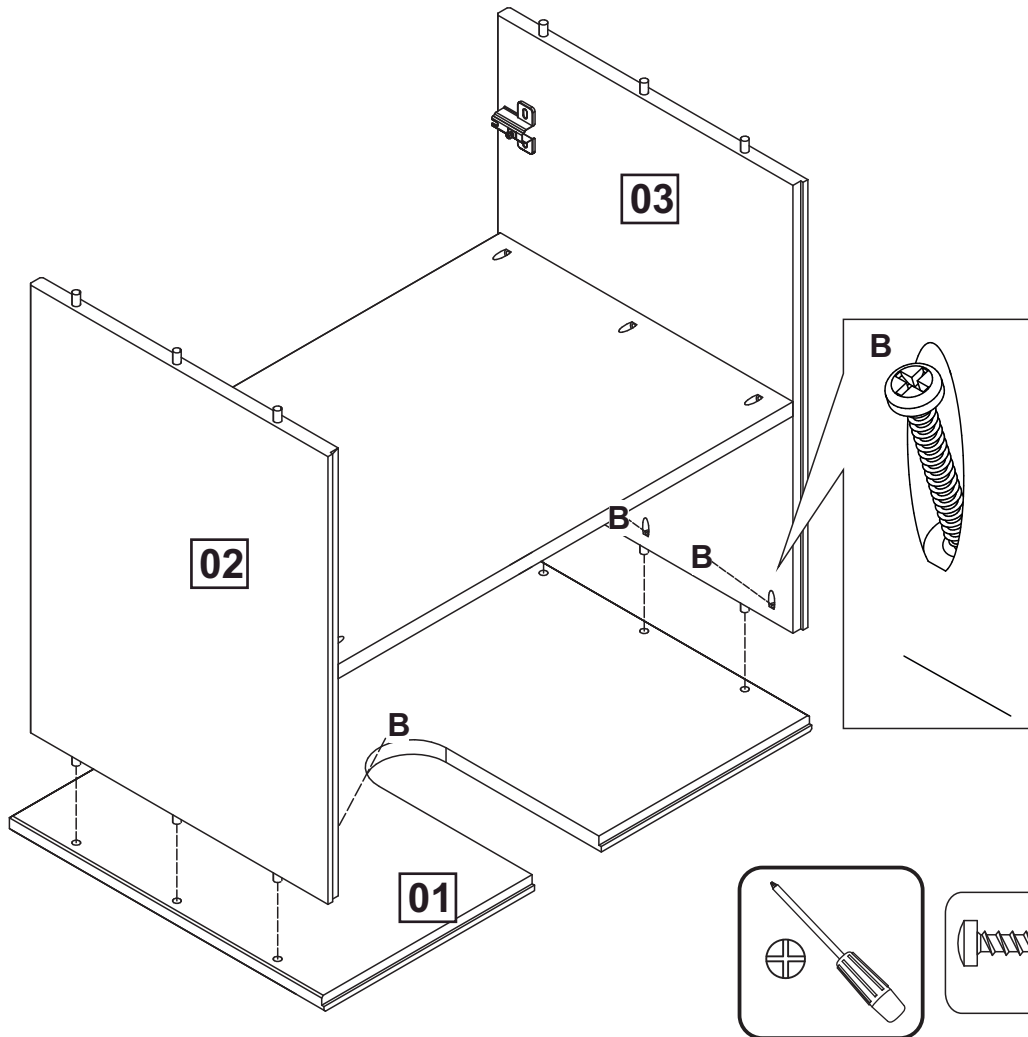

**05**

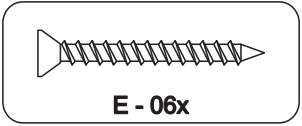
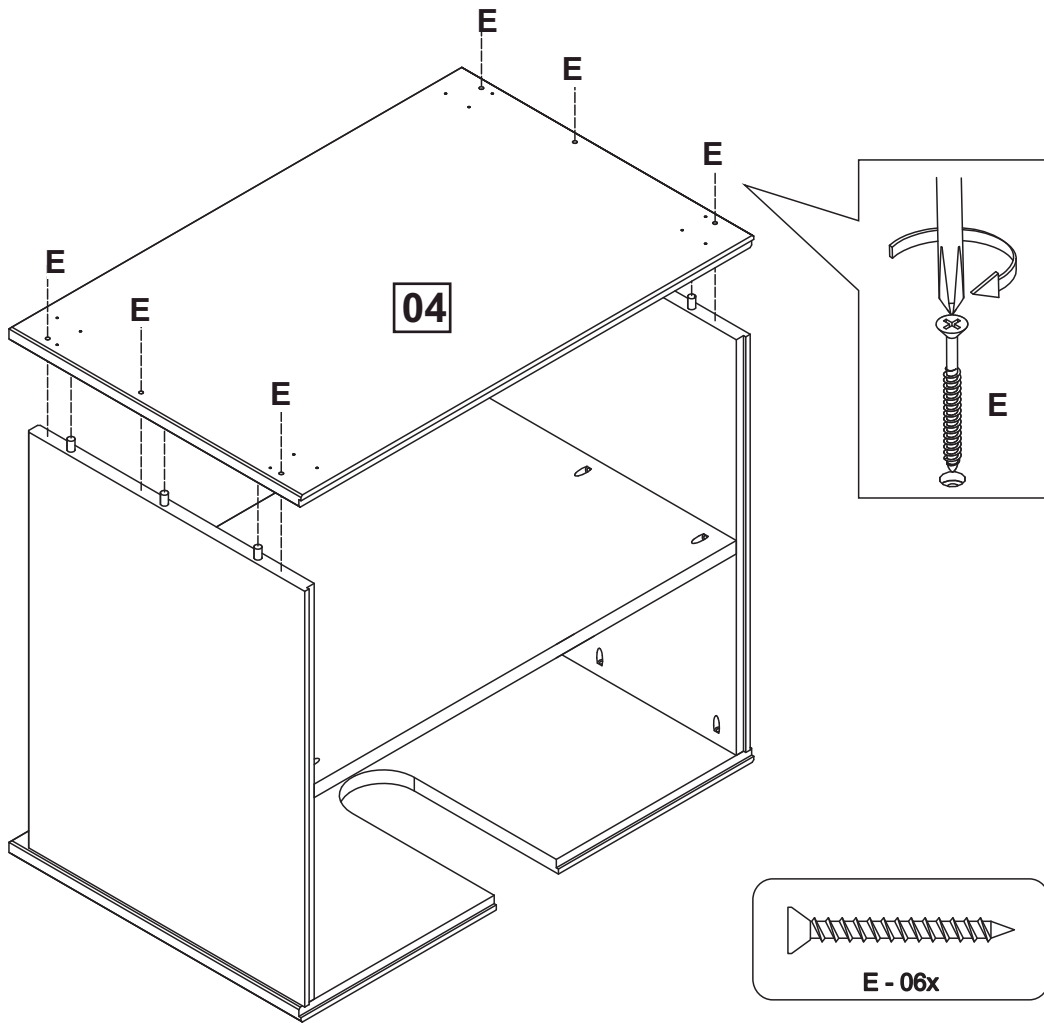

**06**

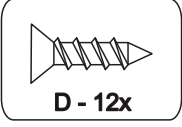
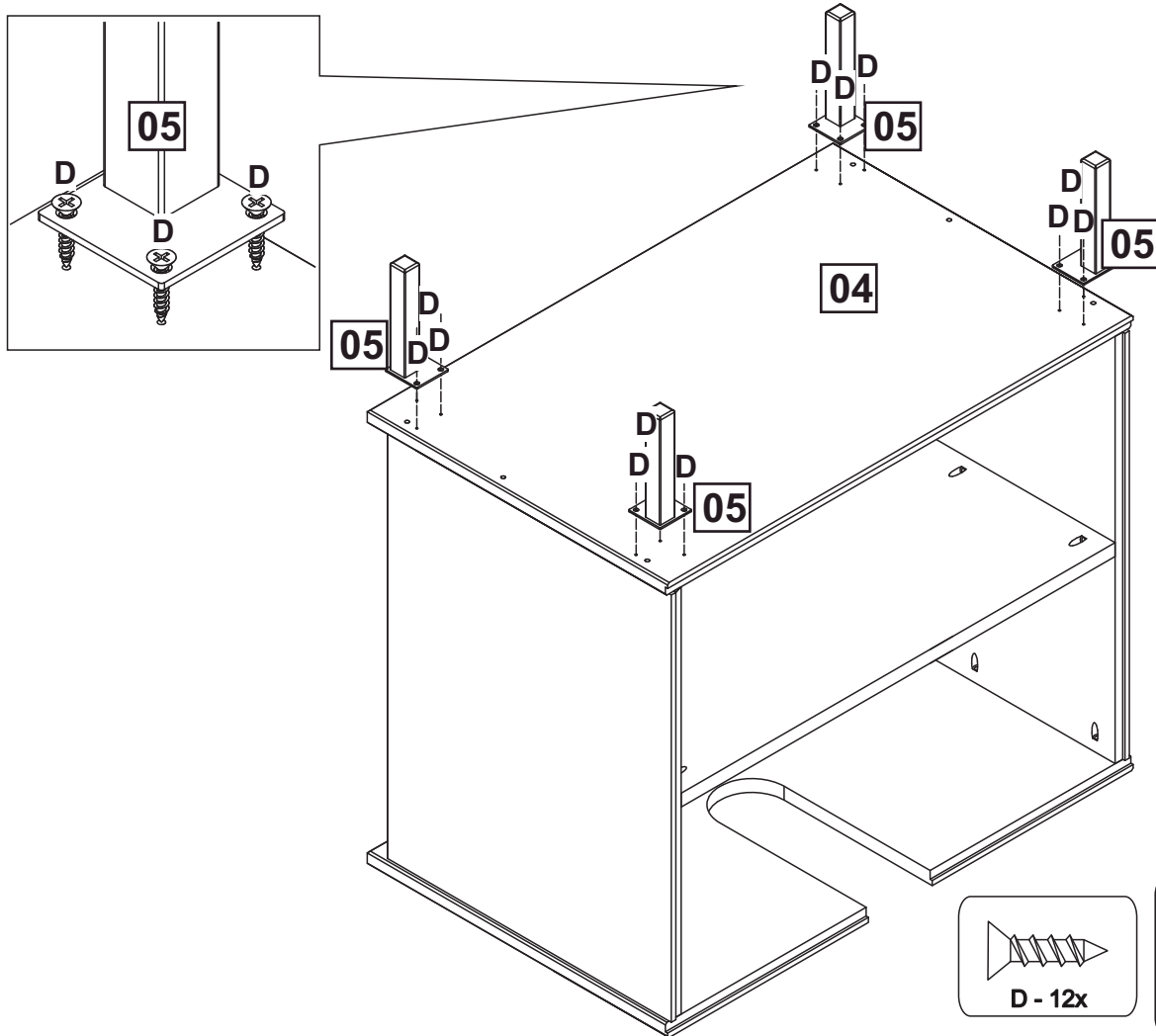

**07**

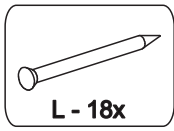
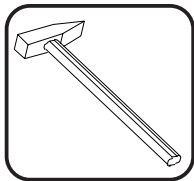
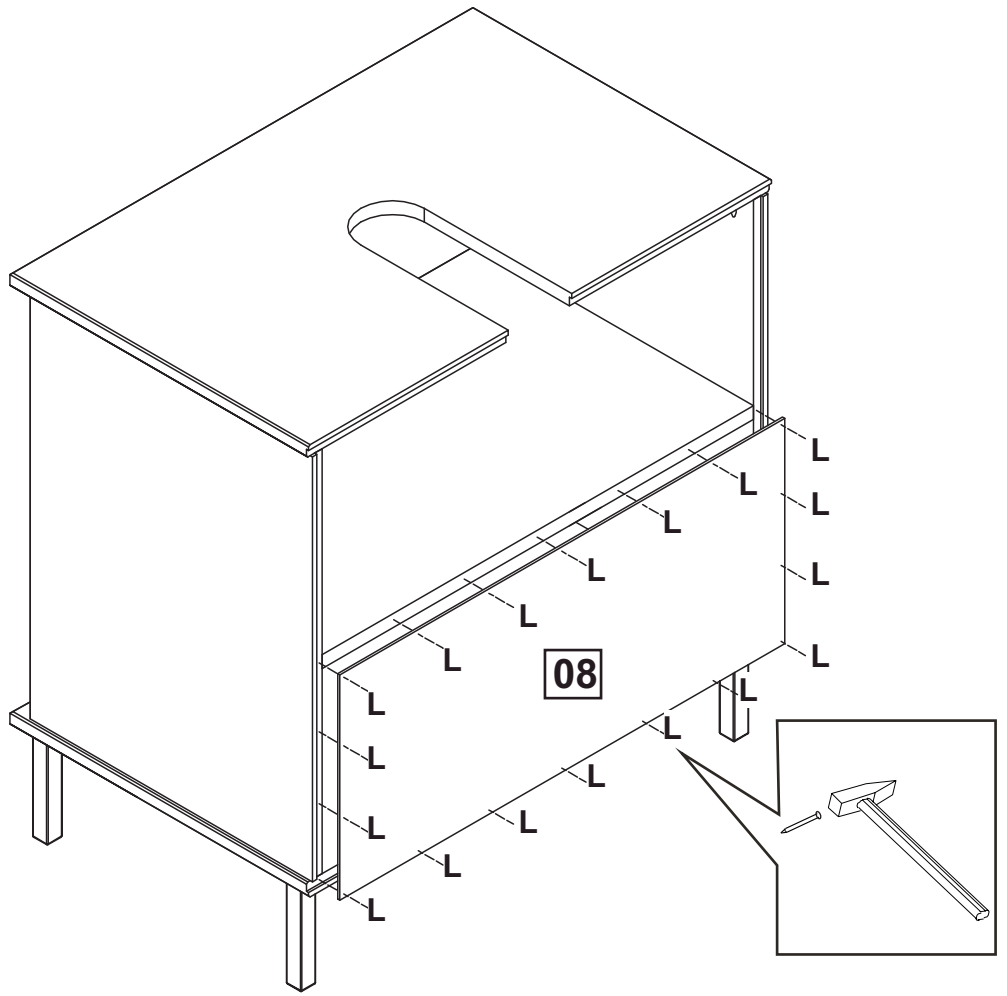
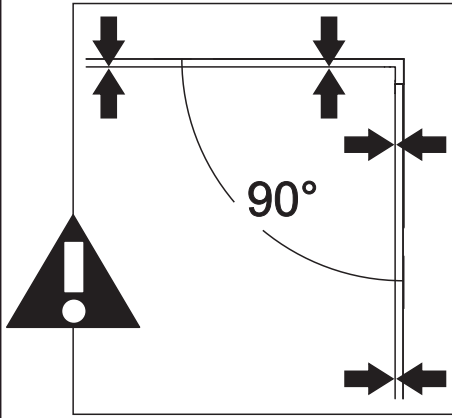

**08**

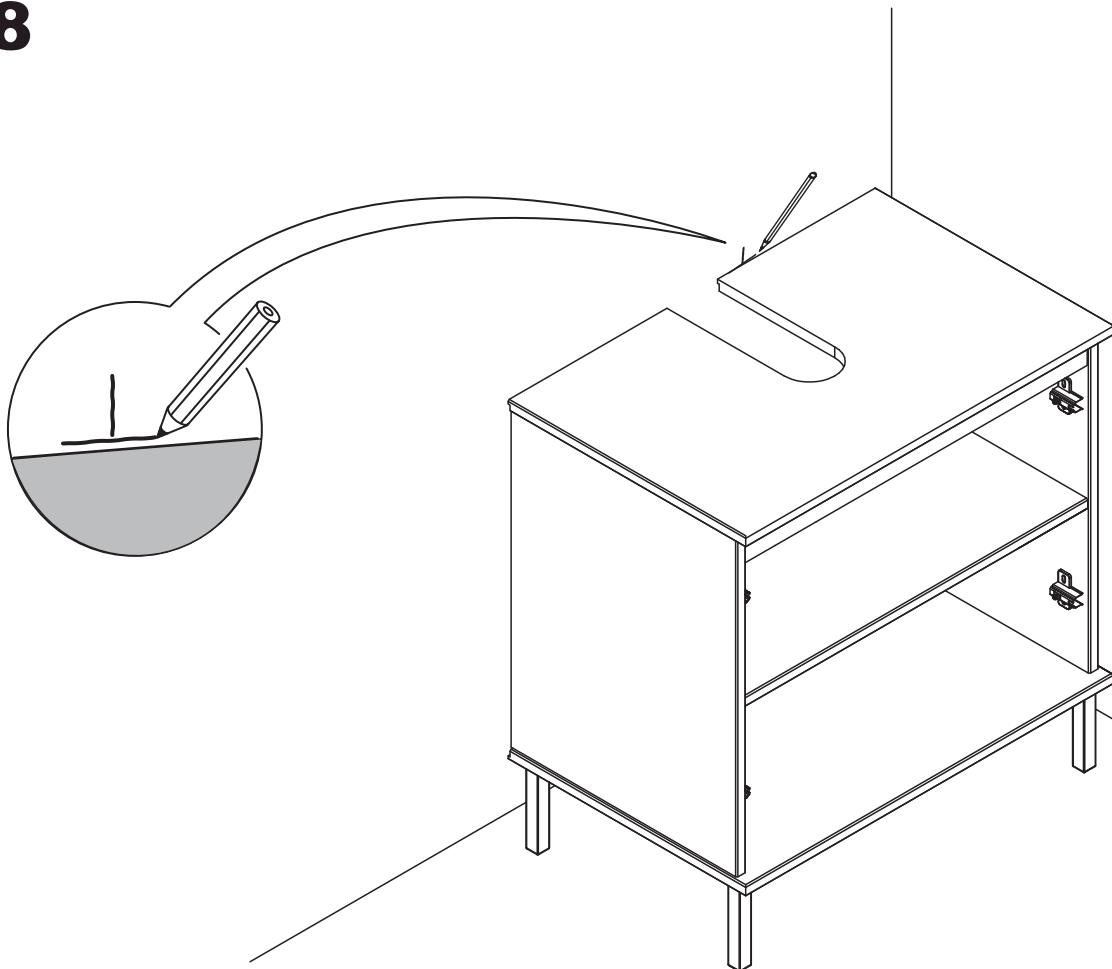

## German

**WICHTIG:** Um ein versehentliches Kippen des Möbels zu vermeiden, ist die Befestigung an der Wand zwingend vorgeschrieben.  
Die benötigten Schrauben zur Wandbefestigung, welche von der Beschaffenheit der Mauer abhängen, sind nicht in der Lieferung enthalten. Wenden Sie sich bitte bei Zweifel an einen Spezialisten.

## English

**IMPORTANT:** To avoid the accidental tip-over of the furniture, the fixing of the furniture on the wall is mandatory.  
The needed hardware for the junction wall/furniture, depending of the nature of the wall, is not provided. If any doubt, consult a specialist.

## French

**IMPORTANT:** Pour éviter le basculement accidentel du meuble, la fixation du meuble au mur est obligatoire.  
La visserie necessarie pour lá jonction mur/meuble, dépendante de la nature du mur, n'est pas fournie. En cas de doute, consulter un spécialiste.

## Italian

**IMPORTANTE:** Per evitare il ribaltamento accidentale del mobile è obbligatorio il fissaggio a muro. I tasselli necessari per il collegamento mobile\muro, dipendenti dal tipo di muro, non sono provvisti.  
Consultare uno specialista in caso di dubbi.



Es gibt eine Vielzahl verschiedener Arten von Mauern oder Zwischenwänden, und aus diesem Grunde können wir Ihnen den genau entsprechenden Befestigungstyp nicht bereitstellen. Zunächst ist es erforderlich, die exakte Bauart der Wand zu ermitteln, an der Sie dieses Produkt anbringen werden, um die für diese Wand geeigneten Befestigungsmittel im Fachhandel erwerben zu können. Nachfolgend einige Beispiele empfohlener Befestigungen für:



**VOLLWÄNDE**

**NYLONDÜBEL „FISCHER“**

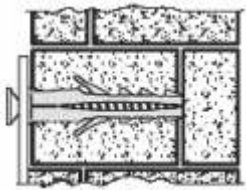
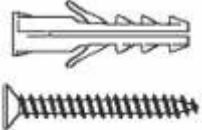

**ANKERDÜBEL AUS METALL**

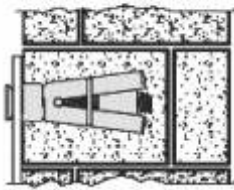
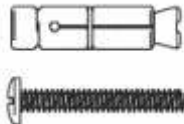

**ANKERDÜBEL MIT NYLONFLÜGELN**

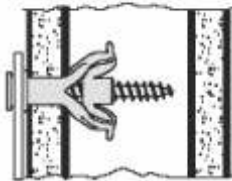
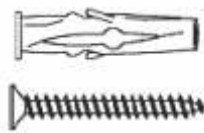

**HOHLWÄNDE**

**SPREIZDÜBEL FÜR VERANKERUNG AUS METALL**

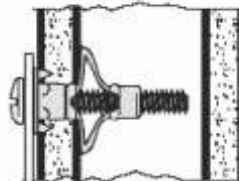
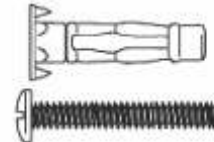

**MOLLY-DÜBEL**

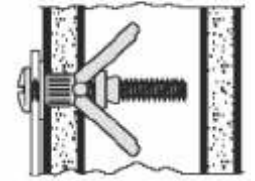

Bitte verwenden Sie eine für die Eisenwaren und den Wandtyp geeignete Bohrergröße.



Due to the wide diversity of wall or partition types, we cannot provide you with suitable attachment fixtures. To determine which attachment fixtures to use, you will need to identify the type of wall to which you will be fixing this product. Here are some examples of attachment fixtures recommended for:



**BLIND WALLS**

**"FISCHER" Nylon plug**

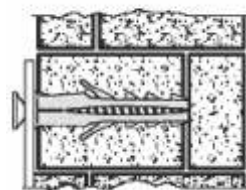
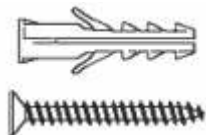

**Metal Wall plug**

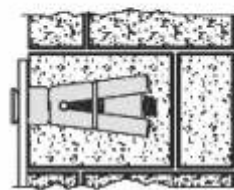
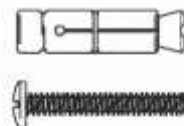

**Nylon winged Wall plug**

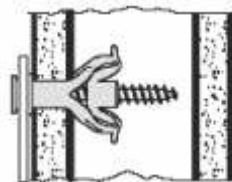
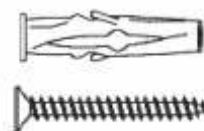

**STUDDED WALLS**

**Metal expansion plug**

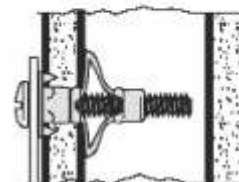
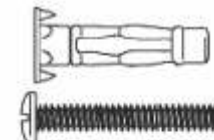

**"MOLLY"plug**

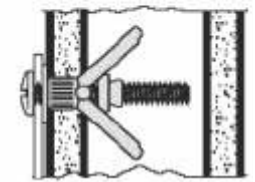
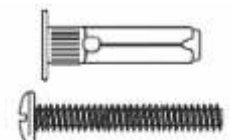

Use a drill bit that is compatible in size with the hardware used and the type of wall.



Il existe une grande diversité de types de murs ou cloisons, c'est la raison pour laquelle nous ne pouvons vous fournir le type exact de fixation. Il est nécessaire d'identifier le type de paroi à laquelle vous allez fixer ce produit afin de vous procurer les fixations appropriées. Voici quelques exemples de fixations conseillées pour:



**LES MURS PLEIS**

**Cheville nylon "FISCHER"**

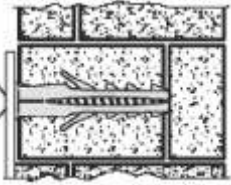
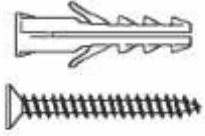

**Cheville d'ancrage métal**

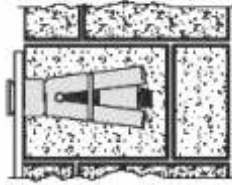
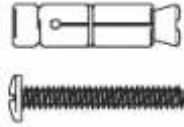

**Cheville d'ancrage  
À ailettes en nylon**

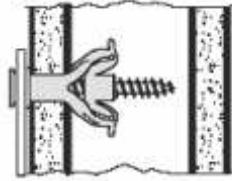
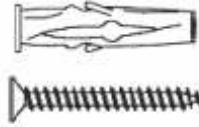

**LES CLOISONS CREUSES**

**Cheville métallique  
À expansion**

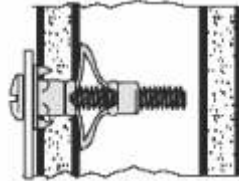
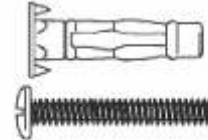

**Cheville "MOLLY"**

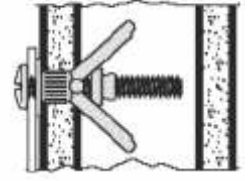
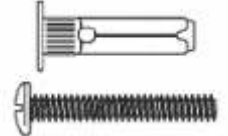

Utiliser une taille de forêt adaptée à la quincaillerie utilisée et au type de mur.



Esiste una gran varietà di tipi di muri o paratie e noi siamo in grado di fornirvi il tipo esatto di fissaggio per ognuno di essi. E' necessario identificare il tipo di parete alla quale intendete fissare questo prodotto in modo da fornirvi i fissaggi più idonei. Ecco qualche esempio di fissaggi consigliati per :



**I MURI PIENI**

**TASSELLO NYLON  
"FISCHER"**

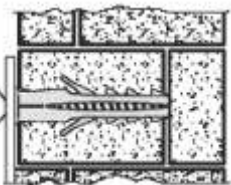
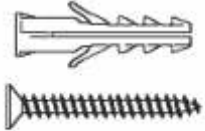

**TASSELLO DI  
ANCORAGGIO IN  
METALLO**

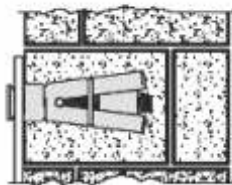
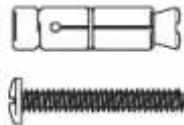

**TASSELLO DI  
ANCORAGGIO AD  
ALETTE IN NYLON**

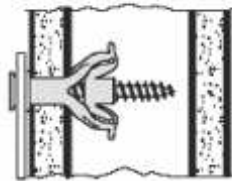

**PARATIE CAVE**

**TASSELLO METALLICO  
AD ESPANSIONE**

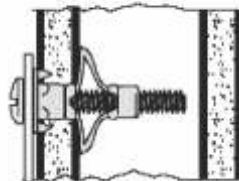
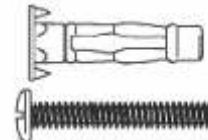

**TASSELLO  
"MOLLY"**

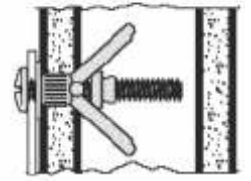

Utilizzare una punta di trapano adatta agli utensili utilizzati e al tipo di muro.

09



OBLIGATORISCHE BEFESTIGUNG AN DER WAND

OBLIGATORY FIX ON THE WALL

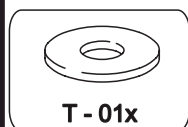
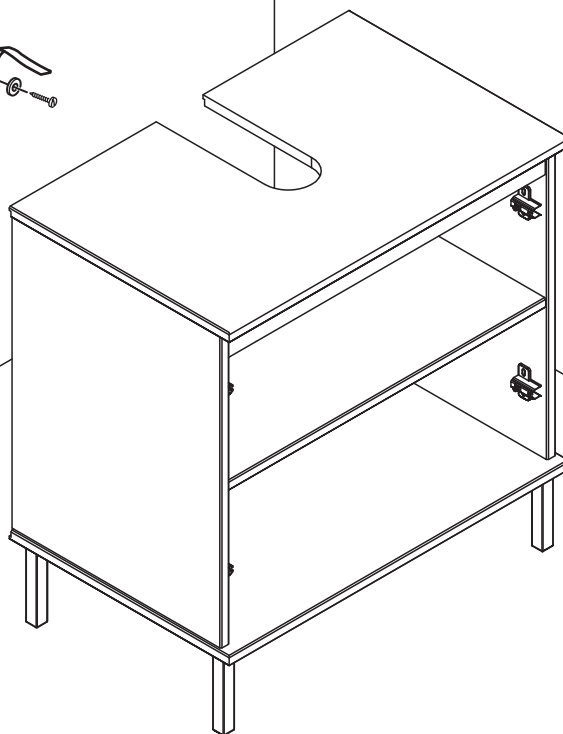
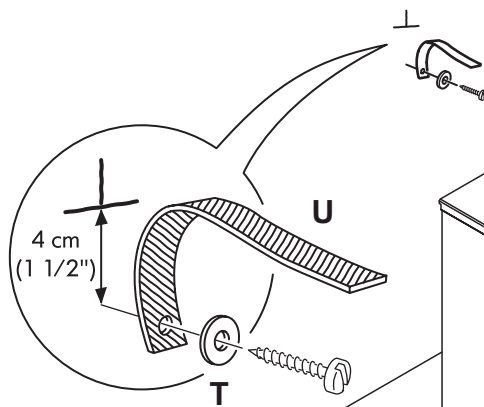

T-01x

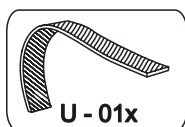

U-01x



10

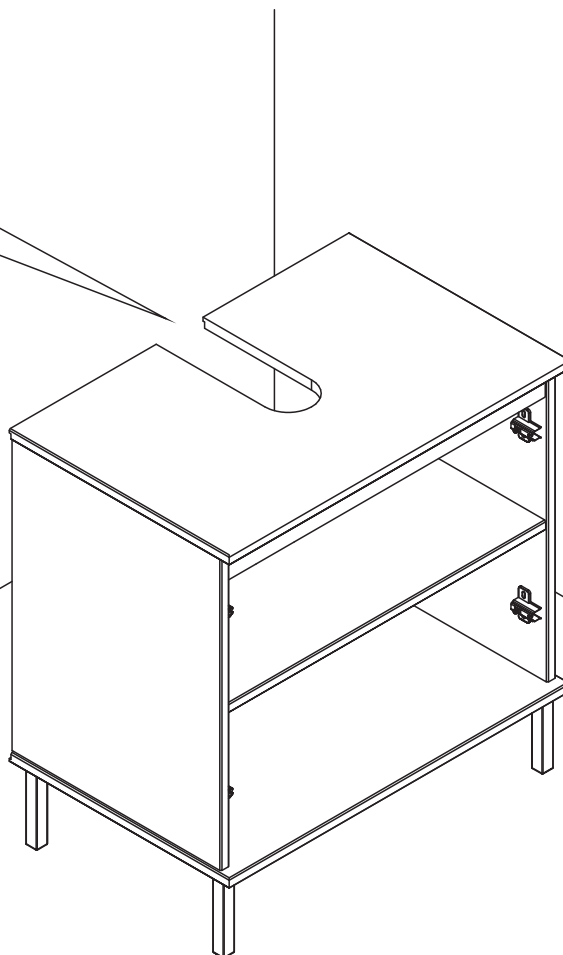
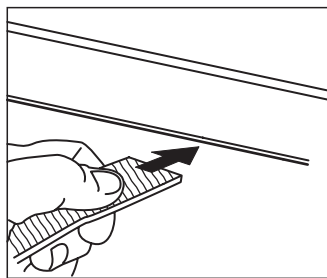

# 11

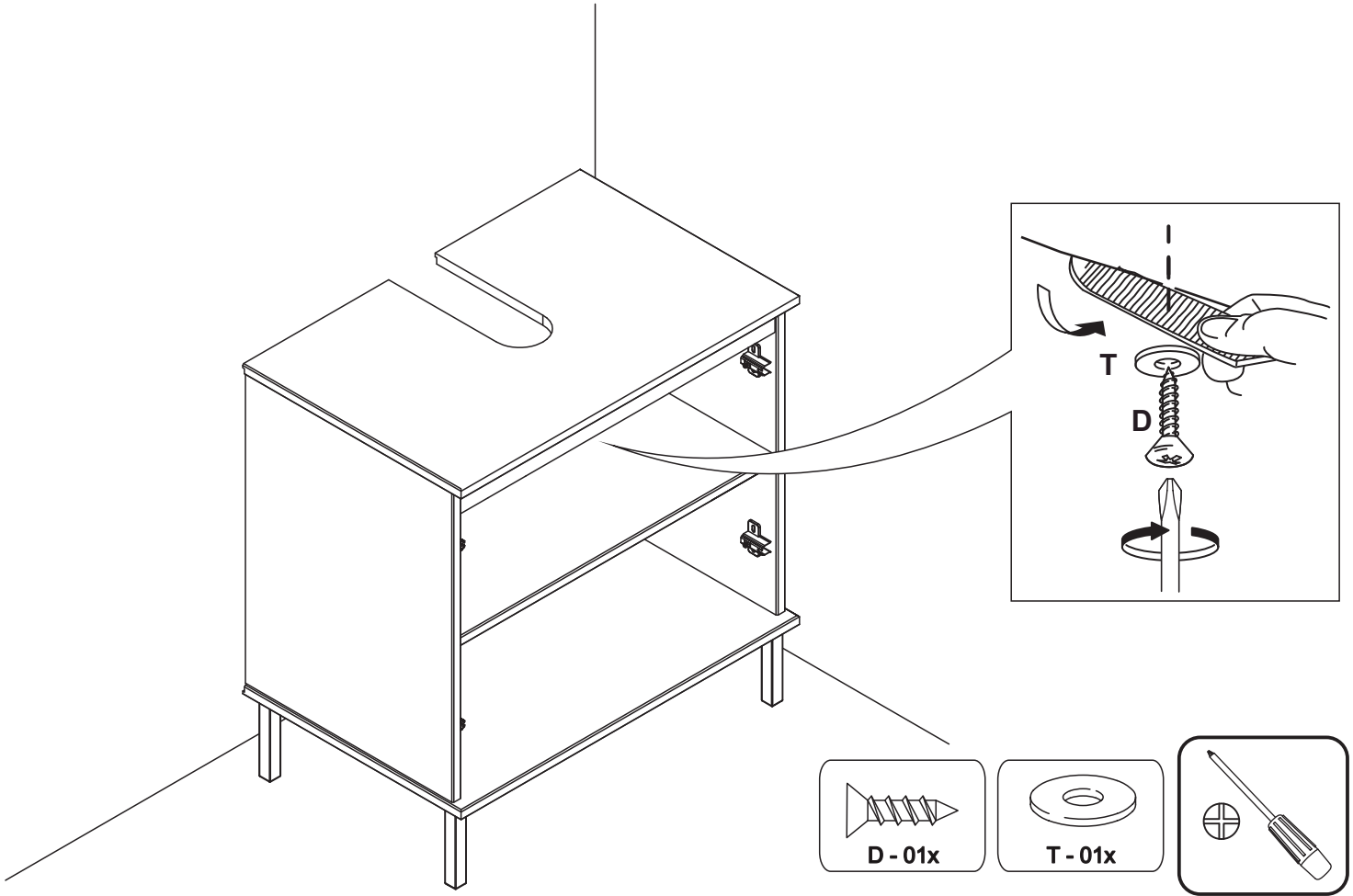

# 12

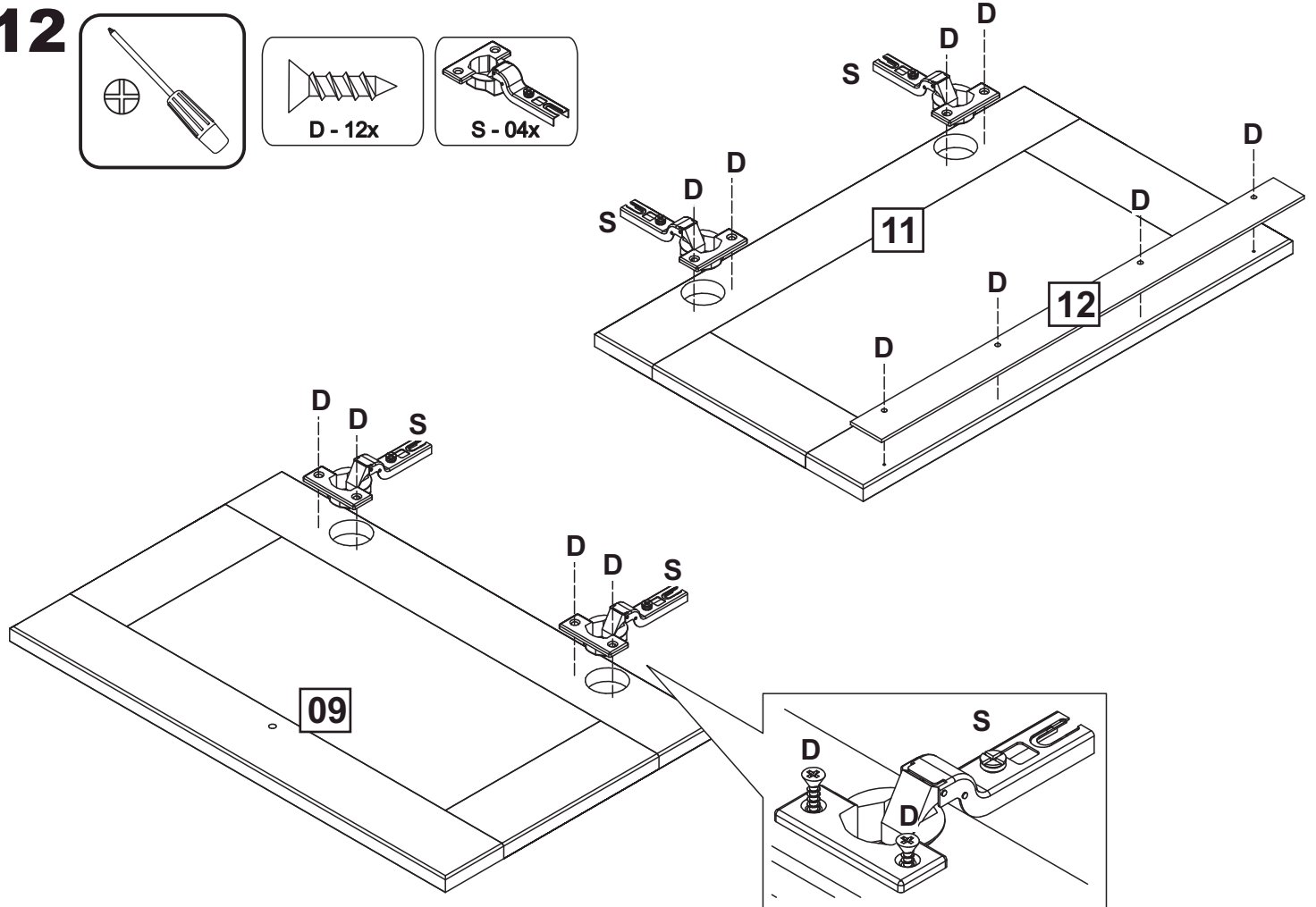

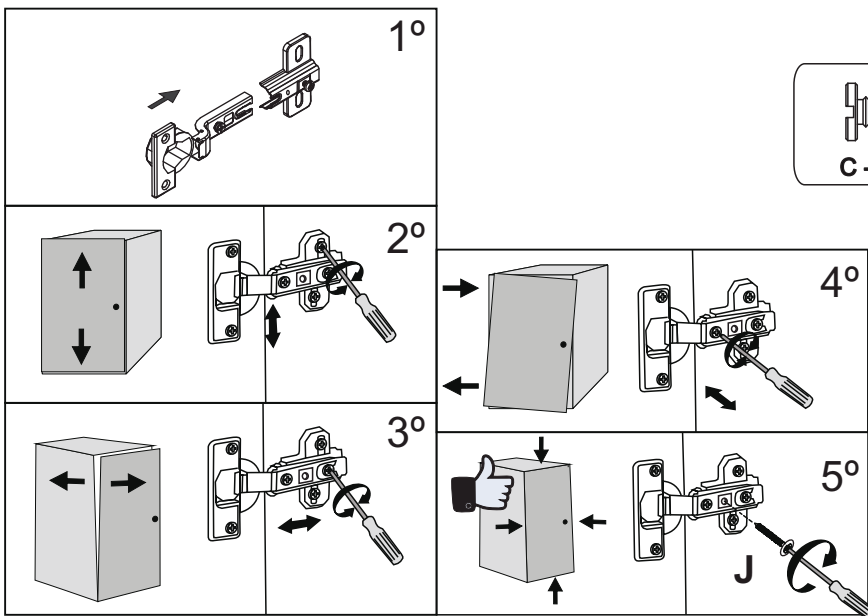
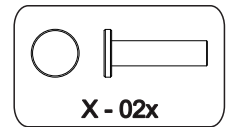
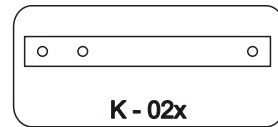
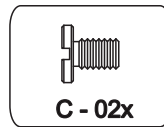
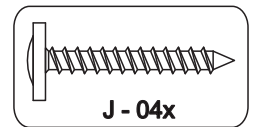
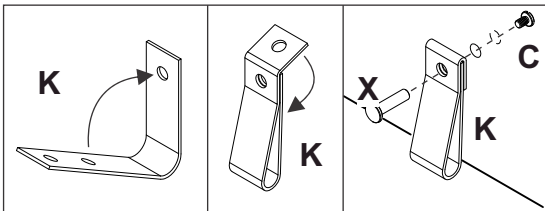
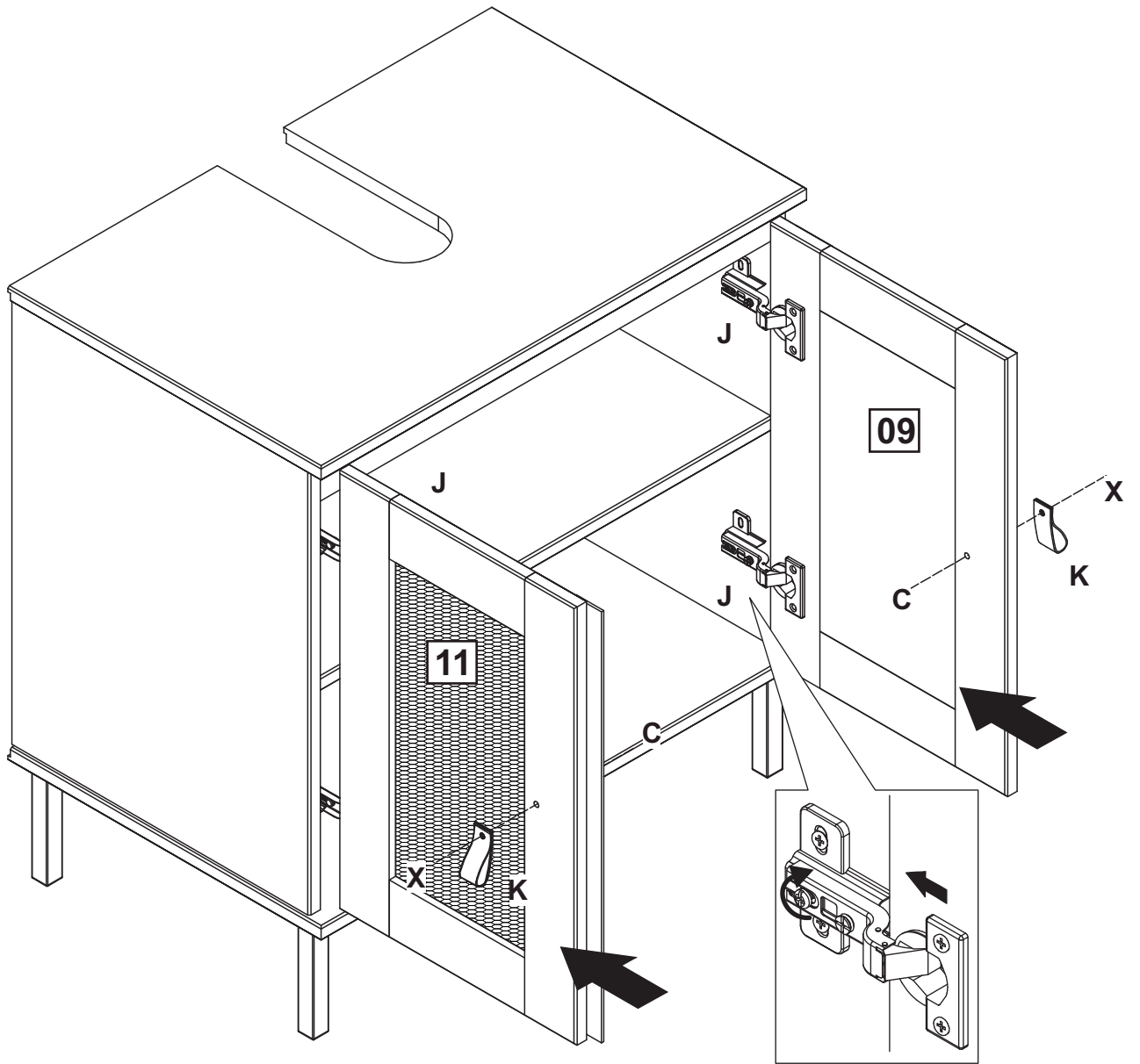





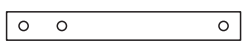

# SERVICEKARTE

## Unser Direktbestellservice für Sie:

Sollte ein Beschlagteil fehlen oder ein Bauteil defekt sein, können Sie gerne direkt unter **114** kontaktieren, oder uns eine E-Mail senden mit Art. Nr. der Ausführung und der genauen Nummer des Beschlagteils/Bauteils, mit der Angabe der Fehlmenge. Am besten senden Sie ein Bild der ausgefüllten Servicekarte an **114** um eine korrekte und schnelle Bearbeitung zu ermöglichen. Bitte immer auch Bilder des defekten Teils mitschicken. Vielen Dank.

<b>K</b>		<b>02</b>	<b>S</b>		<b>04</b>
<b>L</b>		<b>18</b>	<b>T</b>		<b>02</b>
<b>R</b>		<b>04</b>	<b>U</b>		<b>01</b>
			<b>X</b>	 9,5x20mm	<b>02</b>

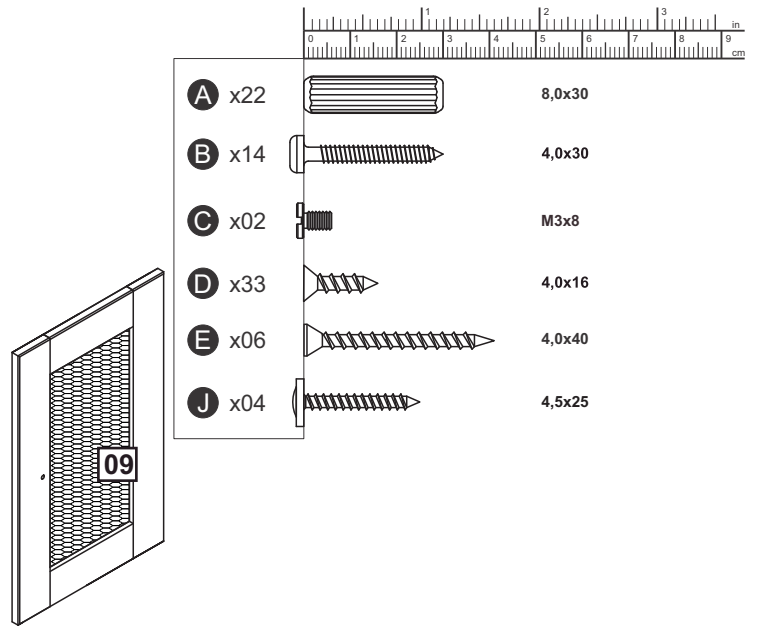
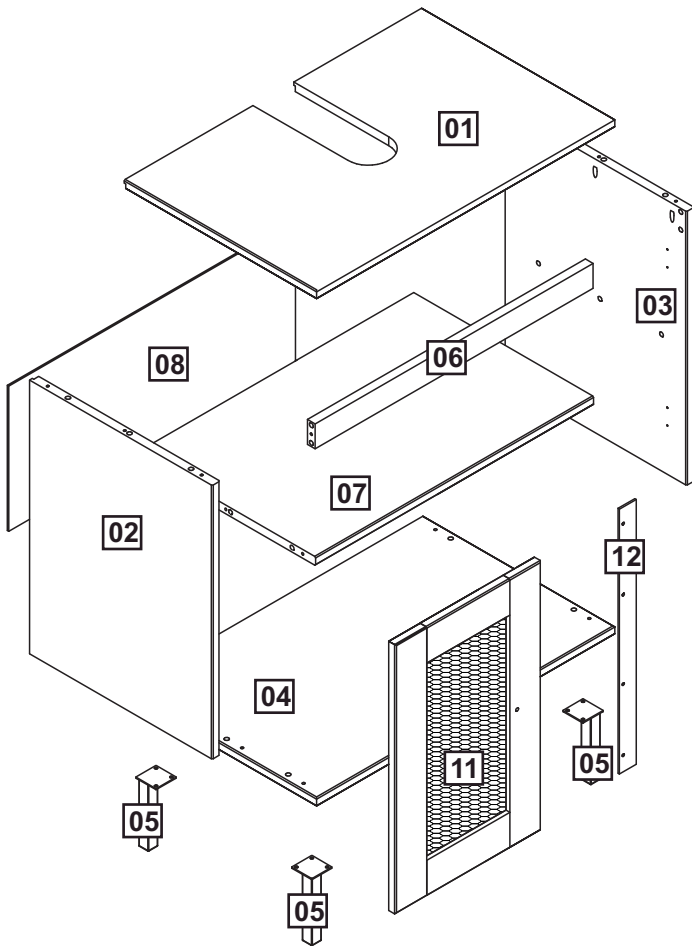

Bitte in diesem Bereich die benötigten Mengen vermerken!

Grund der Beanstandung:.....

Gekauft bei:.....Gekauft am:.....

Auftrags-Nr.:.....

Für Rückfragen: Telefon .....E-Mail.....

Gewünschte Versandadresse:

Name:.....

PLZ:.....Ort.....Straße, Nr.:.....