

INSTRUCTION MANUAL ENCLOSED

ATTENTION

**IF YOU HAVE ANY PROBLEMS OR QUESTIONS, EMAIL OR CALL
CUSTOMER SERVICE BEFORE YOU RETURN THIS PRODUCT TO THE
STORE WHERE IT WAS PURCHASED.**

****When emailing Customer Service, please include your **Order Number** and **platform of purchase** in the email subject for quicker assistance.**

INSTRUCTION MANUAL ENCLOSED

CLUB CHAIR

CLUB CHAIR ASSEMBLY INSTRUCTION

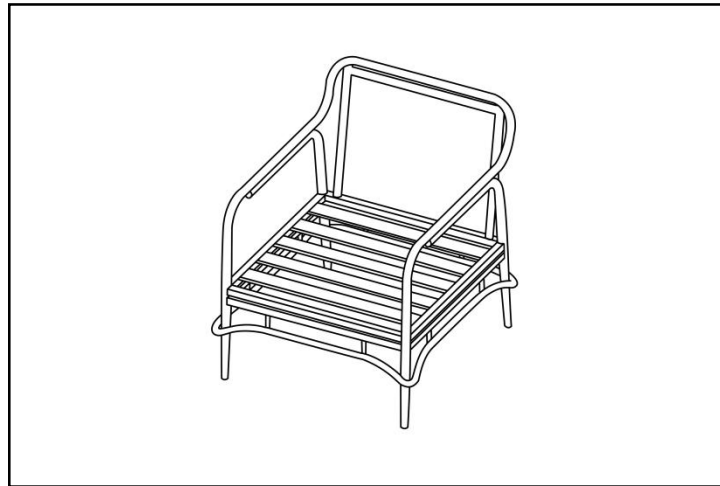

| Part | PARTS LIST Description | Quantity |
|------|---------------------------|----------|
| | <i>PARTS</i> | |
| A | Top Frame | 1 |
| B | Under Frame | 1 |
| | <i>HARDWARE</i> | |
| C | Bolts(M6*35MM) | 4 |
| D | Allen Key | 1 |

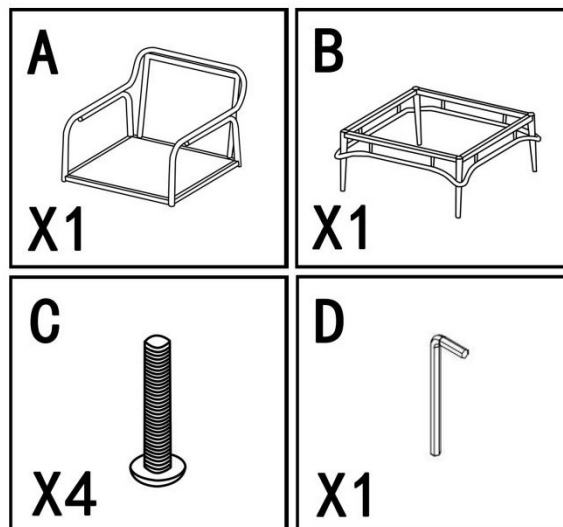

PLEASE READ AND FOLLOW ALL SAFETY TIPS

GETTING STARTED

1. Before assembly, CAREFULLY use scissors or utility knife to cut and unwrap all parts. Make sure you do not discard the hardware.
2. Make sure that you have all the parts listed. If you are missing any parts, please email us. Please identify the parts you need and model number. Make sure to include your name and address.
3. Please include your **Order Number** and **platform of purchase** in the email subject, and one of our customer service representative will get back to you.

Warm Tips:

1. The plastic covers on some metal parts are just for product protection. Please remove it before assembly.
2. Please follow the sequence of AI during assembly.
3. Do not tighten the screws until all of them are in right positions.

1. Locate Top Frame(A) to the Under Frame(B) by the pre-drilled Threads. (Photo 1)

STEP1

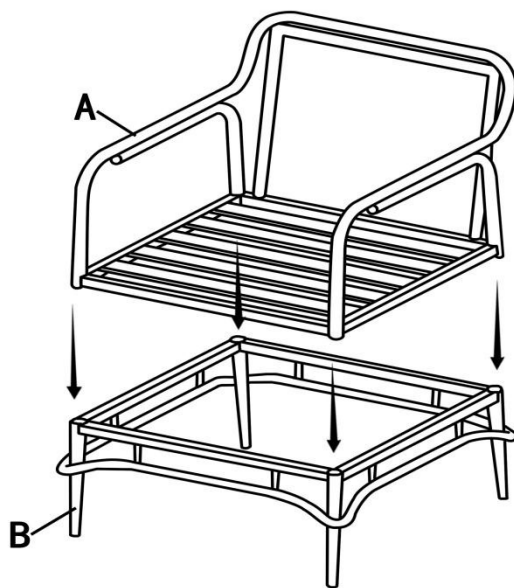

2. Turn over the Chair frame carefully, Use Allen Key(D) to fasten Bolts(C), Then turn over the Chair to the upright position carefully.

STEP2

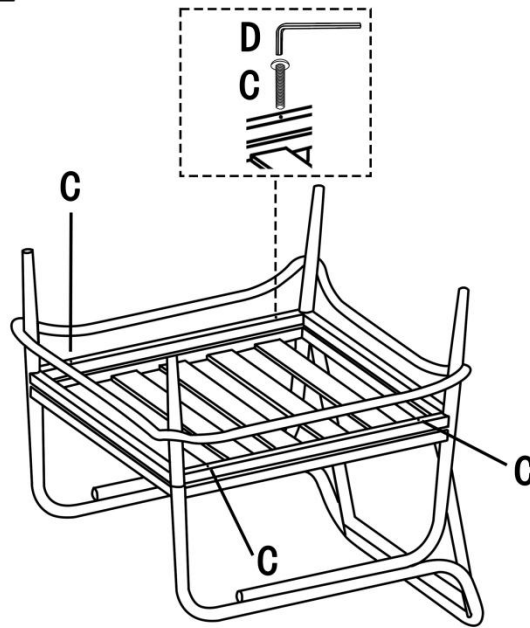

3. Follow the same instruction for the other Club chairs.

Till now you have finished the whole assembly and enjoy your club chairs.

INSTRUCTION MANUAL ENCLOSED

OUTDOOR SIDE TABLE

OUTDOOR SIDE TABLE INSTRUCTION

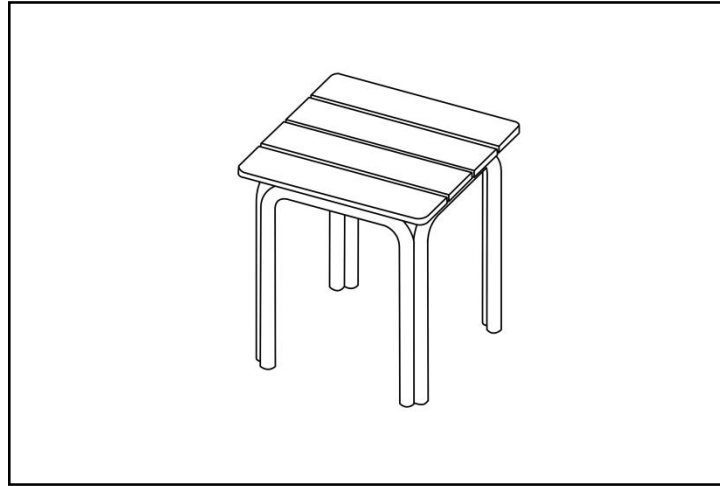

| Part | PARTS LIST Description | Quantity |
|-----------------|---------------------------|----------|
| <i>PARTS</i> | | |
| A | Table Feet | 4 |
| B | Table Top | 1 |
| <i>HARDWARE</i> | | |
| C | Bolts(6X50mm) | 8 |
| D | Bolts(6X40mm) | 4 |
| E | Allen Key | 2 |

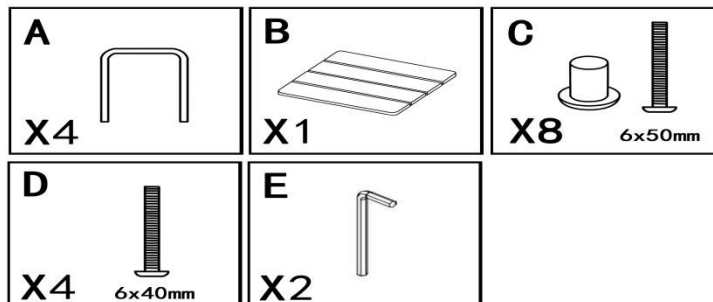

PLEASE READ AND FOLLOW ALL SAFETY TIPS

GETTING STARTED

1. Before assembly, CAREFULLY use scissors or utility knife to cut and unwrap all parts. Make sure you do not discard the hardware.
2. Make sure that you have all the parts listed. If you are missing any parts, please email us. Please identify the parts you need and model number. Make sure to include your name and address.
3. Please include your **Order Number** and **platform of purchase** in the email subject, and one of our customer service representative will get back to you.

Warm Tips:

1. The plastic covers on some metal parts are just for product protection. Please remove it before assembly.
2. Please follow the sequence of AI during assembly.
3. Do not tighten the screws until all of them are in right positions.

1.Position each Table Foot(A) by the pre-drilled threads. (Photo 1)

STEP1

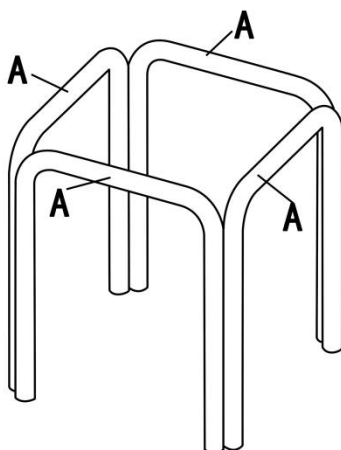

2. Use two Allen Key(E) to secured and fasten Bolts(C). Each foot should have 2 bolts fastened, total have 8 bolts fastened.(Photo 2)

STEP2

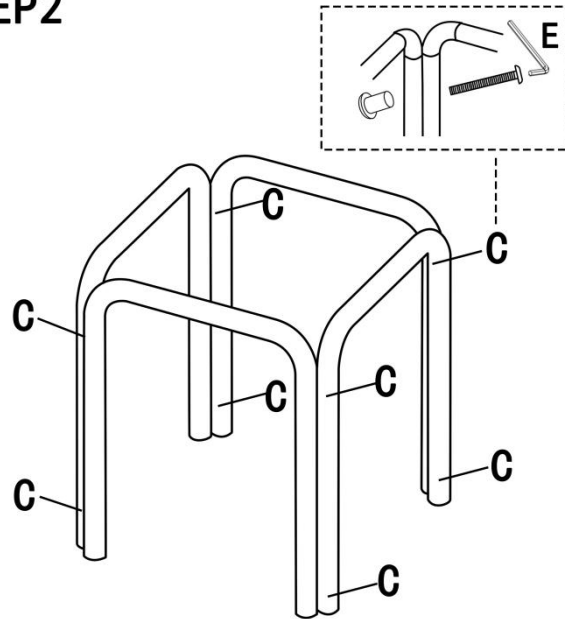

3. Put the Feet frame to the Table Top carefully, Use Allen Key(E) to fasten Bolts(D), Then turn over the Table to the upright position carefully. (photo 3)

STEP3

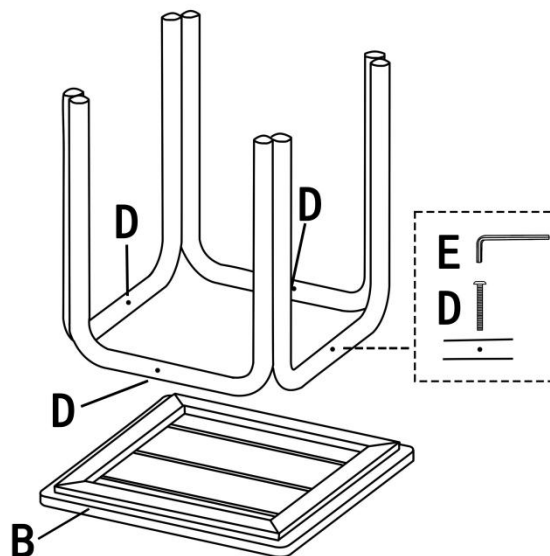

You have completed assembling the furniture – enjoy!