

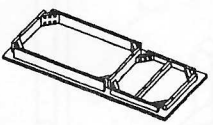







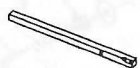

BREAKFAST TABLE

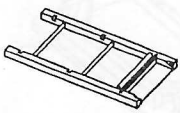
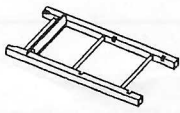
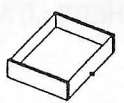
ASSEMBLE ON A FLAT, PROTECTED SURFACE

PART LIST	FIGURE	QUANTITY	DESCRIPTION
A		1 PC	TABLE TOP
B		1 PC	FRONT LEG
C		1 PC	BACK LEG
D		1 PC	CROSS BAR
E		1 PC	LEFT SIDE FRAME
F		1 PC	MIDDLE FRAME
G		1 PC	DRAWER
H		2 PCS	SHELF
I		8 PCS + 1PC	BOLT
J		8 PCS + 1PC	SPRING WASHER
K		8 PCS + 1PC	FLAT WASHER
L		1 PC	ALLEN WRENCH
M		8 PCS + 1PC	SCREW

MADE IN VIETNAM

STEP 1

- A. PLACE TOP (A) UPSIDE DOWN ON A FLAT, PROTECTED SURFACE.
- B. ATTACH FRONT LEG (B) AND BACK LEG (D) TO TABLE TOP (A) AND CROSS BAR (D) AS SHOWN.
- C. USE ALLEN WRENCH (L) TO TIGHTEN BOLTS (I), SPRING WASHERS (J) AND FLASH WASHERS (K) AS SHOWN.

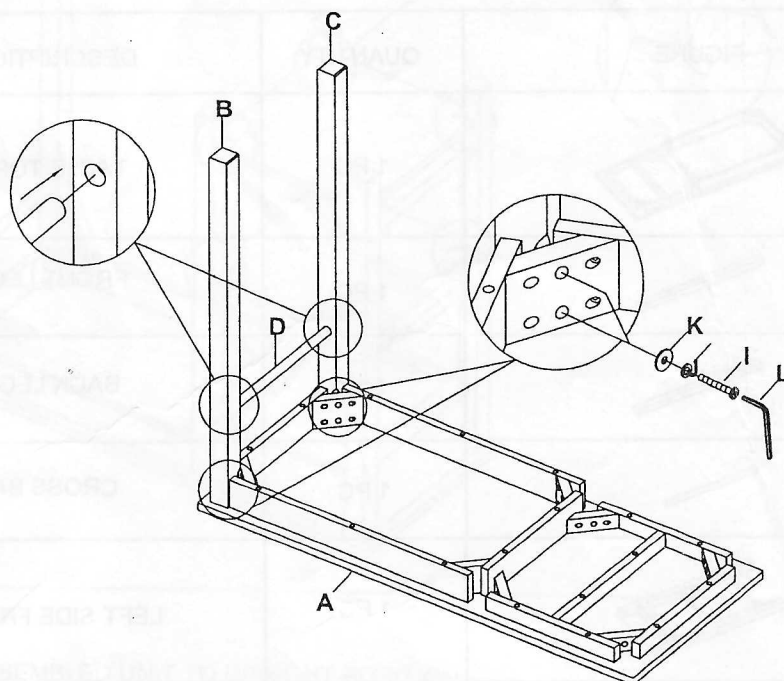

STEP 2

- A. ATTACH MIDDLE FRAME (F) TO TOP (A) WITH BOLTS (I), SPRING WASHERS (J) AND FLAT WASHERS (K) USING ALLEN WRENCH (L).

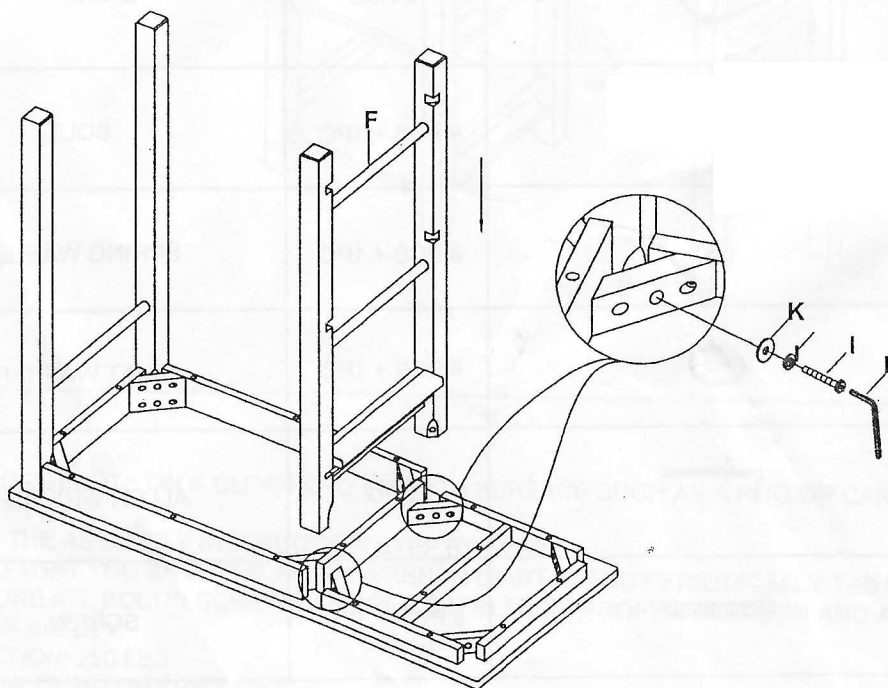

STEP 3

A. ATTACHED SHELVES (H) AND DRAWER (G) TO THE ASSEMBLED UNIT.

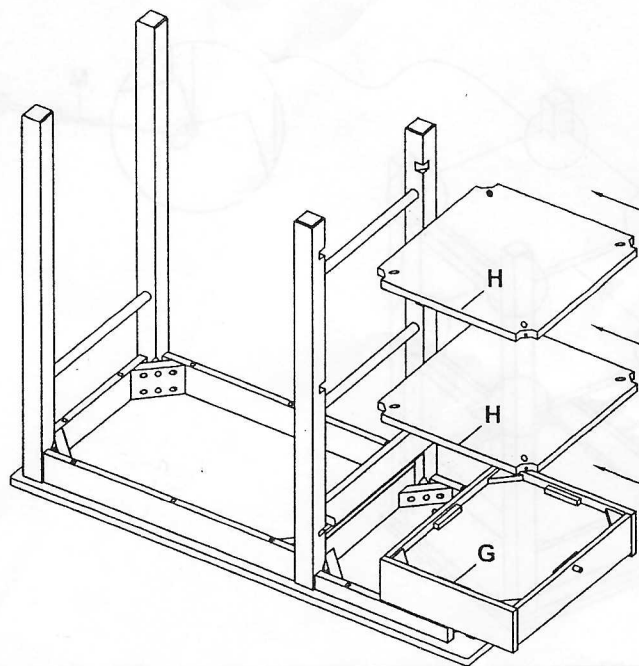

STEP 4

A. ATTACH LEFT SIDE FRAME (E) TO THE ASSEMBLED UNIT BY USING BOLTS (I), SPRING WASHERS (J) AND FLAT WASHERS (K). THEN TIGHTEN WITH ALLEN WRENCH (L).

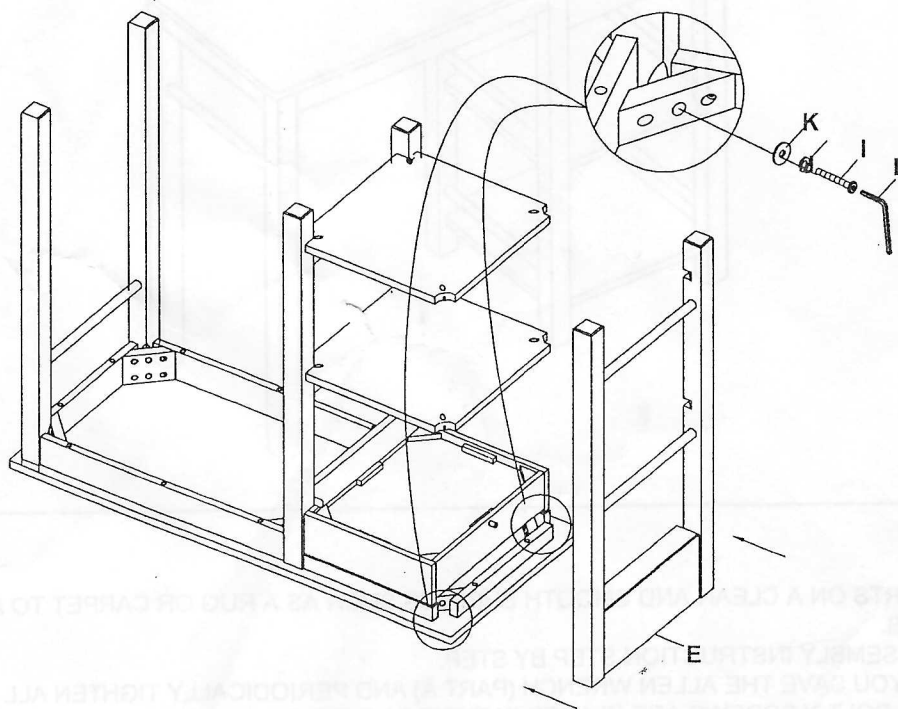

STEP 5

A. USE SCREW DRIVER (NOT PROVIDED) TO TIGHTEN SCREWS (M) AS SHOWN.

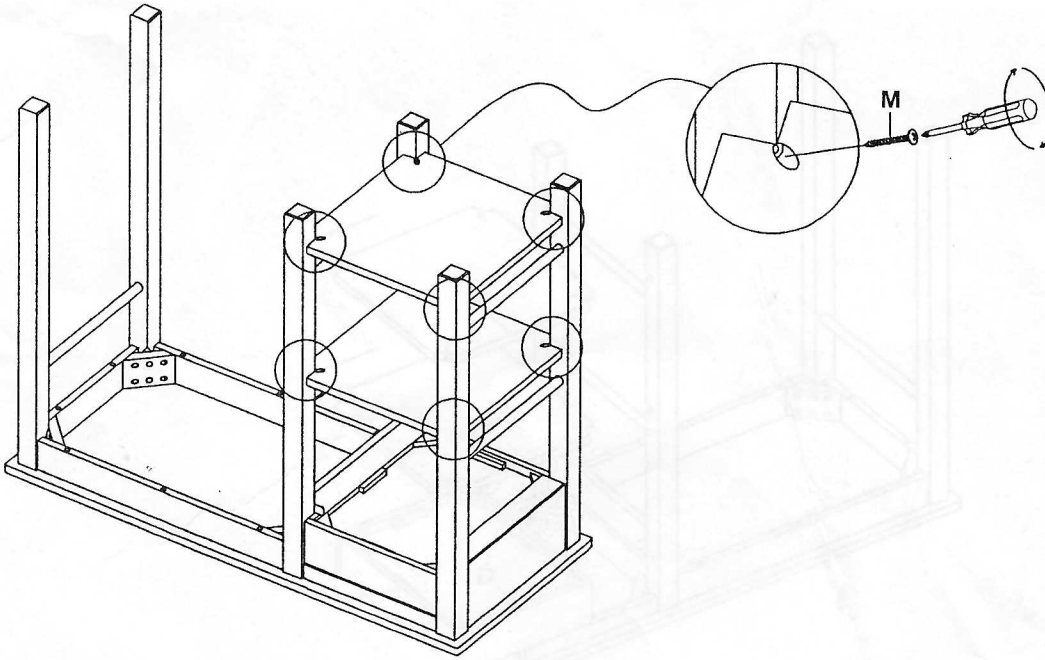

STEP 6

A. ROTATE THE ASSEMBLED UNIT TO UPRIGHT POSITION.
B. TABLE IS READY FOR USE.

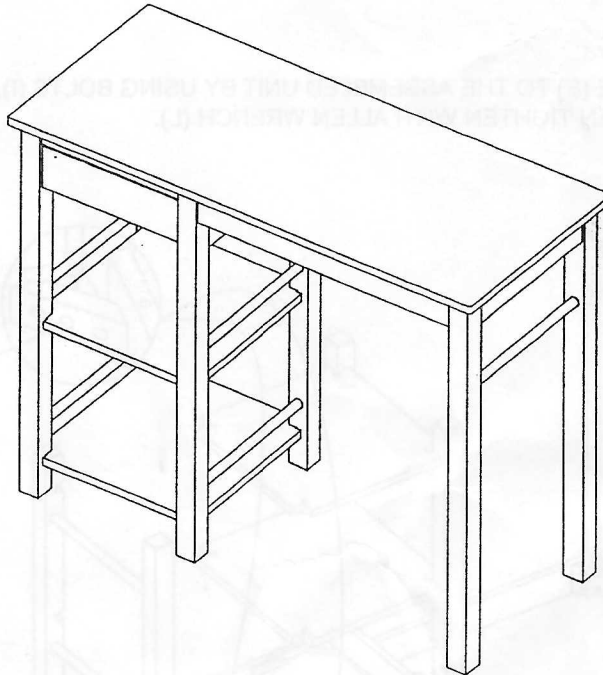

IMPORTANT NOTE:

- *** PLACE ALL WOODEN PARTS ON A CLEAN AND SMOOTH SURFACE SUCH AS A RUG OR CARPET TO AVOID SCRATCHING THE PARTS.
- *** KINDLY FOLLOW THE ASSEMBLY INSTRUCTION STEP BY STEP.
- *** WE RECOMMEND THAT YOU SAVE THE ALLEN WRENCH (PART A) AND PERIODICALLY TIGHTEN ALL BOLTS/SCREWS. PLEASE MAKE SURE ALL BOLTS/ SCREWS ARE PLACED IN THEIR PROPER POSITION AND ARE TIGHTENED SECURELY TO ENSURE YOUR SAFETY.
- ***WEIGHT RESTRICTION: 250 LBS
- *** DO NOT STAND OR CLIMB ON THE TABLE.
- *** NOT FOR COMMERCIAL USE.