

KEROSENE HEATER OWNER'S

MANUAL

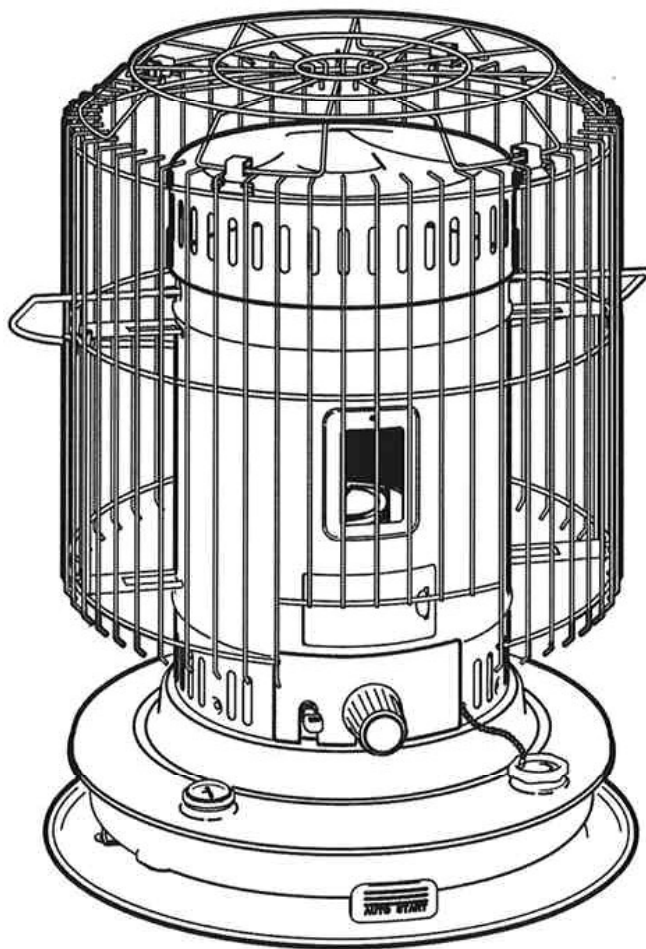

MODEL Mega-23K, CV-23K, HMC-23K



SENGOKU L.A., LTD.

TORRANCE, CA 90503

877-GET-HEAT

877-438-4328

www.SengokuLA.com

WARNINGS & CAUTIONS

1. WARNING:

FAILURE TO INSTALL, MAINTAIN, AND/OR OPERATE THIS KEROSENE HEATER ACCORDING TO MANUFACTURER'S INSTRUCTIONS MAY RESULT IN CONDITIONS WHICH CAN PRODUCE BODILY INJURY AND/OR PROPERTY DAMAGE.

NOTE: The **WARNING** and **IMPORTANT** Instructions appearing in this manual are not meant to cover all possible conditions and situations that may occur. It must be understood that common sense, caution, and carefulness are factors which cannot be built into this heater. These factors must be supplied by the person(s) installing, maintaining, or operating the kerosene heater.

Always contact your dealer, distributor, service agent, or the manufacturer on any problems or conditions you do not understand.

2. WARNING: RISK OF EXPLOSION

- * **NEVER** use any fuel other than clear or red dyed No. 1-K kerosene. **NEVER** use fuel such as gasoline, benzene, paint thinners or other oil compounds in this heater.
- * **NEVER** refill heater fuel tank when heater is operating or still hot.
- * **NEVER** use heater in areas where flammable vapors or gases may be present.
- * **NEVER** fill heater fuel tank in living space; fill tank outdoors.
- * **NEVER** store nor transport kerosene in other than a metal or plastic container that is (1) acceptable for kerosene, (2) non-red in color, and (3) clearly marked "Kerosene." **NEVER** store kerosene in the living space; kerosene should be stored in a well ventilated place outside the living area.
- * The unit is **EXTREMELY HOT** while in operation. Due to high surface temperatures, keep children, clothing, furniture, and other combustible objects at least 36" away from top and front area.
- * **RISK OF INDOOR AIR POLLUTION**
USE HEATER ONLY IN WELL VENTILATED AREAS. People with breathing problems should consult a physician before using the heater. In a house of typical construction, that is, one that is not of unusually tight construction due to heavy

insulation and tight seals against air infiltration, an adequate supply of air for combustion and ventilation is provided through infiltration; however, if the heater is used in a small room where less than 200 cubic feet (5.7 m³) of air space is provided for each 1,000 BTU per hour of heater rating (considering the maximum burner adjustment), the door(s) to adjacent room(s) should be kept open or the window to the outside should be opened at least 1 inch (25.4 mm) to guard against potential buildup of indoor air pollution. Do **NOT** use the heater in a bathroom or any other small room with the door closed.

- * **NEVER** use heater to heat or boil water nor use as a cooking appliance.

3. WARNING: RISK OF FIRE

NEVER use gasoline in this heater.

4. **NEVER** leave heater operating if you intend to leave for any period of time. Always make sure to turn heater off and inspect to insure that it is completely extinguished prior to going to bed.

5. **NEVER** leave heater unattended. **NEVER** use as a source of heat for drying objects.

6. **NEVER** place objects on the top plate.

7. If poor quality kerosene is used, so much carbon will be accumulated on the upper part of the wick that it may not move down, a strong odor will be generated and shorter wick life will result; therefore, careful attention should be paid to the kerosene quality. When lowering the wick, make certain fire is out. (For details, see Extinguishing on page 6.)

8. Adjustment of room temperature, when the room becomes too hot, should be carried out by ventilation such as opening a window, but never by means of the wick adjuster knob. If heat is reduced excessively by means of the wick adjuster knob, it will cause imperfect combustion, thereby resulting in accumulation of carbon, and odor will be generated.

9. CAUTION: RISK OF BURNS

NEVER operate the heater without the guard or grille completely attached.

SAVE THESE INSTRUCTIONS

TABLE OF CONTENTS

	Page		Page
Cautions	1	Carbon Removal	7
Introduction	2	Wick Replacement	8
Operating Controls/Features	2	Igniter Replacement	9
Specifications	2	Wick Raising Mechanism	10
Unpacking and Assembly	3	Long Term Storage	11
Fueling	4	Trouble Shooting Guide	12
Ignition	5	Exploded Parts Drawing	13
Wick Adjustment	5	Parts List	14
Extinguishing the Heater	6	Kerosene	15
Wick Maintenance	7		

I. INTRODUCTION

Please read this Instruction Manual carefully. It will show you how to assemble, maintain, and operate the heater safely and efficiently to obtain full benefit from its many built-in features.

FEATURES

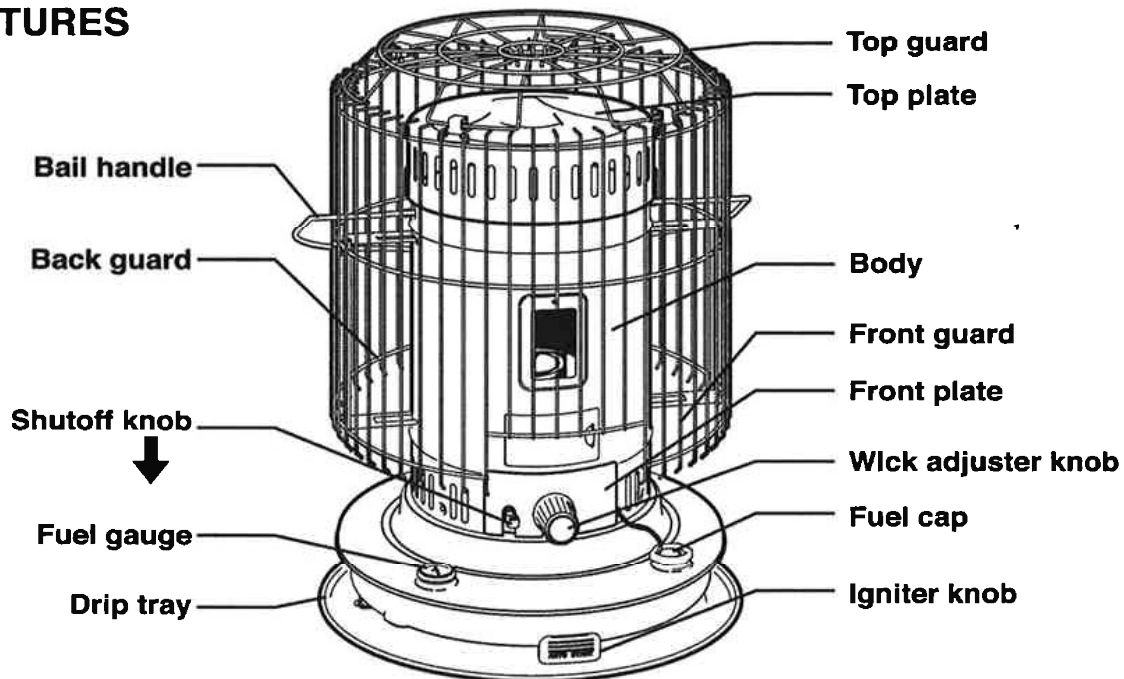

SPECIFICATIONS

Model No.	Mega-23K, CV-23K, HMC-23K		
Type of Heater	Convection	Weight (empty)	24.3 lbs. ※
Heat Output	Max. 23,000 BTU/hr.	Dimensions	Height 25 1/2 inches
Fuel Tank	Integral		Width 18 1/8 inches
Tank Capacity	1.9 U.S. Gallons		Depth 18 1/8 inches
Continuous Combustion Time	9-12 hr.	Max. Wick Height	25/64 IN. (10 mm)
Max. Fuel Consumption	0.167 U.S. gallon/hr.	Wick No.	OS-0023
Ignition Method	Battery—C Cell x 2	U.L. Listed	Yes

II. UNPACKING AND ASSEMBLY

Remove the heater and all packing materials from the box.(see fig.1)

Take time to locate each of these items:

Take time to locate each of these items:

- Heater (1)
- Drip Tray (2)
- Top Grill (3)
- Top Plate (4)
- 2 "C" Cell Batteries (5)
- Siphon Pump (6)
- Owner's Manual (7)
- Safety Tips Manual (8)

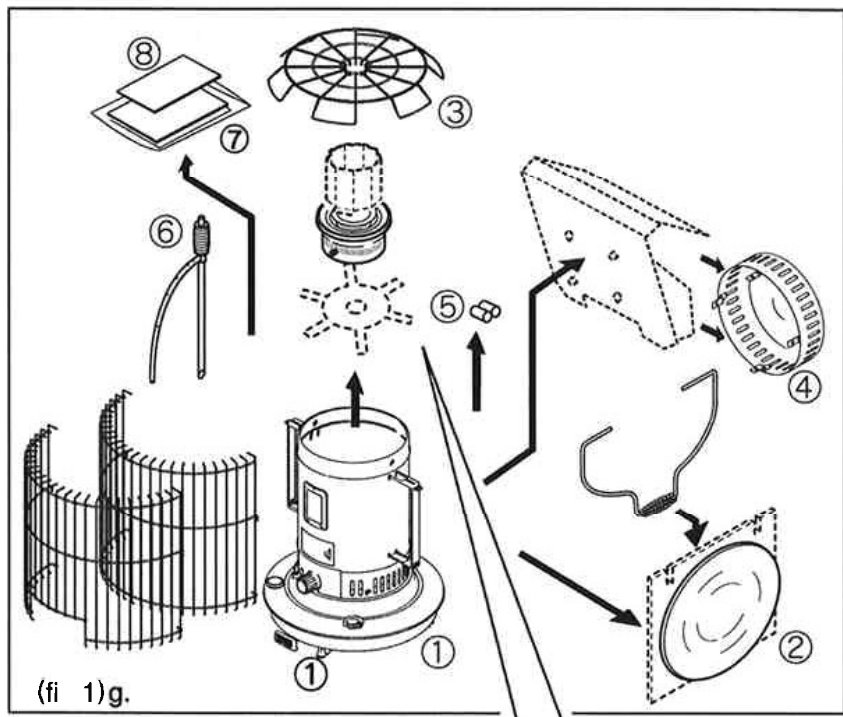

Now, reach inside the body of the heater, remove all of the packing, and take out the burn chamber. After locating each of these items, replace the styrofoam and all other packing materials in the box. **Save the box for summer storage.**

Place the heater on the drip tray and lock in position by turning clockwise.(see fig.2)

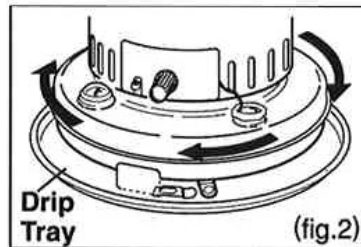

The grill assembly consists of three parts:(see fig.3)

- The top grill:



- The front grill and back grill, which are shipped front of the heater body.

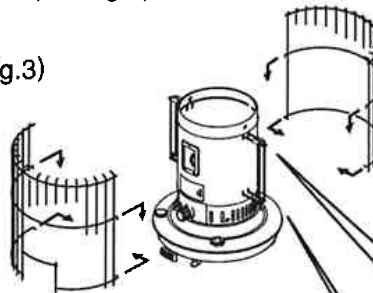

Raise the back grill and insert the mounting wire in the upper slot, both top and bottom.

Now, repeat this procedure with the front grill on the opposite side of the heater.

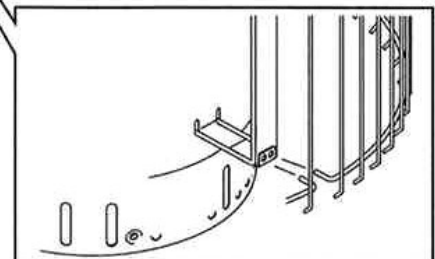
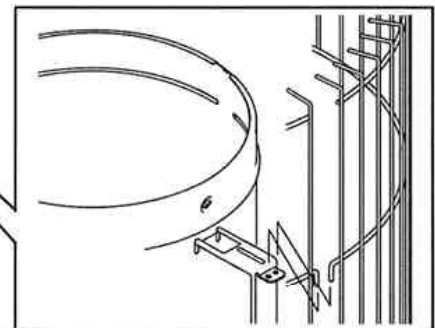
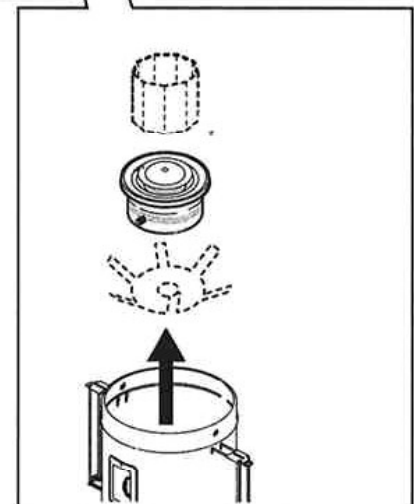

NEVER LEAVE THE HEATER UNATTENDED WHILE BURNING!

Set the burner into the body and make sure to follow the instructions on the burner, "This side up". Locate the wire adjusting handle on the burner so that it can be reached when the door is open. (see fig.4)

Place the top plate on the heater, so the holes on the attached brackets are aligned to mount the bail handle as described below. (see fig.5)

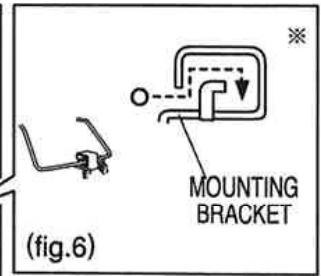
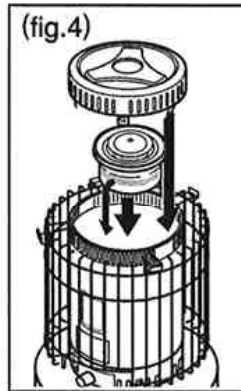

Attach the top grill to the four metal mounting brackets. (see fig.6)

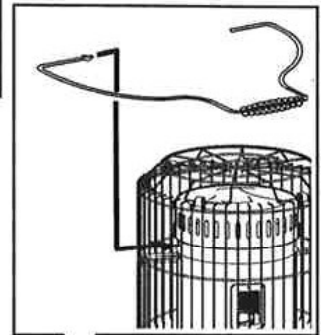

Mount the bail handle by holding it on the top of the heater, pulling it apart (it will spring back when installed), rotating the handle until it is flat to the ground, then allow it to snap through the holes in the body on the right and left side. The bail handle is designed to secure the top plate in place as well as provide an easy means to carry the heater. (see fig.7)

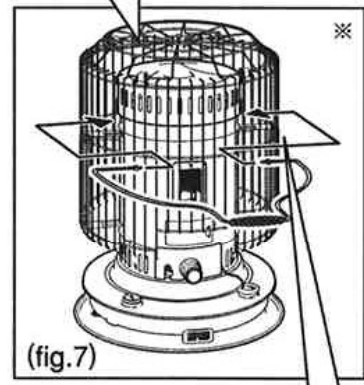

Install the 2 "D" batteries in the battery case on the back of the heater following the + and - signs.

Open the front door of the body and rotate the burner from side to side using the burner knob. Raise the wick to the full "up" position. Use the knob to lift the burner so that you can test the manual shutoff to make certain that the wick drops out of sight.

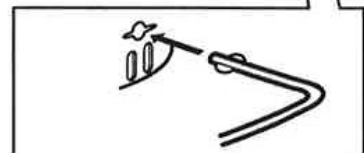

III. FUELING

Take the heater, kerosene, and siphon pump outdoors for fueling. Tighten the air-tight cap located on the top of the siphon; insert the straight tube into the kerosene container, place the flexible hose through the opening of the fuel tank. Squeeze the bulb rapidly, which will lift fuel from the kerosene container into the heater tank. (see fig.8&9)

Watch the fuel gauge on the base of the heater to determine the amount of kerosene transferred from container to heater. When you approach the full mark, loosen the airtight cap on the siphon, which will stop the flow of kerosene.

Allow the siphon to drain before removing it from the tank and the container. Replace the tank cap and the kerosene container cap securely. Thoroughly wipe up any spilled kerosene.

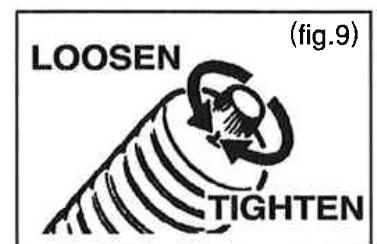
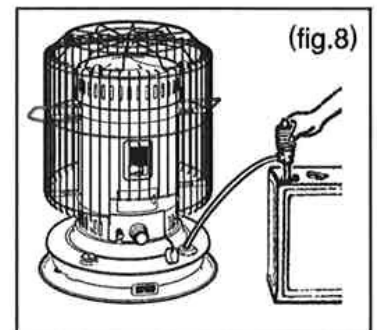

VERY IMPORTANT: Allow a minimum of 60 minutes (use a timer) for kerosene to completely saturate the wick and eliminate any air pockets which might otherwise occur before lighting the heater for the first time.

IV. AUTOMATIC IGNITION SYSTEM

The first time the heater is lit, it should be done outdoors to allow residues of oils and waxes used in manufacturing the heater and the wick to burn off. This will eliminate any odors from this initial light up from collecting inside the home.

The heater has been designed to be lit by using the automatic ignition system. This system consists of 2 "D" cell batteries, connecting wires, a manual arm which holds the igniter itself and which, when pushed, raises the burner and brings the igniter in contact with the wick after the wick has been raised to its maximum height.

The ignition sequence is as follows: Open the door below the mica window. Push in the auto start knob, The burner will be lifted up and the igniter coil will appear and begin to glow. Hold the auto start knob in and turn the wick adjuster knob clockwise to raise the wick. As the wick approaches the glowing igniter ignition will occur. As soon as flames are observed through the open door, release the igniter knob which will lower the burn chamber back down over the wick. It is important to rotate the burner knob left and right, back and forth, a few times to insure that the burner is properly located on the wick adjuster.

(see fig.10&11)

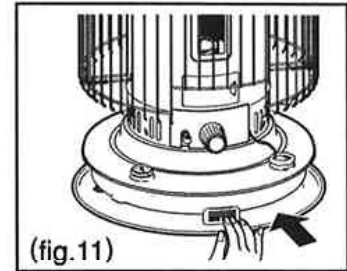
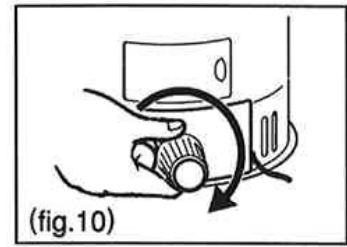

IGNITION BY MATCH

Should you experience difficulty with the igniter mechanism or dead batteries, the heater can be lit using a match. This is done by raising the wick, lifting the burner using the burner knob, and applying a lighted match to the exposed top edge of the wick.(see fig.12)

CAUTION: Be sure to remove the match or any broken portions of it from the burner area. A match head left in place can cause misalignment of the burner which may result in incomplete burning, odor, soot, or fire.

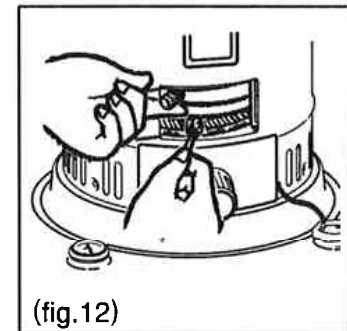

V. WICK ADJUSTMENT

Observe the heater flame during this initial light up. During the first 5 minutes, flames will gradually build up and appear at the top of the burner. As the burn chamber warms, the kerosene fuel will vaporize from the wick more easily. After 5-7 minutes, you will be able to use the wick adjuster knob to correctly position the flames at the top of the burner so that no more than 1/2" to 3/4" of flames appear, distributed evenly around the circumference of the flame spreader disk located in the center top of the burner. Four notches will appear in the flame where the crossbars in the burner deflect the air flow.

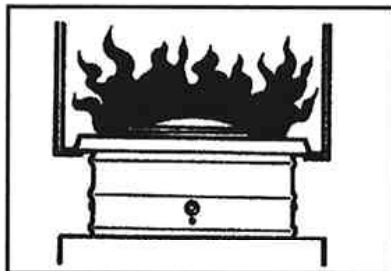

TOO HIGH
Produces smoke
and soot

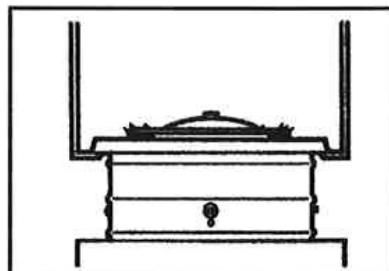

TOO LOW
Produces odor or
carbon monoxide

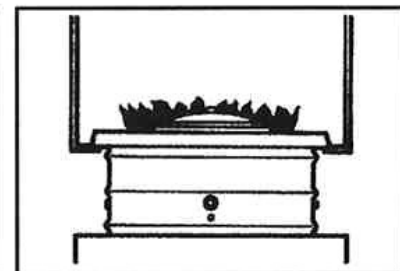

CORRECT
Most efficient
combustion

Because of changes in heater temperature and in room temperature, subsequent adjustments will be required after 60 minutes and periodically thereafter.

NOTE: The flames must be adjusted so that they are neither too high nor too low in order to obtain proper combustion. Basic adjustment of the flame is controlled by using the wick adjuster knob to raise or lower the wick. A fine adjustment of the flame can be made by grasping the burner knob and moving the burner from side to side and front to back until the bright yellow-white flames appearing at the top of the burner are as even as possible. After each adjustment, allow a few seconds time for the flames to stabilize.

IMPORTANT NOTE: During the burning period, heat which builds up inside the body of the heater will gradually warm first the burner, then the wick adjuster mechanism, and finally the kerosene located in the tank of the heater itself. As this warming occurs, more and more kerosene will vaporize which in turn may require further downward adjustment of the wick in order to maintain the flames at the 1/2" height above the burner. Because of this need for adjustment from time to time, **the heater should never be left unattended** and should be extinguished before going to bed or leaving your home.

Because the risk of fire and/or carbon monoxide poisoning, never attempt to save kerosene or reduce the amount of heat produced by your heater by operating it at a wick setting below the minimum Wick Stop setting, or showing less than 1/2" - 3/4" of flame around the circumference of the flame spreader disk.

VI. EXTINGUISHING THE HEATER

To extinguish, grasp the wick adjuster knob with one hand and push down the manual shutoff with the other hand. You will feel a strong spring tension attempting to rotate the wick adjuster knob counterclockwise and lower the wick. By relaxing your grasp slightly, allow the spring to gently lower the wick and extinguish the flames. When the spring action stops, confirm the wick has been fully lowered by turning the wick adjuster knob counterclockwise as far as possible. Allow 10-15 seconds, open the door on the body of the heater, lift the burner with the burner knob, and confirm that no flickering flames are present and the heater is fully extinguished .

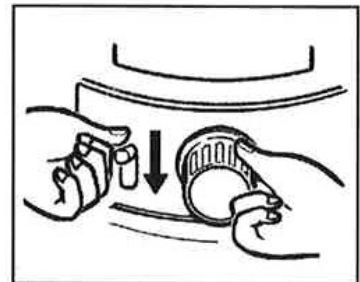

NOTE: Once the heater has been extinguished, wait 10 minutes before re-lighting. The 10-minute cooling off period allows the heater to return to normal condition and prevents the creation of a strong odor which will occur if an attempt is made to immediately relight an extinguished heater.

WARNING: After a period of use, tar and carbon may build up on the wick, interfering with its smooth lowering into the body of the heater. This could result in the flames not extinguishing completely. It is the owner's responsibility to inspect and maintain the wick to prevent such a hazard from occurring.

VII. WICK MAINTENANCE

VERY IMPORTANT !

The top of a fiberglass wick accumulates carbon in the process of burning kerosene. This must be removed to maintain peak efficiency in burning. It is most important that you feel for carbon hardness after the second or third tankful of fuel. A wick in good condition will feel soft while one that is carbonized will feel like a bristle brush or, in late stages, the top could be coated with hard black carbon.

Check for resistance when turning the wick adjuster knob; check if flame height is correct; check if it is difficult to ignite by the igniter. Any of these troubles result from carbon on the upper part of the wick. To get rid of carbon, perform the "Carbon Removal" in the following procedure.

VIII. CARBON REMOVAL/DRY BURNING

Carry out the "Carbon Removal" outdoors if windless, on a porch or the like, or in a room with its window(s) open because a strong odor is produced.

- (a) With the fuel tank having only a small amount of kerosene, keep the wick burning without refilling with kerosene even when the tank becomes empty. When the flame starts to burn out, raise wick fully and leave it there till it burns out. Wait approximately 60 minutes, then relight the wick with a match if necessary, and allow it to burn out again. When it cools, remove any remaining ash with an old toothbrush.

- (b) The upper part of the wick will be rid of carbon with this operation and be softened; however, if any parts are still stiff, pinch them by means of small pliers to fracture the carbon into pieces, supply a small amount kerosene to tank and once more perform the "Carbon Removal." After the carbon has been removed, refill tank and wait 60 minutes before igniting wick.

Carry out the "Carbon Removal" within 5 to 7 days after the first use of the kerosene heater. This will reduce carbon accumulation to the wick. Thereafter perform the "Carbon Removal" every 5 or 6 tank fulls of kerosene.

If any water gets into the tank or when the kerosene heater season comes to an end, completely remove all kerosene from the fuel tank. **VERY IMPORTANT!**

NOTE: "CARBON REMOVAL" SHOULD BE DONE WEEKLY DURING THE HEATING SEASON UNLESS NEEDED MORE FREQUENTLY. CHECK TO BE SURE.

IX. WICK REPLACEMENT

Wick replacement should be performed on a completely cool heater after the tank is empty and the remainder of the kerosene in the heater has been burned off.

- (1) Remove the batteries from the heater.
- (2) Remove top guard by unscrewing 2 screws.
- (3) Take off the top plate. Lift burner assembly out of heater.
- (4) Pull off the wick adjuster knob. Open the fuel cap. (fig.14)

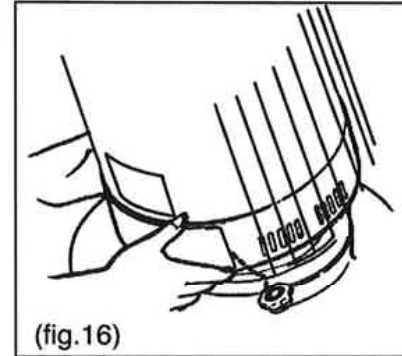
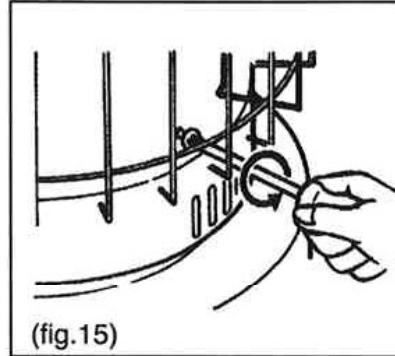
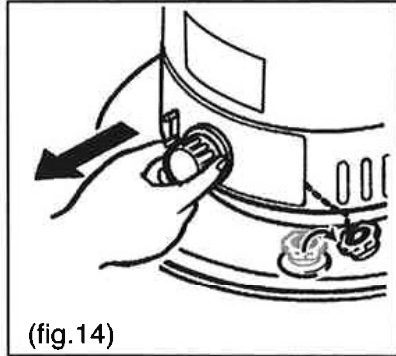

- (5) Unscrew 4 screws from the body and lift it off. (fig.15)
- (6) Lift off the body base. (fig.16)
- (7) Remove 3 screws securing the shelter plate and remove it.
- (8) Remove 4 wing nuts which hold the wick adjuster. (fig.17)
- (9) Lift out the entire assembly. To remove the wick from the adjuster, fold it and slide it out. Caution: the teeth holding the wick are very sharp.

- (10) The replacement wick has a black line.
- (11) Fold the new wick and slide it into the adjuster. The black line on the outside of the wick should match the bottom edge of the adjuster. Press the wick against the teeth inside the adjuster to obtain a firm grip. Start at the bottom row of teeth and slowly work your way up in a circular motion.

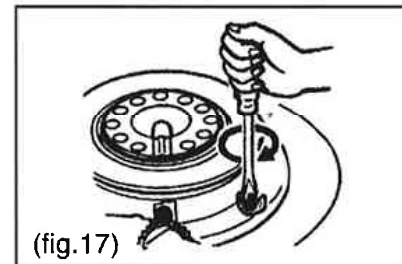

- (12) Check to see that the gasket is still in place on the burner tank.
- (13) Replace the wick and adjuster mechanism on the draft tube of the heater tank, making sure the wick fits evenly in place.
- (14) Slowly work the assembly down, making sure not to catch the threads in the unwoven section of the wick on the 4 wick adjuster mounting studs.
- (15) Position the adjuster shaft to the front of the heater.
- (16) Reinstall the wick adjusting knob.
- (17) Check the wick movement by rotating the knob clockwise and counter-clockwise. The wick should move up and down freely.
- (18) Snug but do not tighten 4 wing nuts on the mounting studs.
- (19) Raise the wick a little and check for correct clearance between wick holder and draft tube (all around).
- (20) Evenly tighten wing nuts in several steps.
- (21) Check height of wick, 3/8 inch above rim of wick adjuster.
- (22) Recheck for correct clearance using a 7/32 dia. drill bit.
- (23) Check the tipover switch by upsetting the pendulum and by pushing down the manual shut off lever.
- (24) Reinstall the shelter plate with 3 securing screws.
- (25) Remove the wick adjusting knob.
- (26) Reinstall the body base and replace the wick adjusting knob.
- (27) Turn wick adjuster knob clockwise as far as you can. Then push down the manual shut off. Wick should drop quickly to the lowest position possible.

- (28) Reinstall the heater body and tighten 4 screws.
- (29) Replace the burner into the body making sure to follow the instructions on the burner, "this side up".
- (30) Reinstall top plate.
- (31) Reinstall top guard and fasten 2 securing screws.

Install the batteries in the battery case. Fill with clean, pure 1-K kerosene. Wait at least 60 minutes for kerosene to fully saturate the new wick. **IMPORTANT!** If this is not done air bubbles may form in the wick reducing its ability to draw up kerosene. Remember to "dry burn" the new wick after each 5 or 6 tankfulls of kerosene are consumed.

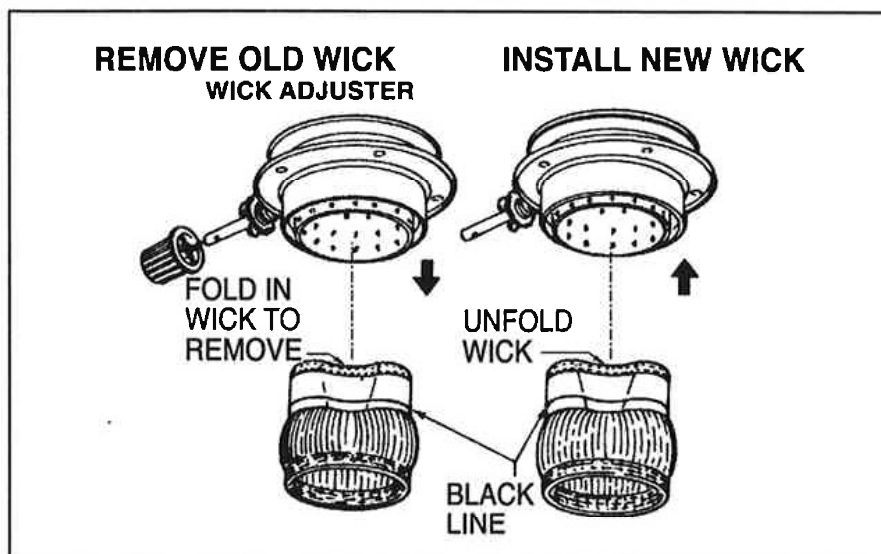

AFTER THE ASSEMBLY IS IN PLACE, ROTATE 90° LEFT AND RIGHT AS WELL AS UP AND DOWN UNTIL THE WICK SLIDES FREELY

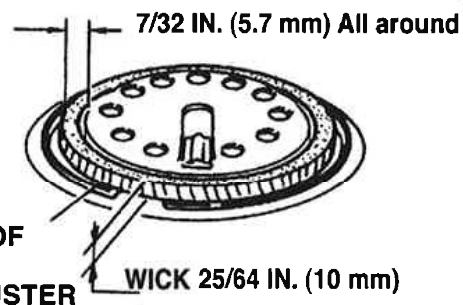
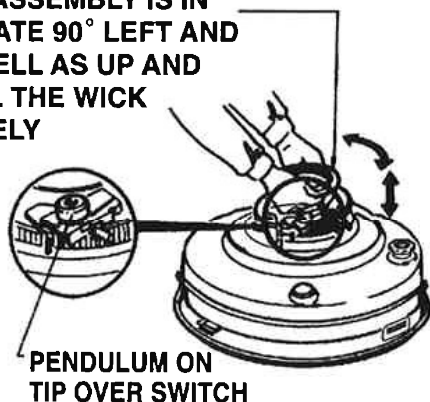

NOTE: Wick height is measured from top rim of the wick adjuster. The wick height should be 25/64 in. (10 mm).

X. IGNITER REPLACEMENT

Be sure igniter is 2.5V DC, 1A only.

- (A) Remove batteries from case.
- (B) Remove the top guard, top plate, body and burner.
- (C) Push the igniter knob. To remove the igniter, push in and turn counterclockwise. Install new igniter and reassemble the heater. Then install batteries.

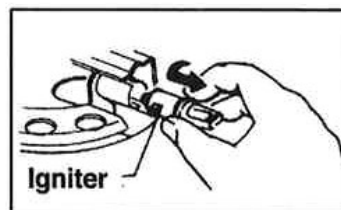

WICK-RAISING MECHANISM— CONVECTION TYPE

Rotating the wick control knob clockwise turns the pinion at the other end of the wick control shaft and causes the rack mounted along the outer circumference of the wick holder assembly to turn. This results in the wick being lifted to the top of the wick holder assembly. As the wick rises, the torsion spring mounted on the wick control shaft is put under tension and compressed. The wick can be contacted by the igniter when in the full "up" position. It is held there against the tension of the torsion spring by the latch that engages the ratchet mounted on the wick control shaft. Pressing the manual shutoff lever downward releases the latch, allowing the torsion spring to rapidly lower the wick. The descent of the wick can be slowed by lightly grasping the wick control knob. Lowering the wick slowly in this manner reduces the likelihood of a kerosene odor.

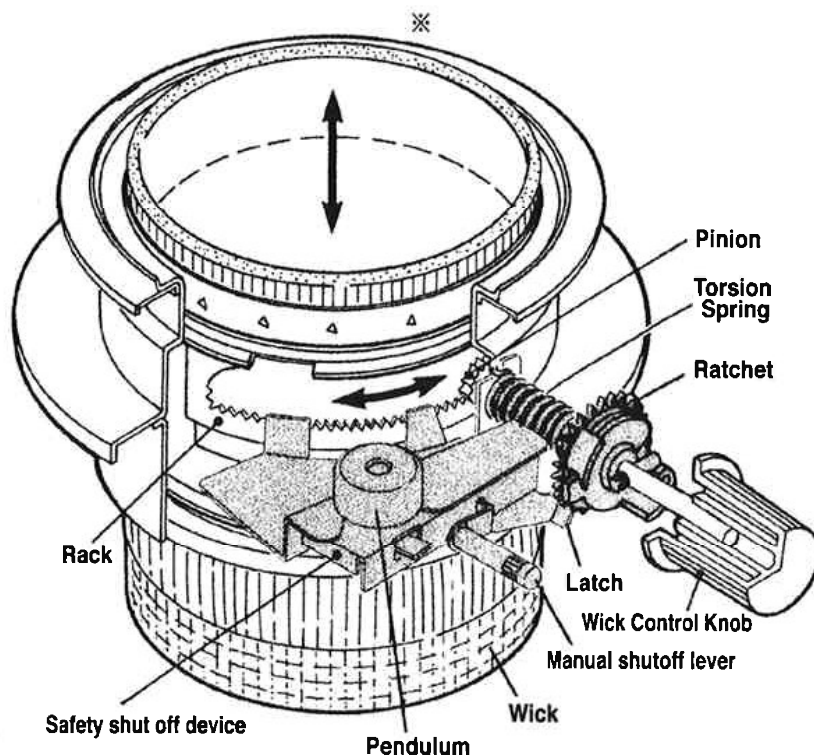

AUTOMATIC EXTINGUISHING MECHANISM

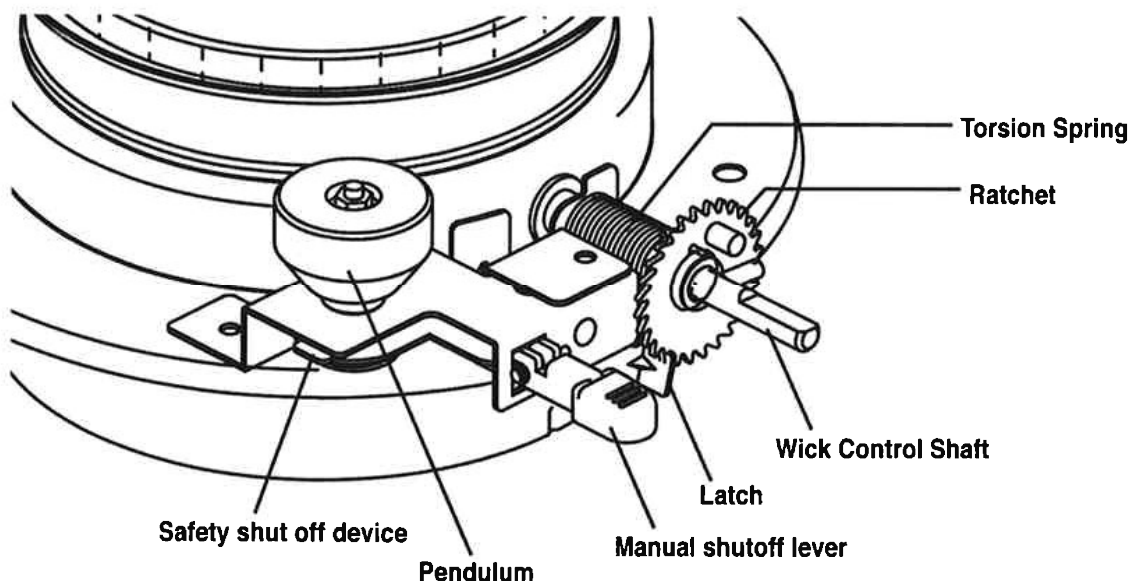

FUNCTION OF THE AUTOMATIC SAFETY SHUTOFF DEVICE

The safety shutoff device is built into the wick raising and lowering mechanism. It is a primary safety system in a kerosene heater. Its purpose is to prevent the spread of flame should a heater be accidentally tipped over while in use.

It functions in the following manner. When the pendulum starts to swing because of a shock, it causes the latch to be retracted from the wick control shaft ratchet. This permits the torsion spring to quickly retract the wick to the fully lowered position. The resulting quick drop puts out the flame.

IMPORTANT: For the automatic safety shutoff mechanism to function as intended, the wick must be free of gummy tar deposits. This can be accomplished by regularly "dry burning" the wick as described on page 7 under "Wick Maintenance" and "Carbon Removal / Dry Burning."

CAUTION

The operation of the automatic safety shutoff mechanism should be checked periodically, i.e., once a week during the heating season. This can be done by using the wick control knob to raise the wick to the fully upright position. **DO NOT LIGHT THE WICK FOR THIS TEST.** Grasp the upper corners of the protective grille and give the heater a firm shake. If the safety shutoff is working correctly, you will hear a loud snap as the latch disengages from the ratchet and the torsion spring quickly drops the wick. Now attempt to rotate the wick control knob counterclockwise. A correctly functioning automatic tipover device will lower the wick completely. If you are able to lower the wick further, this indicates it is time to "dry burn" for carbon and tar removal again.

NOTE: Every time the wick is removed and replaced, the safety shutoff must be tested to insure it is operating properly.

XI. LONG TERM STORAGE

Store the kerosene heater carefully using the following procedure so it will operate safely next season.

- (1) Agitate and rinse inner part of the tank with a little of the remaining kerosene, then pour out entirely. Water never mixes with kerosene, and it causes rust inside the tank. Remove all kerosene.
- (2) With the kerosene out of the fuel tank, ignite and keep the wick burning. Keep the wick fully turned up until it burns out (about an hour).
- (3) Detach the body, burner and batteries. Remove the wick adjuster from the fuel reservoir, dry the inside of the fuel tank thoroughly. Remove the carbon accumulated on the wick adjuster and/or the soot adhering to the burner with a brush or screw driver.
- (4) After cleaning, reassemble the heater. Remember to reassemble the wick adjuster so as to keep the gap between the wick adjuster and wick guide cylinder equal all the way around. Refer to page 8 "Wick Replacement."
- (5) The batteries should be taken out from the battery case because they may leak and corrode the kerosene heater.(see fig.22)
- (6) Store the kerosene heater with the tipover extinguishing device deactivated and the wick lowered down.
- (7) Put the kerosene heater in the original box with original packing (reassemble the guard) and keep it in a well-ventilated place. Also keep the Owner's Manual with heater.(see fig.23)

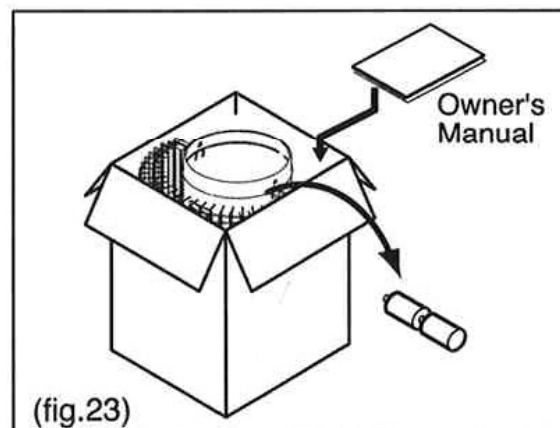
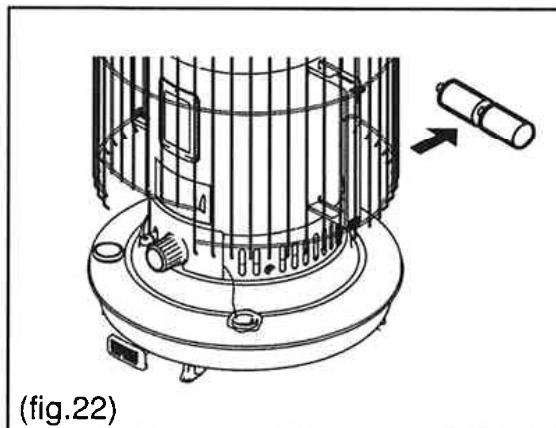

QUICK CURES FOR COMMON TROUBLES

Heater Won't Light

1. Water in kerosene
2. Empty tank
3. Igniter fails to glow brightly
4. Igniter coil contacts side of wick

Action to be Taken

Remove wick assembly and dry out wick on absorbent paper. Drain tank. Reinstall wick assembly. Fill with clean, pure kerosene (1-K Low Sulphur).
Fill with clean, pure kerosene (1-K Low Sulphur).
Check and replace batteries if necessary. Replace igniter coil, disconnected or broken wire.
Use the wick adjusting knob to lower wick until the igniter contacts top of wick

Flame Flickers or Dies

1. Water in kerosene
2. Wick covered with carbon or tar

Remove wick assembly and dry out wick on absorbent paper. Drain tank. Reinstall wick assembly. Fill with clean, pure kerosene (1-K Low Sulphur).
Burn wick clean. (In more serious cases, trim with scissors.)

Flame Smokes or Causes Odor

1. Flame too high
2. Air drafts hitting heater
3. Burner unit not level
4. Wick contaminated with carbon or tar
5. Impure kerosene

Use adjusting knob to lower wick.
Move out of direct drafts.
Use wire handle to rotate burner until it seats on ring encircling wick.
Burn wick clean. (In more serious cases, trim with scissors.)
Remove wick assembly and dry out wick on absorbent paper. Drain tank. Reinstall wick assembly. Fill with clean, pure kerosene (1-K Low Sulphur).

Excessive Wick Burning Down

1. Dangerous volatile fuel such as alcohol, gasoline, paint thinner, etc. mixed in kerosene.

Drain tank.
Replace wick.
Fill with clean, pure kerosene (1-K Low Sulphur).

Wick Adjuster Sticks

1. Water in kerosene
2. Carbon or tar buildup on wick

Remove wick assembly and dry out wick on absorbent paper. Drain tank. Reinstall wick assembly. Fill with clean, pure kerosene (1-K Low Sulphur).
Burn wick clean. (See page 7)

If the whole heater is enveloped in flames . . .

If possible smother flames with a fire extinguisher or sand. Otherwise, smother with blankets, then immediately throw water on the blankets. Do not throw water directly on the heater.

EXPLODED PARTS DRAWING

NOTE: SPECIFY MODEL NUMBER AND SERIAL NUMBER WHEN ORDERING PARTS.

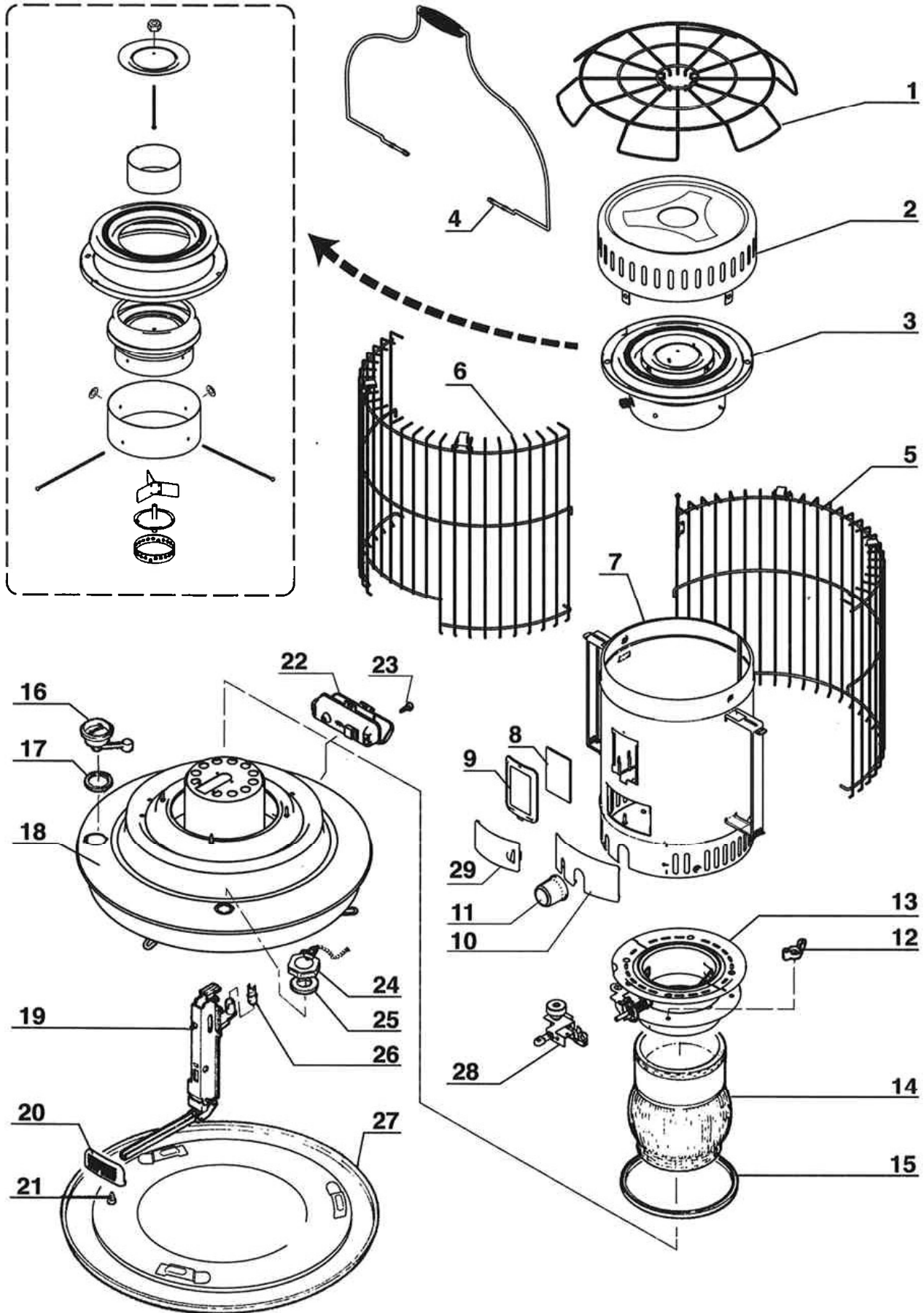

PARTS LIST

PICTURE REFERENCE NUMBER	DESCRIPTION	PART NUMBER
1	TOP GRILLE	OS-CVK01D
2	TOP PLATE	OS-CVK03A
3	BURNER ASS'Y	OS-CVK04B
4	BAIL HANDLE	OS-CVK05D
5	BACK GRILLE	OS-CVK06E
6	FRONT GRILLE	OS-CVK07E
7	BODY	OS-CVK08C
8	WINDOW	OS-CVK09
9	WINDOW SUPPORT	OS-CVK10
10	PANEL	OS-CVK13
11	KNOB	OS-CV14
12	WING NUT, WICK HOLDER	(M4)
13	WICK HOLDER ASS'Y	OS-CVK16
14	WICK	OS-0023
15	WICK CASING GASKET	OS-CV17
16	KEROSENE LEVEL GAUGE	OS-CV19A
17	RUBBER PACKING-(A)	OS-CV20
18	KEROSENE TANK ASS'Y	OS-CVK21
19	IGNITION ASS'Y	OS-CVK23
20	IGNITION KNOB	OS-CVK24
21	IGNITION KNOB SCREW	OS-CV25
22	BATTERY CASE ASS'Y	OS-CVK26A
23	TAPPING SCREW, BATTERY HOLDER	(M3x6)
24	FUEL CAP ASS'Y	OS-CVK27A
25	RUBBER PACKING-(B)	OS-CVK28
26	IGNITER COIL	OS-CV29
27	DRIP TRAY ASS'Y	OS-CVK30B
28	TIPOVER SWITCH	OS-CVK31
29	DOOR	OS-CVK33

KEROSENE

Locating and using proper kerosene is the single most important thing you, the owner, can do to insure your satisfaction in the use of the heater. The correct grade of kerosene will be labeled 1-K, which means it has been carefully refined to eliminate virtually all but the merest trace of sulphur. Sulphur causes the "rotten egg" smell. Kerosene containing sulphur will cause your heater to give off a disagreeable odor and make using it unpleasant.

All heaters will give off a slight odor on start up and turn down. This is normal, unavoidable, and to be expected. Some people are much more sensitive to this odor than others. Once your heater has reached its proper operating temperature (7-10 minutes) and is operating normally, there is no odor.

Kerosene may be purchased either crystal clear or dyed red. Kerosene deteriorates rapidly in storage, so fresh kerosene should be used at all times. Kerosene is easily contaminated by water which condenses in the fuel seller's tank. You can test kerosene for water by tilting your container and drawing four cups from the lowest part of the container into a clear glass jar. Let it sit for a few hours and then examine the bottom of the jar for little pin-heads (or BB's) which are actually water droplets. Water droplets will infiltrate your wick, but cannot pass through it. Instead, they block the flow of kerosene causing your heater to not burn properly.

If you buy kerosene in bulk, be certain to store it in a blue container. **NEVER** store kerosene in a red container which is the universal symbol for gasoline. **NEVER** attempt to use any other fuel such as gasoline, alcohol, white gas, or camping stove fuel in your kerosene heater. These fuels are very volatile and can cause uncontrolled flames.

Kerosene deteriorates with age and will not burn properly in the heater. It should be stored away from direct sunlight or other sources of heat. **NEVER** store kerosene in your living quarters.

A kerosene heater cannot function properly if the kerosene is contaminated with even a small amount of water. Water is frequently present in kerosene which is purchased from bulk storage. This water is due to condensation and comes out of the air which replaces kerosene when a large tank is emptied. For this reason, it is better to buy bulk kerosene from a dealer who dispenses it from a 55-gallon drum.

- First Choice: Prepackaged 1-K Kerosene**
- Second Choice: 55-Gallon Drum**
- Third Choice: Bulk Kerosene from a Large Tank (either stored in the ground or elevated above ground)**

For people who are sensitive to normal kerosene odors, or experience "fumes" during the operation of their heater, we recommend Clear Lite™ Synthetic Fuel manufactured by Exxon Chemical Co. It is completely odorless and is safer to store than kerosene.

When purchasing kerosene in bulk, you must rely on the reputation of your dealer. Even the best dealer can occasionally receive a "bad batch" from his fuel distributor.

Poor quality kerosene, kerosene contaminated with water or traces of other fuel oils, or kerosene with more than a very small trace of sulphur can cause: odor and smoke, low flame, difficulty in lighting or extinguishing the heater, excessive tar deposits on the wick, reduced wick life. If you experience any of the above, the first thing to do is check your kerosene. If there is any doubt as to its quality, dispose of it properly and retest your heater using a gallon of prepackaged kerosene.

Kerosene stored below 40°F will not vaporize easily and will not produce the expected amount of heat until it has warmed up in the tank of the heater in which it is being used. The best idea is to store the heater itself, or a tank full of kerosene, indoors if you intend to use your heater under severe winter conditions in a shed, garage, or ice-fishing house.

Kerosene in the USA is sometimes dyed red due to tax laws and the red dyed kerosene should be translucent (able to be seen through) and not cloudy.