

BED FRAME

offhandings.com

QUEEN/KING

ASSEMBLY INSTRUCTIONS

Before assembling your bed frame, please read through these instructions carefully and familiarize yourself with the different parts.



PARTS LIST

- ① FOOT RAIL 2 PCS
- ② LEFT LEG 2 PCS
- ③ RIGHT LEG 2 PCS
- ④ SIDE RAILS 2 PCS
- ⑤ SLAT KIT 2 SET
- ⑥ SUPPORT RAIL 2 PCS
- ⑦ SUPPORT LEG 2 PCS

HARDWARE

- ① JCB M6 X 70mm (2 3/4") - 4 pcs Spare - 1 pc
- ② Barrel nut - 4 pcs Spare - 1 pc
- ③ Wood dowel 10 X 30mm(1 1/8") - 8 pcs Spare - 1 pc
- ④ V Wood button - 4 pcs Spare - 1 pc
- ⑤ JCB M6 X 30mm (1 1/8") - 6 pcs Spare - 1 pc
- ⑥ Cap Nut - 6 pcs
- ⑦ JCB M8 X 40mm (1 5/8") - 2 pcs Spare - 1 pc
- ⑧ Wood screw(1 1/4") - 16 pcs Spare - 1 pc
- ⑨ 2pcs Split & Flat Washer
- ⑩ Allen wrench M4 - 1pc Spare - 1pc
- ⑪ Allen wrench M5 - 1pc

NOTE: WE INCLUDE SPARE HARDWARE IN CASE DAMAGE OCCURS DURING ASSEMBLY.

Step 1

Attach the legs (2) and (3) to foot rail (1), using wood dowel (C) JCB M6 X 70mm (A) and barrel nut (B). Tighten with the Allen wrench (J). Cover holes with V wood button (D) as shown. Repeat the other.

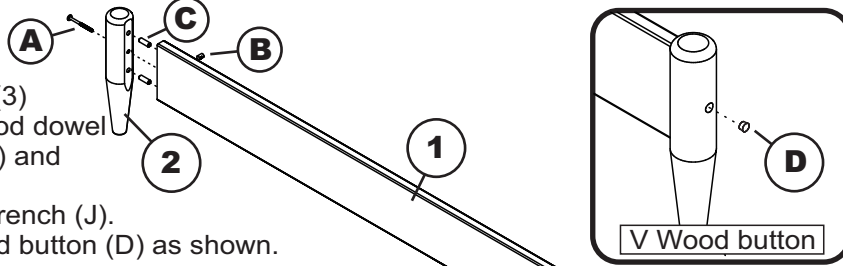

Step 2

Attach the side rails (4) to the headboard / footboard (1) using the bed hook as shown below.

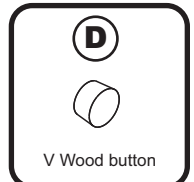
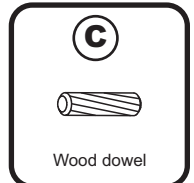
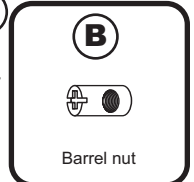
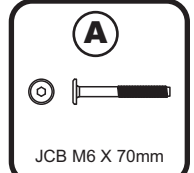
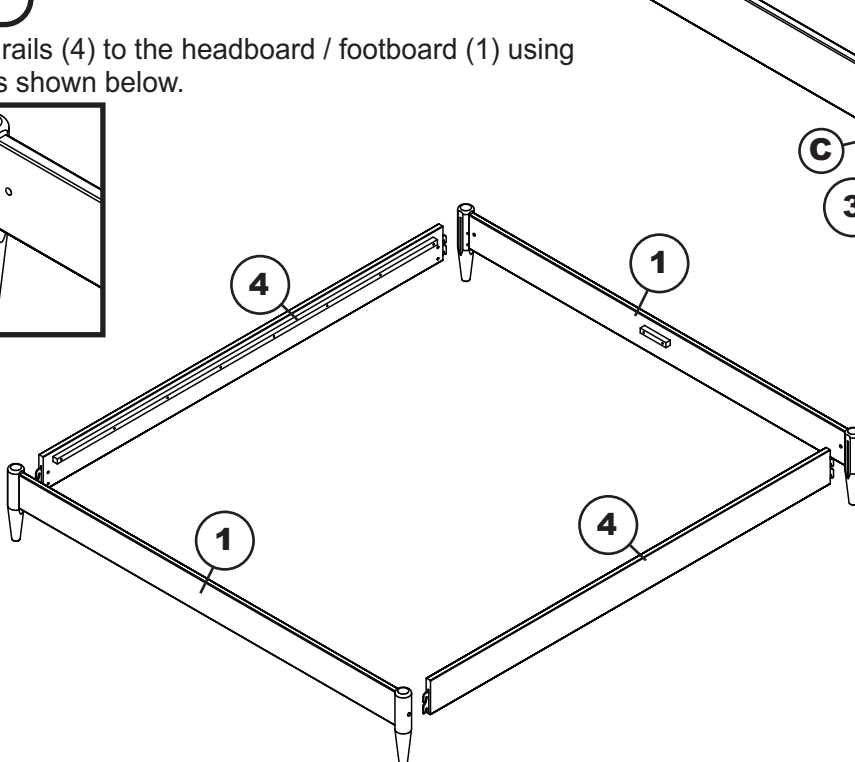
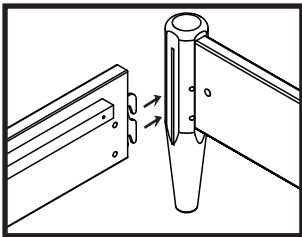

QUEEN/KING

Step 3

Attach support leg (7) to support rail (6) as shown below. Using JCB M8 (G) split and flat washer (I) tighten with Allen wrench M5 (K). Repeat the other.

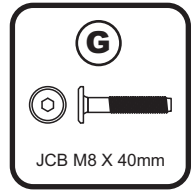
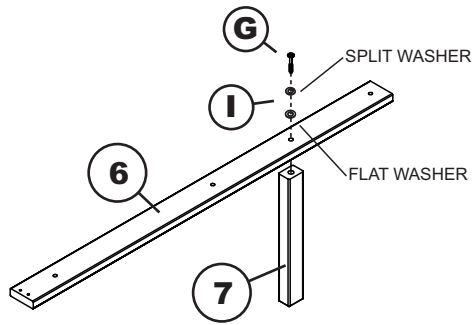

Step 4

Attach support rail (6) to the slat kit (5) as shown below using JCB M6 X 30mm (E) and cap nut (F). Tighten with Allen wrench M4 (J). Using wood screw (H) tighten with Phillips head screwdriver. (Customer supplied)

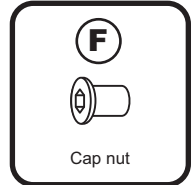
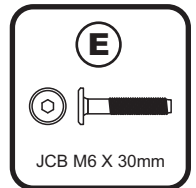
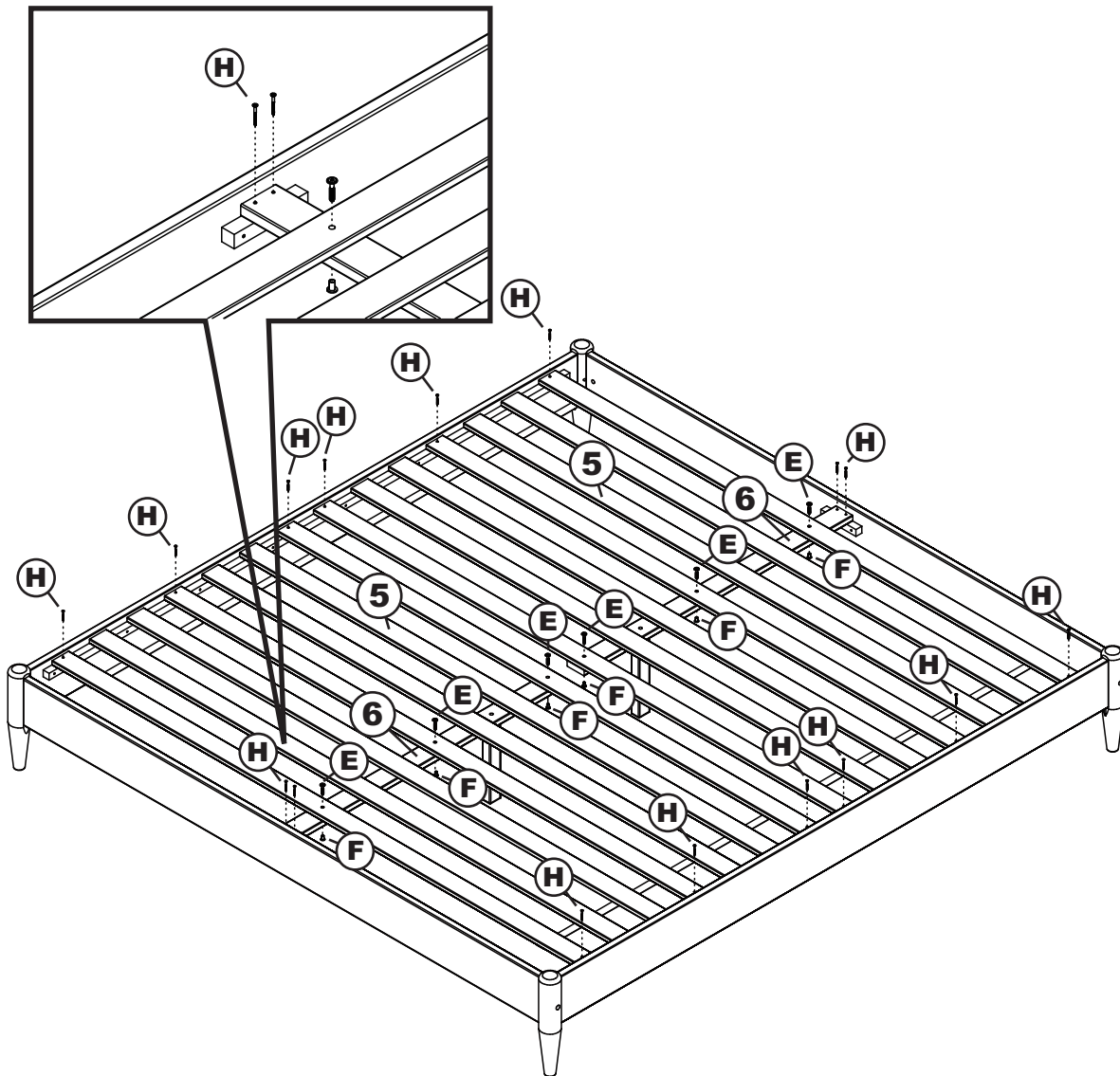

Congratulations!

Your bed is now ready for use.

We recommend that you periodically recheck that all screws are tight to ensure lasting safety.

HEADBOARD

ASSEMBLY INSTRUCTIONS

Before assembling your headboard, please read through these instructions carefully and familiarize yourself with the different parts.



PARTS LIST

- 1 HEADBOARD PANEL 1 PC
- 2 LEFT LEG 1 PC
- 3 RIGHT LEG 1 PC
- 4 PILLOW STOP 1 PC

Instructions apply for bed sizes
QUEEN > KING

HARDWARE

- A Wooden dowel - 4 pcs
Spare - 1 pc
- B JCB M6 X 40mm (1 1/2") - 6 pcs
Spare - 1 pc
- C JCB M6 X 110mm (4 3/8") - 2 pcs
Spare - 1 pc
- D Barrel Nut - 2 pcs
- E Allen wrench - 1 pc
Spare - 1 pc

HARDWARE FOR METAL BED FRAME

- F JCB M6 X 25mm (1") - 4 pcs
Spare - 1 pc
- G Flat washer - 4 pcs
Spare - 1 pc
- H Split washer - 4 pcs
Spare - 1 pc

NOTE: WE INCLUDE SPARE HARDWARE IN CASE DAMAGE OCCURS DURING ASSEMBLY.

Step 1

Attach the legs (2) and (3) to pillow stop (4), using JCB (C) and barrel nut (D). Do not tighten at this step. Attach leg assembly to headboard panel (1), using wood dowels (A) and JCB (B). Tighten all with the Allen wrench (E).

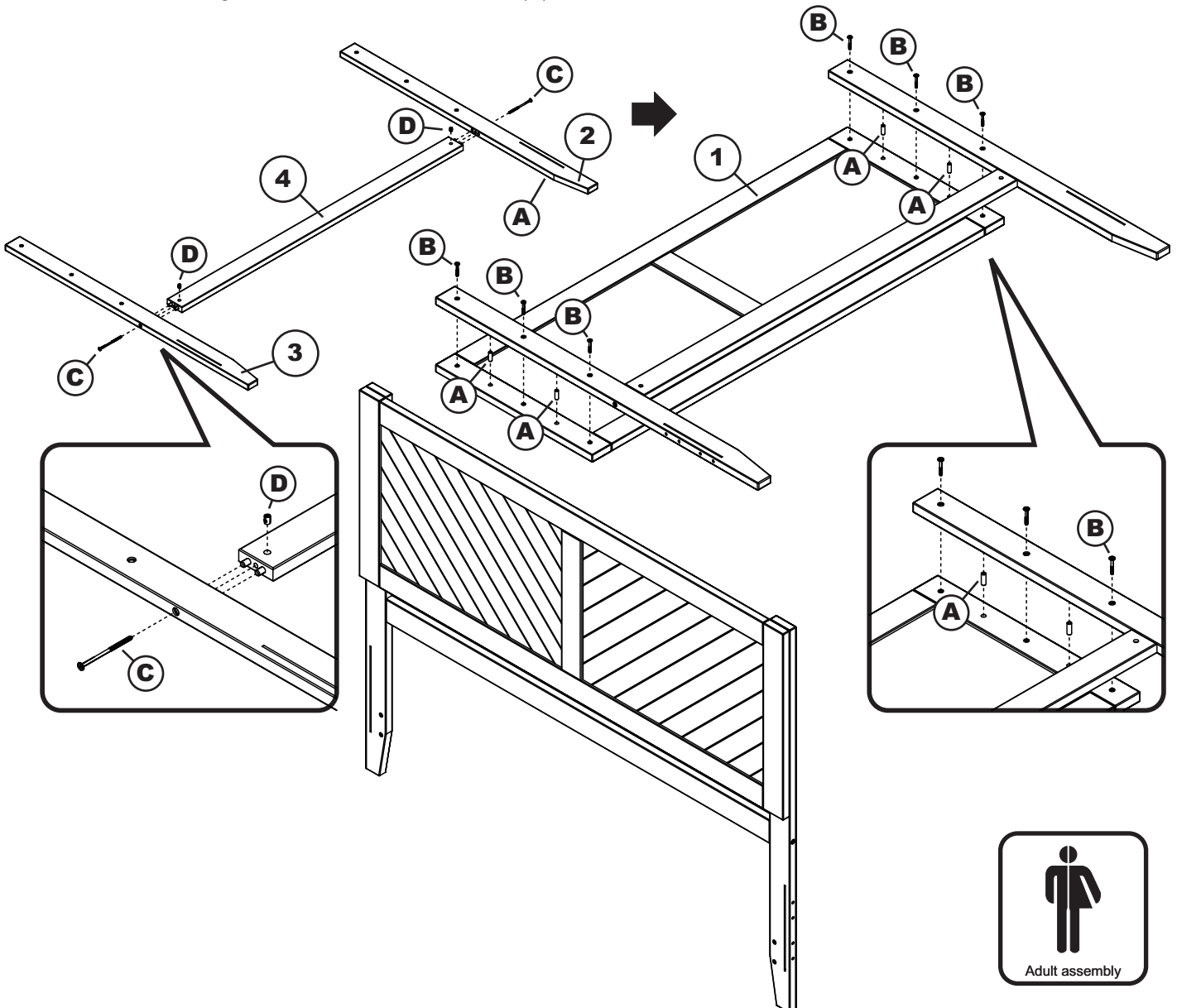

If you purchased a wood headboard to attach to metal bed frame, please refer to page 2.

ATTACHING HEADBOARD TO METAL BED FRAME

ASSEMBLY INSTRUCTIONS

Before assembling your bed, please read through these instructions carefully and familiarize yourself with the different parts.

Instructions apply for bed sizes
TWIN > FULL > QUEEN > KING



Adult assembly

Metal bed frames are sold separately from wood headboards. The hardware shown on this page is supplied with your wood headboard for attaching the bed frame to the headboard. The metal bed frame is supplied with its own assembly instructions and hardware.

Step 1

Attach the headboard assembly to the metal frame using JCB (F), flat washer (G), and split washer (H) then tighten with Allen wrench (E), as shown below.

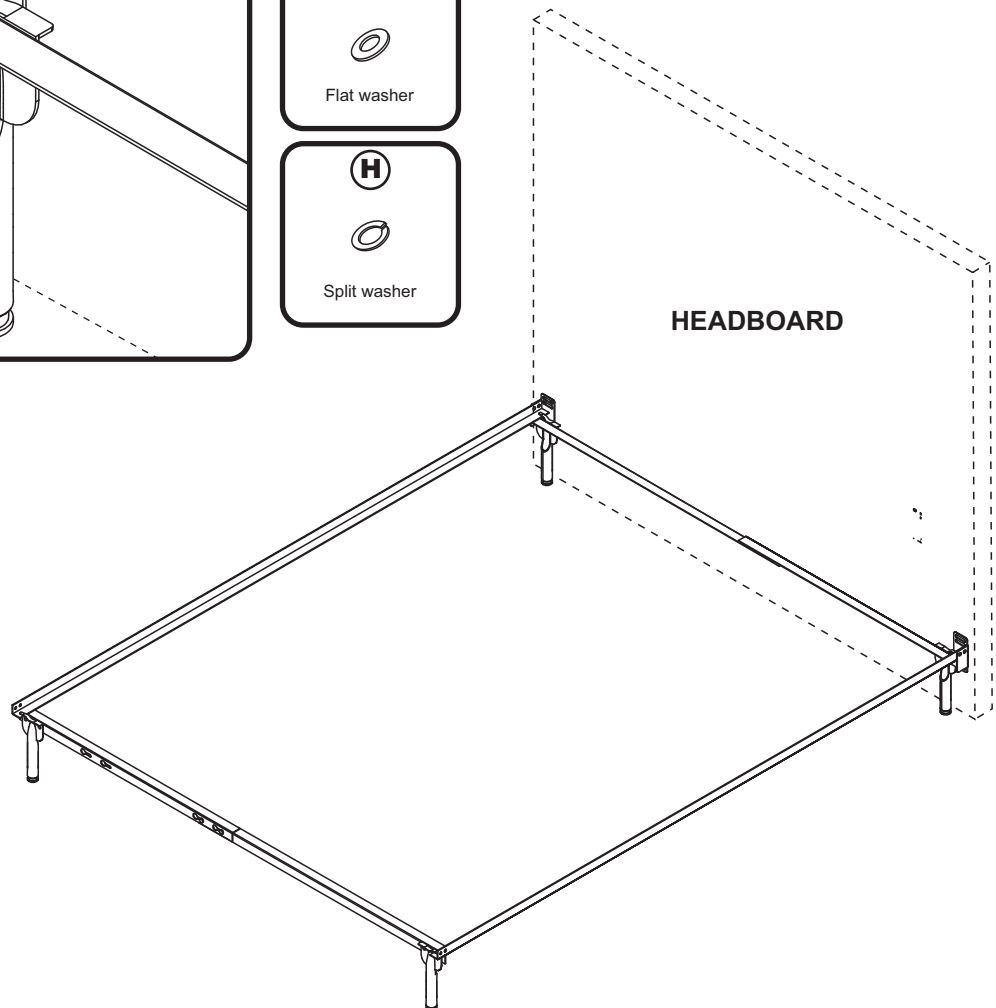
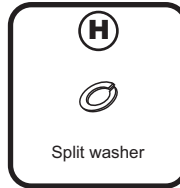
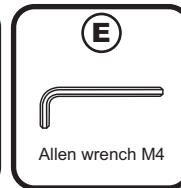
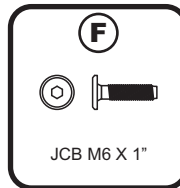
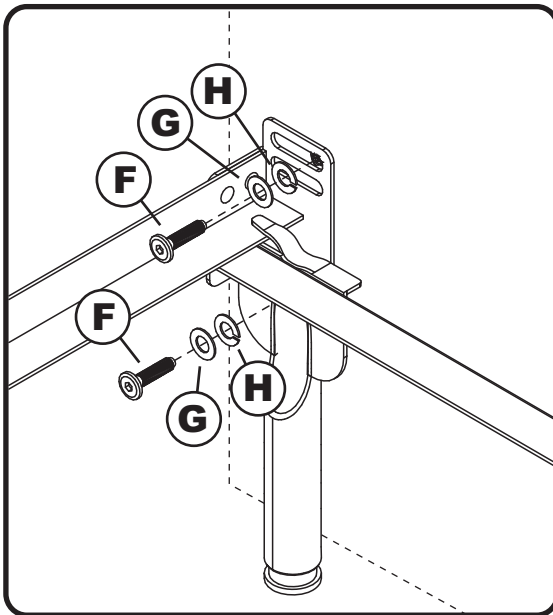

Congratulations!

Your bed is now ready for use.

To ensure lasting safety, we recommend that you periodically check that all screws are tight and all parts are secure.