

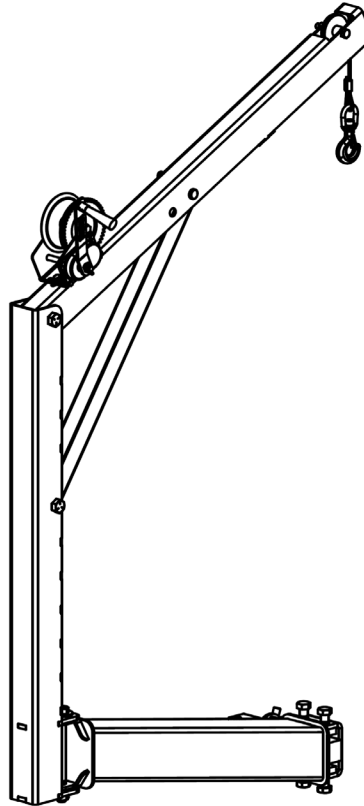

**Vestil Manufacturing Corp.**  
 2999 North Wayne Street, P.O. Box 507, Angola, IN 46703  
 Telephone: (260) 665-7586 -or- Toll Free (800) 348-0868  
 Fax: (260) 665-1339  
 Web: [www.vestilmfg.com](http://www.vestilmfg.com) e-mail: [info@vestil.com](mailto:info@vestil.com)

## Hitch-Mounted Jib Crane Model WTJ-HITCH Instruction Manual



**Receiving instructions:**

After delivery, remove the packaging from the product. Inspect the product closely to determine whether it sustained damage during transport. If damage is discovered, record a complete description of it on the bill of lading. If the product is undamaged, discard the packaging.

**NOTE:** The end-user is solely responsible for confirming that product design, use, and maintenance comply with laws, regulations, codes, and mandatory standards applied where the product is used.

**Technical Service Department (TSD) and Replacement Parts:**

For answers to questions not addressed in these instructions and to order replacement parts, labels, and accessories, call our Technical Service and Parts Department at (260) 665-7586. The department can also be contacted online at [http://www.vestilmfg.com/parts\\_info.htm](http://www.vestilmfg.com/parts_info.htm).

### Table of Contents

Specifications.....	2
Signal Words.....	2
Hazards.....	3
Labeling Diagram.....	3
Exploded View & Bill of Materials.....	4
Assembling the Crane.....	5, 6, 7
Post Angle Adjustments.....	7
Using the Crane.....	7, 8
Record of Normal Condition.....	8
Inspections & Maintenance.....	8
Limited Warranty.....	9

**Specifications:**

Dimensions, net weight, and capacity information appear in the diagrams and table below.

Side and Front Views: Brace connected to boom at either position A or B (see "Step 5" on p. 6)

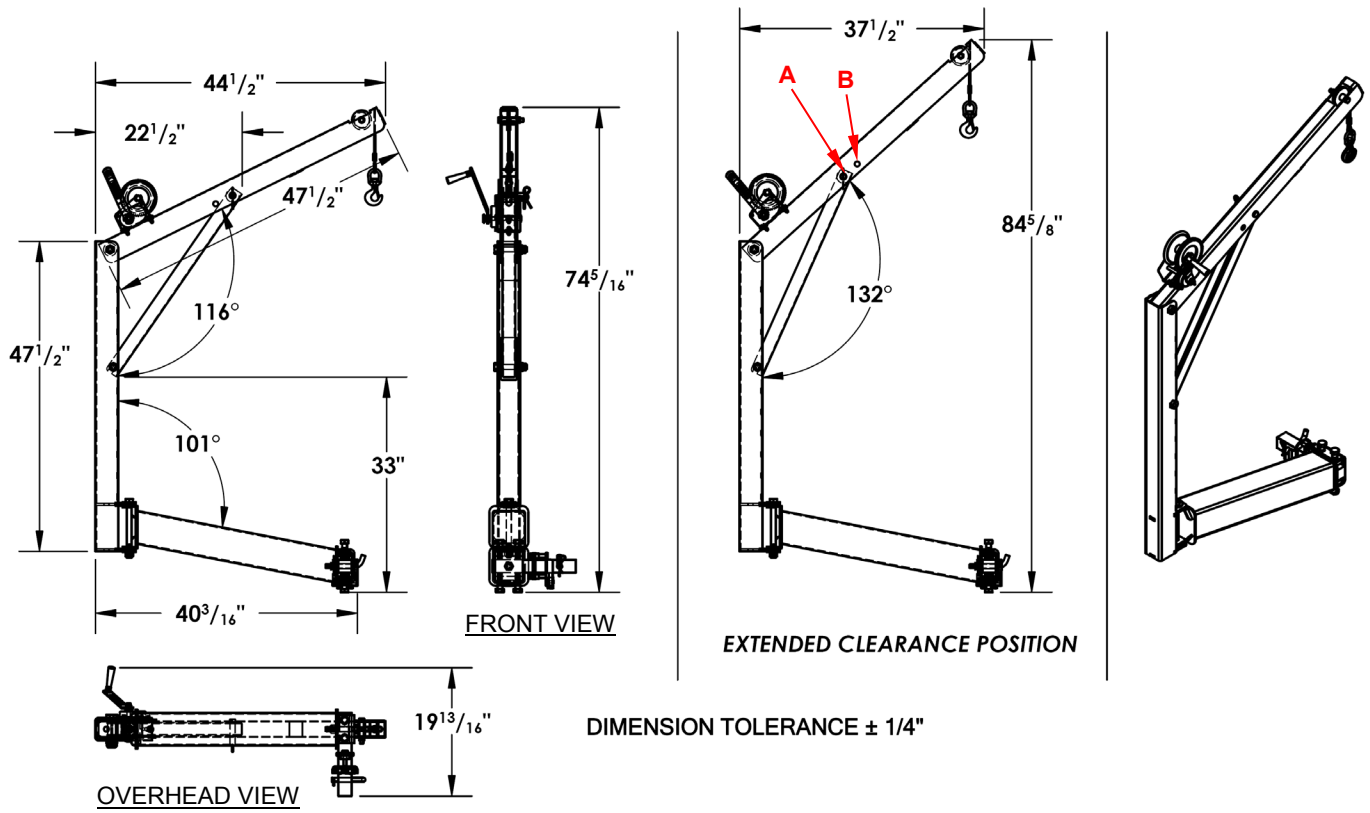

Model	Uniform capacity	Overall width	Overall length		Overall height		Net weight
			A	B	A	B	
WTJ-HITCH	600 lb. 272.7kg	$19\frac{13}{16}$ in. 50.3 cm	$40\frac{3}{16}$ in. 102.1 cm	$44\frac{1}{2}$ in. 113.0 cm	$84\frac{5}{8}$ in. 214.9 cm	$74\frac{5}{16}$ in. 188.8 cm	133.2 lb. 60.5 kg

**SIGNAL WORDS:**

This manual uses SIGNAL WORDS to identify hazards that could occur while using this product. DANGER, WARNING, and CAUTION draw attention to hazards likely to cause personal injuries. Each signal word implies a specific level of injury. NOTICE is used to indicate hazards likely to result in property damage. The following are definitions for each word.



Identifies a hazardous situation which, if not avoided, WILL result in DEATH or SERIOUS INJURY. Use of this signal word is limited to the most extreme situations.



Identifies a hazardous situation which, if not avoided, COULD result in DEATH or SERIOUS INJURY.



Indicates a hazardous situation which, if not avoided, COULD result in MINOR or MODERATE injury.



Identifies practices likely to result in product/property damage, such as operation that might damage the product.

Each person who assembles, installs, uses, or maintains this product should read the entire manual in advance and fully understand the directions. If after reading the manual you do not understand an instruction, ask your supervisor or employer for clarification, because failure to adhere to the directions in this manual might result in serious personal injury.

**Hazards:**

We strive to identify all hazards that could occur while using our products, but no manual can address every risk. The most effective way to avoid injury is to exercise sound judgment whenever using this device and to read the entire manual carefully before installing, using, or servicing the product. Vestil recommends that you contact its [Technical Service Department](#) (the “TSD”) if you have any questions about instructions in the manual. We intend to provide our customers with the best instructions possible and encourage you to contact the TSD if you believe that a necessary instruction is missing or incomplete.

**⚠️ WARNING** Improper or careless operation might result in serious personal injuries sustained by the operator and bystanders. Always apply material handling techniques learned during training and use the product properly.

- **Failure to read and understand the entire manual before assembling, using or servicing the product constitutes misuse.** Read the manual to refresh your understanding of proper use and maintenance procedures as necessary.
- **DO NOT drive with the crane fully assembled. Disconnect at least the upper assembly (post + boom + boom brace) from the base frame before driving the vehicle.**
- DO NOT use the crane unless it is in normal operating condition. Inspect the unit as described in the [Inspection](#) instructions on p. 8 to determine whether it is functioning normally. DO NOT use the crane unless it passes every part of the inspection or until it is restored to normal operating condition.
- DO NOT use a malfunctioning crane. Always perform the [Function Tests](#) (described on p. 7) before each use.
- DO NOT attempt to lift a load that weighs more than the uniform capacity of your unit. The capacity appears on label 287 as shown in “Label placement diagram” below. (Also see [Specifications](#) table on p. 2.)
- DO NOT adjust crane angle while lifting a load. ALWAYS unload the crane before [adjusting the post angle](#) as described on p. 7.
- Always watch the load carefully while raising, lowering and rotating it.
- DO NOT stand beneath or travel under the crane if a load is suspended from it and DO NOT permit any person to stand beneath or travel under the load.
- DO NOT climb on the crane or the load.
- This crane is designed for material handling ONLY. DO NOT use the crane to lift people.
- ALWAYS load the crane properly. See [Using the Crane](#) on pp. 7-8. Failure to properly position the crane and/or the load might result in serious injury to the operator or bystanders.
- DO NOT perform maintenance on this crane UNLESS it is unloaded and stably supported. If repairs are necessary, ONLY install manufacturer-approved replacement parts.
- The post of the crane (see item no. 5 on p. 4) should rotate smoothly. Watch for binding or jerky movement and listen for unusual noises. Remove the unit from service if you observe anything abnormal.
- DO NOT use the crane UNLESS all labels are in place and readable. See [Labeling Diagram](#) on p. 3.
- DO NOT modify this product in any way. Modifying the crane automatically voids the [Limited Warranty](#) (see p. 9) and might make it unsafe to use.

**NOTICE** Proper use and maintenance are essential for this product to function properly.

- Always use this product in accordance with the instructions in this manual and consistent with any training relevant to rigging used in conjunction with this product.
- Periodically lubricate pivot points.
- Keep the product clean & dry.
- Only use approved replacement parts. To order replacement parts for this equipment, contact the factory.

**Labeling diagram:**

Each pair of extensions should be labeled as shown in the diagram. However, label content and location are subject to change so your product might not be labeled exactly as shown. Replace all labels that are damaged, missing, or not easily readable (e.g. faded). To order replacement labels, contact the technical service and parts department online at [http://www.vestilmfg.com/parts\\_info.htm](http://www.vestilmfg.com/parts_info.htm). Alternatively, you may request replacement parts and/or service by calling (260) 665-7586 and asking the operator to connect you to the Parts Department.

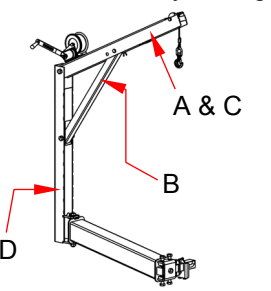

**A: Label 586 (on one side of boom)**

⚠️ WARNING	⚠️ ADVERTENCIA	⚠️ AVERTISSEMENT
<ul style="list-style-type: none"> <li>• DO NOT exceed rated capacity</li> <li>• LOWER LOAD before moving to avoid load swing</li> <li>• NEVER STAND under, beside or in front of load</li> <li>• USE on level surface</li> <li>• INSPECT connections before using</li> <li>• READ manual before use</li> </ul>	<ul style="list-style-type: none"> <li>• No exceda la capacidad tasada</li> <li>• Descienda la carga antes de mover para evitar que la carga se balancee</li> <li>• Nunca se debe detajo, al lado o delante de la carga</li> <li>• Use en una superficie a nivel dura</li> <li>• Inspeccione las conexiones antes del uso</li> <li>• Lea el manual antes del uso</li> </ul>	<ul style="list-style-type: none"> <li>• NE PAS DÉPASSER la capacité nominale</li> <li>• DESCENDRE le charge avant de la transporter pour éviter la giration</li> <li>• JAMAIS sous, mettre sous, à côté de ou devant une charge</li> <li>• UTILISER sur un sol plat et dur</li> <li>• INSPECTER les connexions avant utilisation</li> <li>• LIRE le guide avant utilisation</li> </ul>

**B: Label 208 (top of boom brace)**

⚠️ WARNING	⚠️ ADVERTENCIA	⚠️ AVERTISSEMENT
KEEP CLEAR OF PINCH POINT	MANTENGASE ALEJADO DEL PUNTO DE CORTE	SE TENIR A DISTANCE DU POINT DE PINCEMENT

**C: Label 983 (on other side of boom)**

⚠️ WARNING	⚠️ ADVERTENCIA
<p><b>IMPROPER OR CARELESS OPERATION MIGHT RESULT IN SERIOUS PERSONAL INJURY</b></p> <ul style="list-style-type: none"> <li>• DO NOT drive with the crane fully assembled. Disconnect at least the upper assembly (post + boom + boom brace) from the base frame before driving the vehicle.</li> <li>• This crane is designed for material handling ONLY. DO NOT use the crane to lift people.</li> <li>• DO NOT modify this product in any way. Modifying the crane automatically voids the limited warranty and might make it unsafe to use.</li> <li>• DO NOT perform maintenance on this crane UNLESS it is unloaded and stably supported. If repairs are necessary, ONLY install manufacturer-approved replacement parts.</li> </ul>	<p><b>EL MAL USO O LA OPERACIÓN IMPRODENTE PUEDE RESULTAR EN DAÑOS SERIOS AL PERSONAL</b></p> <ul style="list-style-type: none"> <li>• NO conducir con la grúa totalmente ensamblada. Desconecte como mínimo el conjunto superior (poste + brazo + brazo de apoyo) de la estructura antes de conducir el vehículo.</li> <li>• Esta grúa está diseñada SOLO para el manejo de materiales. NO USE la grúa para elevar a las personas.</li> <li>• No modifique este producto de ninguna manera. Cualquier modificación de la grúa anula la garantía limitada y podría hacer que la grúa no sea segura para su uso.</li> <li>• No realice ninguna reparación en esta grúa UNLESS que está descargada y apoyada de forma adecuada. Si las reparaciones son necesarias, SOLO instale partes de reemplazo que estén aprobadas por el fabricante.</li> </ul>

**D: Label 287 (on side of post)**

MODEL/MODE LO/MODELE	lbs.
CAPACITY/CAPACITE	kgs.
SERIAL/SERIE/SERIE	
VESTIL MANUFACTURING CORPORATION	
sales@vestil.com • www.vestil.com	

### Exploded View & Bill of Materials

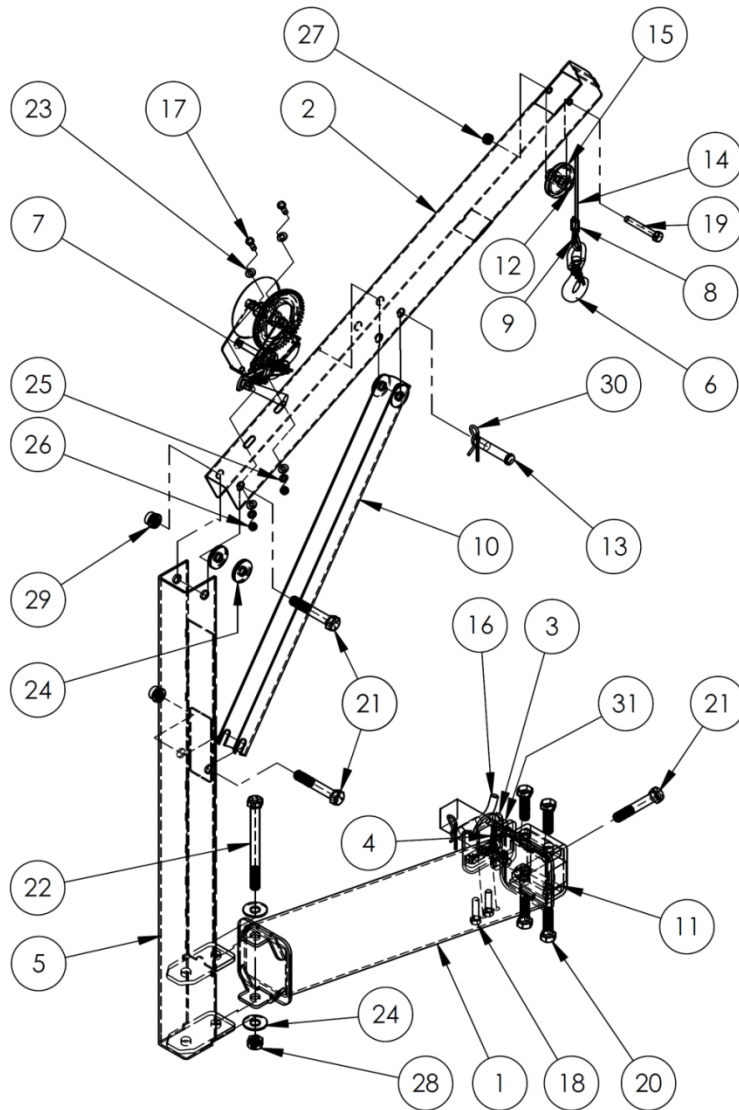

**Tools needed for assembly:**

- 1 1/8 in. wrenches (for 20, 21, 22 & 28)
- 9/16 in. wrenches (for 17 & 26)
- 3/4 in. wrenches (for 18, 19, 27, & 31)

Item	Part no.	Description	Qty.	Item	Part no.	Description	Qty.
1	28-514-251	Assembly, base frame	1	16	99-612-003	Assembly, hitch pin and pin clip	1
2	28-514-252	Assembly, boom	1	17	13105	3/8" -16 x 1" HHCS #5 z-plated bolt	2
3	28-516-065	Assembly, bracket, hitch collar	1	18	13211	1/2" - 13 x 2" HHCS #5 z-plated bolt	4
4	28-516-066	Assembly, bracket hitch tube	1	19	13217	1/2" - 13 x 3 1/2" HHCS #5 z-plated bolt	1
5	28-516-067	Assembly, bracket, post	1	20	13363	3/4" - 10 x 2 1/2" HHCS #5 z-plated bolt	4
6	08-145-037	1-ton clevis hook	1	21	13371	3/4" - 10 x 4 1/2" HHCS #5 bolt	3
7	21-042-002-001	Hand winch, foldable handle grip	1	22	17945	3/4" - 16 x 8 1/2" yellow zinc grade 8 bolt	1
8	99-145-067	Compression sleeve, 3/16" x 1"	1	23	33008	3/8" USS flat washer z-plated	4
9	21-145-013	Thimbles, LLW	1	24	33018	3/4" USS flat washer z-plated	8
10	28-014-380	Frame, boom brace	1	25	33622	3/8" lock washer z-plated	2
11	28-016-213	Bracket, threaded hitch stiffener	2	26	36106	3/8" - 16 hex nut z-plated	2
12	28-027-010	Roller	2	27	36110	1/2" - 13 hex nut z-plated	1
13	33-112-034	Clevis pin, 3/4" x 3 3/4" long	1	28	36466	3/4" - 16 yellow zinc grade 8 hex nut	1
14	42-145-004	3/16" aircraft cable, 180" long	1	29	37039	3/4" - 10 nylock nut z-plated	2
15	99-027-003	1/4" cable pulley, 3" OD, 1/2" ID	1	30	45282	#6 hitch pin clip	1
				31	48593	1/2" - 13 x 1 5/8" channel nut	4

### Assembling the Crane:

In the assembly instructions below, numbers in parentheses correspond to item numbers in the exploded parts diagram on p. 4.

**Step 1A:** Attach the hitch collar (3) to the hitch tube (4) with  $\frac{1}{2}$ in. – 13 x 2in. bolts (18). Install the collar on an end of the tube as shown below. Do not tighten the bolts against the bottom of the hitch tube.

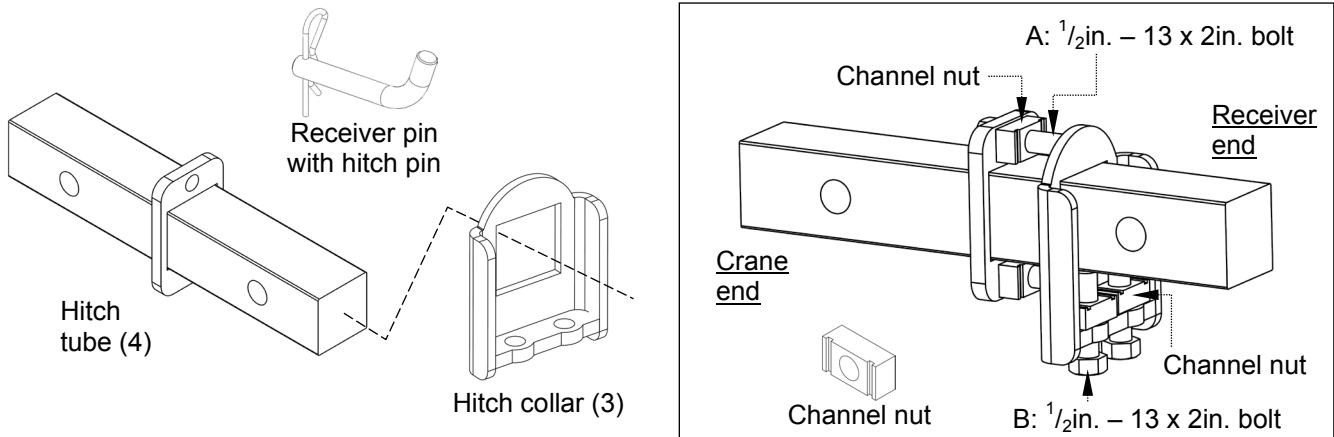

**Step 1B:** Insert the receiver end of the hitch tube into the receiver of your trailer hitch. Pin the hitch bar to the receiver using the receiver pin and pin clip (items 16 & 30). Next, slide the collar around the end of the receiver and tighten the bolts (B) firmly against the bottom of the receiver.

**Step 2:** Slide the base frame (1) onto the crane end of the hitch bar. Attach the components as shown below with  $\frac{3}{4}$ in. – 10 x 2 $\frac{1}{2}$ in. bolts (20). Then, install the  $\frac{3}{4}$ in. – 10 x 4 $\frac{1}{2}$ in. bolt (21) through the tube bracket, hitch tube, and into the base frame and tighten it.

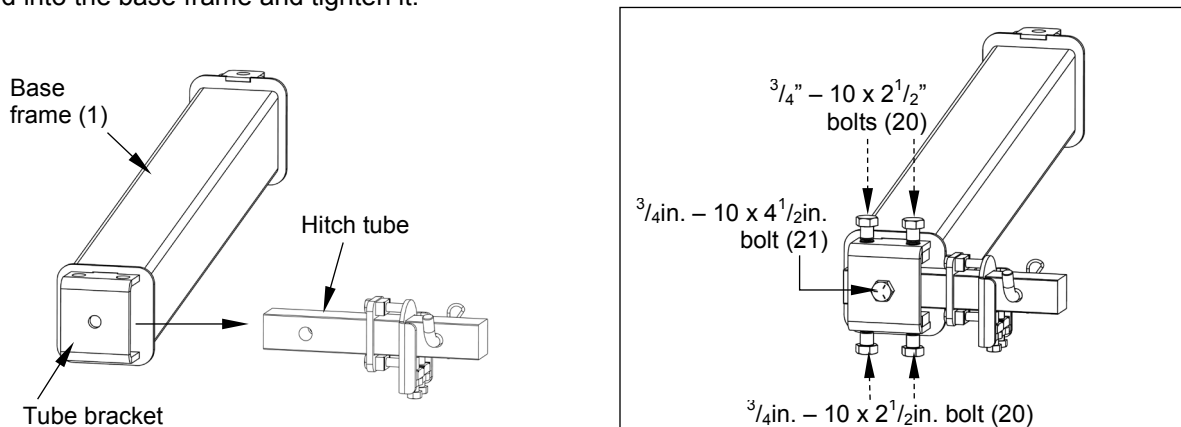

**Step 3:** Attach the post (5) to the base frame using the  $\frac{3}{4}$ in. – 16 x 8 $\frac{1}{2}$  bolt (22),  $\frac{3}{4}$ in. – 16 hex nut (28), and  $\frac{3}{4}$ in. flat washers (24).

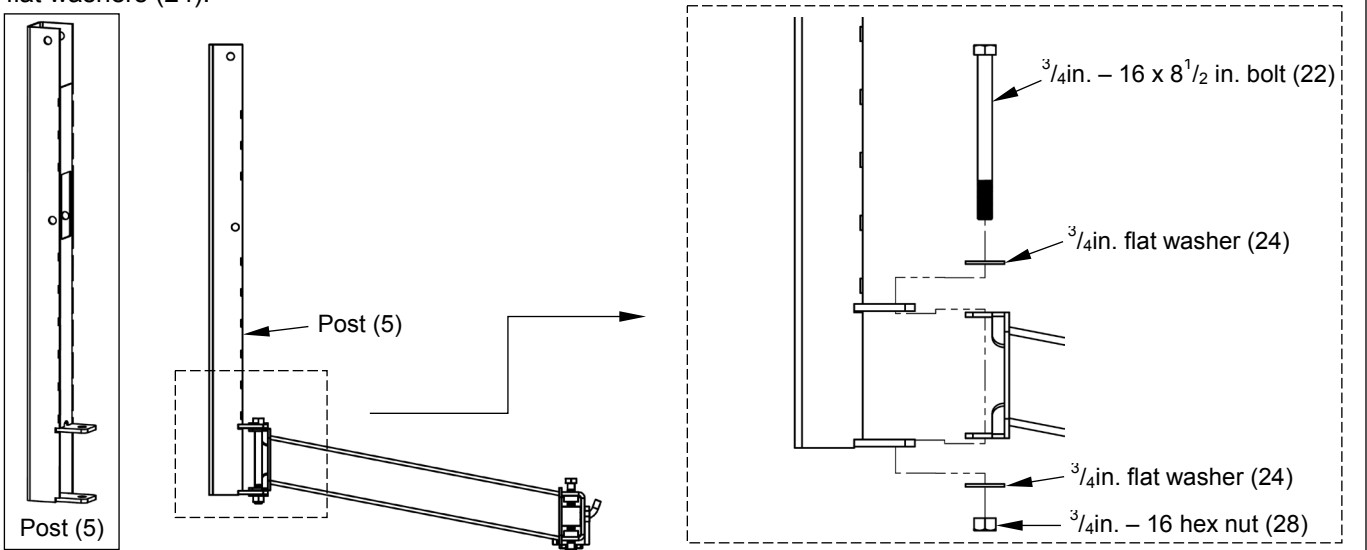

**Step 4:** Attach the boom (2) to the top of the post with a  $\frac{3}{4}$ in. – 10 x  $4\frac{1}{2}$ in. bolt (21), four  $\frac{3}{4}$ in. flat washers (24), and a  $\frac{3}{4}$ in. – 10 hex nut (29). Include washers as needed on either side of the boom on the inside of the post as shown below to tighten the connection.

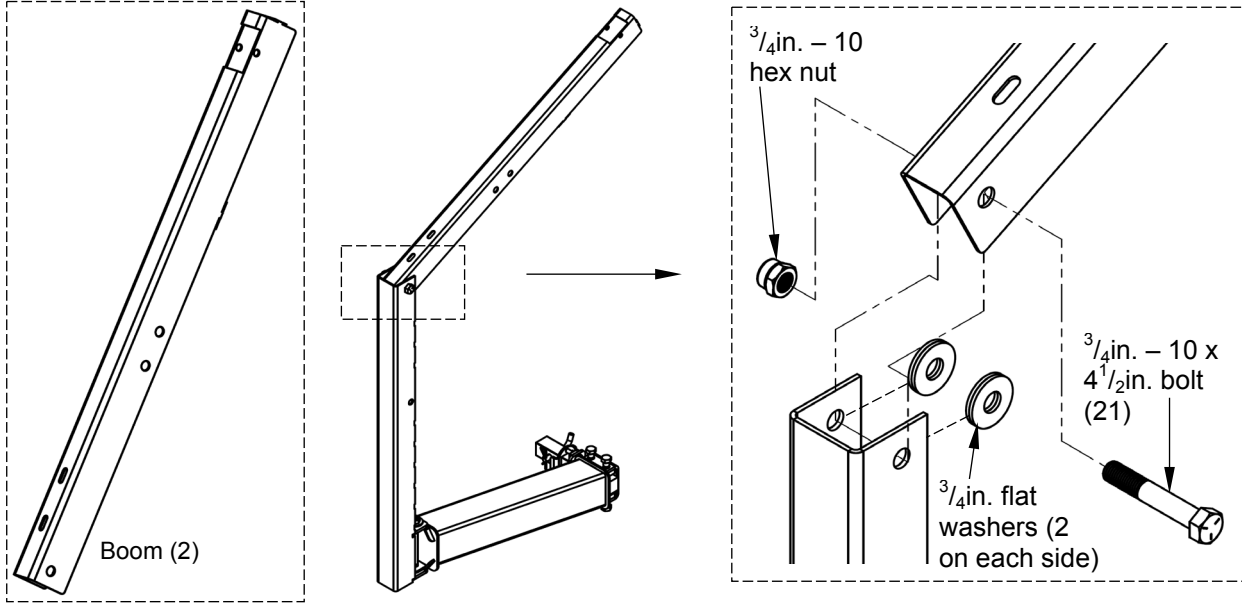

**Step 5:** Attach the boom brace (10) to the post and the boom. For the lower connection, use a  $\frac{3}{4}$ in. – 10 x  $4\frac{1}{2}$ in. bolt (21) and  $\frac{3}{4}$ in. – 10 lock nut (29). Notice that at one end of the brace is a pair of  $\frac{3}{4}$ in. holes and at the other end is a pair of slots. The slotted end of the brace is the bottom end. First, install the bolt through the holes in the center of the post and fasten it on the other side with a  $\frac{3}{4}$ in. lock nut. Then, slide the slotted end of the brace onto the bolt. Select one of the two attachment positions (A and B below; see diagrams on p. 2) and fasten the brace to the boom at that location with a  $\frac{3}{4}$ in. x  $3\frac{3}{4}$ in. clevis pin (13) and #6 hitch pin (30). Use  $\frac{3}{4}$ in. flat washers (24) on both sides of the brace inside the boom to tighten the connection, if necessary.

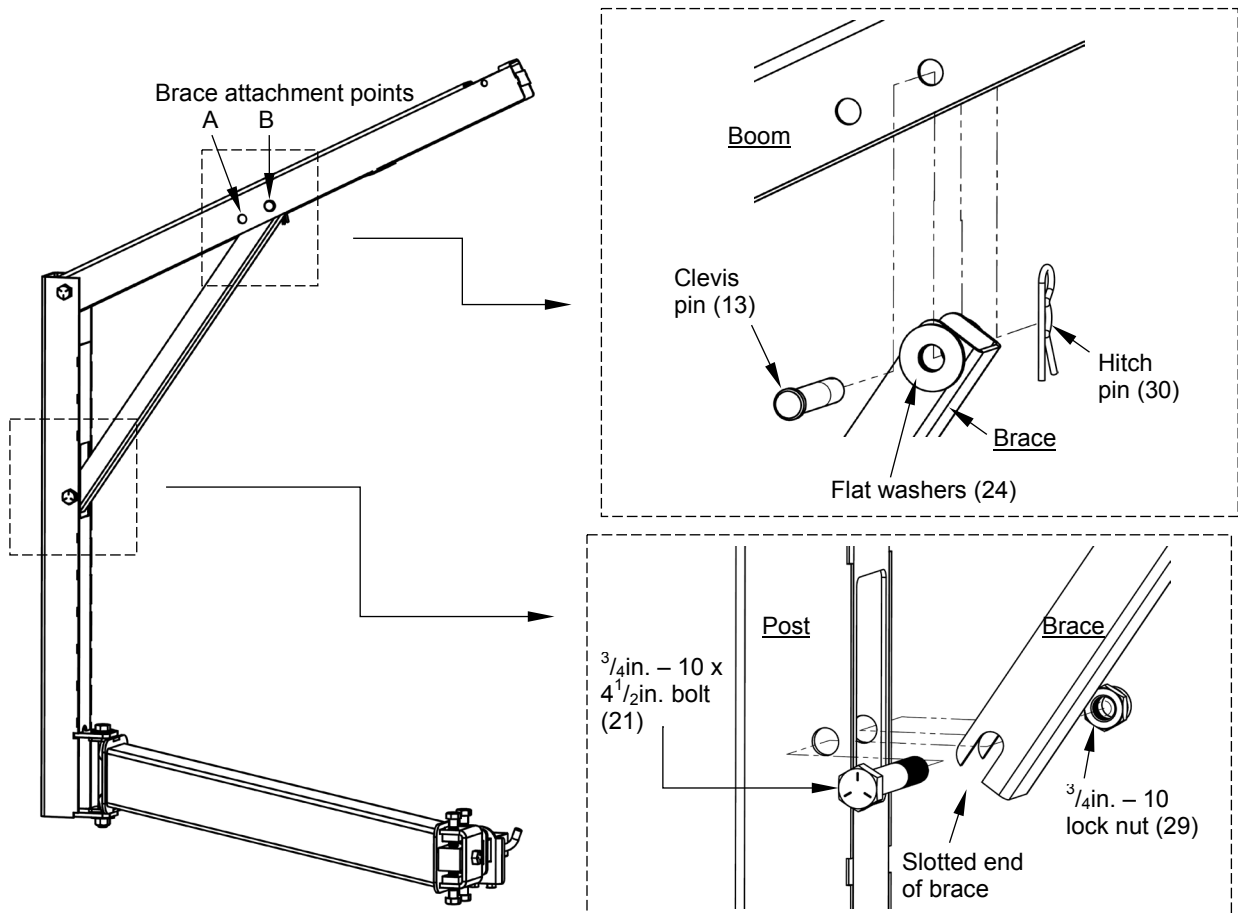

**Step 6:** Attach the winch (7) to the boom using  $\frac{3}{8}$ in. hardware (17, 23, 25, & 26).

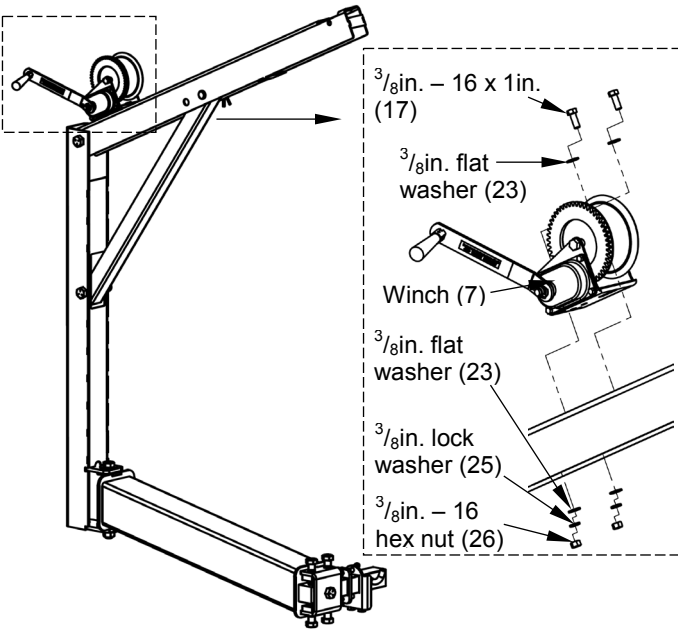

**Step 7:** Install the cable pulley (15) at the end of the boom. First, feed the load hook and cable through the opening at the end of the boom (not shown); then attach the two rollers (12; one on each side of pulley) and the cable pulley using a  $\frac{1}{2}$ in. - 13 x  $3\frac{1}{2}$ in. bolt (19) and  $\frac{1}{2}$ in. - 13 hex nut (27) as shown in the diagram below.

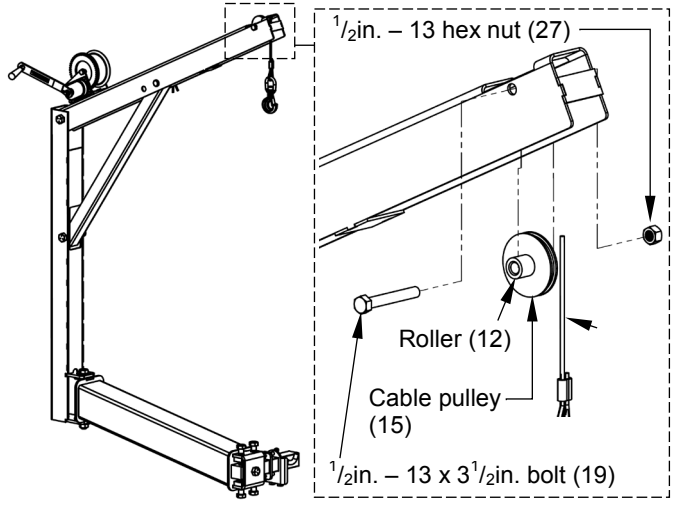

**Post angle adjustments:**

The crane base can be rotated by up to 10° in either direction, which also changes the position of the post. To change the angle, first adjust the bolts in the top of the tube bracket. When the desired angle is achieved, tighten the bolts in the bottom of the tube bracket.

**NOTE:** Lifting a load with the crane causes the frame of the vehicle to shift. This shift also causes the angle of the crane (relative to vertical) to change. Adjust the crane angle to account for the change that occurs under load. **When properly adjusted, the post should be vertical while the crane is loaded.** Once loaded if the angle must be adjusted, lower and disconnect the load before making the adjustment.

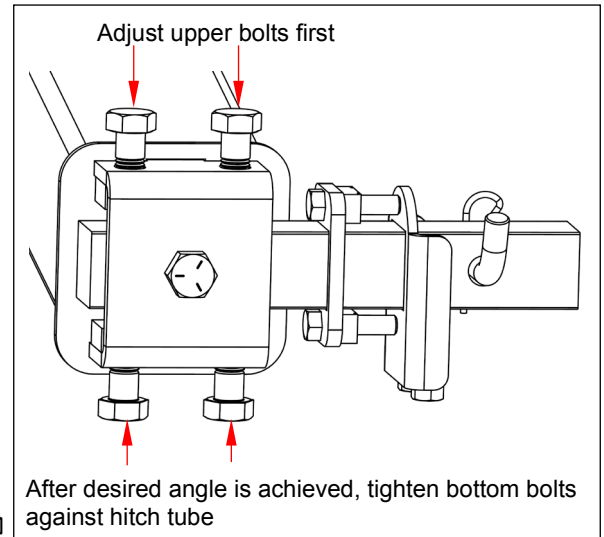
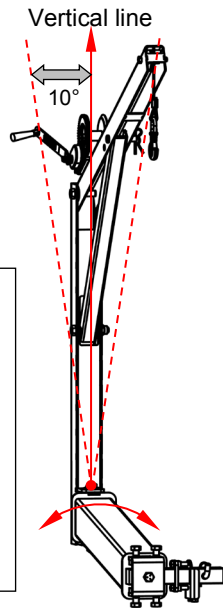

**Using the crane:**

Proper operation is essential to reduce the likelihood of personal injury. Before using the crane, ALWAYS conduct the “Function Tests” described below. Compare items to the *Record of Normal Condition* whenever the following instructions call for an inspection/examination.

Function Tests:

Before using the crane, verify that it is in normal condition. If the crane fails any of the following tests do NOT use it. Tag the crane “Out of Service”, remove it from service, and report the problem to authorized inspection and maintenance personnel. DO NOT use the crane again until it is restored to normal operating condition.

1. Test the pivot action: confirm that the post pivots normally about the 8 1/2 in. bolt (item no. 22 on p. 4).
2. Test the winch: Lower and raise the load hook. Confirm that the cable unwinds and rewinds smoothly.
3. Inspect the cable: look for kinks, frayed or broken wires, bird-caging, etc. Replace the cable if it is significantly worn or damaged.
4. Examine the hook: the hook must not be twisted, cracked, elongated, etc. Replace the hook if it is damaged.

Proper loading:

Before using the crane, prepare the vehicle. Park the vehicle on level ground and engage the parking brake. If you will use the crane on a pickup truck, it might be necessary to lower or remove the tailgate to accommodate the load. Recall that the boom brace can be attached to the boom at either of 2 positions (see Step 5 on p. 6). Attaching the

brace to position A will allow you to raise loads as high as possible. Attachment to position B optimizes boom reach (horizontal distance) but does not allow loads to be lifted as high. Select the appropriate attachment point for the brace and then proceed to the next step.

Next, bring the load to the vehicle. Rotate the boom away from the vehicle and position the load directly below the load hook. Attach necessary rigging to the load; then attach the load hook to the rigging.

Slowly raise the load off of the ground with the winch. Observe both the crane and the load as the load rises. Make sure that the load does not swing, because the post will tilt slightly under the weight of a load. Observe the crane post and make sure that it is substantially vertical while the load is applied. When the load is adequately elevated, slowly push the load into the vehicle and lower it until it is fully supported by the vehicle. Next, disconnect the load hook from the rigging and turn the winch until the hook is fully retracted.

Do not drive while the crane is attached to the vehicle. Either disconnect the entire crane assembly by pulling the hitch tube out of the receiver, OR remove the 8<sup>1</sup>/<sub>2</sub>in. bolt (22) that fastens the upper assembly (post, boom, and brace) to the base frame.

#### Lowering the tailgate:

The tailgate of some trucks cannot be lowered without contacting the boom brace. The crane is designed to address this issue without having to disconnect hardware:

- First, retract the load cable;
- Then, grasp the bottom of the boom brace and lift it off of the supporting bolt. The bottom of the brace is slotted to facilitate quick disengagement from the bolt.
- Carefully rotate the boom up and over the top of the post (as shown in the diagram to the right) until it rests on the top of the post.

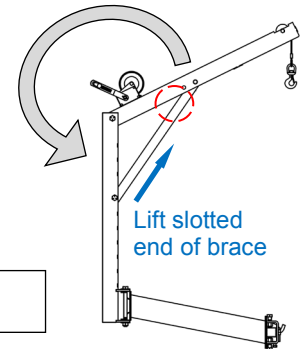

**WARNING** Avoid the pinch point between the brace and boom (dashed circle).

## Record of Normal Condition:

Before putting the crane into service, create a record of its original condition. Thoroughly photograph the assembled and installed crane from multiple vantage points. Closely photograph all pivot points, connections, and fasteners. Photograph all labels. Describe the appearance of the crane including locations of all labels. Also describe the operation of the winch mechanism by using the crane to lift a test load. Add your notes to the record file. This record establishes normal condition of the crane.

## Inspections and Maintenance:

Crane owners and operators should regularly inspect this crane to confirm that it is in normal working condition. Occupational Safety and Health Administration (OSHA) crane inspection procedures appear in 29 CFR 1910.179 (visit <http://www.osha.gov/> and navigate to "Regulations" section 1910.179; relevant portions of those procedures appear in paraphrase below). Compare your observations to the *Record of Normal Condition*. Replace all items that are not in normal condition before returning the crane to service.

1. **Initial inspection** — before using a new crane for the first time, inspect it to insure normal condition.

#### After the first use, conduct the following inspections:

2. **Frequent inspection** — inspect the following items for defects at the intervals indicated, including observation *during operation* for any defects which might appear between inspections. All deficiencies such as those listed shall be carefully examined to determine whether they constitute a safety hazard:
  - All functional operating mechanisms (pulley, cable, winch, post): inspect daily for maladjustment interfering with proper operation. Verify that the winch rotates normally in both directions. The pulley should rotate freely as the cable extends and retracts. The post should rotate smoothly and easily.
  - Load Hook: visually inspect the load hook before each use. Also inspect the hook once per month and record the results of the inspection. Examine the hook for deformation or cracks. Immediately discard the hook if it is cracked or if the throat opening is more than 15 percent in excess of normal throat opening. Discard the hook if it is twisted more than 10° from the plane of the unbent hook.
  - All frame pieces (hitch tube, base frame, post, boom and boom brace) and all fasteners (bolts, nuts, pins): Inspect weekly for damage: excessive wear, warps, and cracks. Replace all parts that are damaged before using the crane again. All frame pieces should be square, rigid and free of rust and corrosion. Remove any rust with a steel wool or a metal bristle brush and apply touch-up paint designed for coating metal and for outdoor use.
  - Cable: Inspect weekly for reeving, kinks, frays, elongations, bird-caging, etc. Replace the cable if it is damaged.
  - Pivot points: inspect all pivot points at least once per month, especially the connections between the base frame and the post, for significant wear. Apply grease to the pivot points.

## LIMITED WARRANTY

Vestil Manufacturing Corporation (“Vestil”) warrants this product to be free of defects in material and workmanship during the warranty period. Our warranty obligation is to provide a replacement for a defective, original part covered by the warranty after we receive a proper request from the Warrantee (you) for warranty service.

### Who may request service?

Only a warrantee may request service. You are a warrantee if you purchased the product from Vestil or from an authorized distributor AND Vestil has been fully paid.

### Definition of “original part”?

An original part is a part used to make the product as shipped to the Warrantee.

### What is a “proper request”?

A request for warranty service is proper if Vestil receives: 1) a photocopy of the Customer Invoice that displays the shipping date; AND 2) a written request for warranty service including your name and phone number. Send requests by one of the following methods:

US Mail	Fax	Email
Vestil Manufacturing Corporation 2999 North Wayne Street, PO Box 507 Angola, IN 46703	(260) 665-1339 <u>Phone</u> (260) 665-7586	info@vestil.com Enter “Warranty service request” in subject field.

In the written request, list the parts believed to be defective and include the address where replacements should be delivered. After Vestil receives your request for warranty service, an authorized representative will contact you to determine whether your claim is covered by the warranty. Before providing warranty service, Vestil will require you to send the entire product, or just the defective part (or parts), to its facility in Angola, IN.

### What is covered under the warranty?

The warranty covers defects in the following original, dynamic parts: motors, hydraulic pumps, motor controllers, and cylinders. It also covers defects in original parts that wear under normal usage conditions (“wearing parts”), such as bearings, hoses, wheels, seals, brushes, and batteries.

### How long is the warranty period?

The warranty period for original dynamic components is 90 days. For wearing parts, the warranty period is 90 days. Both warranty periods begin on the date Vestil ships the product to the Warrantee. If the product was purchased from an authorized distributor, the periods begin when the distributor ships the product. Vestil may, at its sole discretion, extend a warranty period for products shipped from authorized distributors by up to 30 days to account for shipping time.

### If a defective part is covered by the warranty, what will Vestil do to correct the problem?

Vestil will provide an appropriate replacement for any *covered* part. An authorized representative of Vestil will contact you to discuss your claim.

### What is not covered by the warranty?

The Warrantee (you) is responsible for paying labor costs and freight costs to return the product to Vestil for warranty service.

### Events that automatically void this Limited Warranty.

- Misuse;
- Negligent assembly, installation, operation or repair;
- Installation/use in corrosive environments;
- Inadequate or improper maintenance;
- Damage sustained during shipping;
- Collisions or other accidents that damage the product;
- Unauthorized modifications: Do not modify the product IN ANY WAY without first receiving written authorization from Vestil.

### Do any other warranties apply to the product?

Vestil Manufacturing Corp. makes no other express warranties. All implied warranties are disclaimed to the extent allowed by law. Any implied warranty not disclaimed is limited in scope to the terms of this Limited Warranty. Vestil makes no warranty or representation that this product complies with any state or local design, performance, or safety code or standard. Noncompliance with any such code or standard is not a defect in material or workmanship.

