

- * Suitable for children of 3+ years old; Max weight: 15 kg/layer.
- * Adequado para crianças de 3+ anos; Poids Max : 15 kg/tiroir.
- * Geeignet für Kinder im Alter von 3+ Jahren; Max. Gewicht: 15 kg/Schicht.
- * Adequado para los niños de 3+ años; Carga máxima: 15 kg/capa
- * Adatto a bambini di 3+ anni; Peso massimo: 15 kg/strato.

EN_IMPORTANT, RETAIN FOR FUTURE REFERENCE: READ CAREFULLY.

FR_IMPORTANT: A LIRE ATTENTIVEMENT ET À CONSERVER POUR CONSULTATION ULTÉRIURE.

ES_IMPORTANTE, LEA Y GUARDE PARA FUTURAS REFERENCIAS.

DE_WICHTIG! SORGFÄLTIG LESEN UND FÜR SPÄTER NACHSCHLAGEN AUFBEWAHREN.

IT_IMPORTANTE! CONSERVARE IL PRESENTE MANUALE PER FUTURO RIFERIMENTO E LEGGERLO ATTENTAMENTE.

EN

 **WARNING**

- 1.This product is suitable for children over 3 years old.
- 2.Please use under adult supervision ,Children are prohibited from climbing and trampling to avoid caused dangerous.
- 3.Store in a cool and dry place ,away from all sources of heat and fire, and avoid direct sunlight.
- 4.Don't place in water or permeate the ground, Don't on uneven ground or slope.
- 5.After unpacking, please keep the bags and accessories out of children's reach to prevent suffocation and other accidents.
- 6.Please check whether all parts installed in place and connected firmly before use.
- 7.Only adults are allowed to install. Children should not be approach. Please be careful of clamping when installing.

Maintenance Method

- 1.Please Wipe the surface regularly with half dry rag, when necessary, Please gentle soapy /cleanser. dont clean it with strong cleanser.
- 2.Be sure to keep the product away from sharp objects to prevent scratches or damage.
- 3.Please put the product in a cool and dry place and cover it with clean cloth or blanket(do not use plastic) if it is not used for a long time.

FR

 **AVERTISSEMENT**

- 1.Ce produit convient aux enfants de plus de 3 ans
- 2.Veuillez à ce qu'il soit utilisé sous la surveillance d'un adulte. Il est interdit aux enfants de grimper et de piétiner pour éviter que cela ne cause un danger.
- 3.Rangez dans un endroit frais et sec, loin de toute source de chaleur et de feu, et évitez la lumière directe du soleil.
- 4.Ne pas placer dans l'eau ou dans un sol perméable, ne pas placer sur un sol inégal ou en pente.
- 5.Après le déballage, veuillez garder les sacs et les accessoires hors de portée des enfants afin d'éviter la suffocation et d'autres accidents
- 6.Veuillez vérifier que toutes les pièces sont bien en place et bien connectées avant toute utilisation.
- 7.Seuls les adultes sont autorisés à installer le produit. Les enfants ne doivent pas être approchés. Veuillez faire attention au serrage lors de l'installation.

Méthode de Maintenance

- 1.Veuillez essuyer la surface régulièrement avec un chiffon demi-sec, si nécessaire, veuillez utiliser un savon doux/nettoyant, mais pas de nettoyant puissant.
- 2.Veuillez à tenir le produit à l'écart des objets tranchants pour éviter les rayures ou les dommages.
- 3.Mettez le produit dans un endroit frais et sec et couvrez-le avec un chiffon propre ou une couverture (n'utilisez pas de plastique) s'il n'est pas utilisé pendant une longue période.

 **WARNUNG**

1. Dieses Produkt ist für Kinder ab 3 Jahren geeignet
2. Zur Verwendung unter der Aufsicht von Erwachsenen benutzen, Kindern ist das Klettern und Trampeln verboten, um Gefahren zu vermeiden.
3. Lagern Sie das Gerät an einem kühlen und trockenen Ort, entfernt von allen Wärme- und Feuerquellen, und vermeiden Sie die direkte Sonneneinstrahlung.
4. Stellen Sie es nicht in Wasser stellen oder lassen Sie Flüssigkeiten in den Boden eindringen. Stellen Sie es nicht auf unebenen Flächen oder in einer Schräglage auf.
5. Bitte bewahren Sie die Taschen und das Zubehör nach dem Auspacken außerhalb der Reichweite von Kindern auf, um ein Erstickungs- und Unfallrisiko zu vermeiden.
6. Bitte prüfen Sie vor der Verwendung, ob alle Teile korrekt montiert und fest angeschlossen sind.
7. Die Montage darf nur von Erwachsenen durchgeführt werden. Kinder sollten ferngehalten werden. Bitte achten Sie bei der Montage auf Klemmungen.

Wartungsmethode

1. Bitte wischen Sie die Oberfläche regelmäßig mit einem halbtrockenen Lappen ab, wenn nötig, bitte mit einer sanften Seifenlösung/Reinigungsmittel.
2. Achten Sie darauf, das Produkt von scharfen Gegenständen fernzuhalten, um Kratzer oder Beschädigungen zu vermeiden.
3. Bitte lagern Sie das Produkt an einem kühlen und trockenen Ort und decken Sie es mit einem sauberen Tuch oder einer Decke ab (kein Plastik verwenden), wenn es längere Zeit nicht benutzt wird.

 **ADVERTENCIA**

1. Este producto es adecuado para los niños mayores de 3 años.
2. Los niños solo pueden utilizar la estantería bajo la supervisión de adulto, están prohibidos trepar y pisotear sobre la estantería en el motivo de evitar daños.
3. Guarde la estantería en un lugar fresco y seco, lejos de las fuentes de calor y fuego, y evite la luz solar directa.
4. No coloque la estantería en el agua ni entierre en el suelo, no la coloque sobre un terreno irregular o en pendiente.
5. Después de desembalar la caja, mantenga las bolsas y los accesorios fuera del alcance de los niños con el fin de evitar asfixia y otros accidentes.
6. Asegúrese de que todas las piezas están instaladas en su lugar y conectadas firmemente antes de utilizar la estantería.
7. Solo los adultos pueden realizar la instalación. Cuando instale la estantería, los niños no deben acercarse. Tenga cuidado para evitar pellizcos al instalarla.

Método de mantenimiento

1. Por favor limpie la superficie periódicamente con paño un poco húmedo, cuando sea necesario, utilice un jabón / limpiador suave. No la limpie con limpiador fuerte.
2. Asegúrese de mantener la estantería alejada de los objetos afilados con el fin de evitar arañazos o daños.
3. Coloque la estantería en un lugar fresco y seco y cúbrala con una tela limpia o una manta (no utilice plástico) si no está en uso durante mucho tiempo.

AVVERTENZE





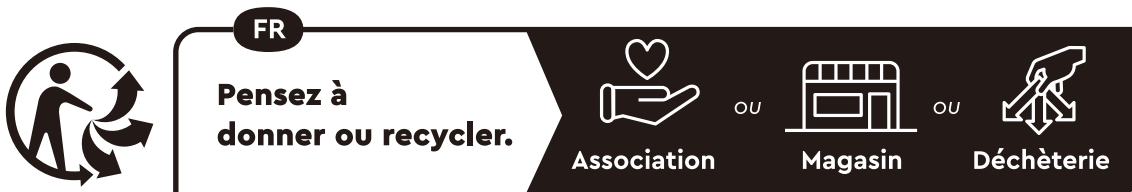

1. Questo prodotto è adatto a bambini di età superiore a 3 anni
2. Si prega di utilizzare sotto la supervisione di un adulto, inoltre ai bambini è vietato arrampicarsi e calpestare il prodotto per evitare pericoli.
3. Conservare in un luogo fresco e asciutto, lontano da fonti di calore e fiamme ed evitare la luce solare diretta.
4. Non immergere in acqua o piantare nel terreno, non posizionare su terreno irregolare o in pendenza.
5. Dopo il disimballaggio, tenere la confezione e gli accessori fuori dalla portata dei bambini per evitare il soffocamento e altri incidenti.
6. Si prega di controllare se tutte le parti sono installate in posizione corretta e collegate saldamente prima dell'uso.
7. Solo gli adulti possono installare il prodotto. I bambini non devono avvicinarsi durante il processo. Fare attenzione a stringere saldamente le parti durante l'installazione.

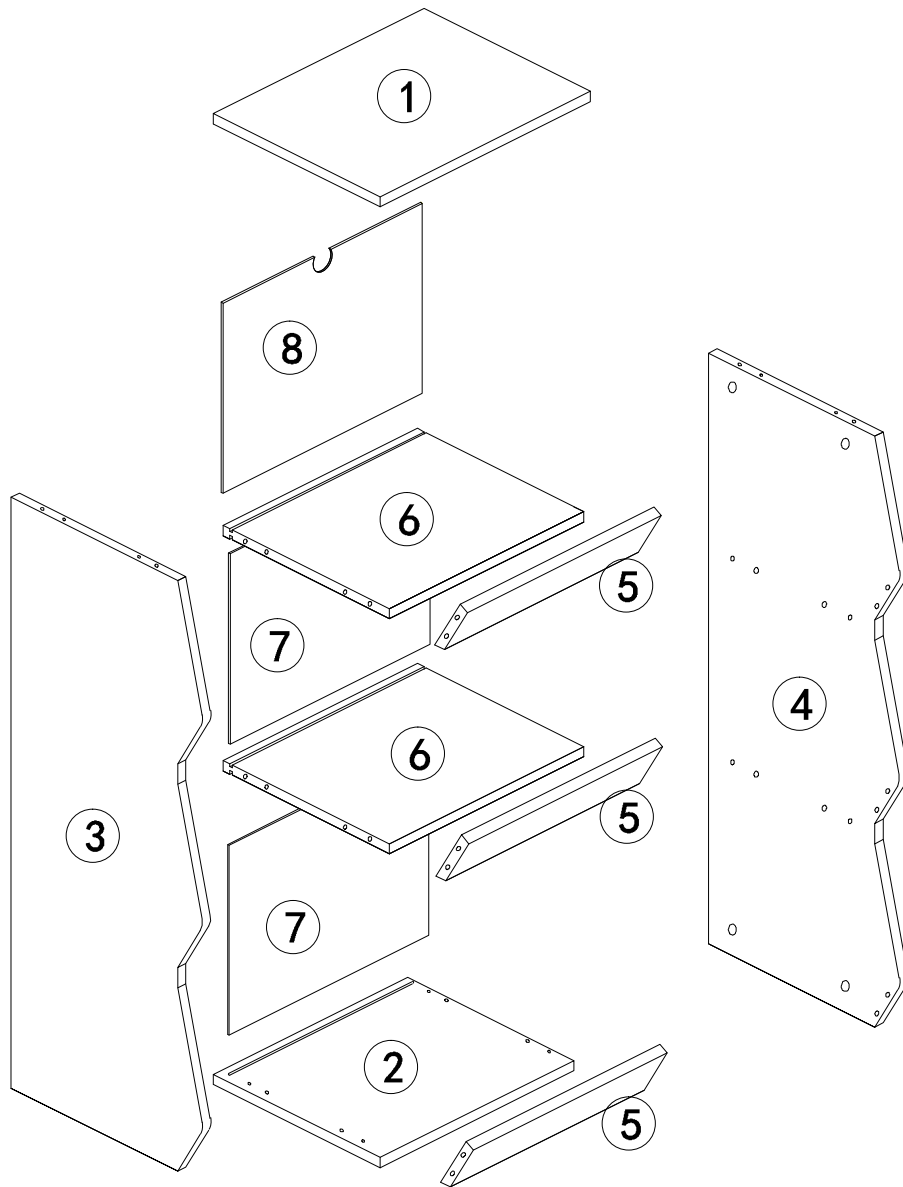
Metodo di manutenzione

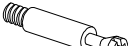
1. Si prega di pulire regolarmente la superficie con uno straccio mezzo asciutto e, se necessario, si prega di usare solo sapone delicato / detergente. Non pulire con un detergente abrasivo.
2. Assicurarsi di tenere il prodotto lontano da oggetti appuntiti per evitare graffi o danni.
3. Si prega di posizionare il prodotto in un luogo fresco e asciutto e di coprirlo con un panno pulito o una coperta (non usare un telo di plastica) se non viene utilizzato a lungo.







A1  $\varnothing 12 \times 10 \text{mm}$ x 16	B  $\varnothing 6.5 \times 38 \text{mm}$ x 16	C1  $\varnothing 6 \times 30 \text{mm}$ x 28	D  x 4	E3  M3.5x 12mm x 1
E5  M3x 16mm x 6	N  x 6	P  x 1		

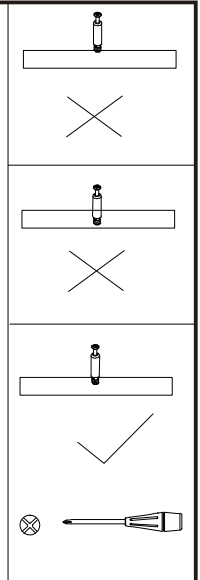
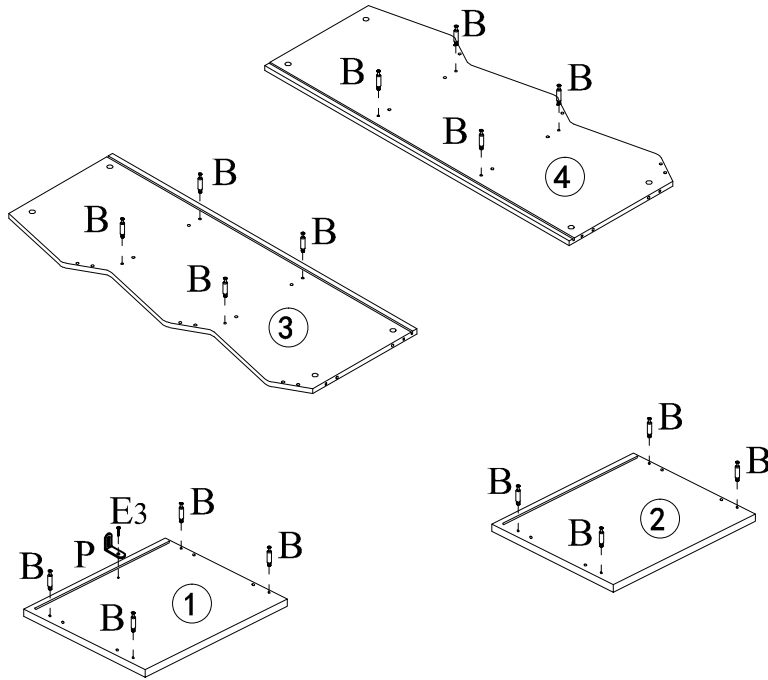
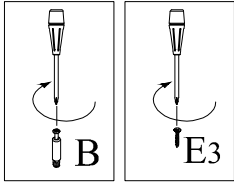

1

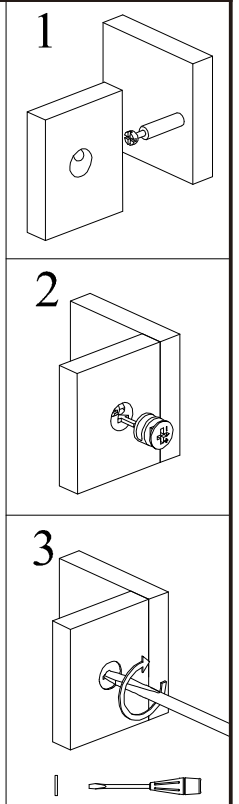
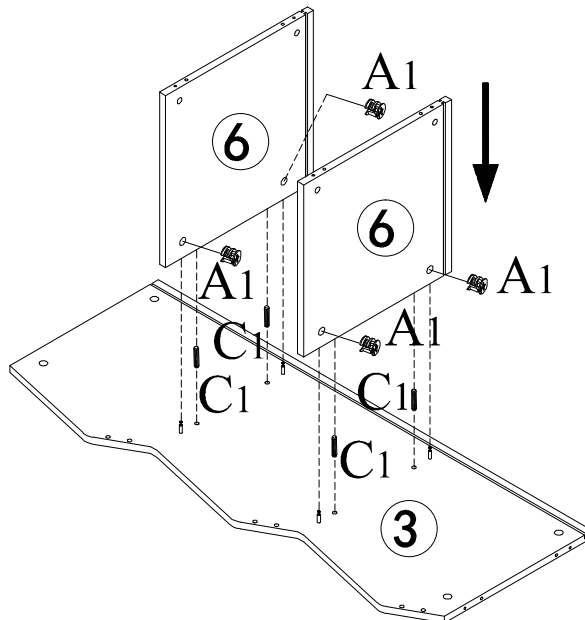

<p>P</p>  <p>x1</p>	<p>E3</p>  <p>M3.5x 12mm</p> <p>x1</p>	<p>B</p>  <p>Ø6.5 x 38mm</p> <p>x16</p>
--	---	--

2



<p>A1</p>  <p>Ø12x10mm</p> <p>x 4</p>	<p>C1</p>  <p>Ø6 x 30mm</p> <p>x4</p>
--	--

3

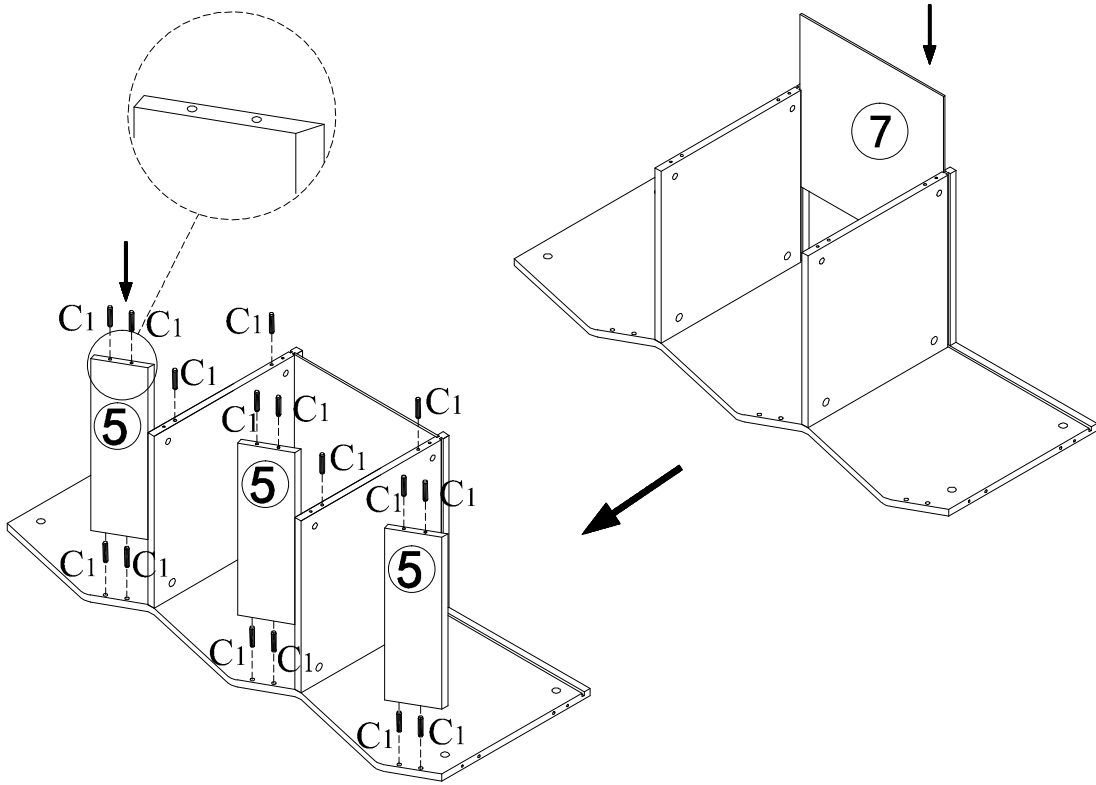

C1
Ø6 x 30mm
x16

4

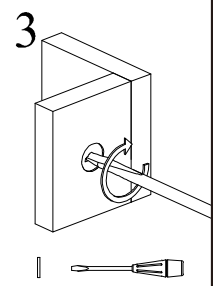
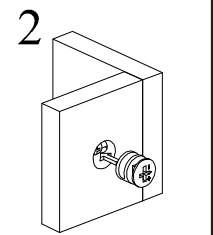
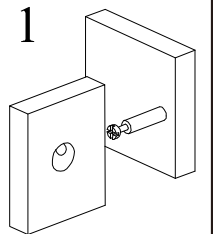
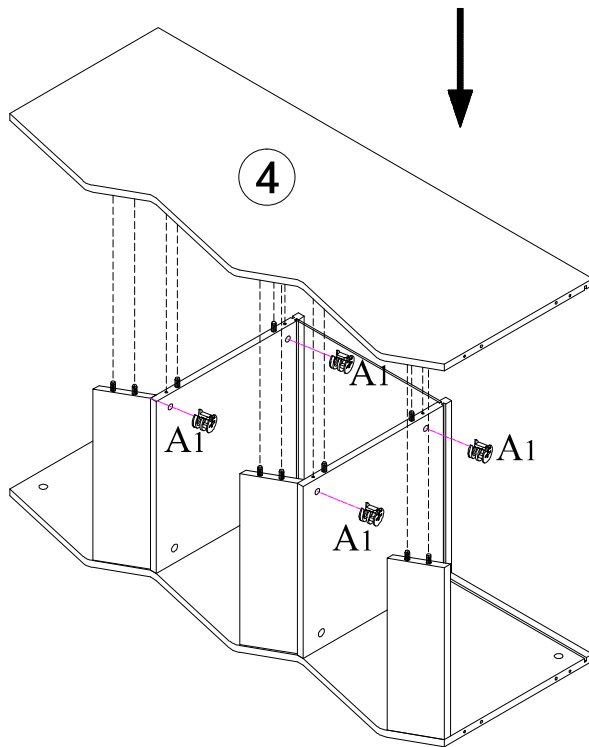

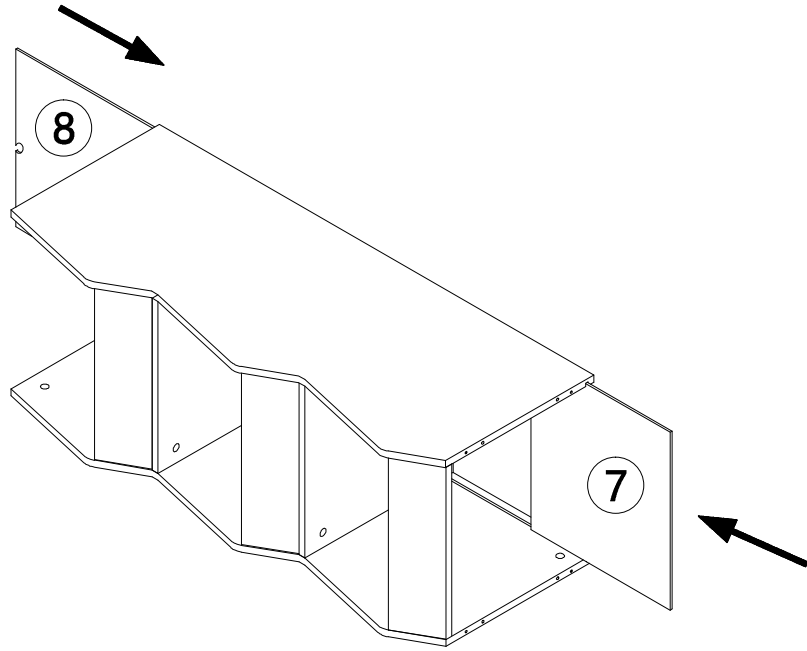

A1
Ø12x10mm
x 4

5

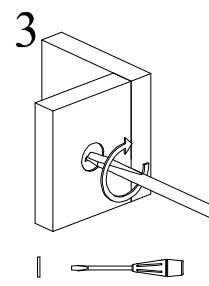
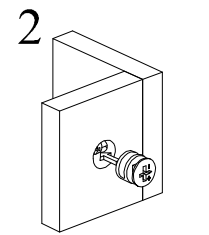
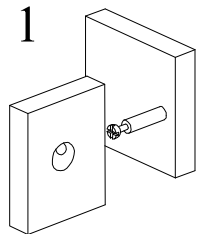
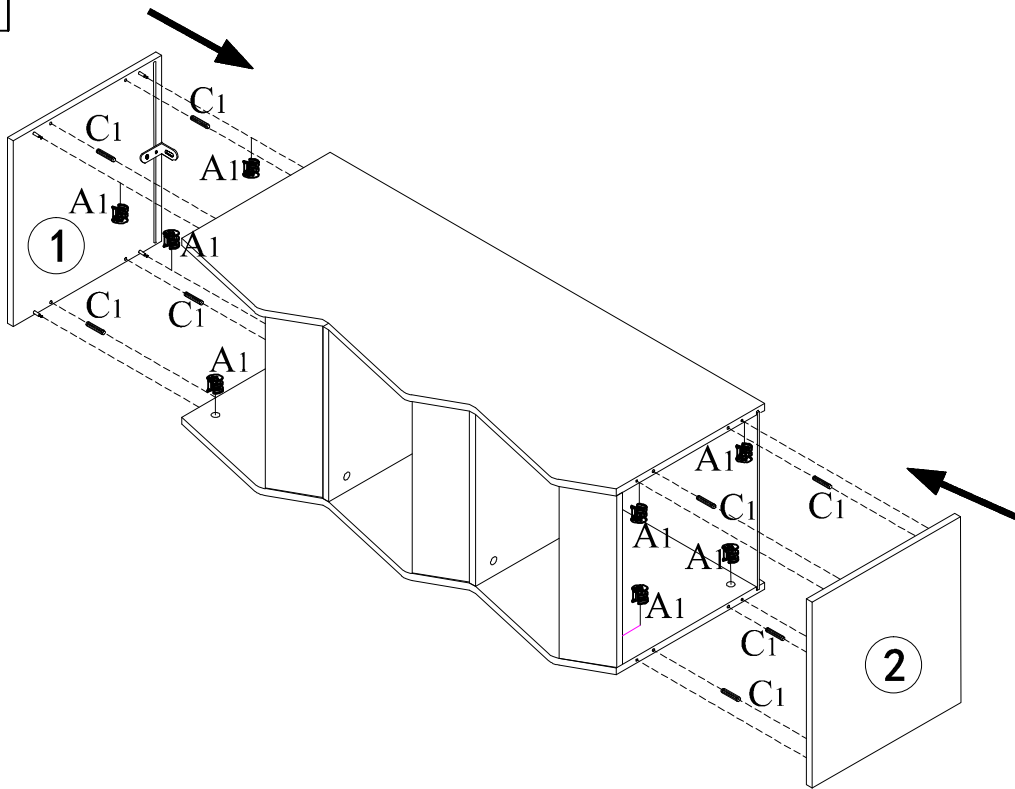

6



A1 
Ø12x10mm
x 8

C1 
Ø6 x 30mm
x8

7

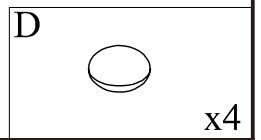
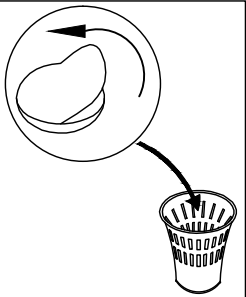
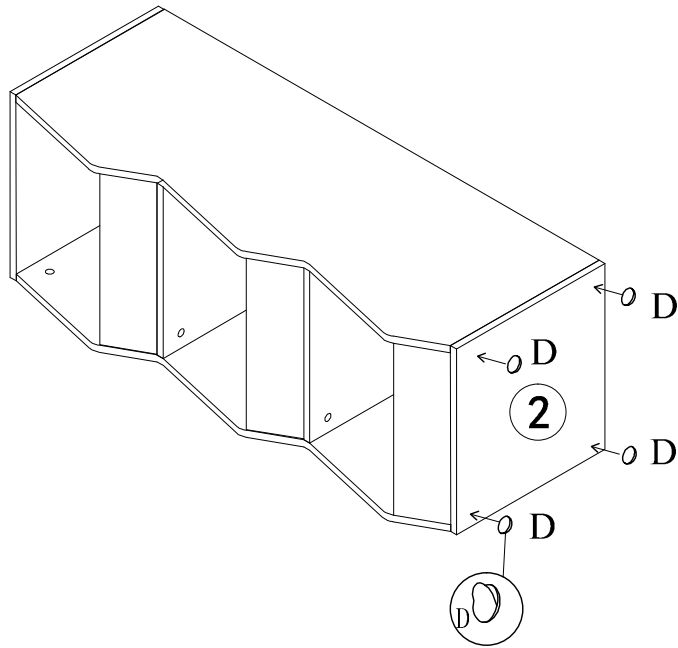

8

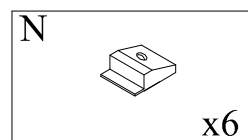
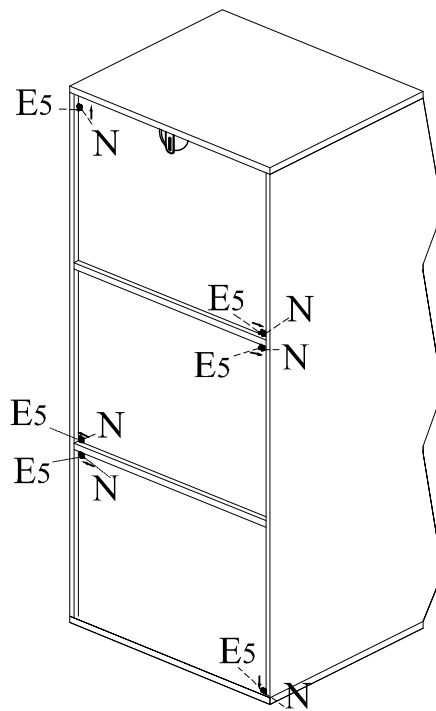
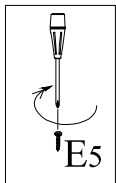

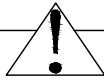
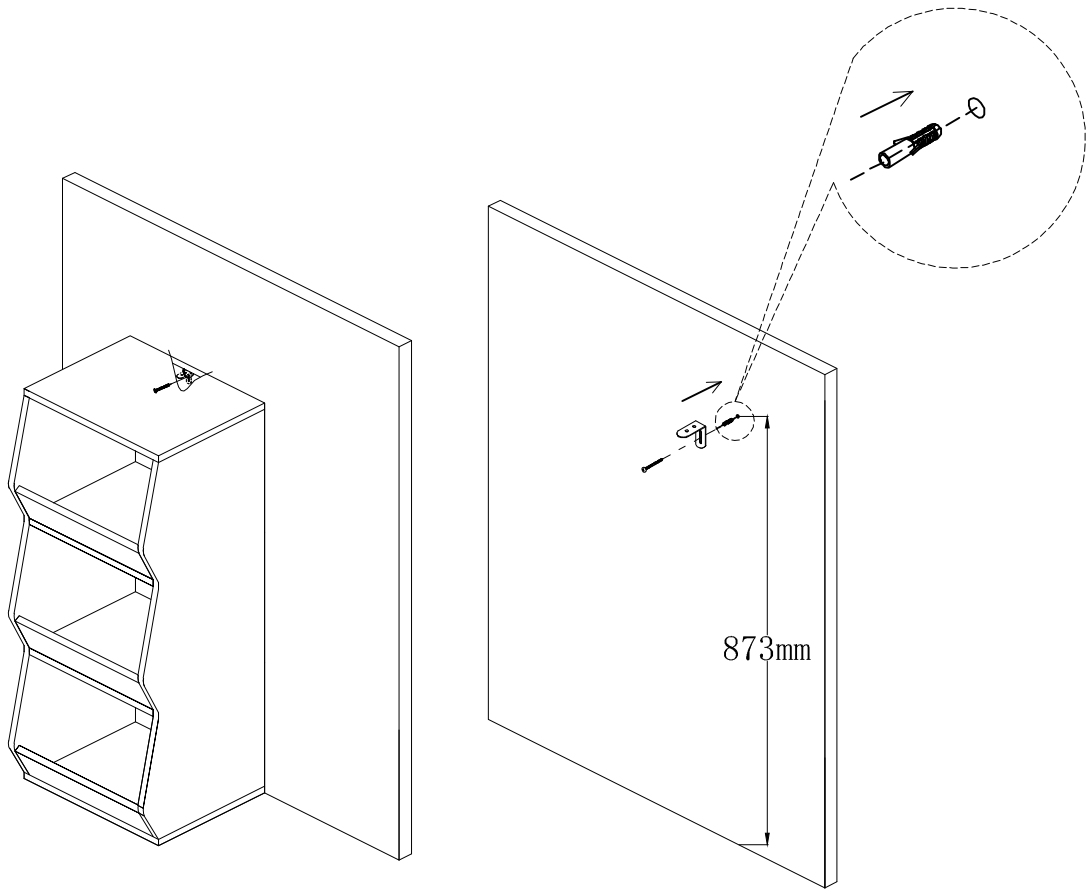

Due to the wide diversity of wall or partition types, we cannot provide you with suitable attachment fixtures. To determine which attachment fixtures to use, you will need to identify the type of wall to which you will be fixing this product. Here are some examples of attachment fixtures recommended for :

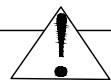

BLIND WALLS

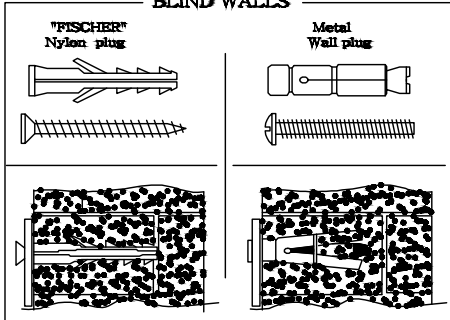

STUDDED WALLS

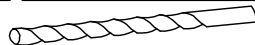
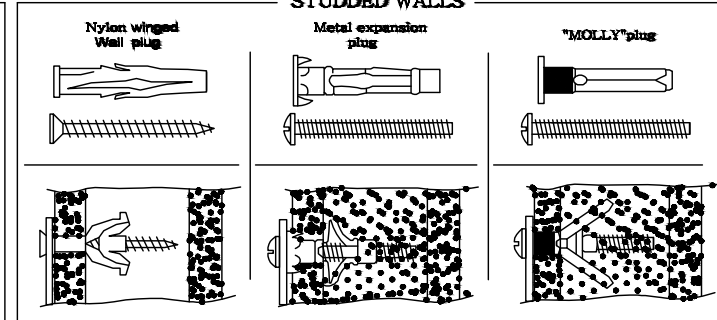

Use a drill bit that is compatible in size with the hardware used and the type of wall

Carton	Reference No.	Quantity
1/1	1	1
1/1	2	1
1/1	3	1
1/1	4	1
1/1	5	3
1/1	6	2
1/1	7	2
1/1	8	1
1/1	Accessories	1