

Storage Shed Owner Manual & Assemble Guide

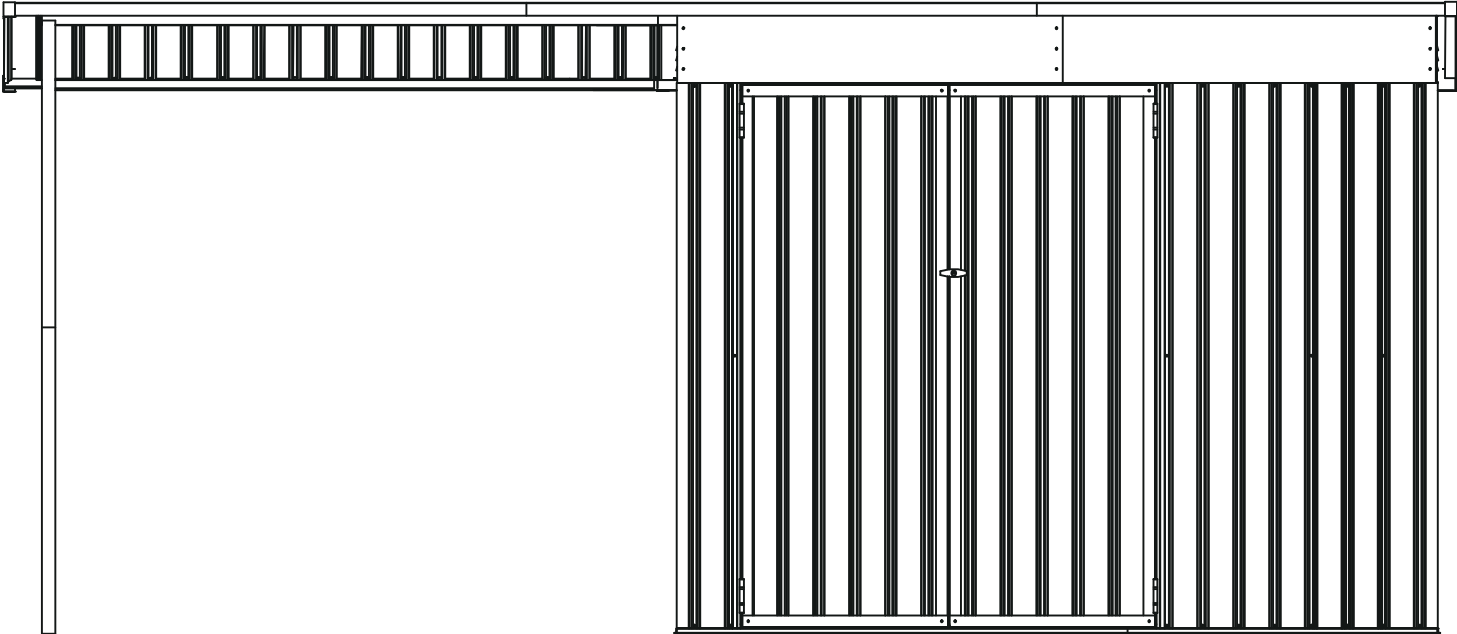

Customer Service:



If you have any problem, please contact us through the online platform.

Shed Size

Shed Overall Size:L167.7*W46.16*H72.83

All parts are packed in two boxes, please note that refer to the parts list to check if all parts are received.

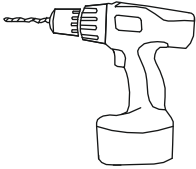
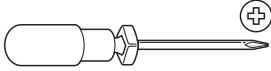
Please prepare below tools before installation. (Not Included)

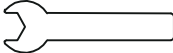
 Electric Screwdriver	 + Manual Screwdriver	 Ladder
Package included Tools	 Gloves x 1Pair	 Spanner x 1

ATTENTION

Care **MUST** be taken when handling various pieces of your building since many contain sharp edges.

Do NOT attempt to assemble your building before double checking that you have all parts indicated in the parts lists. Any building left partially assembled may be seriously damaged by even light winds.

Do NOT attempt to assemble your building on a windy day, the large panels can catch the wind like a “sail”, making construction difficult and unsafe. **Watch the weather closely.** Keep children and pets away from the worksite during construction and until the building is completely assembled. This will help avoid distractions and any accidents which may occur. Never concentrate your weight on the roof of the building.

Before assembling any parts, your base should be constructed and an anchoring system should be ready to use. Your building must be anchored to prevent wind damage.

ASSEMBLY

The best location is a level area with good drainage.

Allow enough space outside the building to be able to access the roof with a ladder.

USE TEAMWORK: Two or more people are required to assemble your building.

CARE & MAINTENANCE

Do NOT use power washing to clean your shed.





Combustibles and corrosives must be stored in air tight containers designed for chemical and/or combustible storage.

Rust Protection Precautions

Avoid nicking or scraping the coating surface, inside and out.

















PLEASE KEEP THIS INSTRUCTION FOR FUTURE REFERENCE.







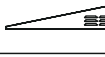









Part List A

PART	NO.	QTY.
	Y48-8	2
	Y48-8M	8
	W5	9
	W3	4









PART	NO.	QTY.
	W5-K	2
	W2-HL	1
	W2-HR	1









Part List B

PART	NO.	QTY.
	W3-C	3
	K414W3-C	1
	K48-1L	2
	K48-1R	2
	C46-2	2
	C46-3	2
	K414-4L	1
	K414-4M	1
	K414-4R	1
	K48-5L	1
	K48-5R	1
	K414-8LY	1
	K414-8RY	1
	K414-6L	1
	K414-6R	1
	C48-7L	1

PART	NO.	QTY.
	DBA	4
	UA	2
	K414-11	1
	K414-12	1
	K414-13	1
	K310-14	2
	K310-15	1
	K310-16	1
	K310-10	2
	K310-17	2
	K310-18	2
	C14	1
	K310-19	1
	DC	2
	GC	4
	T-F	4

Part List B

	C48-7R	1
	K1014-9L	2
	K1014-9M	2
	K1014-9R	2
	Y48-9	2
	DA	2
	DLA	1
	DRA	1
	DDA	4

	C2	4
	F1	366
	F2	35
	F3	32
	V2	126
	DH	4
	GL	1
	M20	1
	ST	2

NOTE: This is **not the beginning** of the installation steps; it is merely to indicate where each component will be installed.

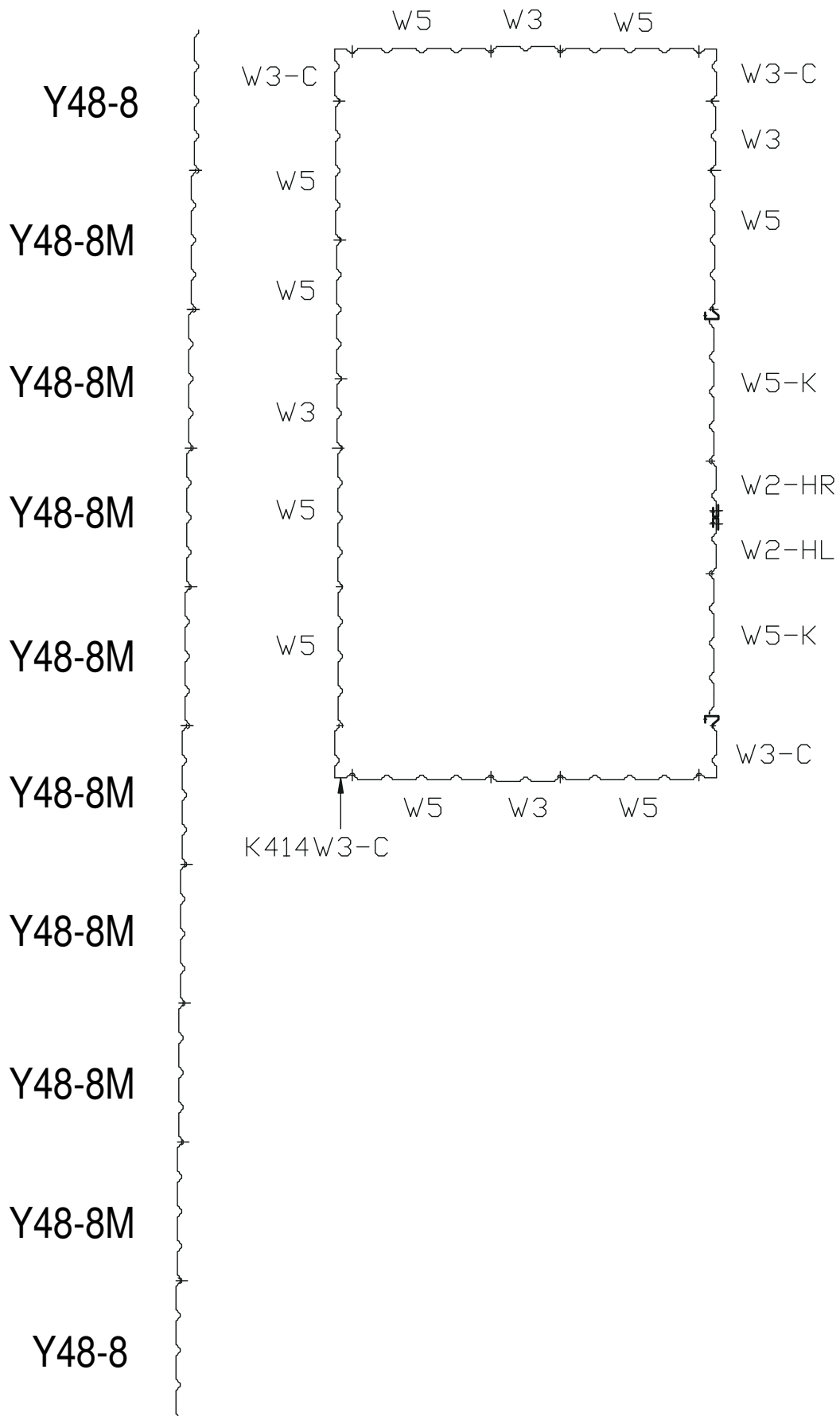



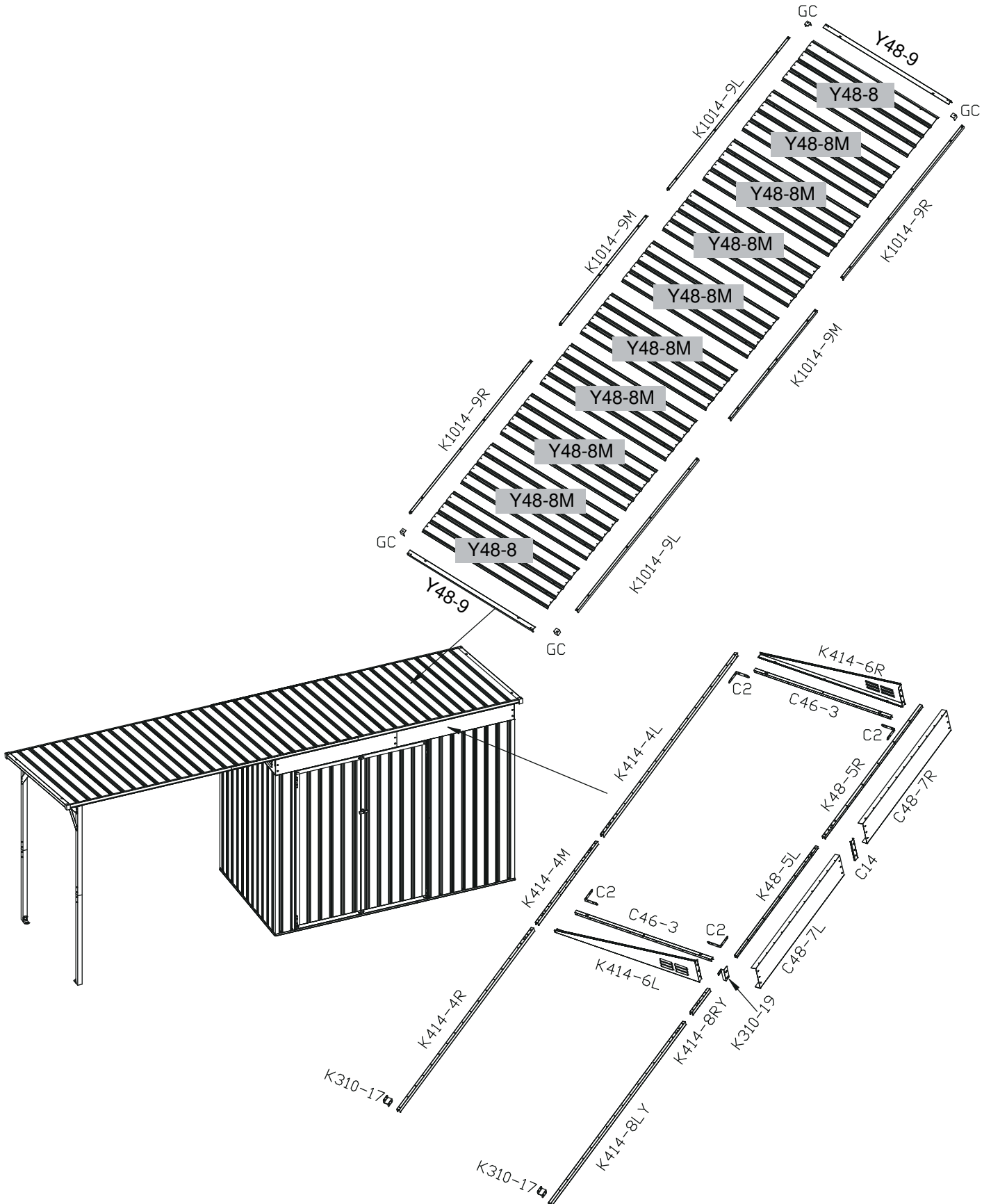

Part List

NOTE: This is **not the beginning** of the installation steps; it is merely to indicate where each component will be installed.



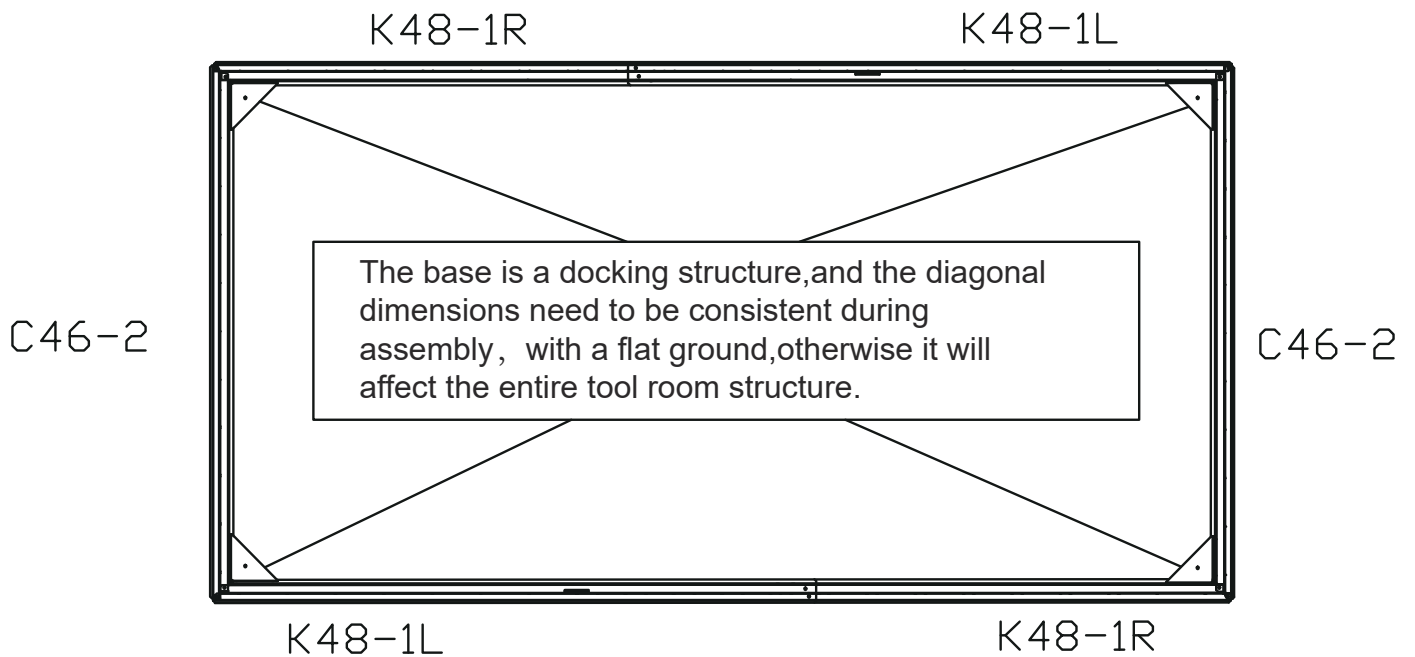
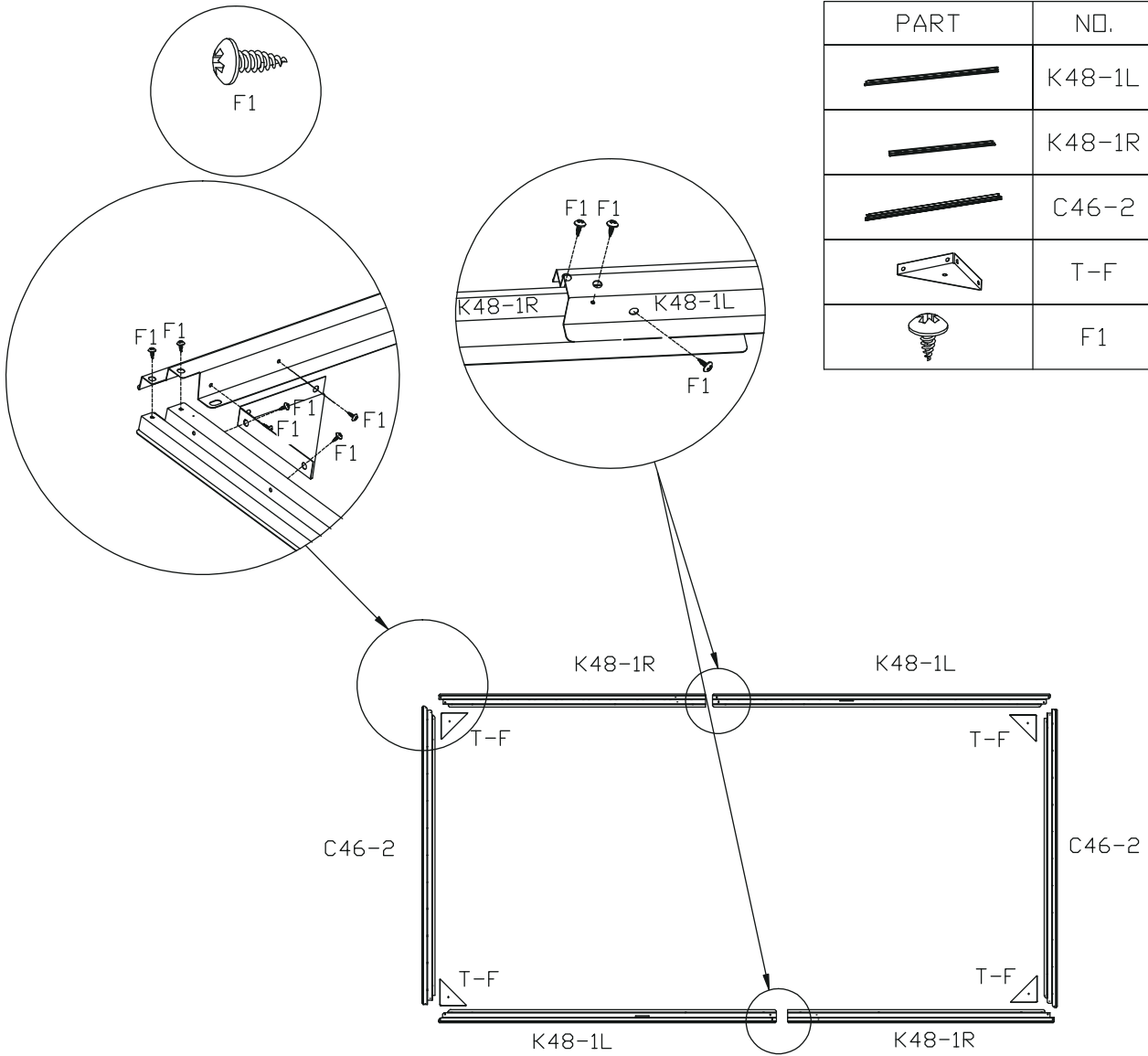

Shed Base Assemble

PART	NO.	QTY.
	K48-1L	2
	K48-1R	2
	C46-2	2
	T-F	4
	F1	30





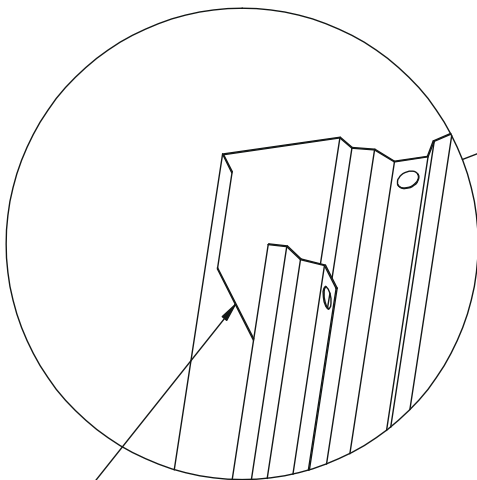
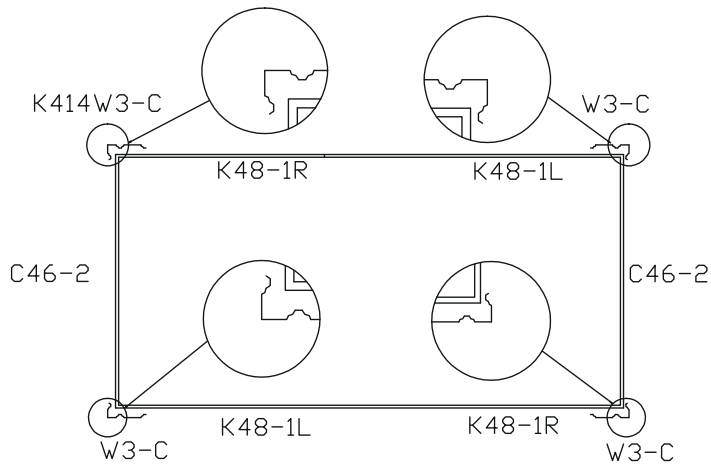

Side Panel Assemble

PART	NO.	QTY.
	W3-C	3
	K414W3-C	1
	F1	4

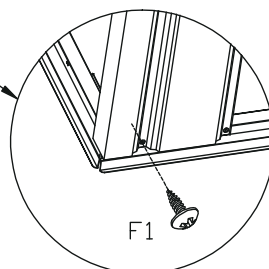
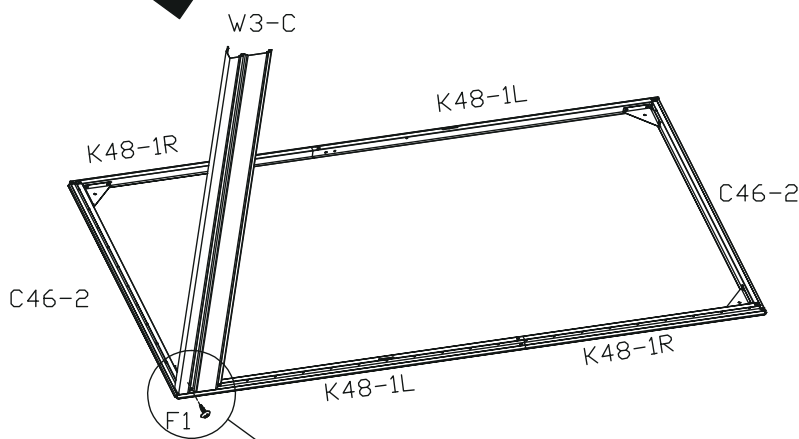
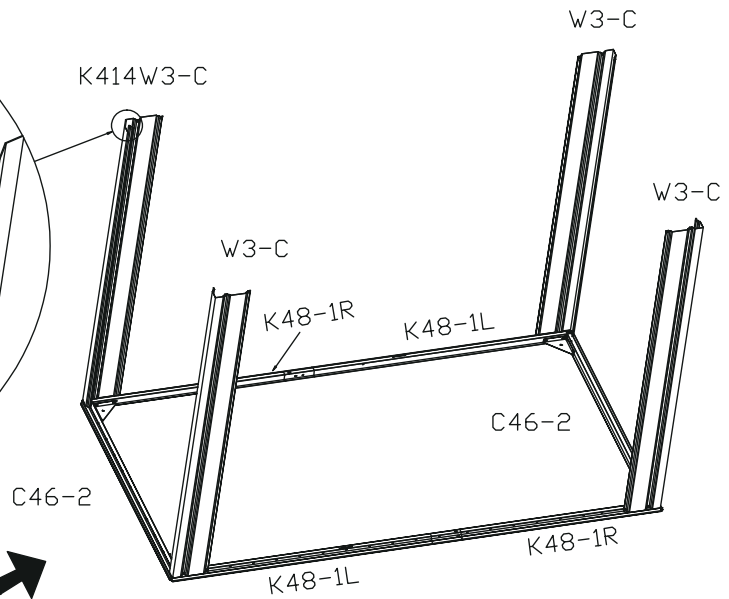



Please note the direction of the gap.



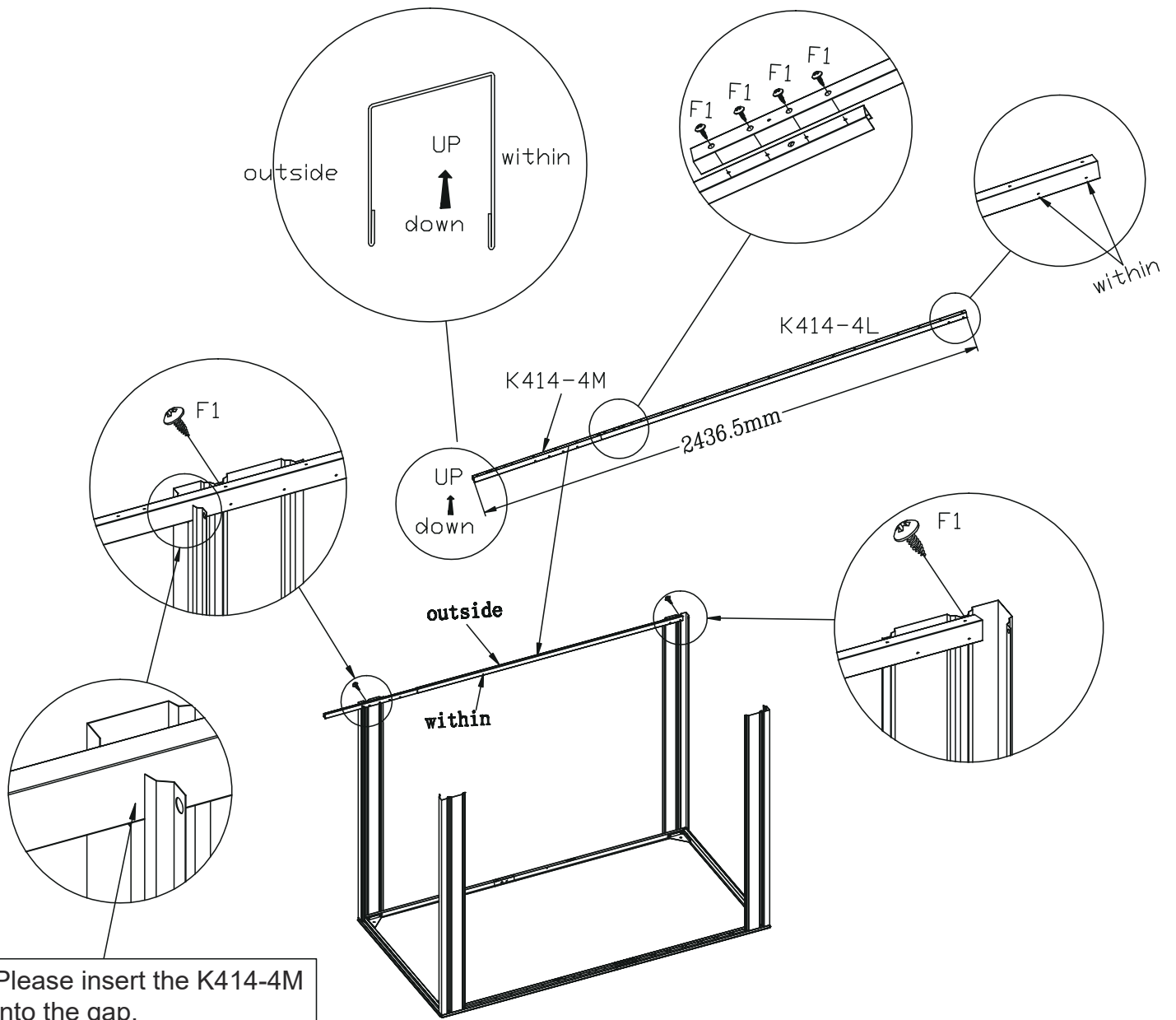



PART	NO.	QTY.
	K414-4L	1
	K414-4M	1
	F1	6

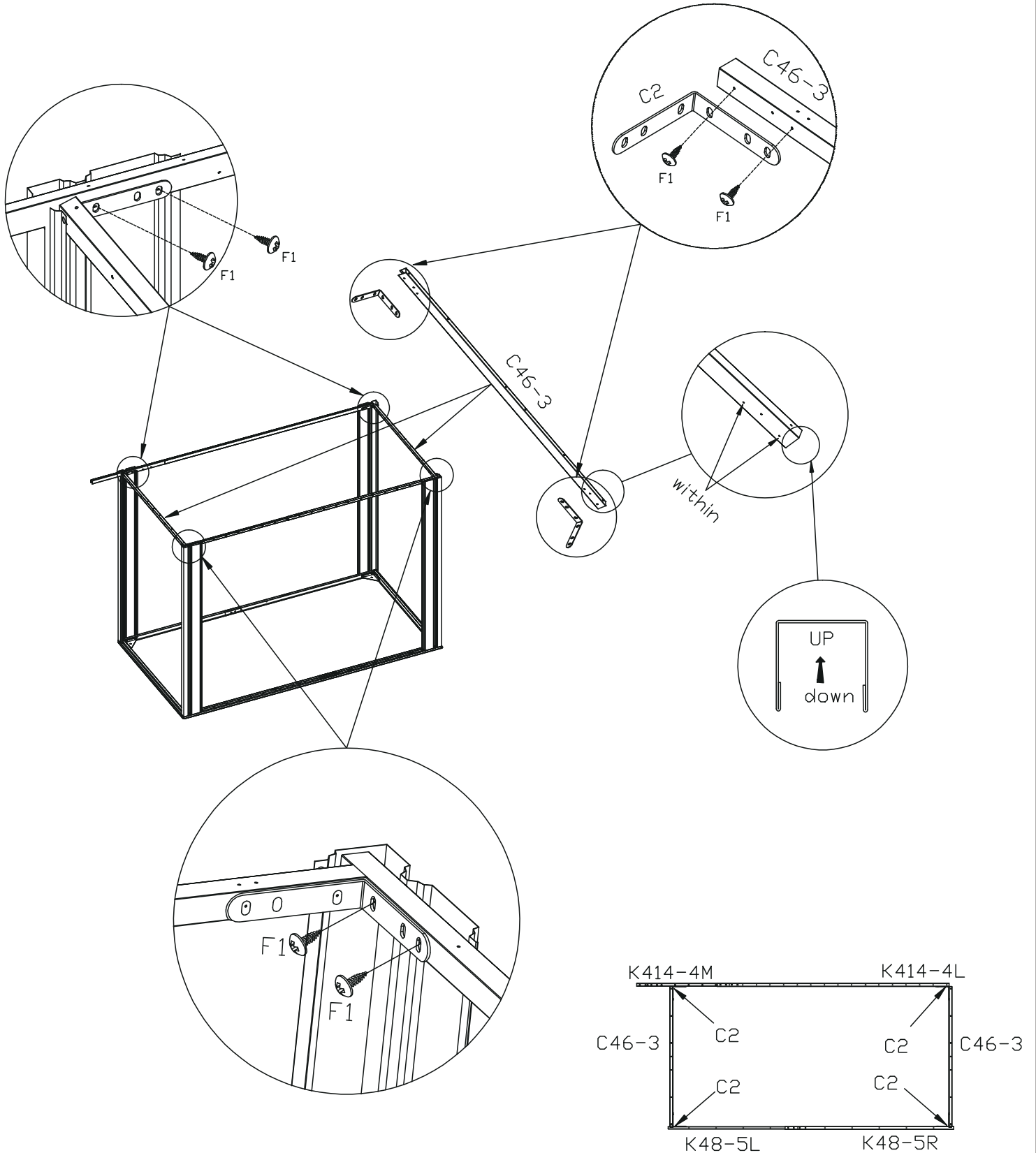





PART	NO.	QTY.
	C46-3	2
	F1	16
	C2	4

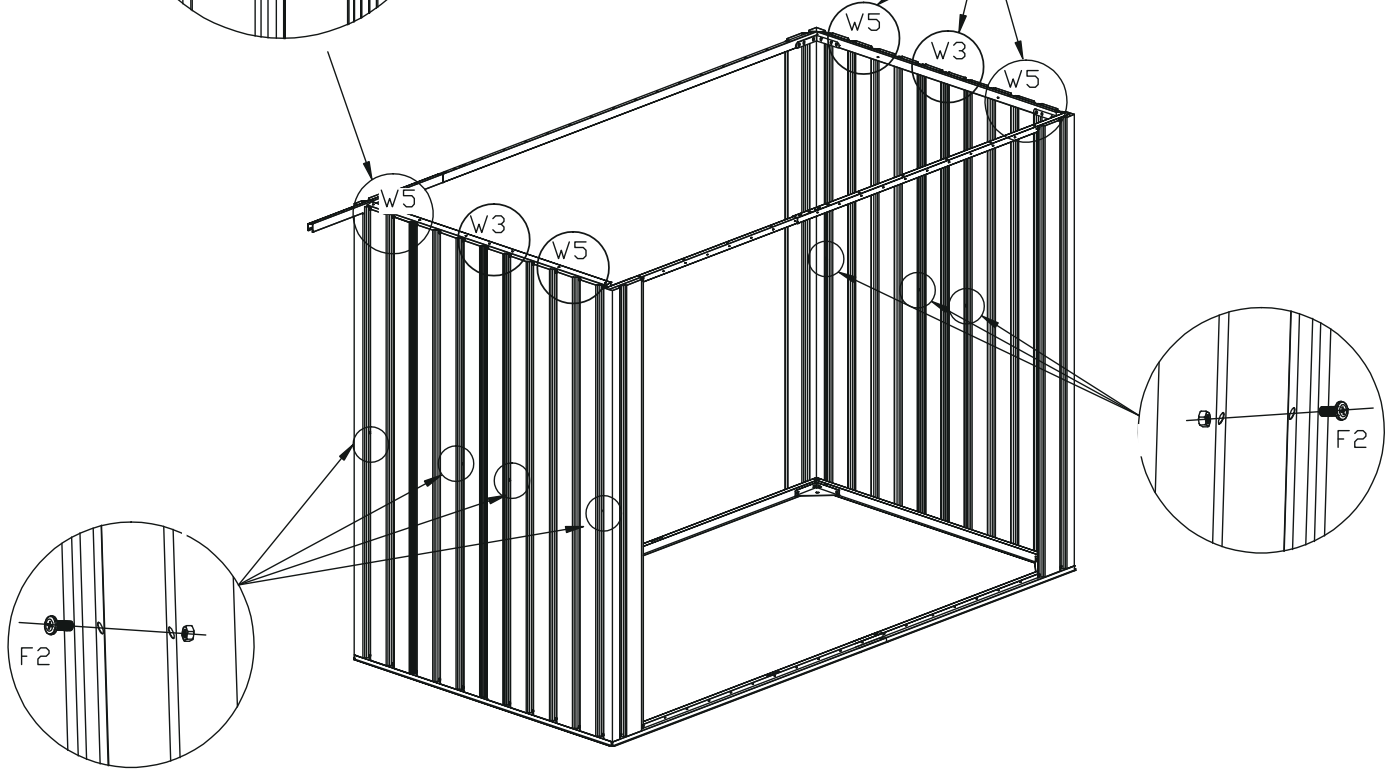
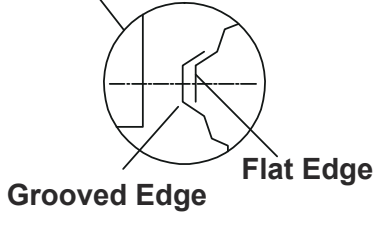
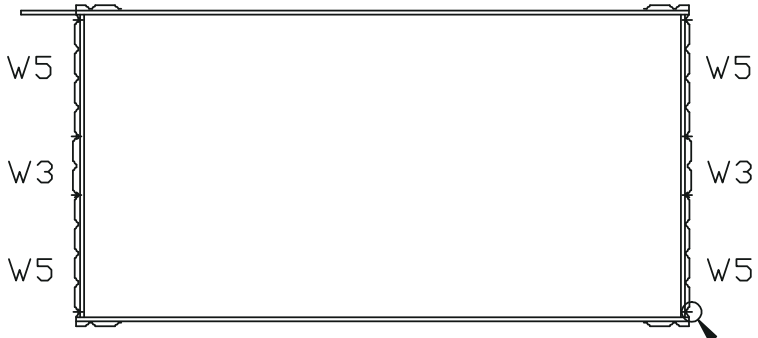





PART	NO.	QTY.
	W5	4
	W3	2
	F1	44
	F2	8

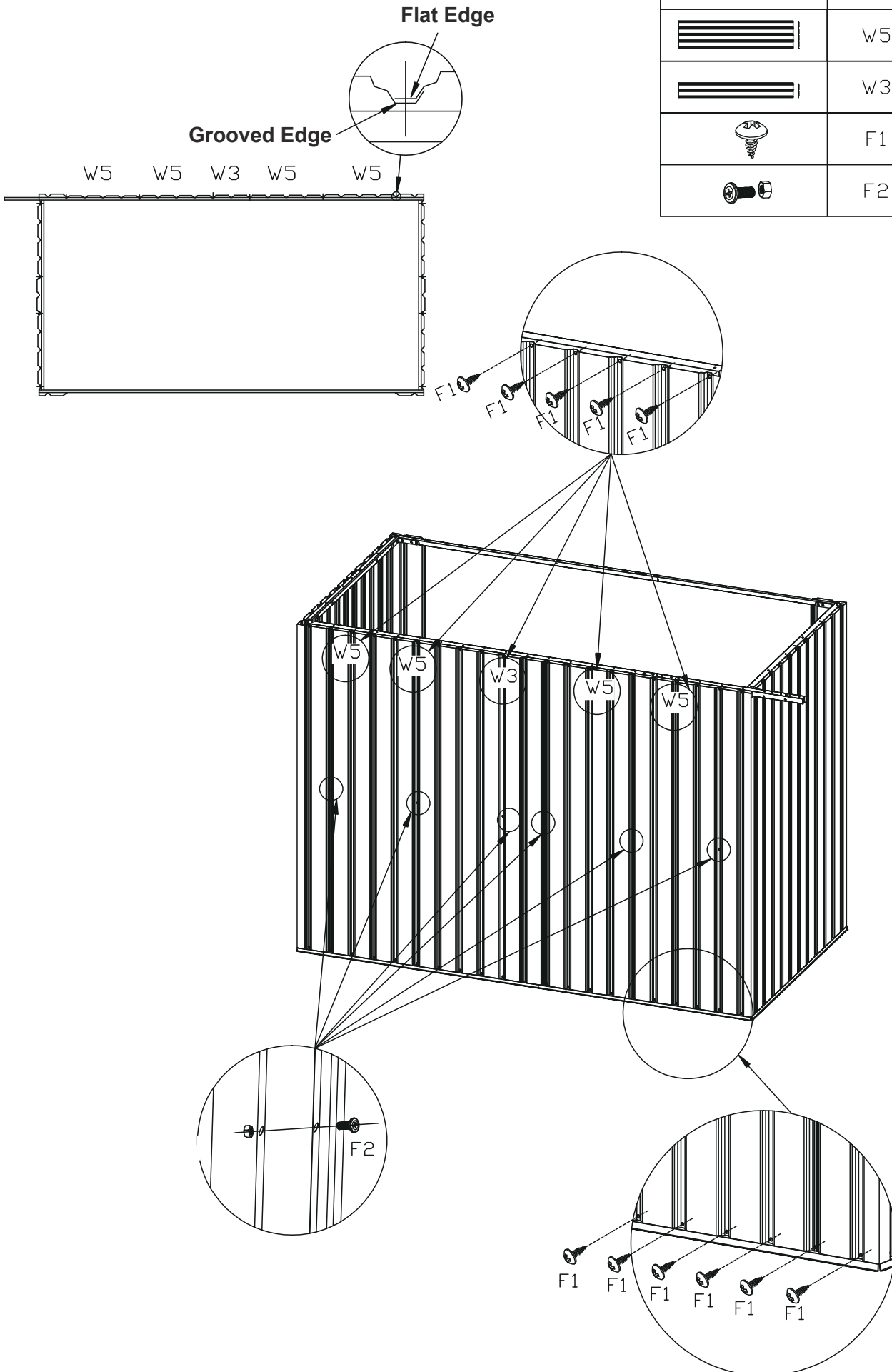

Top Panel Assemble

PART	NO.	QTY.
	W5	4
	W3	1
	F1	38
	F2	6



PART	NO.	QTY.
	W5	1
	W3	1
	F1	12
	F2	2

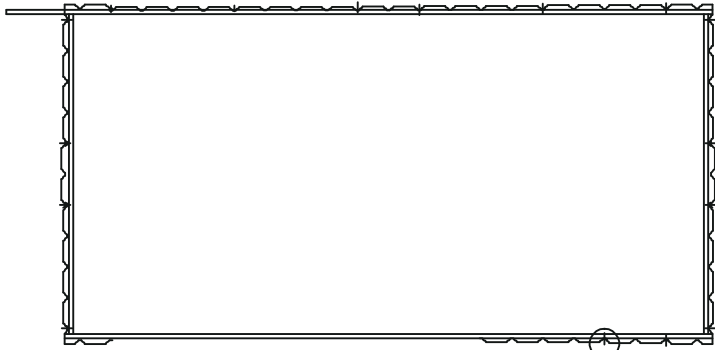

W5 W3

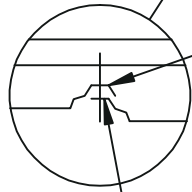

Grooved Edge

Flat Edge

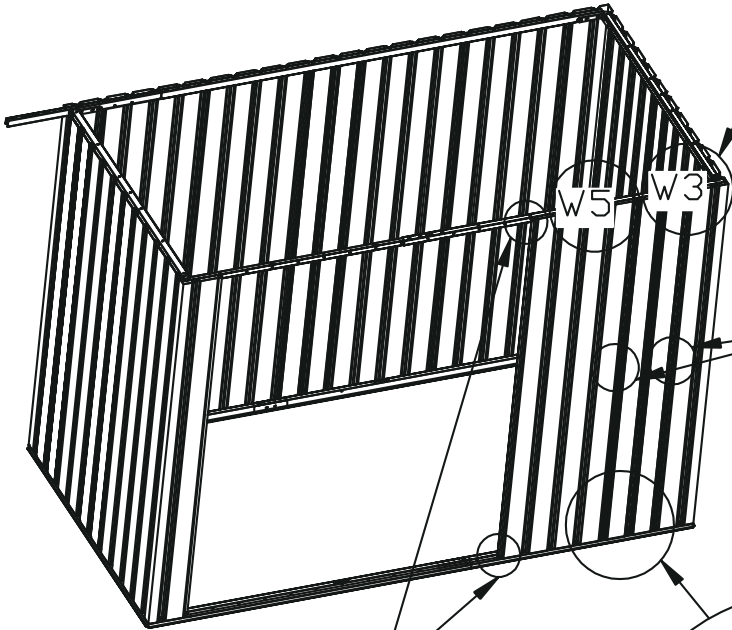
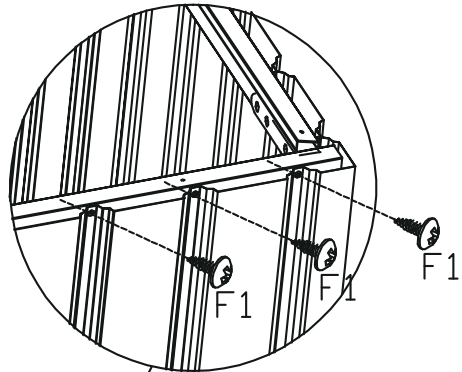

W5 W3

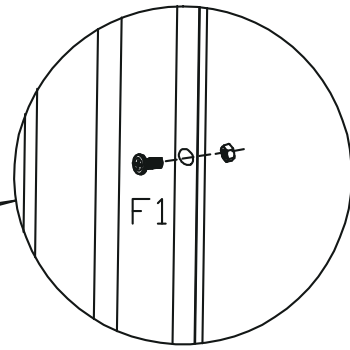

F1

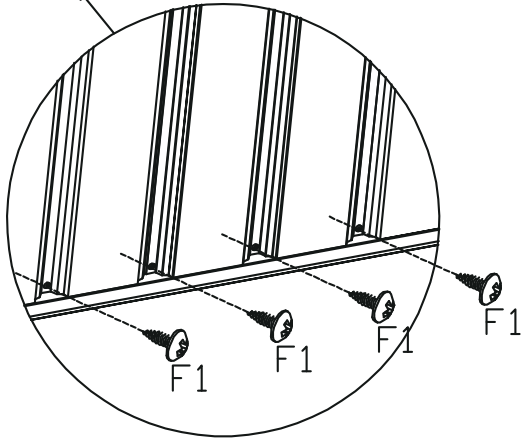
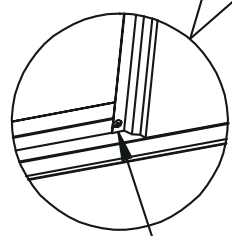

F1



F1

F1

F1

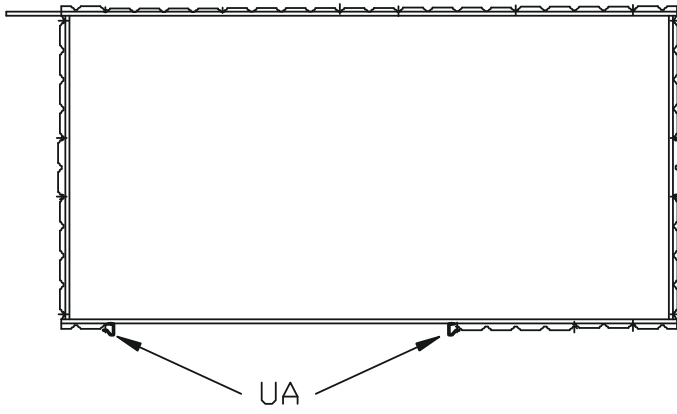
Note: Screws are not required for installation at this time. Please install the UA accessories first before the screws.



PART	NO.	QTY.
	UA	2
	F1	8
	F2	2

2. Fit the notch above tube UA into K48-5R

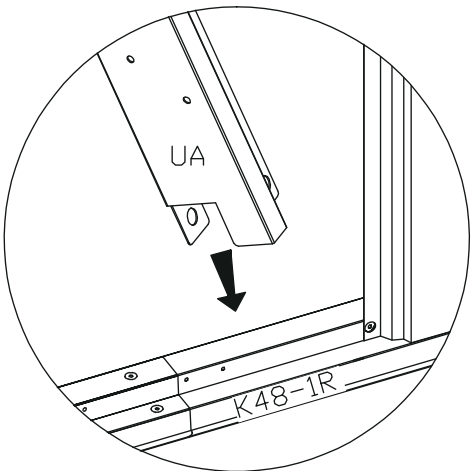
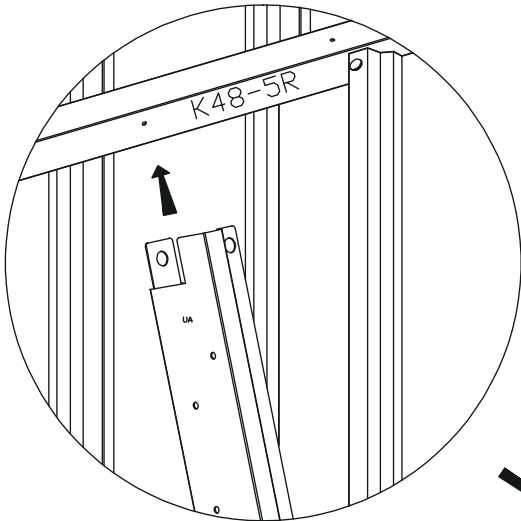

1. Fit the notch of tube UA into the base K48-1R.

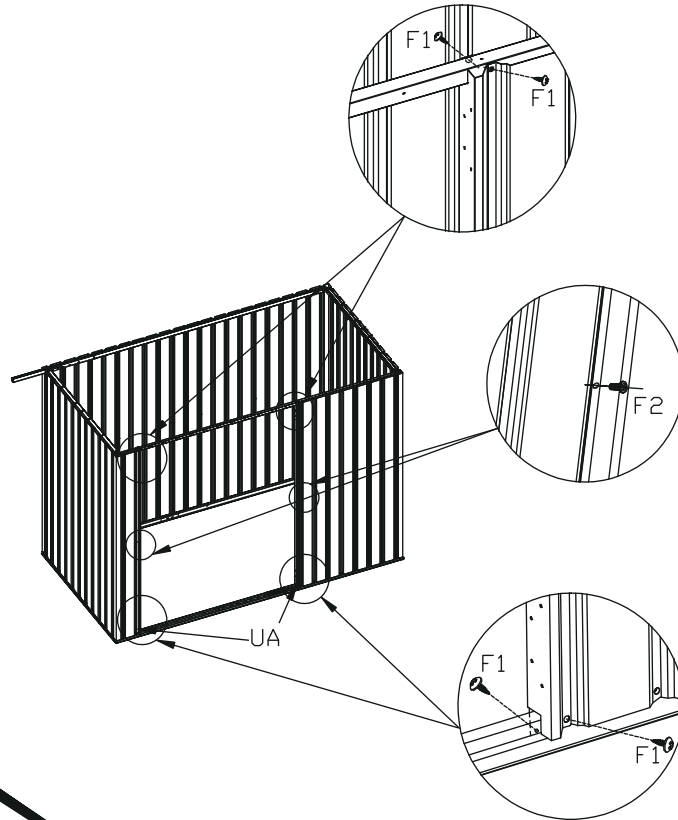



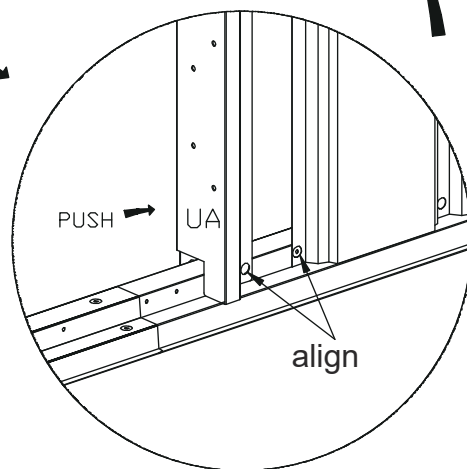



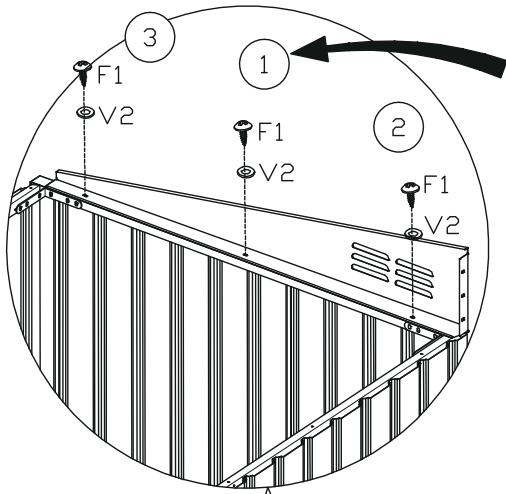

4. Secure with F1 screws.

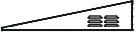

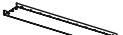
3. Slide UA to align the screws holes of UA and W5.



1. Install the screws in the order of ① to ③, starting with the middle screw to avoid misalignment.

PART	NO.	QTY.
	K414-6L	1
	K414-6R	1
	C48-7L	1
	C48-7R	1
	C14	1
	K310-19	1
	V2	16
	F1	16
	F2	9

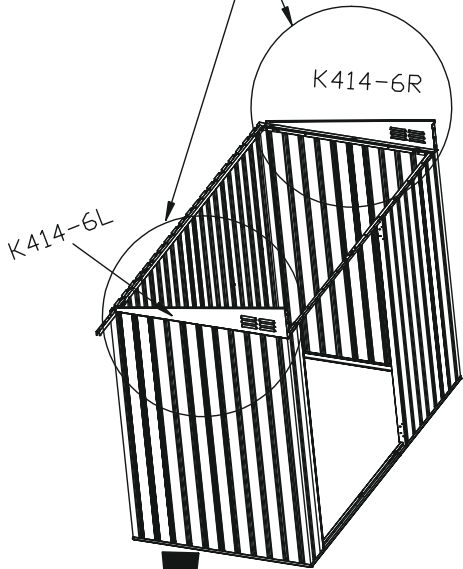



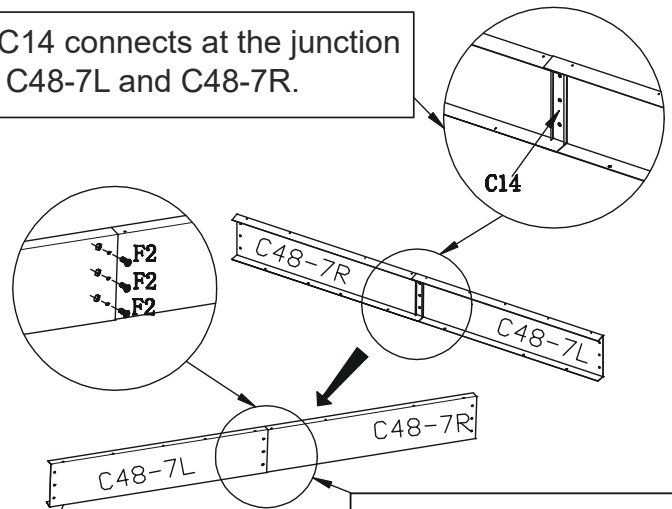

2. C14 connects at the junction of C48-7L and C48-7R.

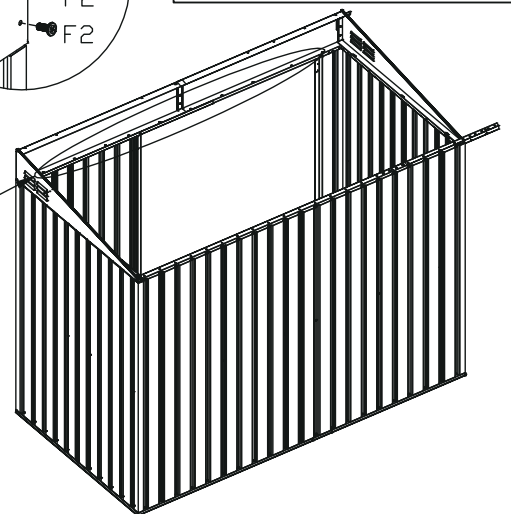
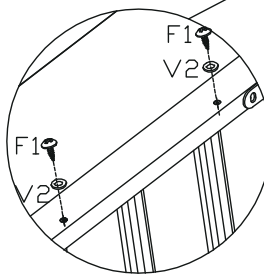
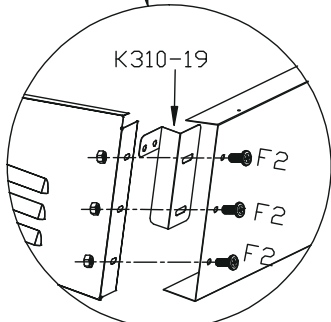
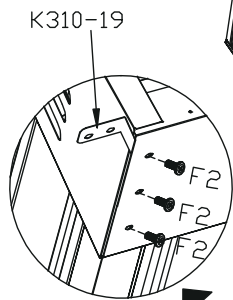
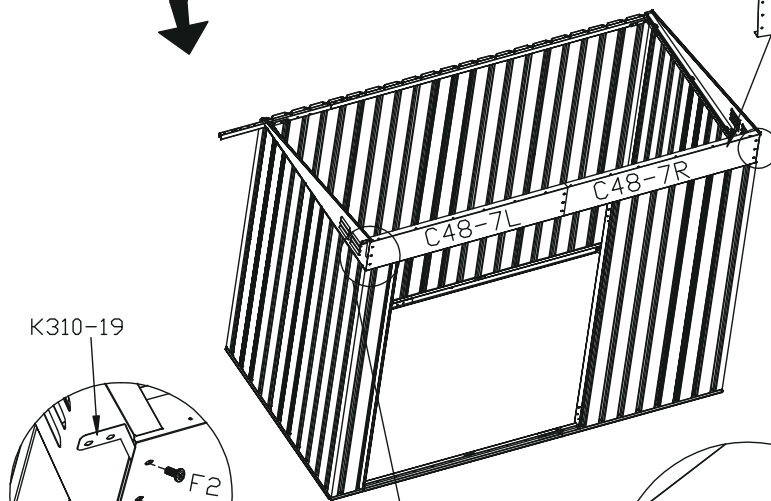





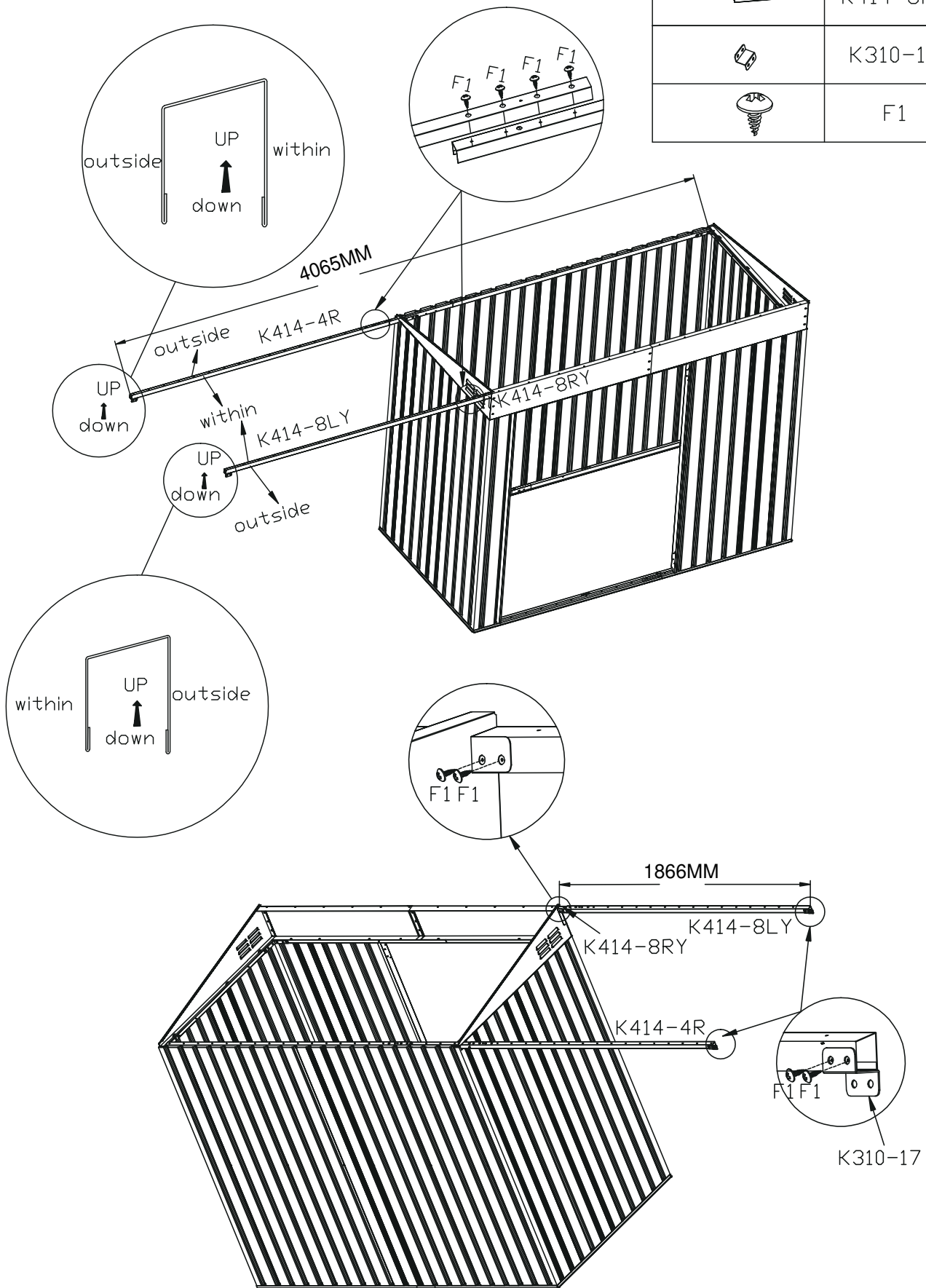

C48-7L is wider, when connecting them, fit C48-7R into it and secure with 3 F2 screws



PART	NO.	QTY.
	K414-4R	1
	K414-8LY	1
	K414-8RY	1
	K310-17	2
	F1	14



PART	NO.	QTY.
	K310-14	2
	K310-15	1
	K310-16	1
	K310-10	2
	K310-18	2
	F1	24

Pay attention to the orientations of 4 holes





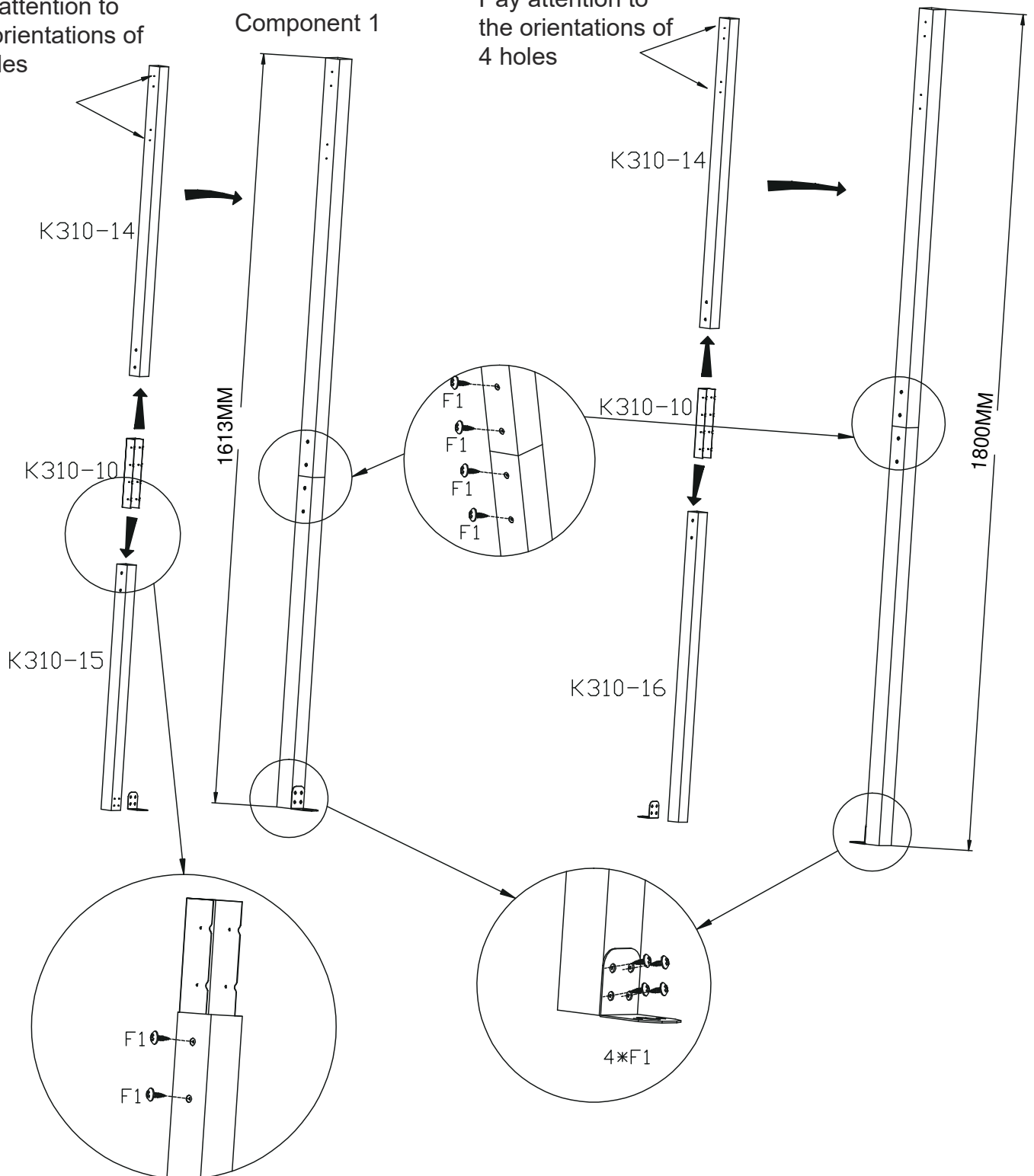

Component 1

Pay attention to the orientations of 4 holes

Component 2



Door Assemble



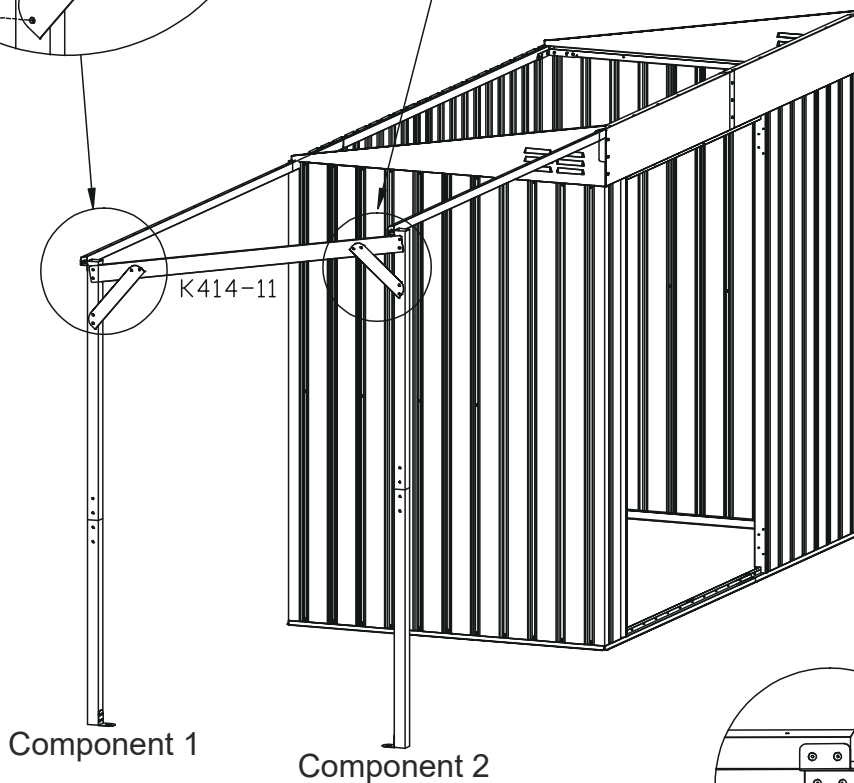
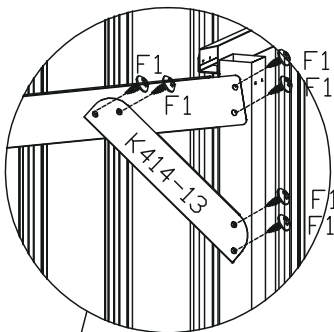
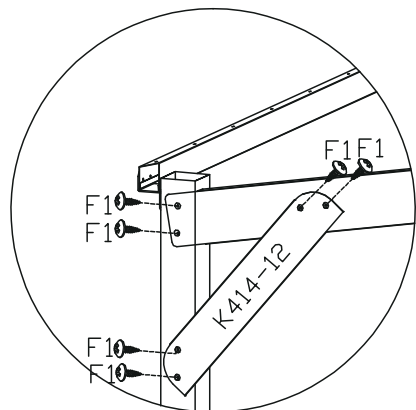

PART	NO.	QTY.
	K414-11	1
	K414-12	1
	K414-13	1
	Component 1	1
	Component 2	1
	F1	16

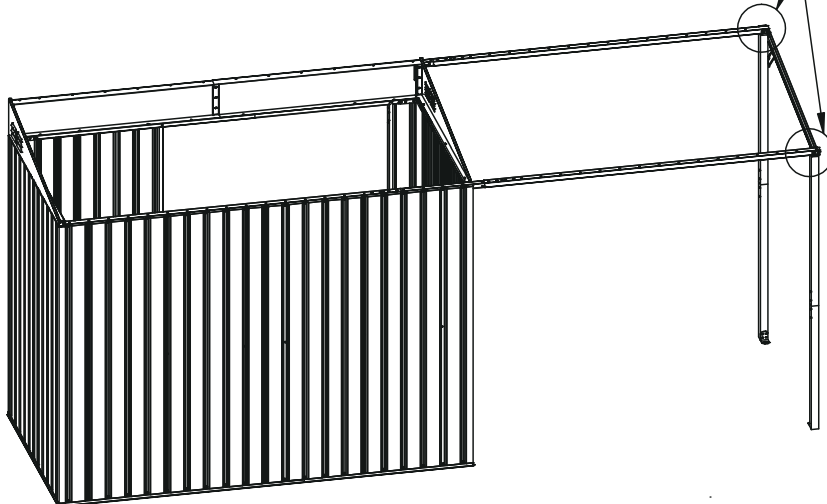
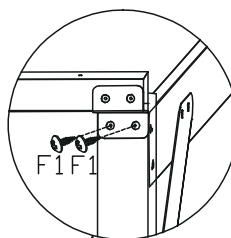

Component 1

Component 2



PART	NO.	QTY.
	Y48-8	2
	Y48-8M	8
	V2	78
	F1	78

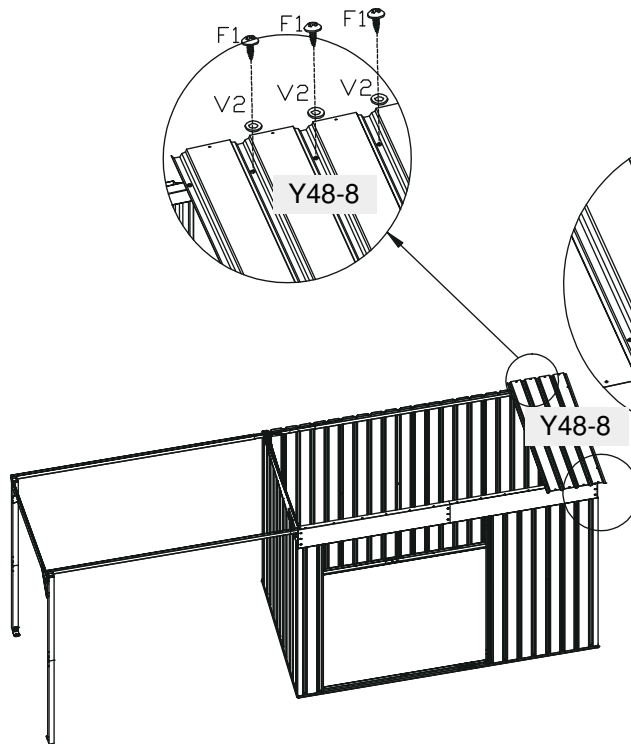

The flat edge with small holes should face outward

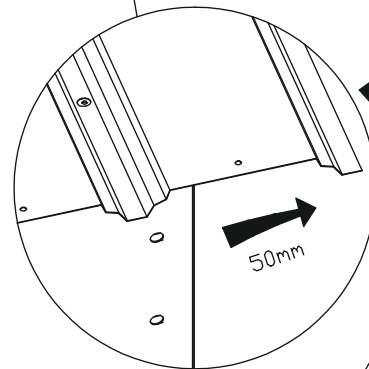



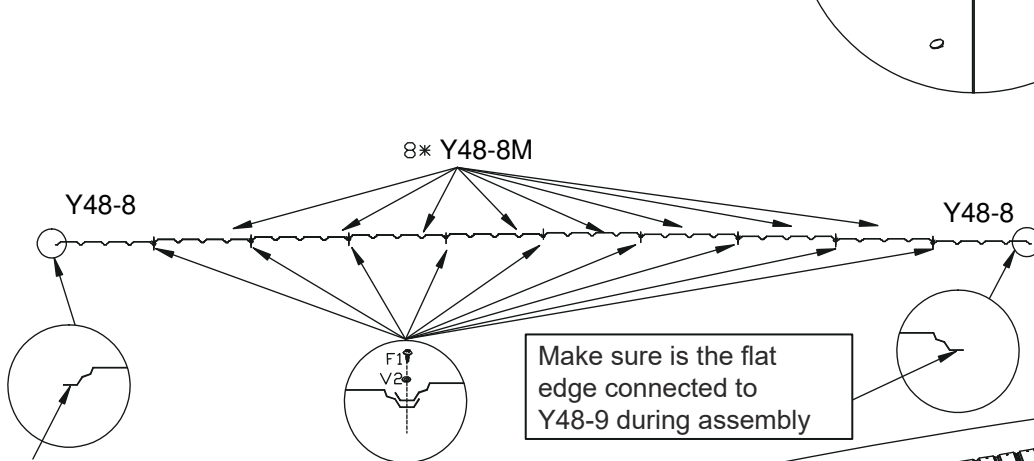



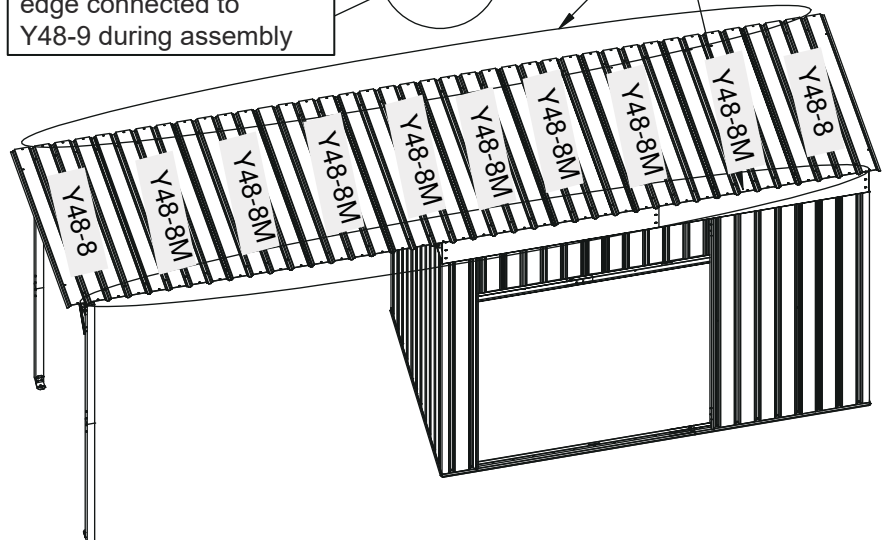
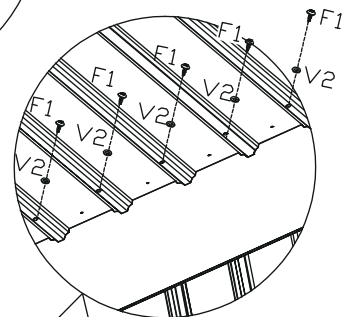

The edge should extend approximately 50 mm outward, as shown







Make sure is the flat edge connected to Y48-9 during assembly

Make sure is the flat edge connected to Y48-9 during assembly

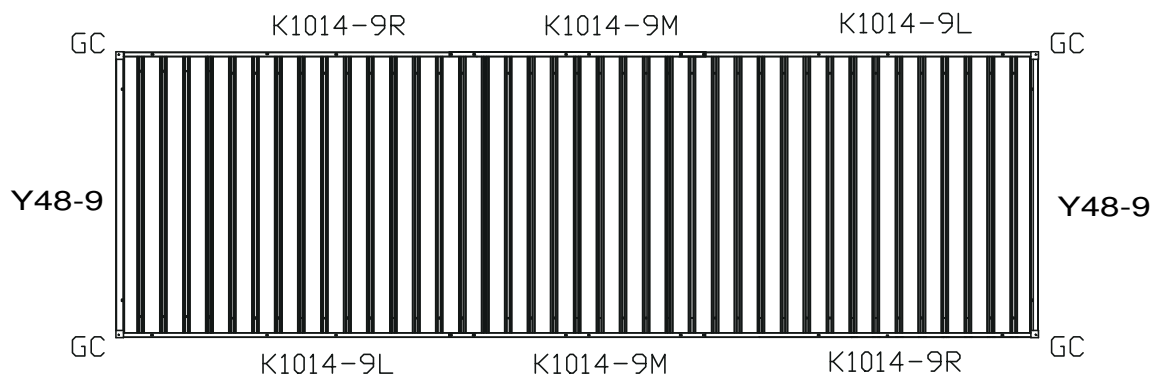
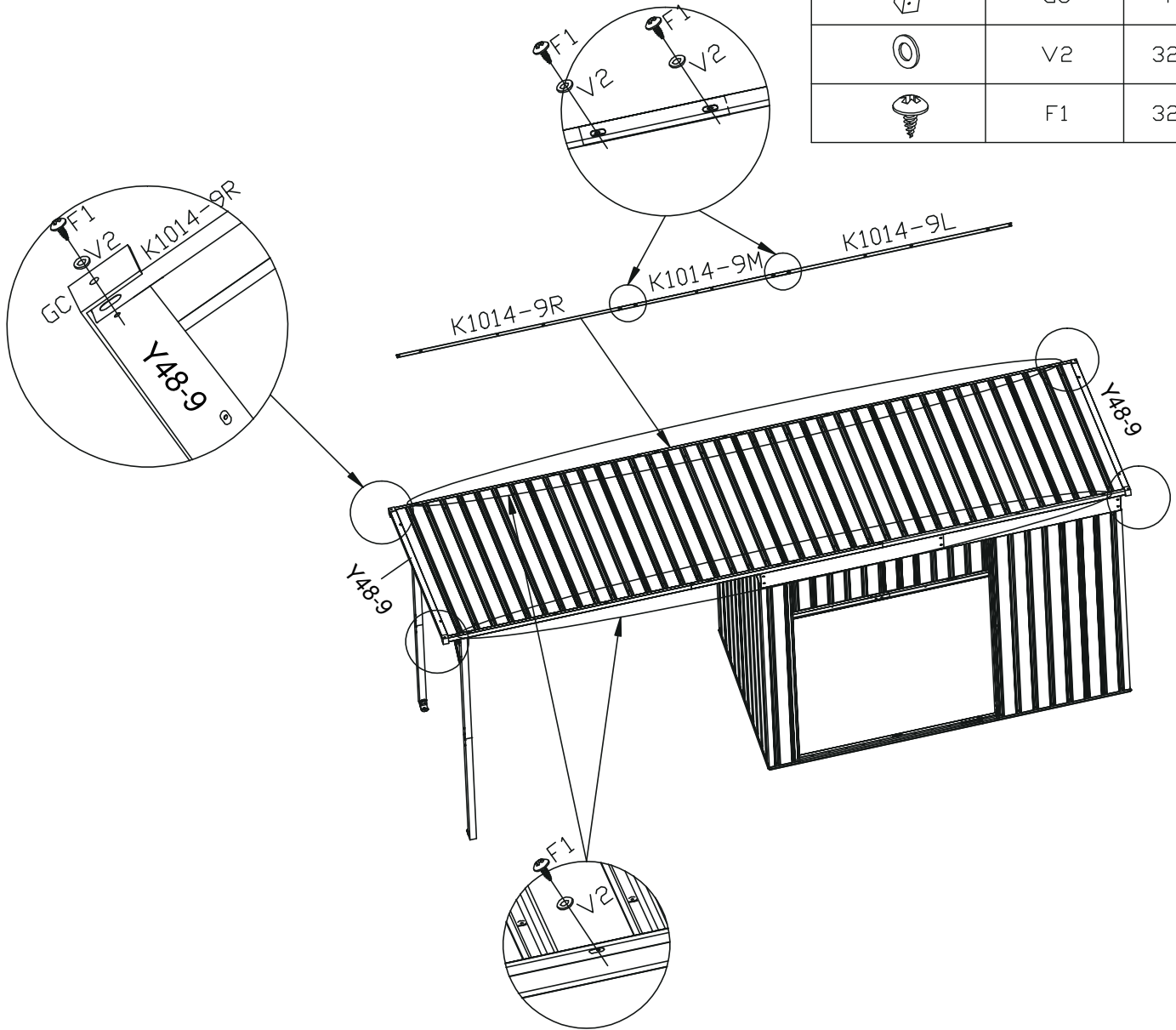





PART	NO.	QTY.
	K1014-9L	2
	K1014-9M	2
	K1014-9R	2
	Y48-9	2
	GC	4
	V2	32
	F1	32

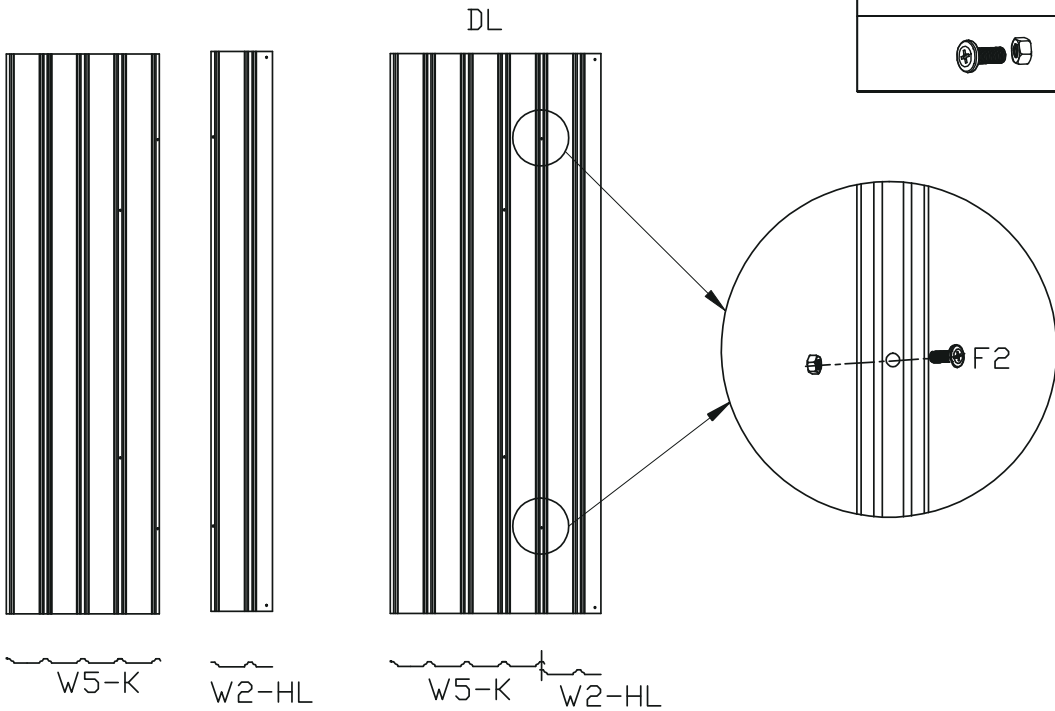



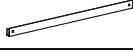
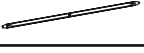

PART	NO.	QTY.
	W5-K	1
	W2-HL	1
	F2	2

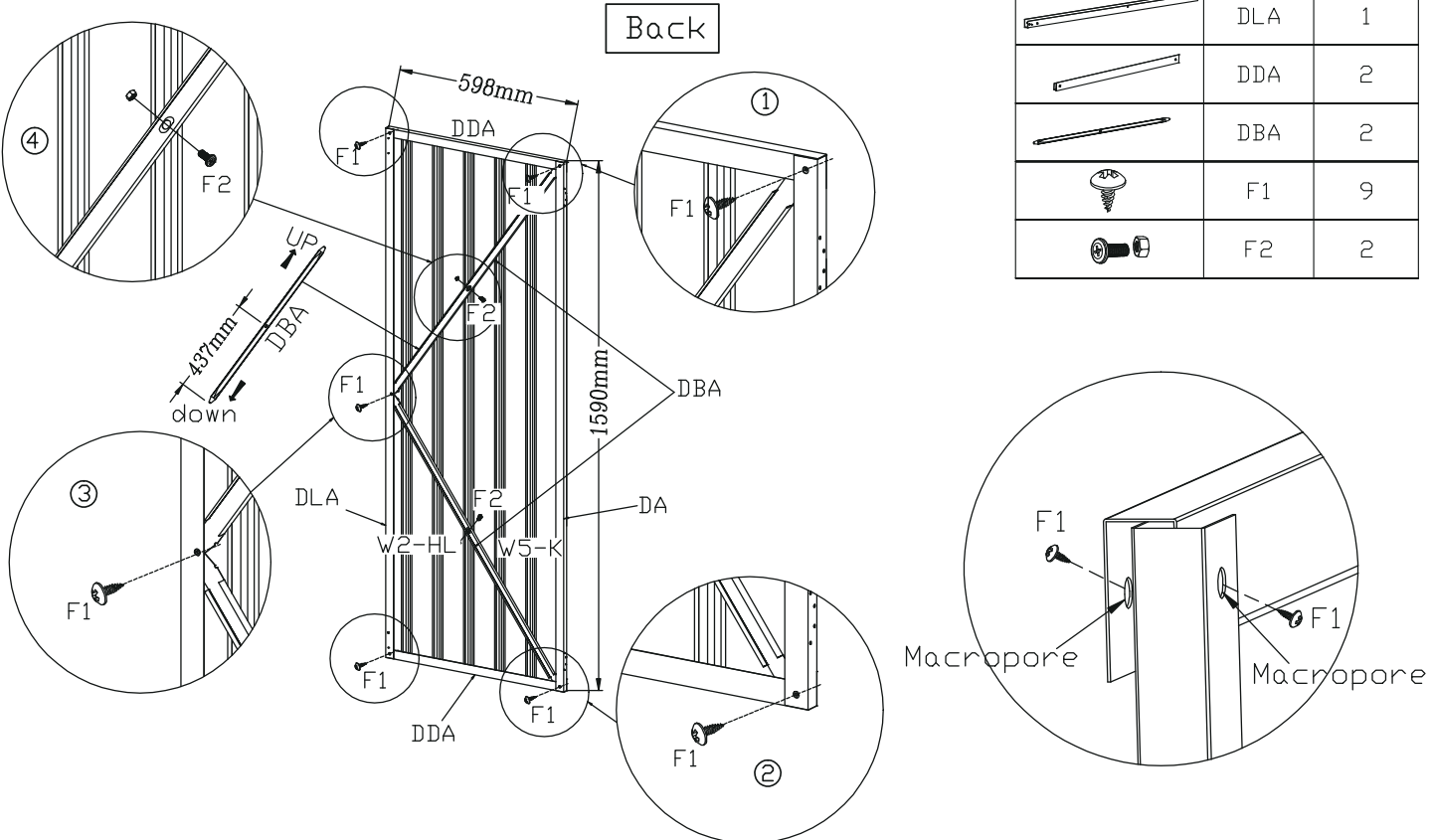

Assemble the left door panel

PART	NO.	QTY.
	DA	1
	DLA	1
	DDA	2
	DBA	2
	F1	9
	F2	2







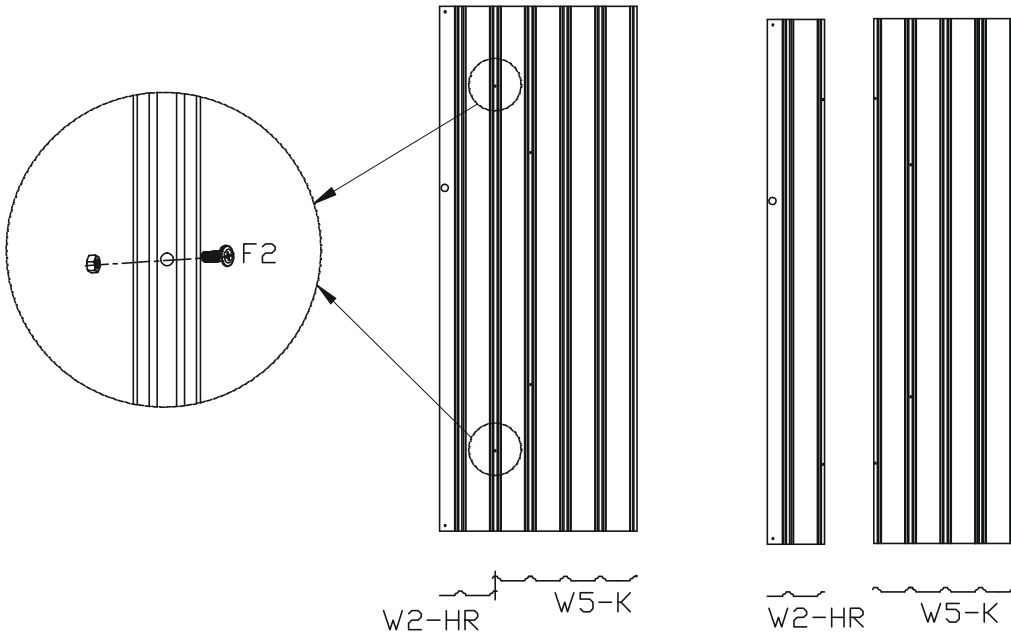

PART	NO.	QTY.
	W5-K	1
	W2-HR	1
	F2	2



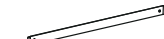

DR



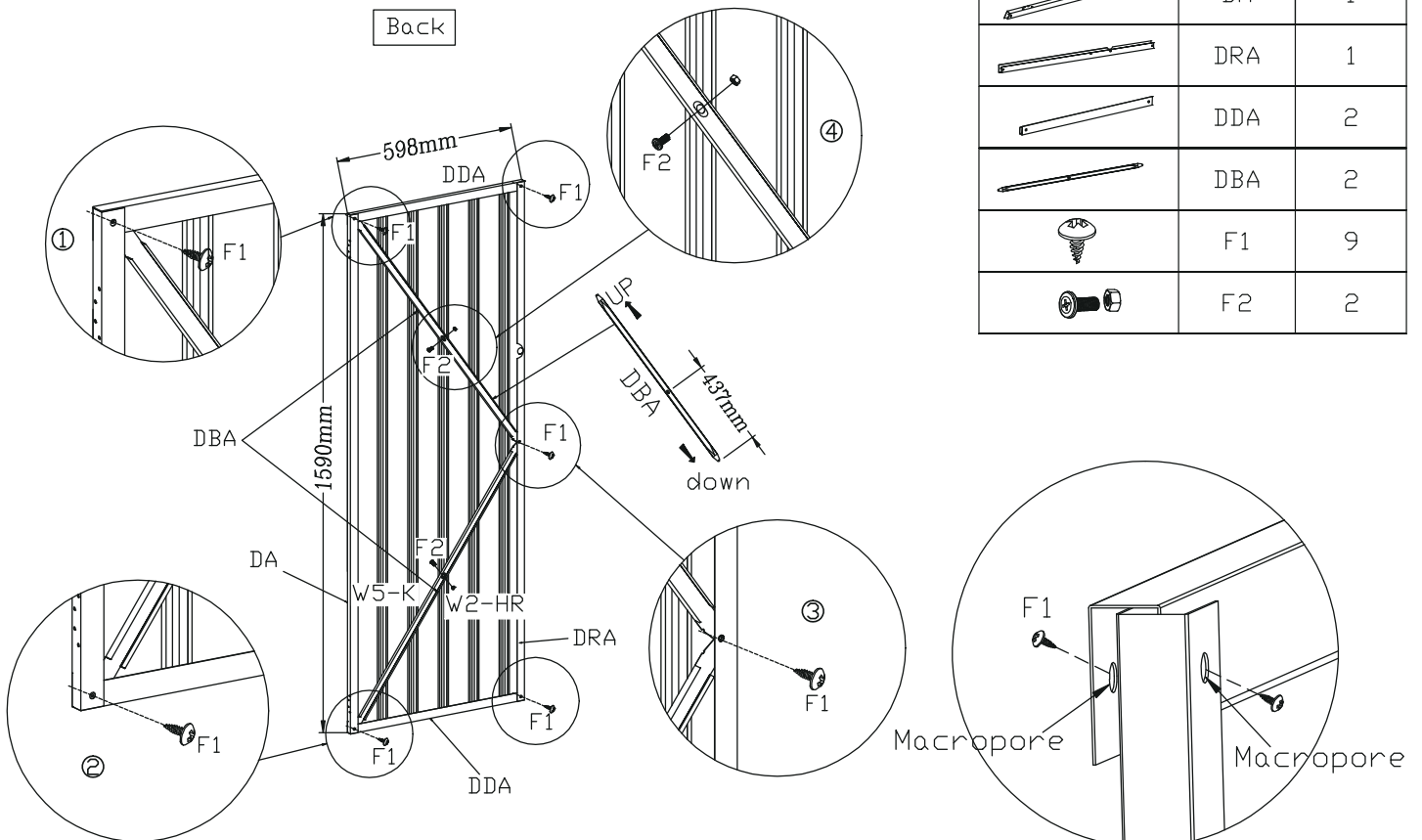



Assemble the right door panel

PART	NO.	QTY.
	DA	1
	DRA	1
	DDA	2
	DBA	2
	F1	9
	F2	2

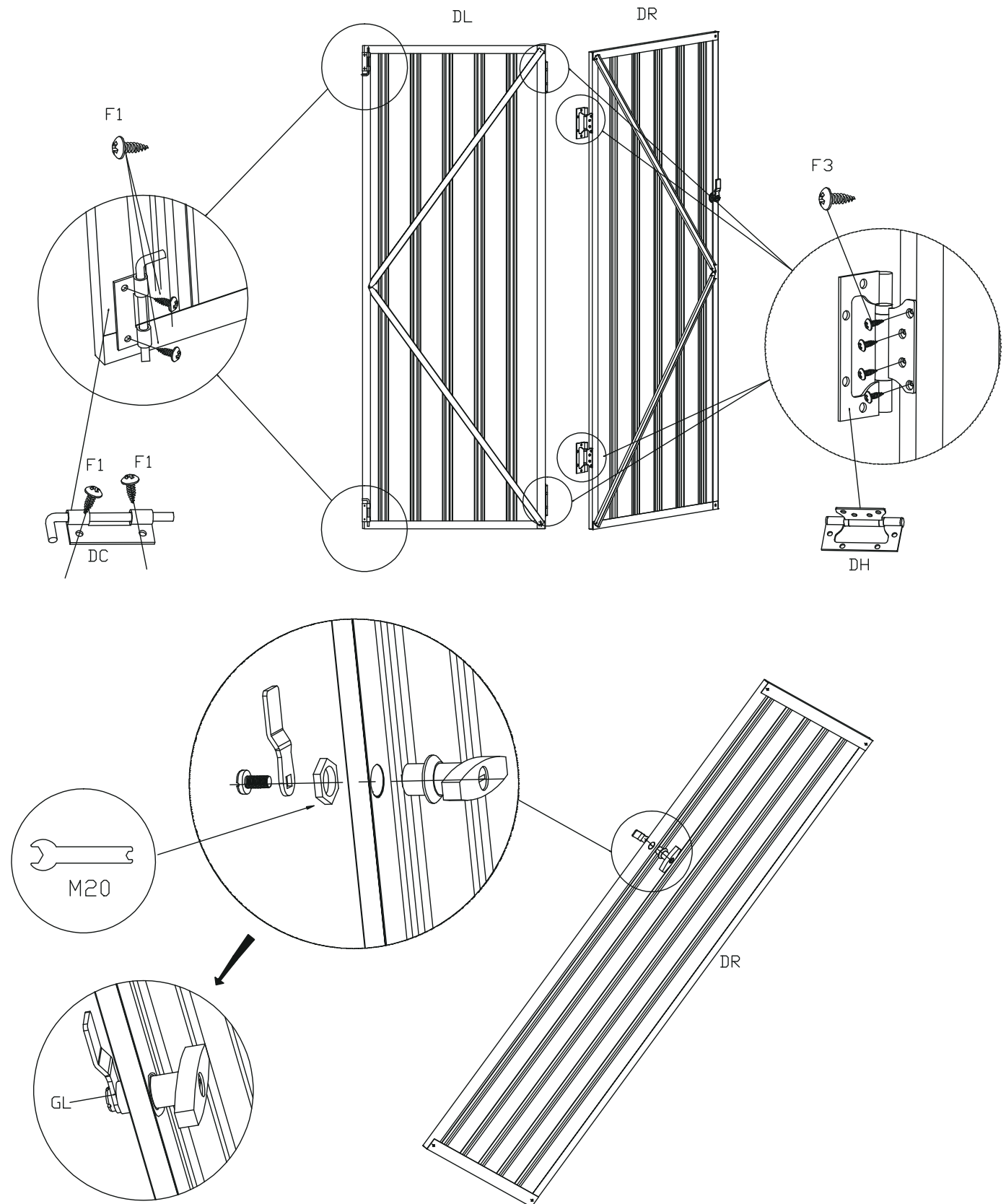

PART	NO.	QTY.
	DH	4
	DC	2
	F3	16
	GL	1
	F1	4



PART	NO.	QTY.
	DL	1
	DR	1
	F3	16

