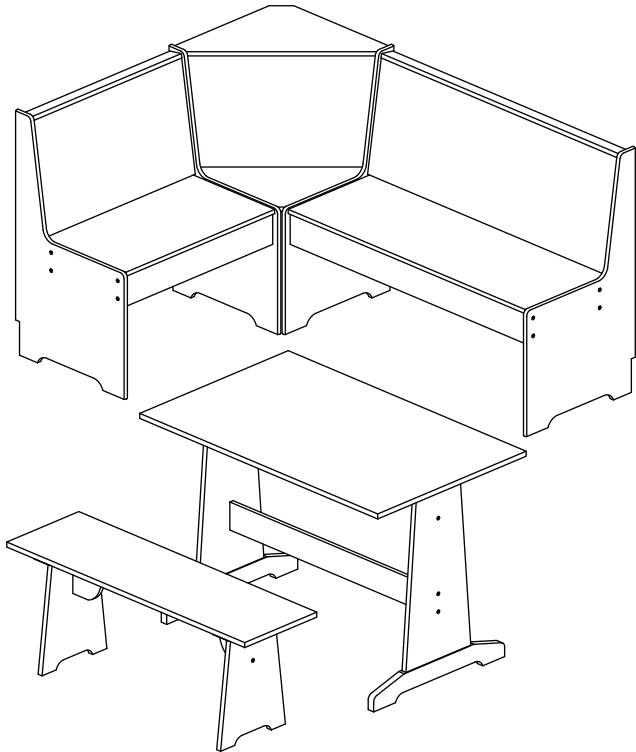

Table & Bench

Assembly Instructions - Please keep for future reference



RIGHT SIDE INSTALLATION

OR

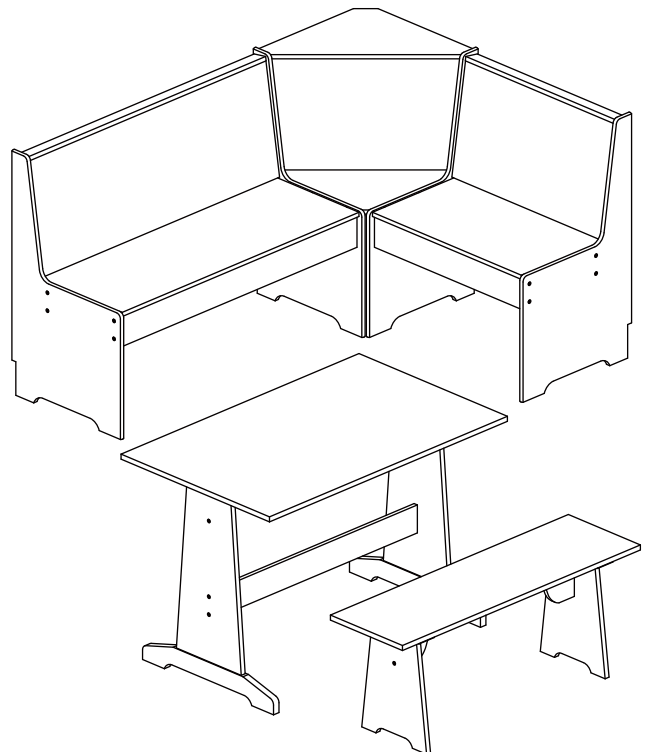

LEFT SIDE INSTALLATION

Dimensions

Width - 63.8 inch
Depth - 48 inch
Height - 34.2 inch

Contact Us

Please include the following information for faster assistance:

- Order number
- Purchase platform
- Purchase date
- Detailed description of the issue along with photos

Important – Please read these instructions fully before starting assembly



Safety and Care Advice

Important – Please read these instructions fully before starting assembly

- Check you have all the components and tools listed on the following pages.
- Remove all fittings from the plastic bags and separate them into their groups.
- Keep children and animals away from the work area, small parts could choke if swallowed.
- Make sure you have enough space to layout the parts before starting.

- During assembly do not stand or put weight on the product, this could cause damage.
- Assemble the item as close to its final position (in the same room) as possible.
- Assemble on a soft level surface to avoid damaging the unit or your floor.
- Parts of the assembly will be easier with 2 people.



- To reduce the likelihood of damaging your product please ensure that your power drill is set on a low torque setting.

Care and maintenance

- Only clean using a damp cloth and mild detergent, do not use bleach or abrasive cleaners.
- From time to time check that there are no loose screws on this unit.
- This product should not be discarded with household waste. Take to your local authority waste disposal centre.

Handy Hints

- Assemble all parts and bolts loosely during assembly, only once the product is complete should you fully tighten the bolts
- Regularly check and ensure that all bolts and fittings are tightened properly.

WARNING In order to help prevent overturning – please follow these instructions

To help prevent product toppling over please follow the below steps:-

Use the anti tip strap or wall fixing method provided (if applicable)
Do not allow children to climb or hang on the furniture
Do not open more than one drawer at a time
Do not place heavy items in the top drawers
Do not place heavy items on top of the furniture, unless the furniture has been designed for this purpose

please note that only the anti tip strap is provided.

You will need to provide wall plugs and screws applicable for your wall type

CUSTOMER SERVICE GUIDE

Thank you for choosing our product! We are committed to providing you with excellent service. If you find any missing parts, damaged packaging, or product damage after receiving all packages, please follow the steps below to quickly contact our customer service team. We will do our best to resolve your issue.

1. Missing Parts

Verify Parts:

1. Refer to the “Parts List” in the manual to verify the name, specifications, and quantity of the missing parts.
2. Take a clear photo of the parts list and mark the missing parts with detailed information, e.g., “Missing 5 pieces of M6x30mm screws.”

Contact Us:

- By Email:

Send an email with the subject line “Missing Parts Issue.” Include the following in the email:

- A description of the missing parts and a photo of the parts list.
- Order details (order number, purchase platform, purchase date).

2. Product or Packaging Damage

If it affects normal use:

Steps:

1. Take clear photos or videos showing the damaged parts and the extent of the damage (multi-angle shots are recommended).
2. Email the photos/videos along with other details with the subject line “Product Damage Issue.”

Resolution:

After verification, we will arrange for a replacement part, product exchange, or refund as quickly as possible.

If it does not affect normal use:

Steps:

1. Contact our customer service team
2. Provide a description of the damage and include relevant photos or videos.

Resolution:

We will provide repair guidance or an appropriate compensation plan based on the specific situation.

Helpful Tips

To process your issue efficiently, please prepare the following information:

- Order details (order number, purchase platform, purchase date).
- Clear photos or videos.
- We are committed to providing quick and professional solutions, no matter the size of the issue, to ensure your satisfaction.

Thank you for your trust and support! We hope you enjoy using our product!

Componets - Panels

Please check you have all the panels listed below

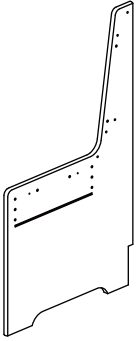

1 (870*500*15mm x1)

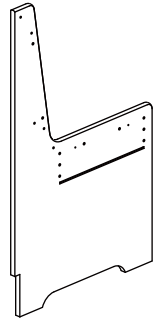

2 (870*500*15mm x1)

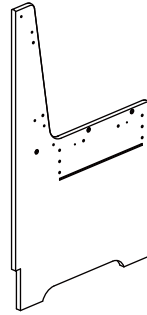

3 (870*500*15mm x1)

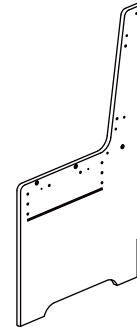

4 (870*500*15mm x1)

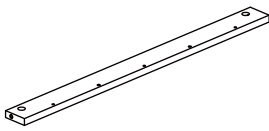

5 (688*53*15mm x1)

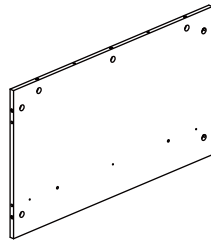

6 (688*400*12mm x1)

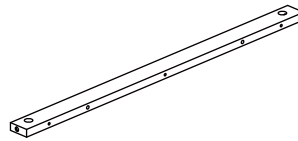

7 (688*40*15mm x1)

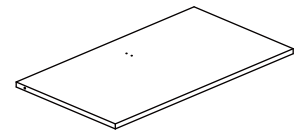

8 (682*380*15mm x1)

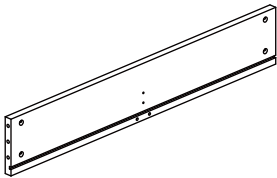

9 (688*115*15mm x2)

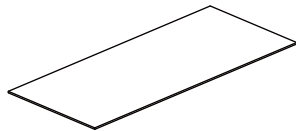

10 (696*298*4mm x1)

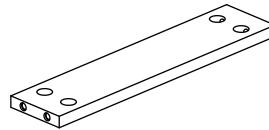

11 (290*60*12mm x3)

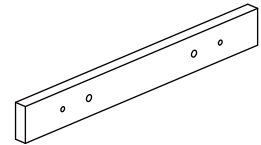

12 (283*35*12mm x4)

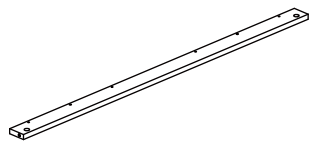

13 (1091*53*15mm x1)

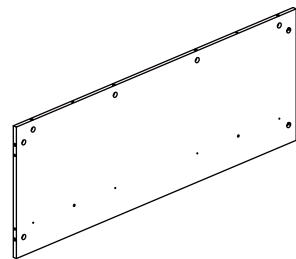

14 (1091*400*12mm x1)

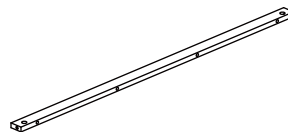

15 (1091*40*15mm x1)

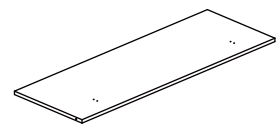

16 (1085*380*15mm x1)

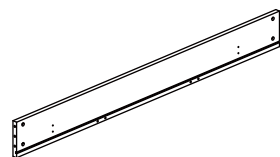

17 (1091*115*15mm x2)

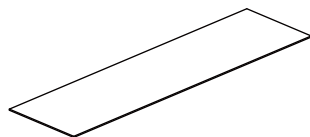

18 (1099*298*4mm x1)

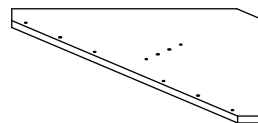

19 (500*500*15mm x1)

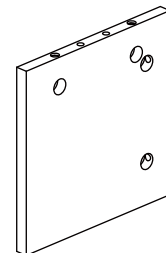

20 (180*180*12mm x1)

Componets - Panels

Please check you have all the panels listed below

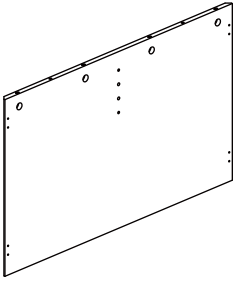

21 (660*400*12mm x1)

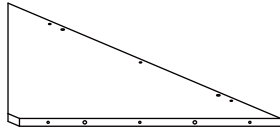

22 (476*476*15mm x1)

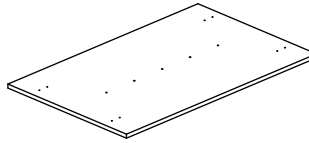

23 (1090*680*18mm x1)

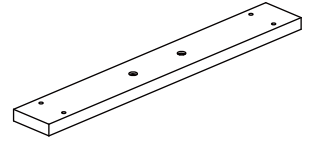

24 (500*70*18mm x2)

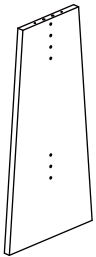

25 (614*297*18mm x2)

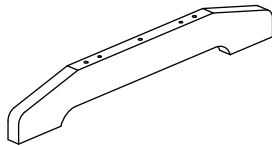

26 (600*90*25mm x2)

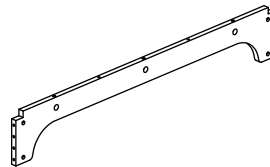

27 (930*145*15mm x1)

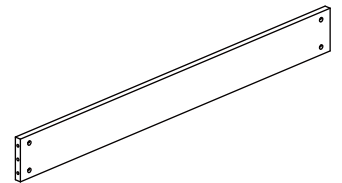

28 (930*95*15mm x1)

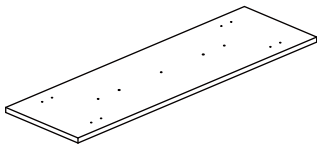

29 (1090*330*18mm x1)

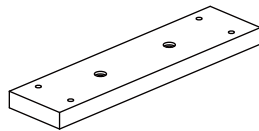

30 (280*70*18mm x2)

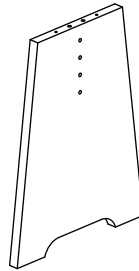

31 (400*297*18mm x2)

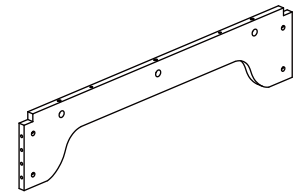









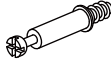



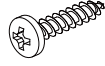



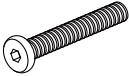

32 (800*170*15mm x1)

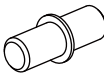
Componets - Fittings

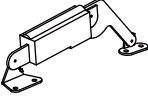
Please check you have all the panels listed below

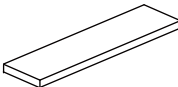
Note: The quantities below are the correct amount to complete the assembly. In some cases more fittings may be supplied are required.

A  6*30mm Wooden Dowel x 62	B  6*35mm Cam Bolt x 49	C  Cam Lock x 49
D  6*20mm Wooden Dowel x 8	E  4*14mm Screw x 12	F  4*20mm Screw x 8
G  4*40mm Screw x 10	H  3.5*12mm Screw x 16	I  x 26
J  5*30mm Screw x 16	K  5*40mm Screw x 14	L  5*60mm Screw x 6
M  6*50mm Bolt x 28	N  x 28	O  x 4
P  x 4	Q  x 3	R  x 1
S  x 12	T  x 4	

Tools required

 Phillips screwdriver
(medium & large)

Ruler - Use this ruler to help correctly identify the screws

mm

0 5 10 15 20 25 30 35 40 45 50 55 60 65 70 75 80 85 90 95 100 105 110 115 120 125 130 135 140 145 150 155 160 165 170



The screws length is measured from the head to the point (30mm screw shown).

0 1 2 3

inch

Using Camlocks

Step 1

Connect the male camlock as directed in the assembly instructions using a screwdriver.

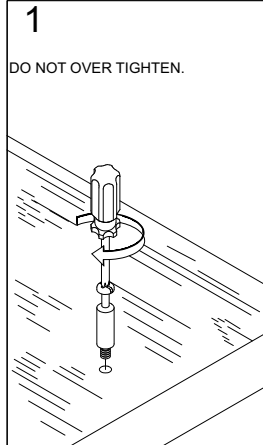

Step 2

Push the male camlock into the entry hole.

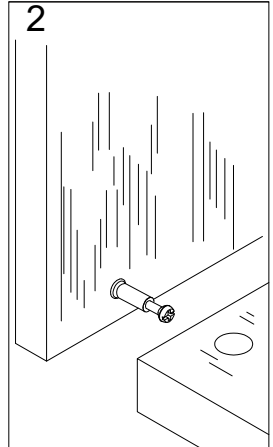

Step 3

Insert the female camlock as shown in the instruction.

Note: ensure that the arrow on the top of the camlock points towards the entry hole for the male camlock.

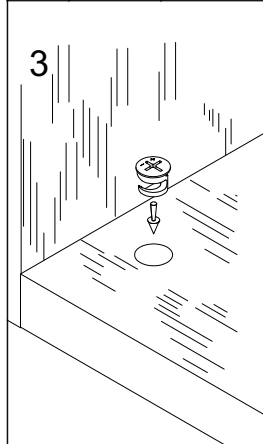

Step 4

Turn the female camlock clockwise with a screwdriver.

You should feel a click when the camlock is locked in place.

The joint is now secure.

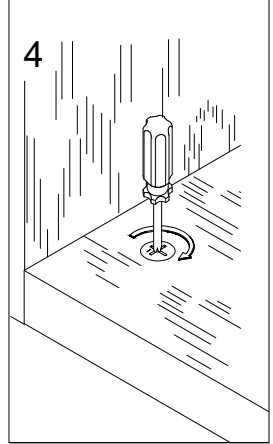

Assembly Instructions

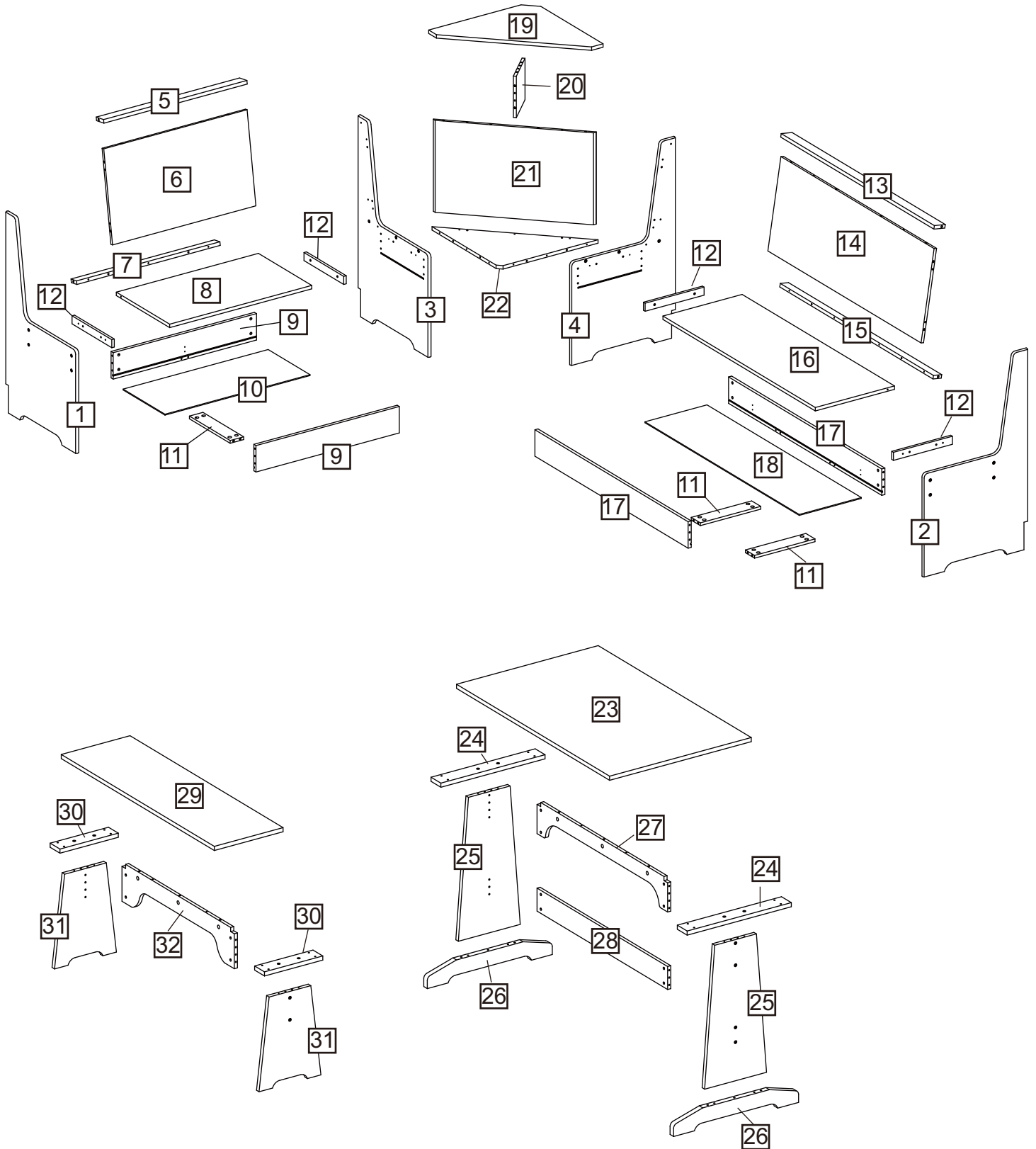

Assembly Instructions



There are two combination methods for Park A & Park B. The first one is shown on Page 9 as Park A (Option 1) & Park B (Option 1); the second one is shown on Page 10 as Park A (Option 2) & Park B (Option 2).

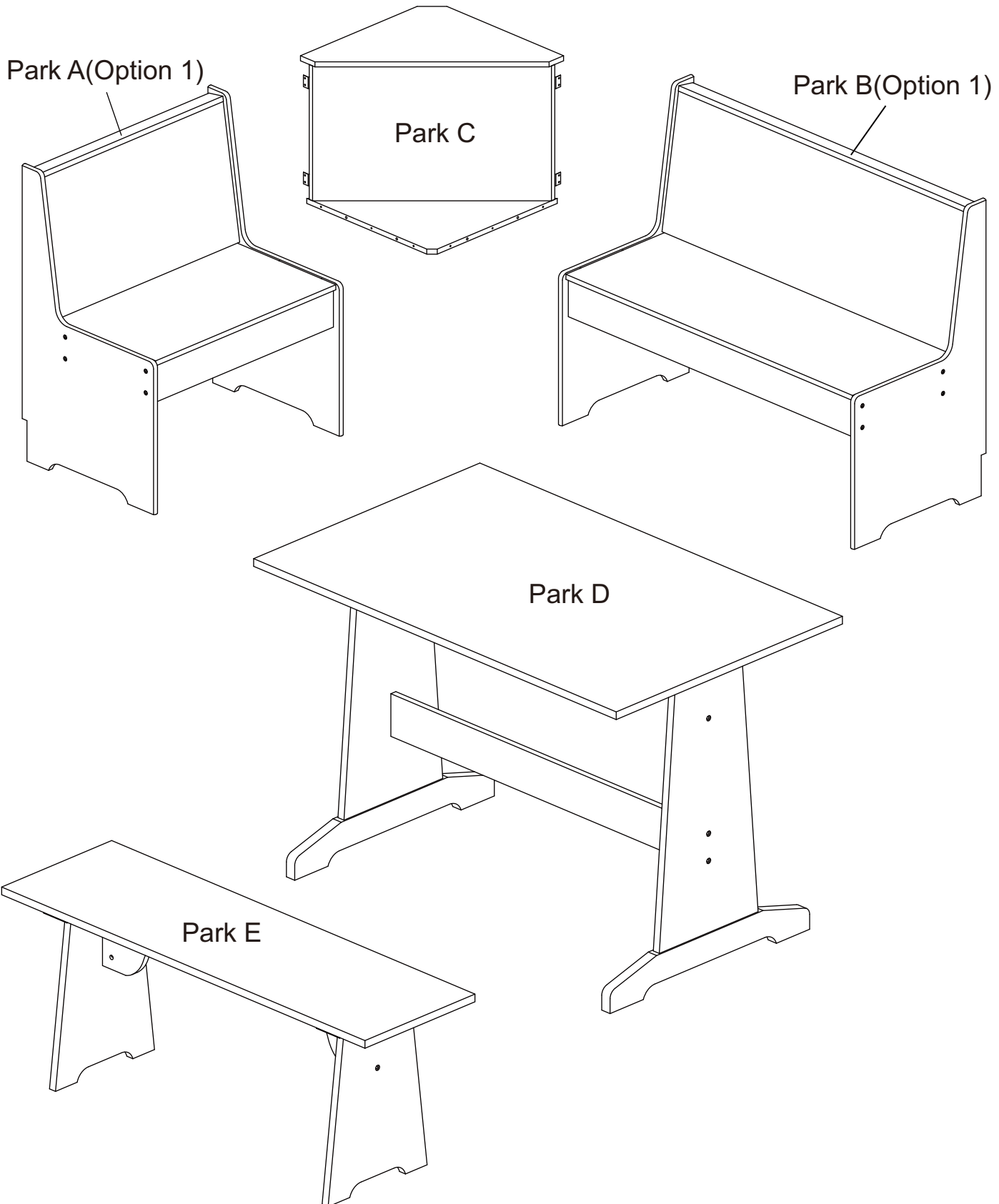

Assembly Instructions



There are two combination methods for Park A & Park B. The first one is shown on Page 9 as Park A (Option 1) & Park B (Option 1); the second one is shown on Page 10 as Park A (Option 2) & Park B (Option 2).

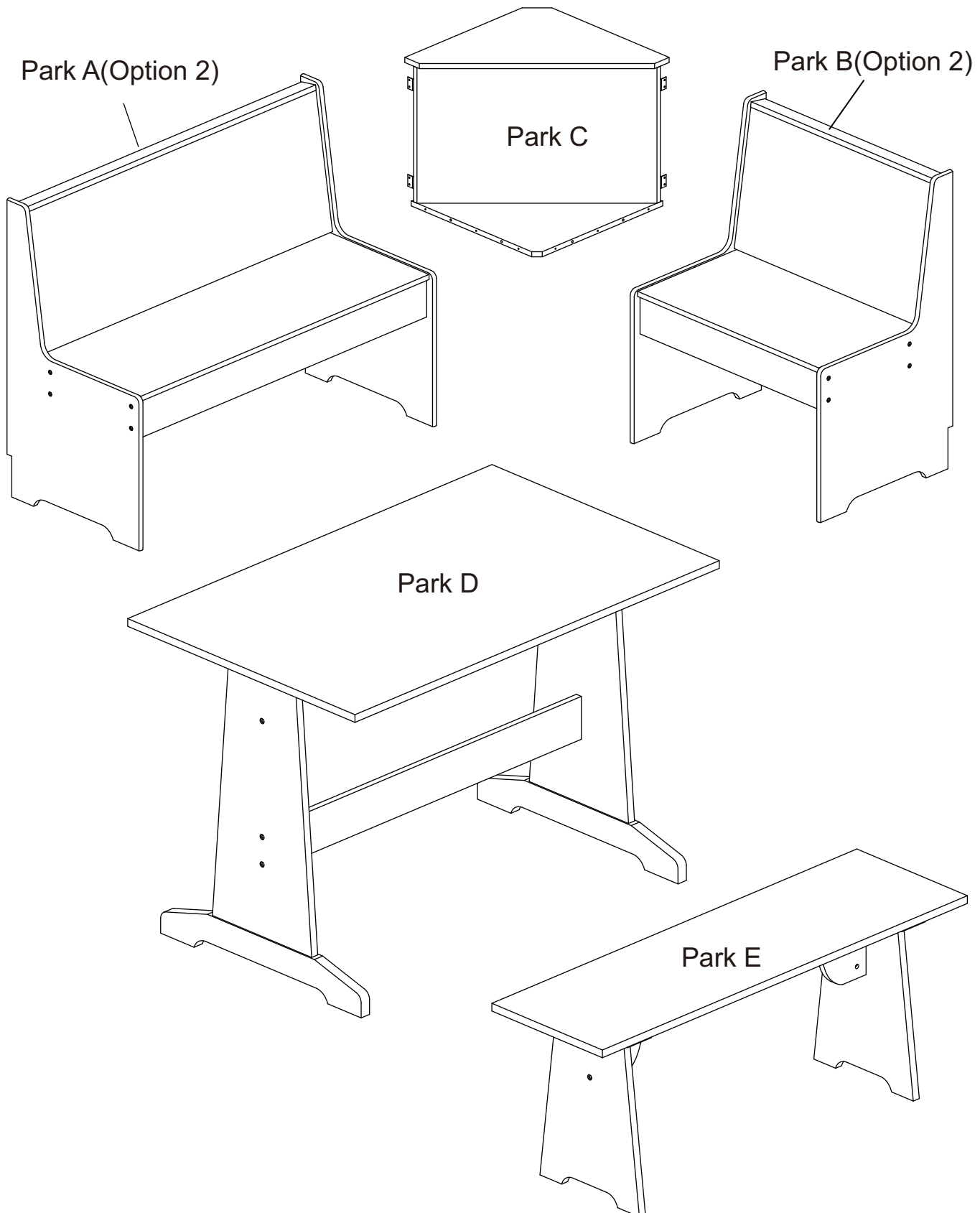

Assembly Instructions



The short chair has two combination methods: Park A (Option 1) and Park B (Option 2). Pages 11-16 show the assembly steps for Park A (Option 1). If you want to assemble Park B (Option 2), you only need to replace Board NO.1& 3 with Board NO. 4 & 2.

Park A(Option 1)

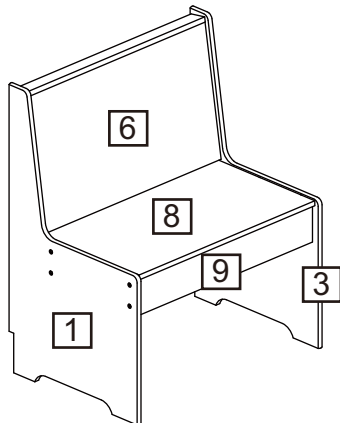

Park B(Option 2)

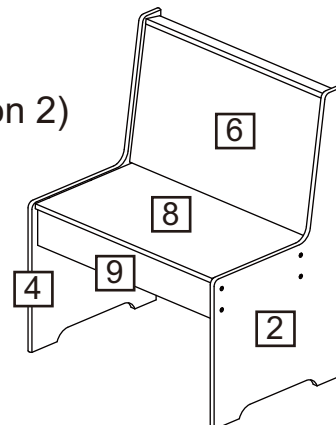

Step 1

CAM-LOCK

Tighten until shoulder is flush with panel. Do not overtighten or undertighten (see example below)

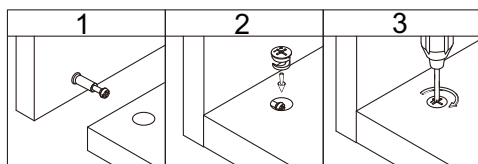
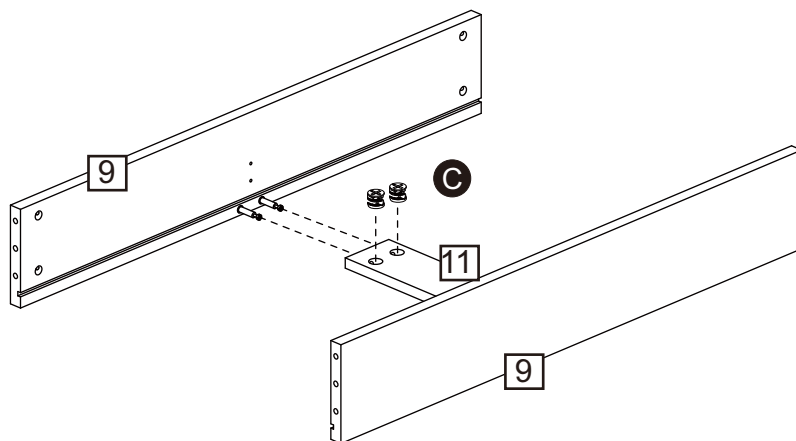
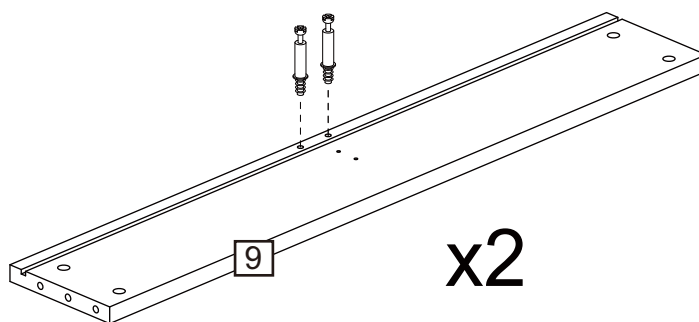
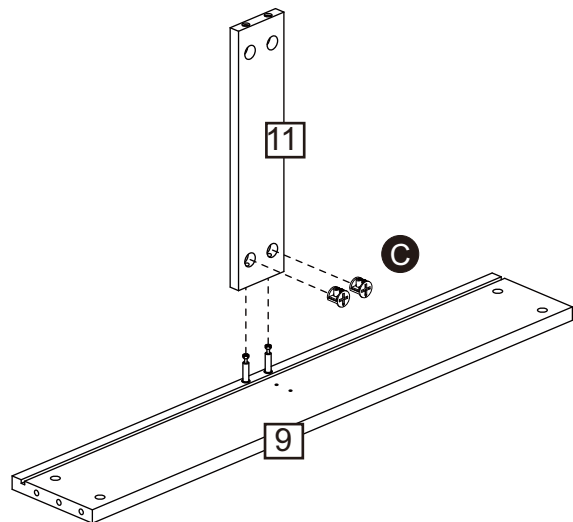
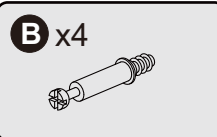
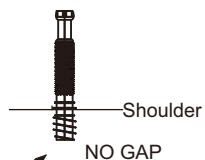
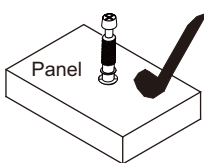
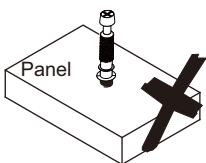

Assembly Instructions

Step 2

CAM-LOCK

Tighten until shoulder is flush with panel. Do not overtighten or undertighten (see example below)

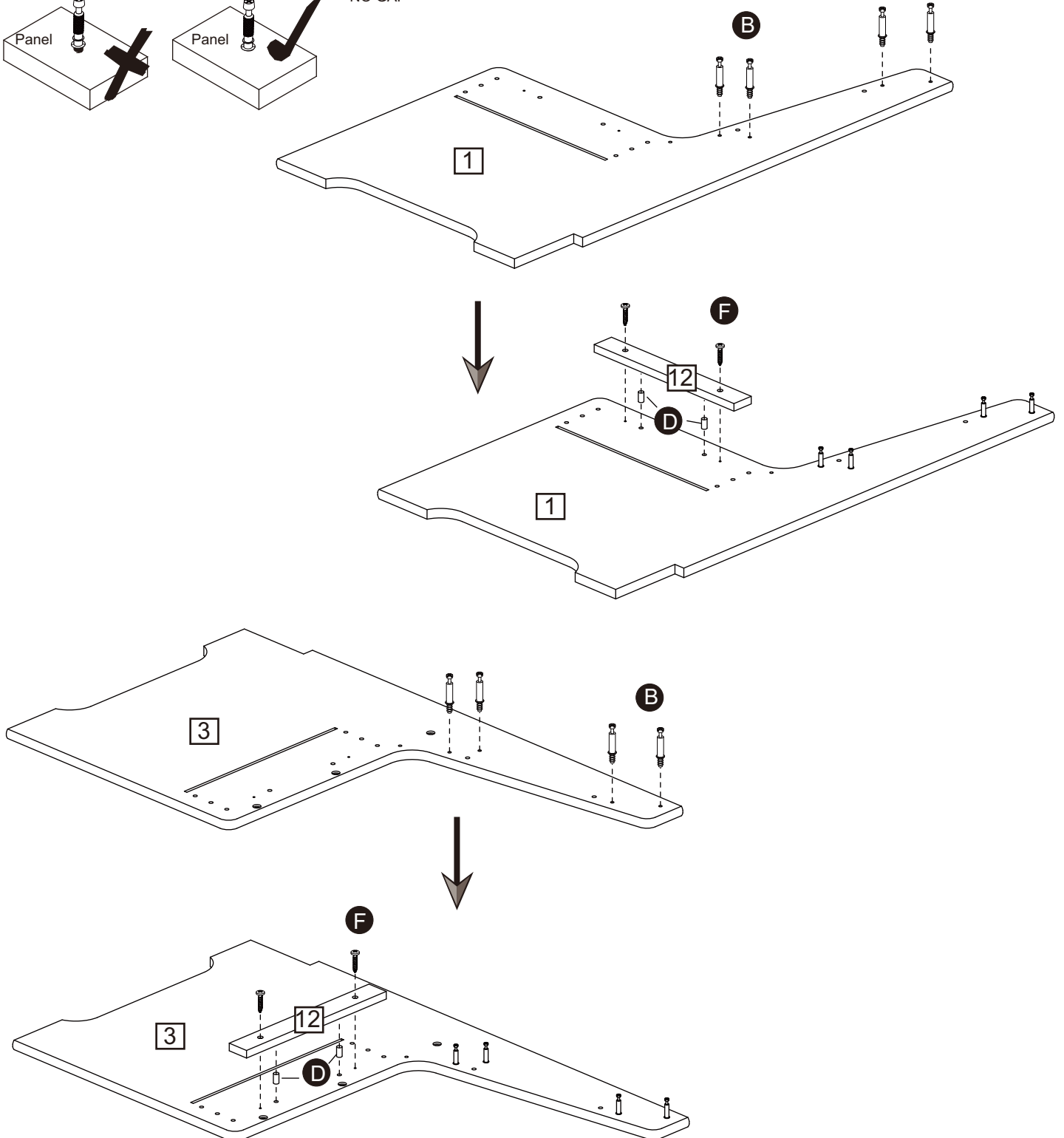
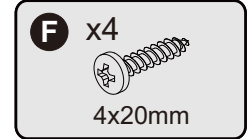
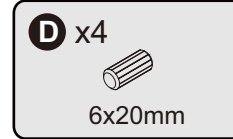
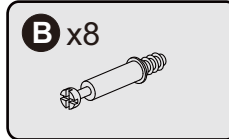
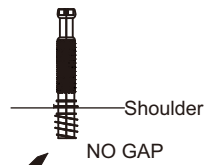
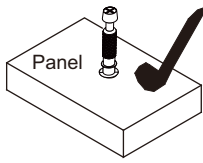
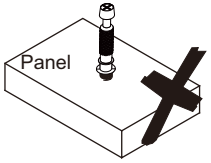

Assembly Instructions

Step 3

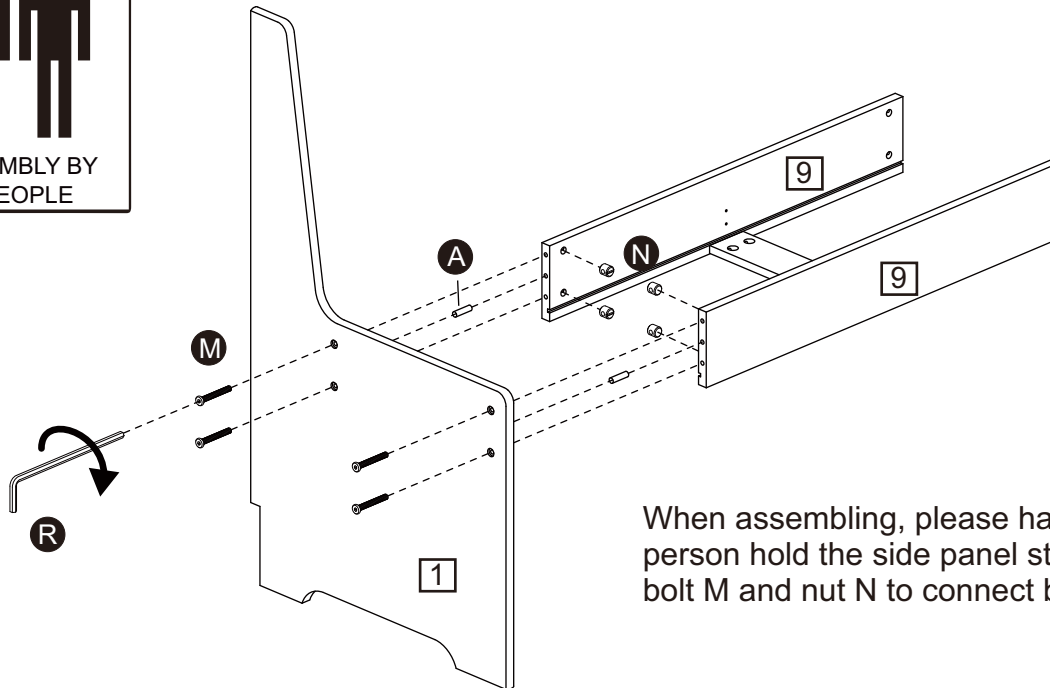
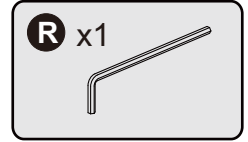
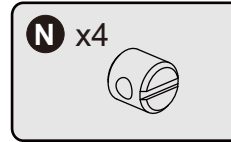
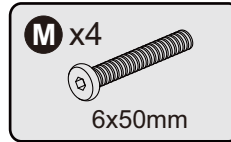
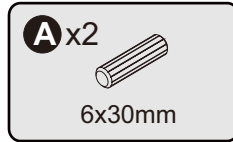
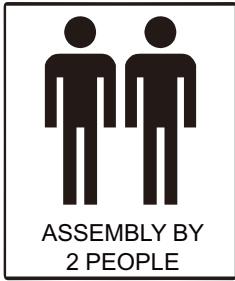

When assembling, please have another person hold the side panel steady, and use bolt M and nut N to connect board No.1 & 9.

Step 4

CAM-LOCK

Tighten until shoulder is flush with panel. Do not overtighten or undertighten (see example below)

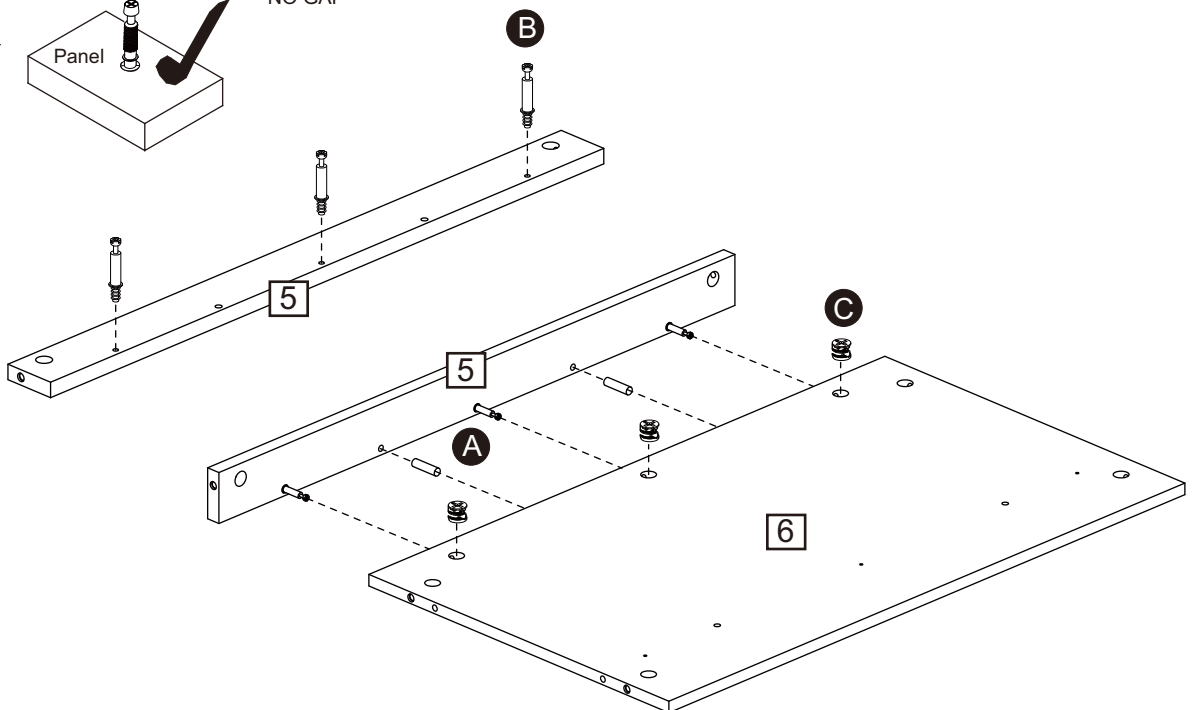
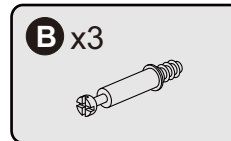
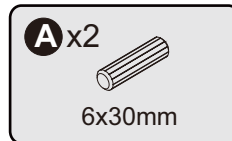
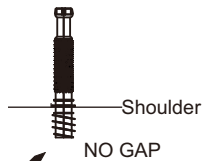
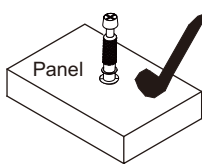
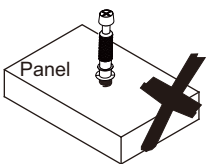

Assembly Instructions

Step 5

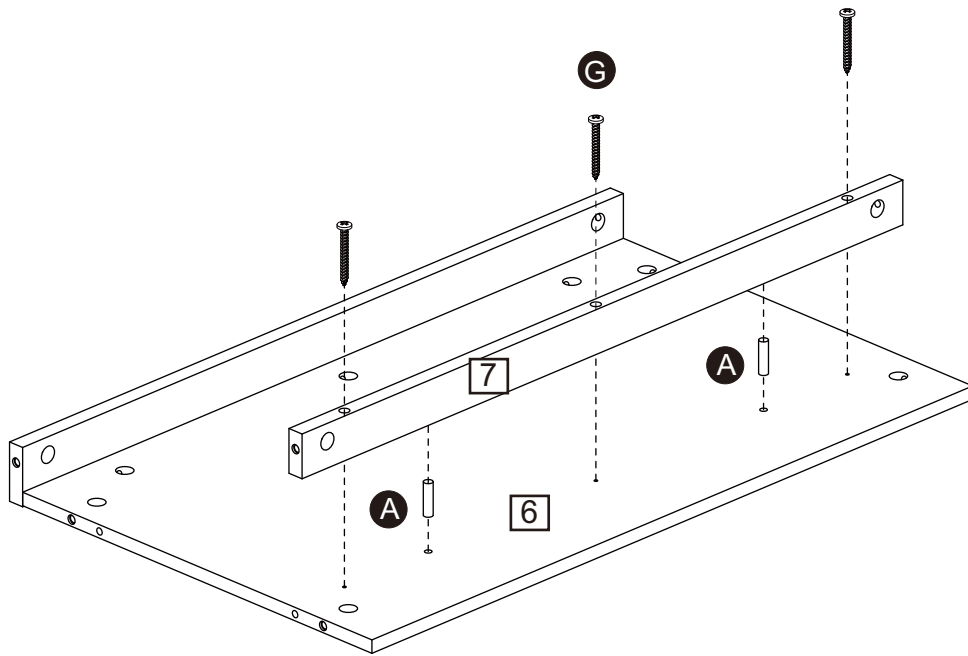

A x2
6x30mm

G x3
4x40mm

Step 6

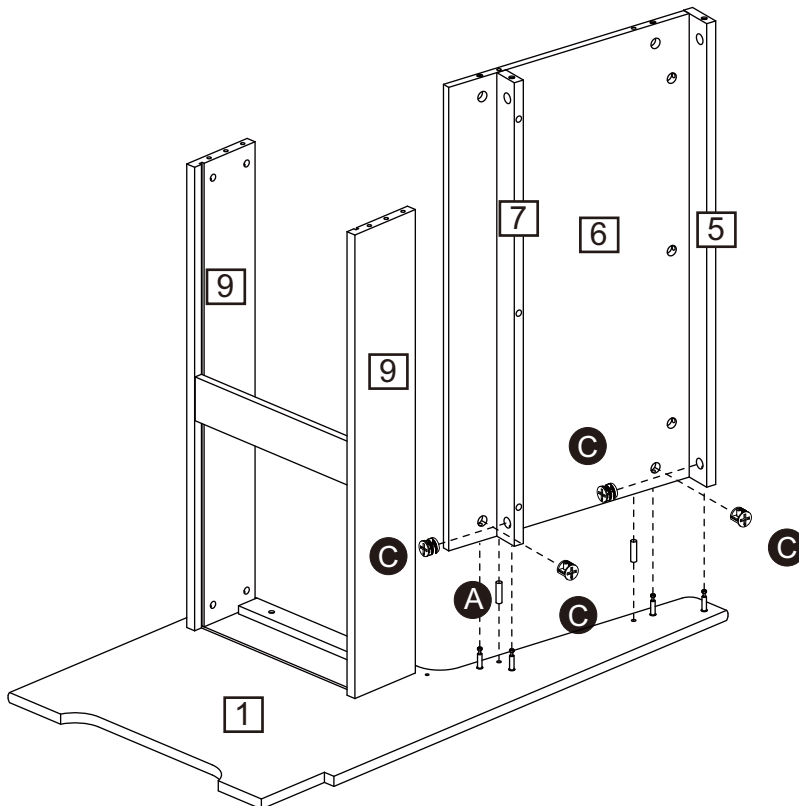

A x2
6x30mm

C x4

Assembly Instructions

Step 7

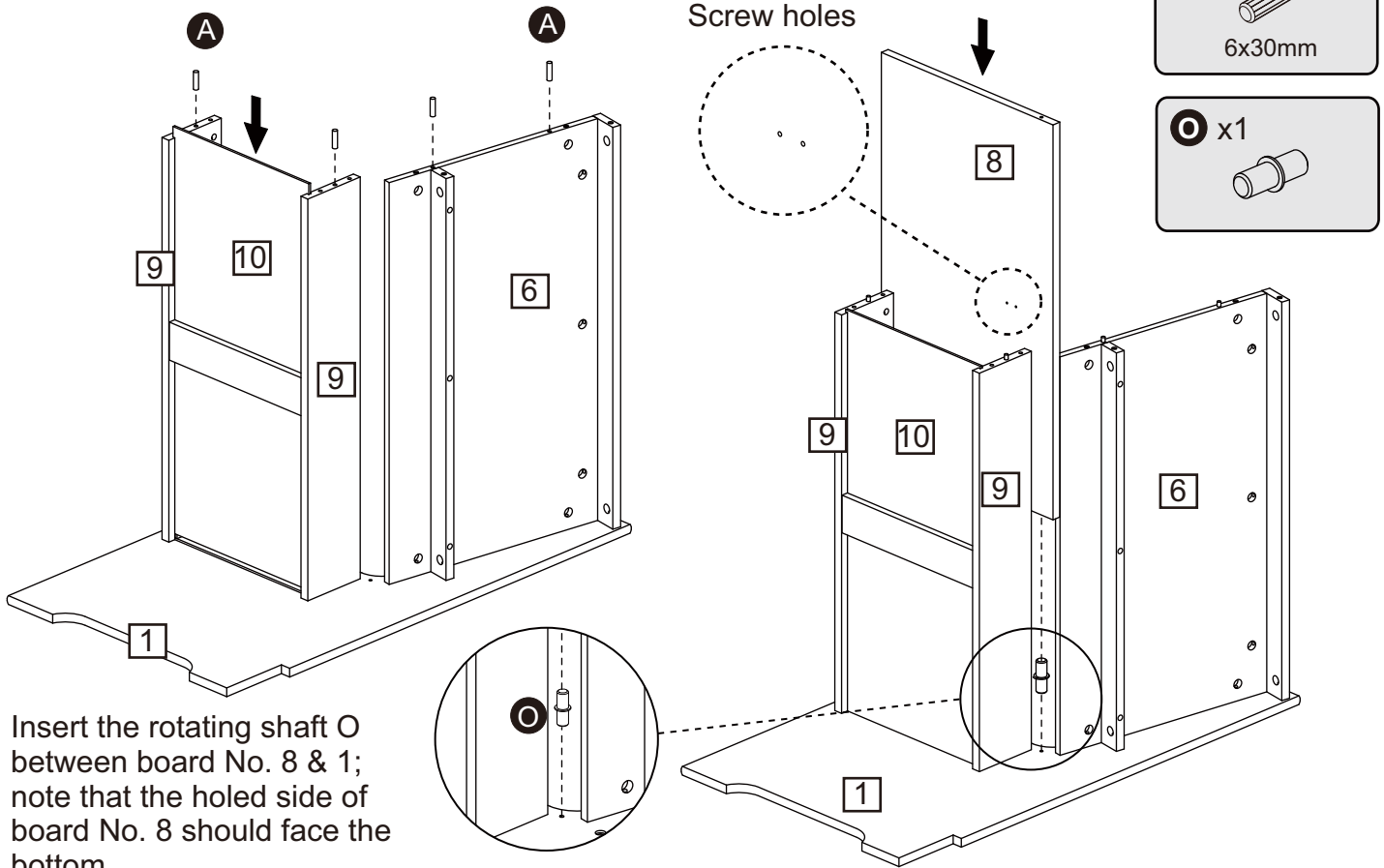

Step 8

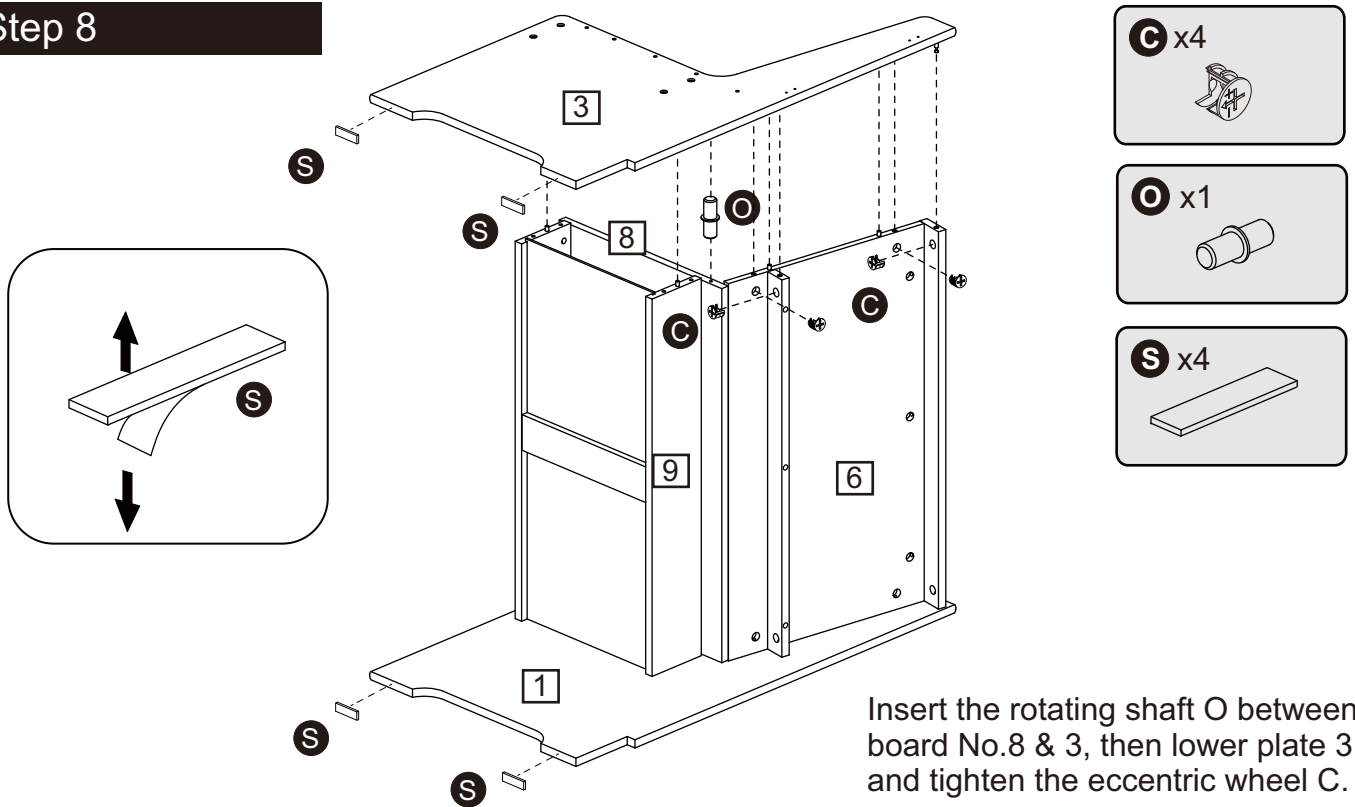

Assembly Instructions

Step 9

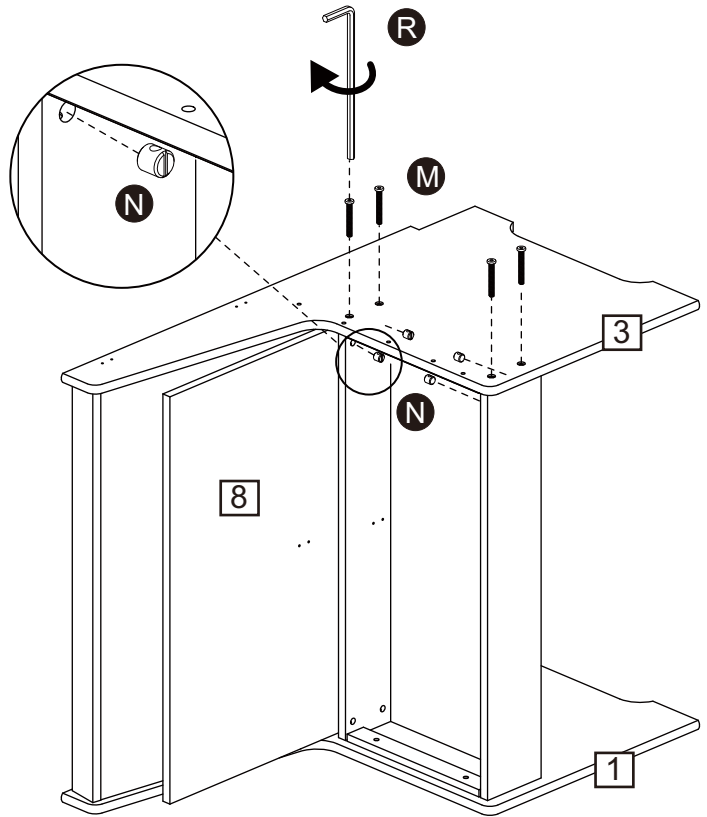
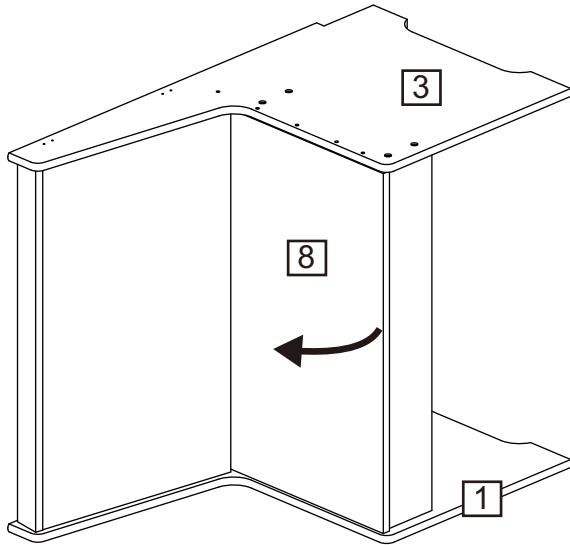
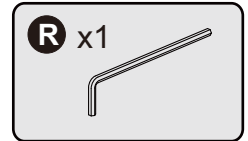
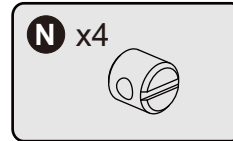
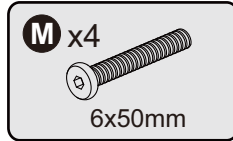

Please open the No. 8 cover plate.

Step 10

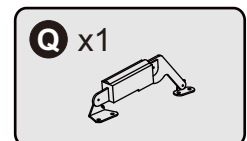
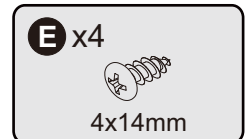
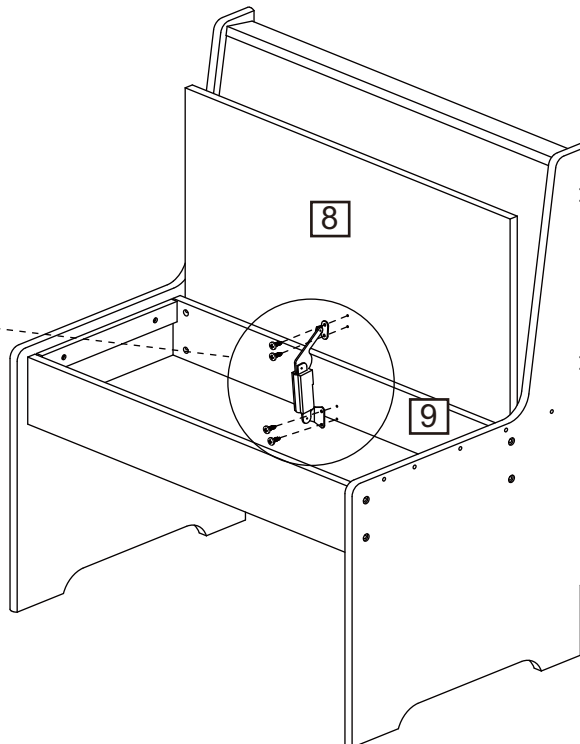
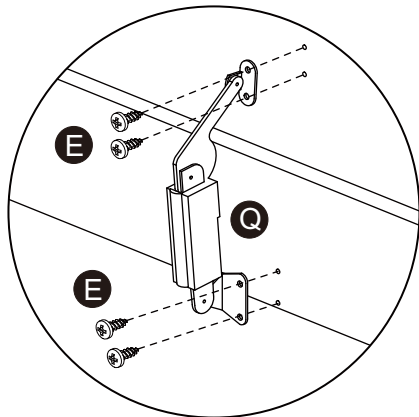

Assembly Instructions



The short chair has two combination methods: Park B (Option 1) and Park A (Option 2). Pages 17-23 show the assembly steps for Park B (Option 1). If you want to assemble Park A (Option 2), you only need to replace Board NO.4& 2 with Board NO. 1 & 3.

Park B(Option 1)

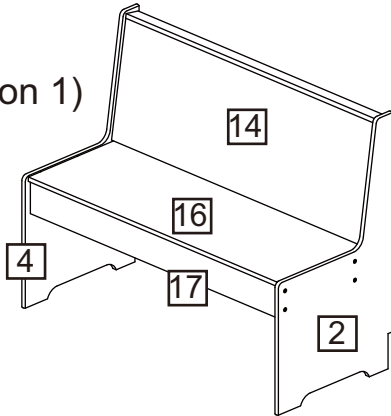

Park A(Option 2)

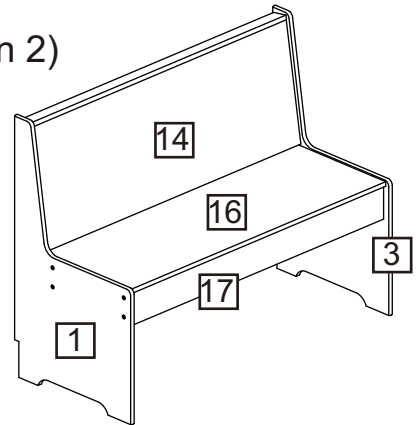

Step 11

CAM-LOCK

Tighten until shoulder is flush with panel. Do not overtighten or undertighten (see example below)

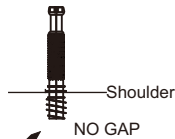
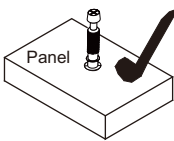
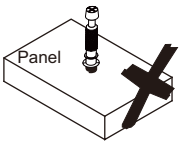

B



B x8

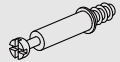

C x8



x2

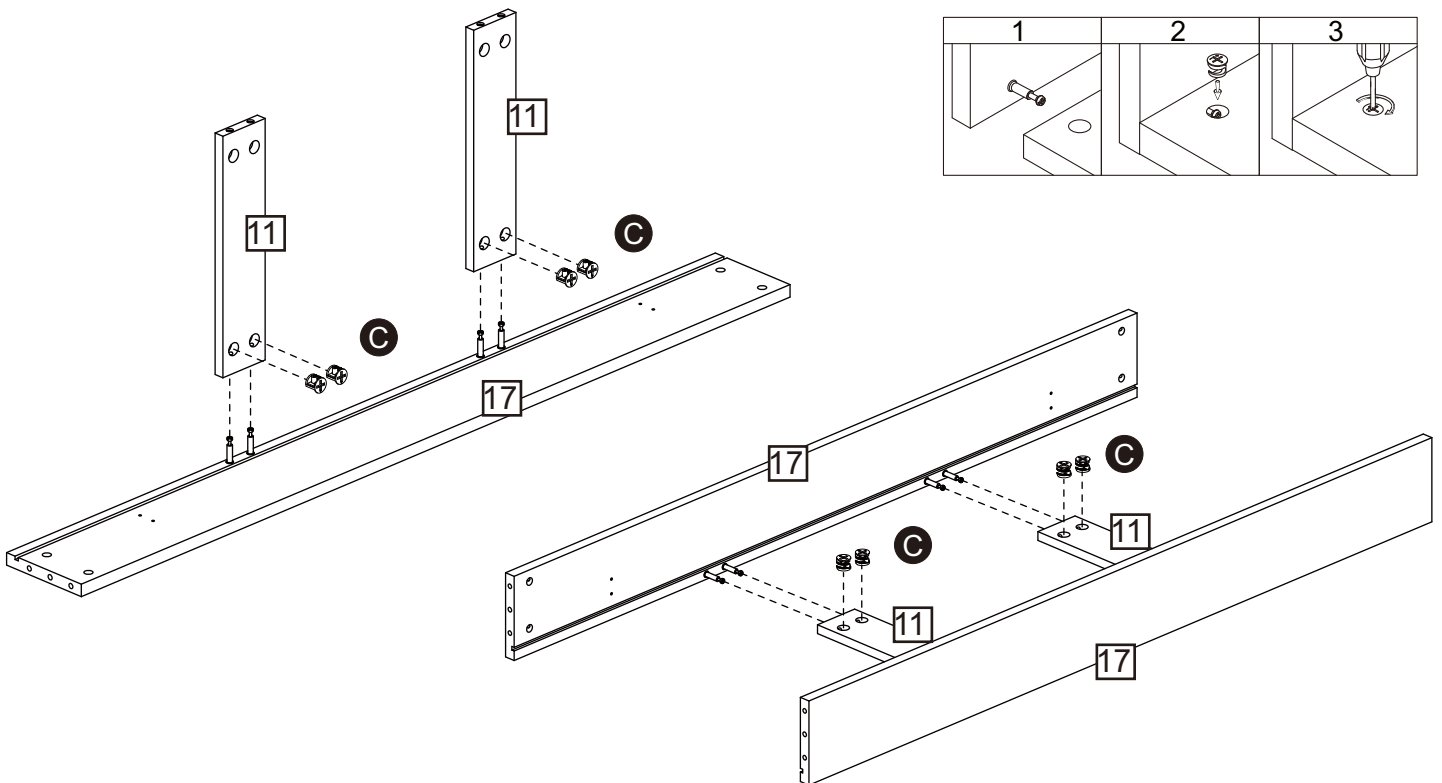

Assembly Instructions

Step 12

CAM-LOCK

Tighten until shoulder is flush with panel. Do not overtighten or undertighten (see example below)

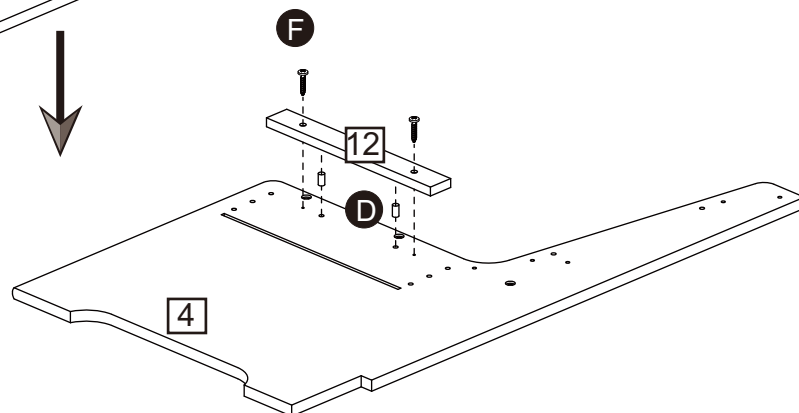
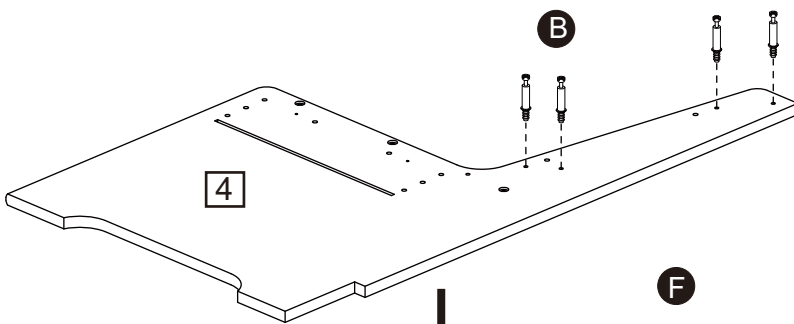
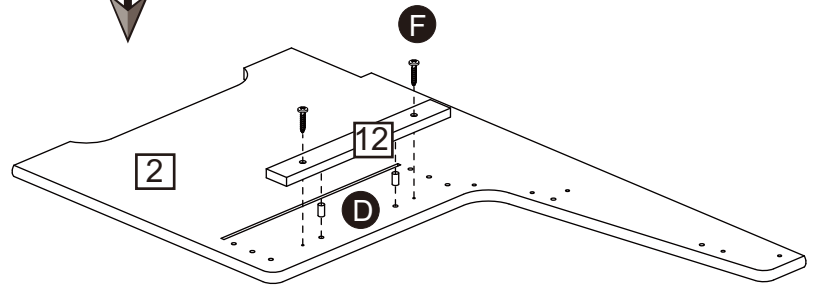
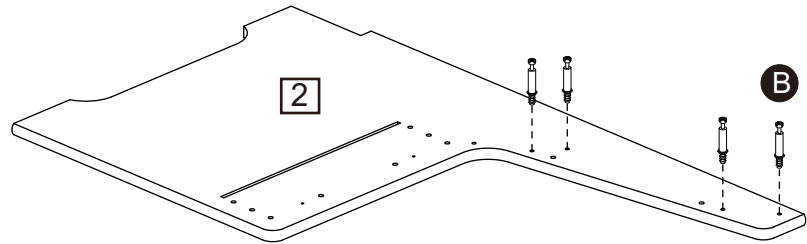
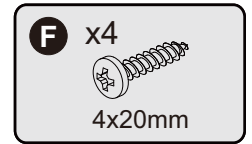
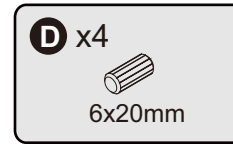
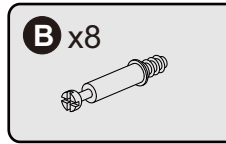
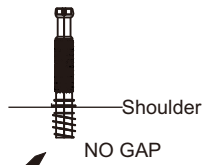
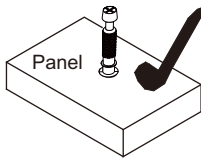
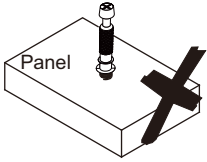

Assembly Instructions

Step 13

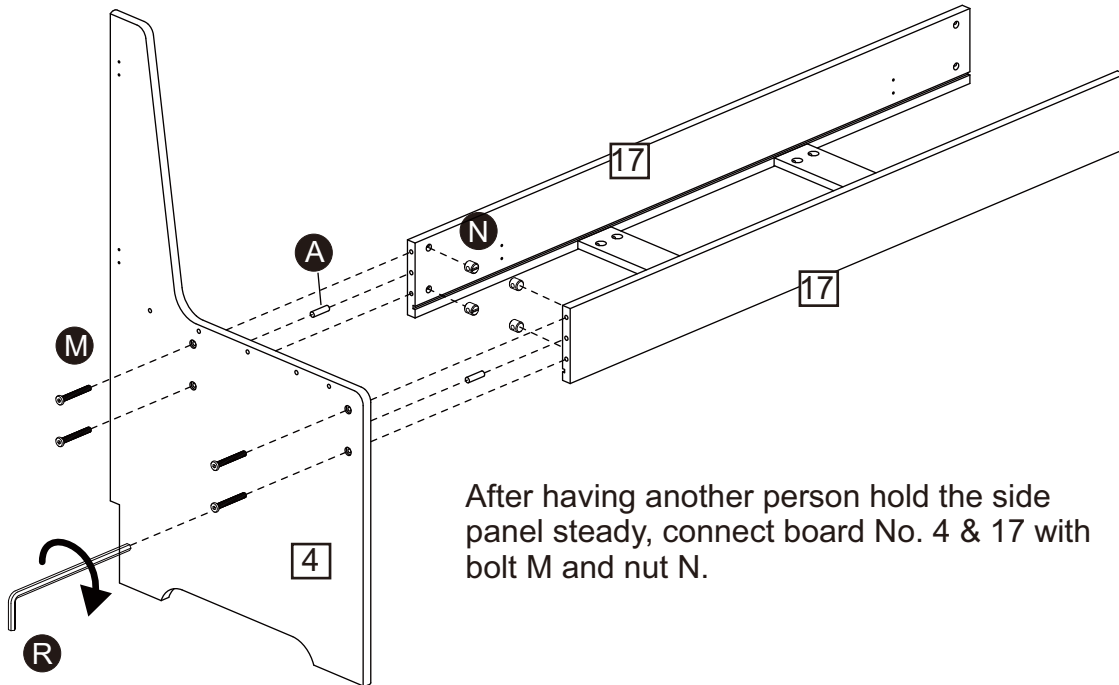
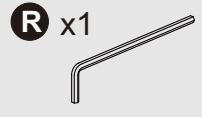
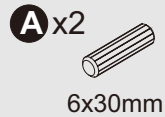

After having another person hold the side panel steady, connect board No. 4 & 17 with bolt M and nut N.

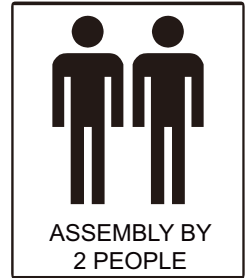

Step 14

CAM-LOCK

Tighten until shoulder is flush with panel. Do not overtighten or undertighten (see example below)

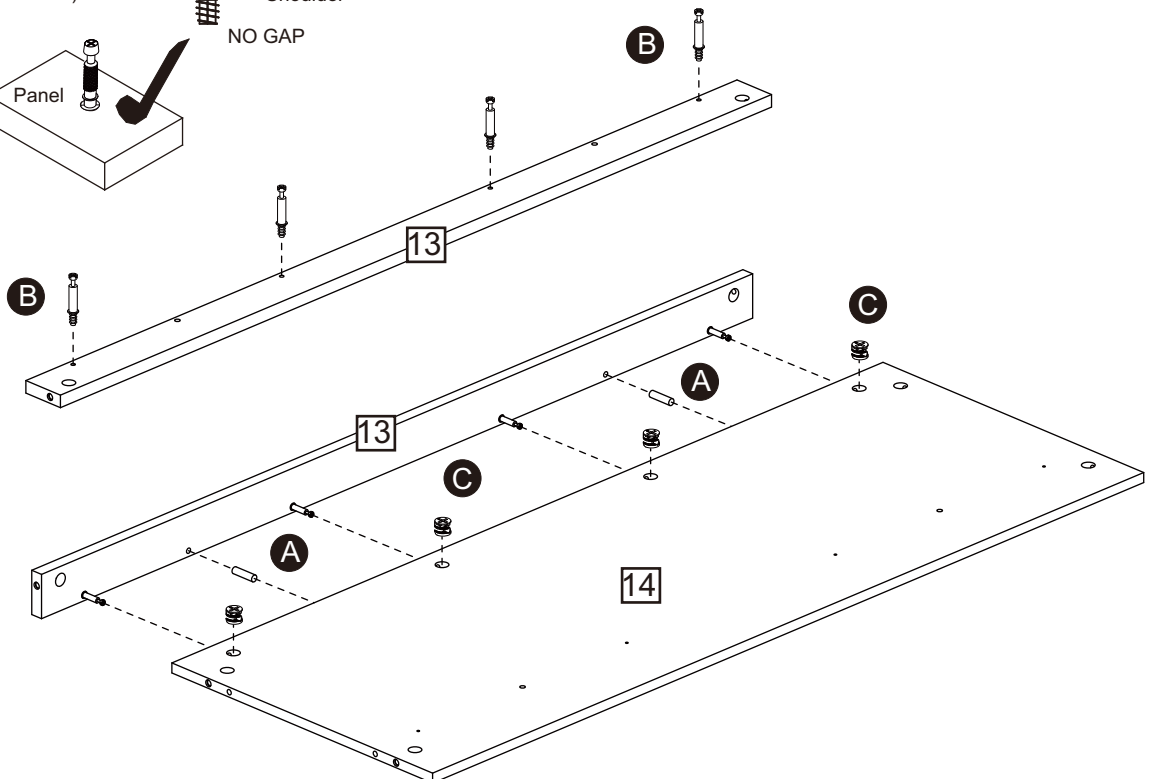
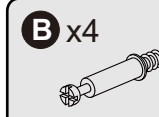
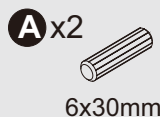
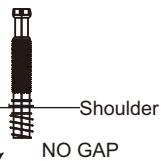
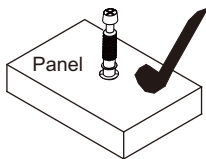
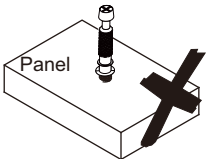

Assembly Instructions

Step 15

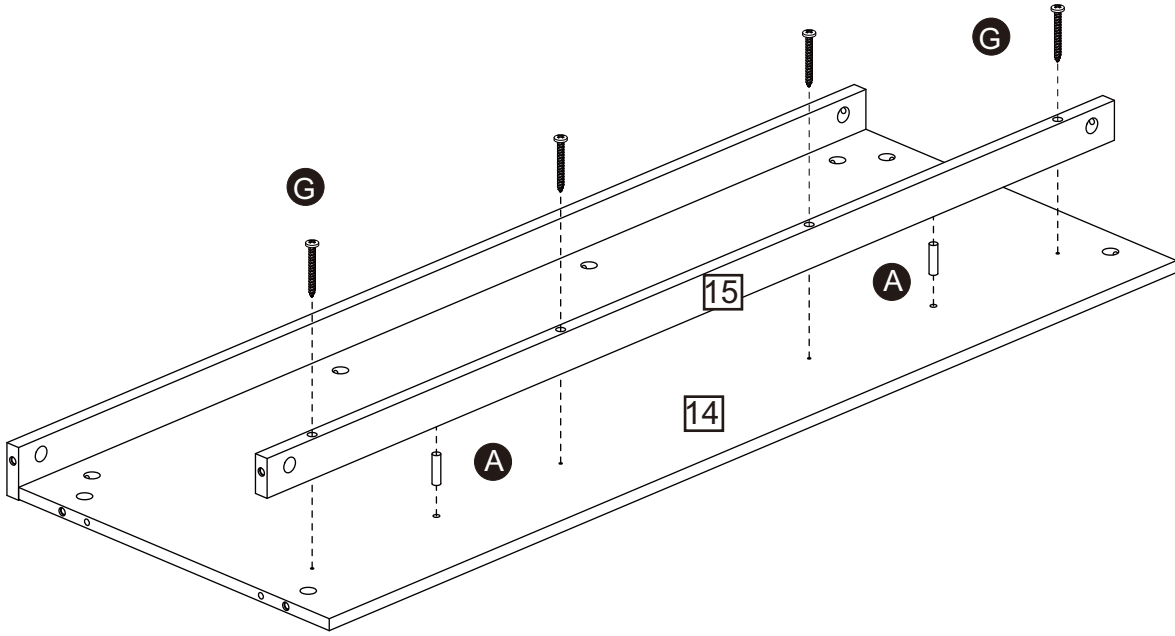
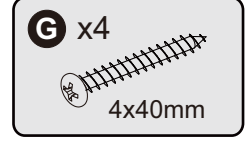

Step 16

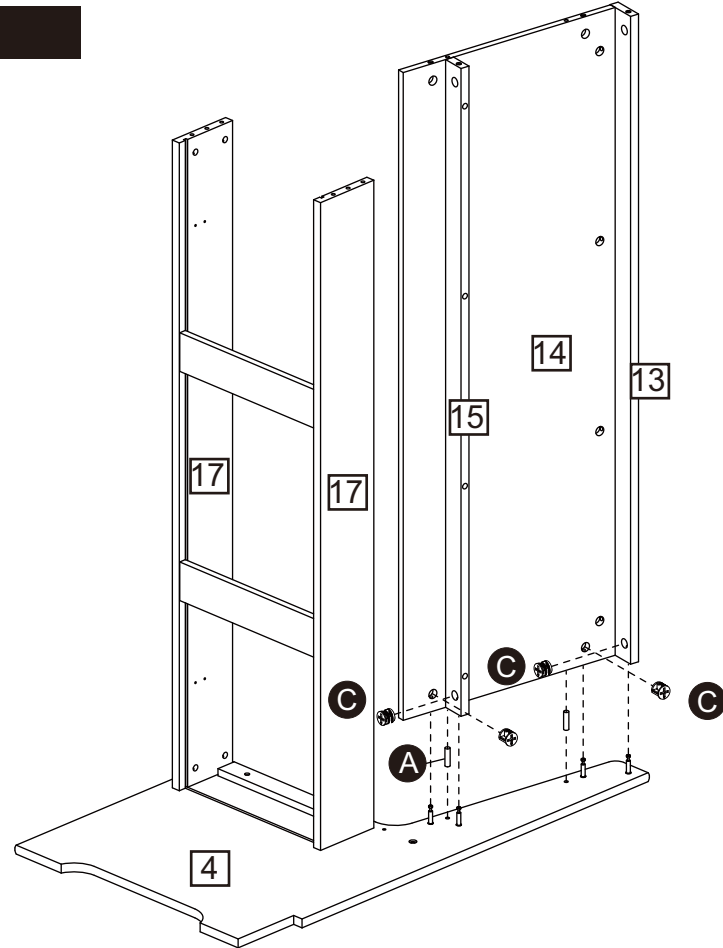

Assembly Instructions

Step 17

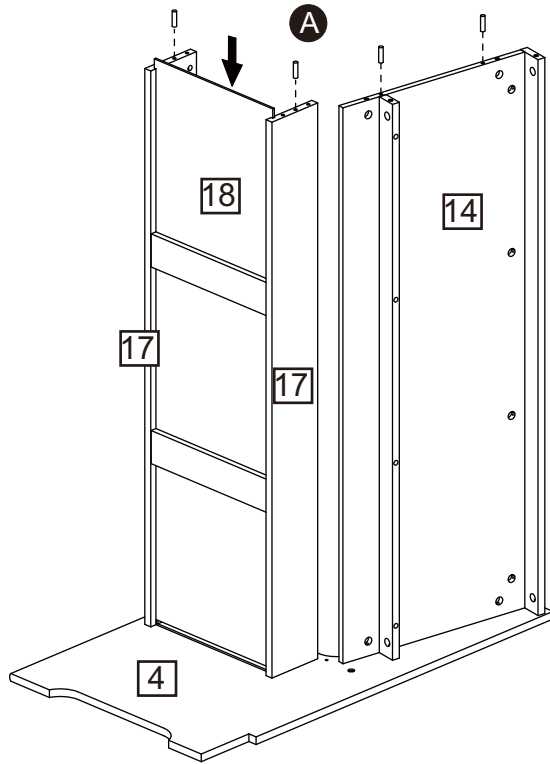

A x4
6x30mm

Step 18

Screw holes

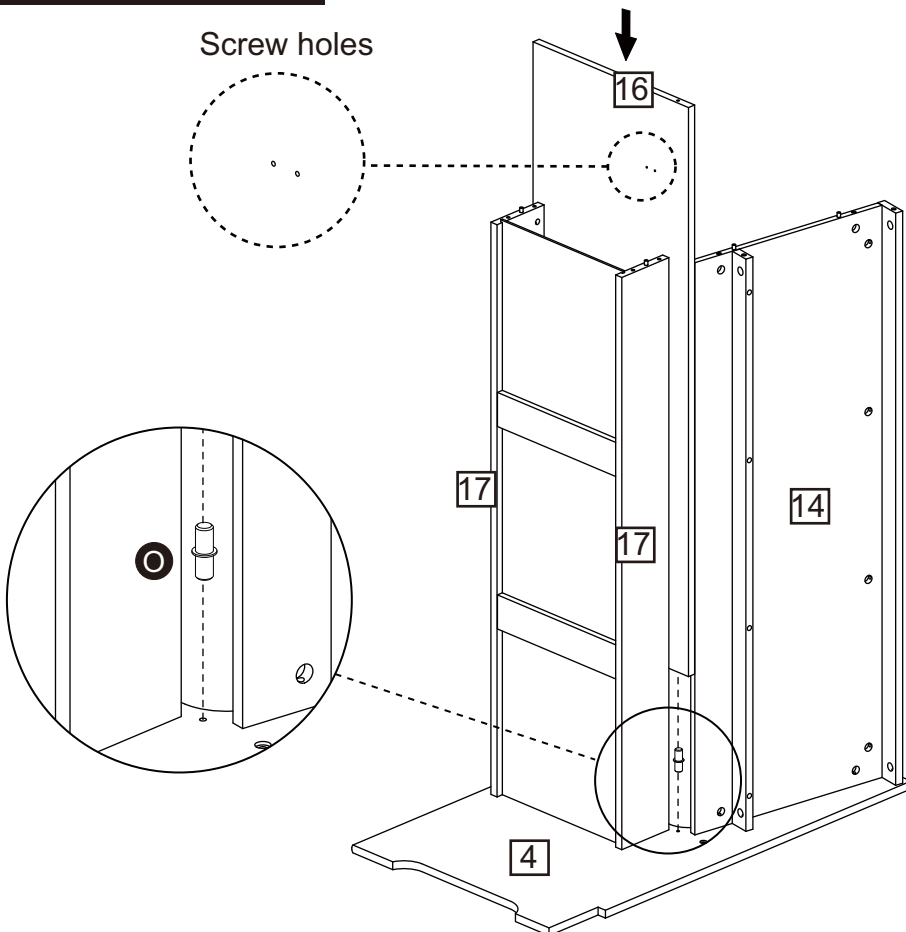

O x1

Please Insert the rotating shaft **O** between board No.16 & 4; note that the holed side of board No. 16 should face the bottom.

Assembly Instructions

Step 19

C x4



O x1



S x4



Please insert the rotating shaft o between board no.16 & 2, then lower plate 2 and tighten the eccentric wheel c.

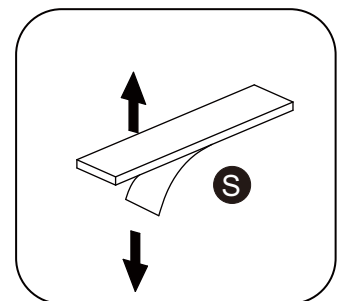
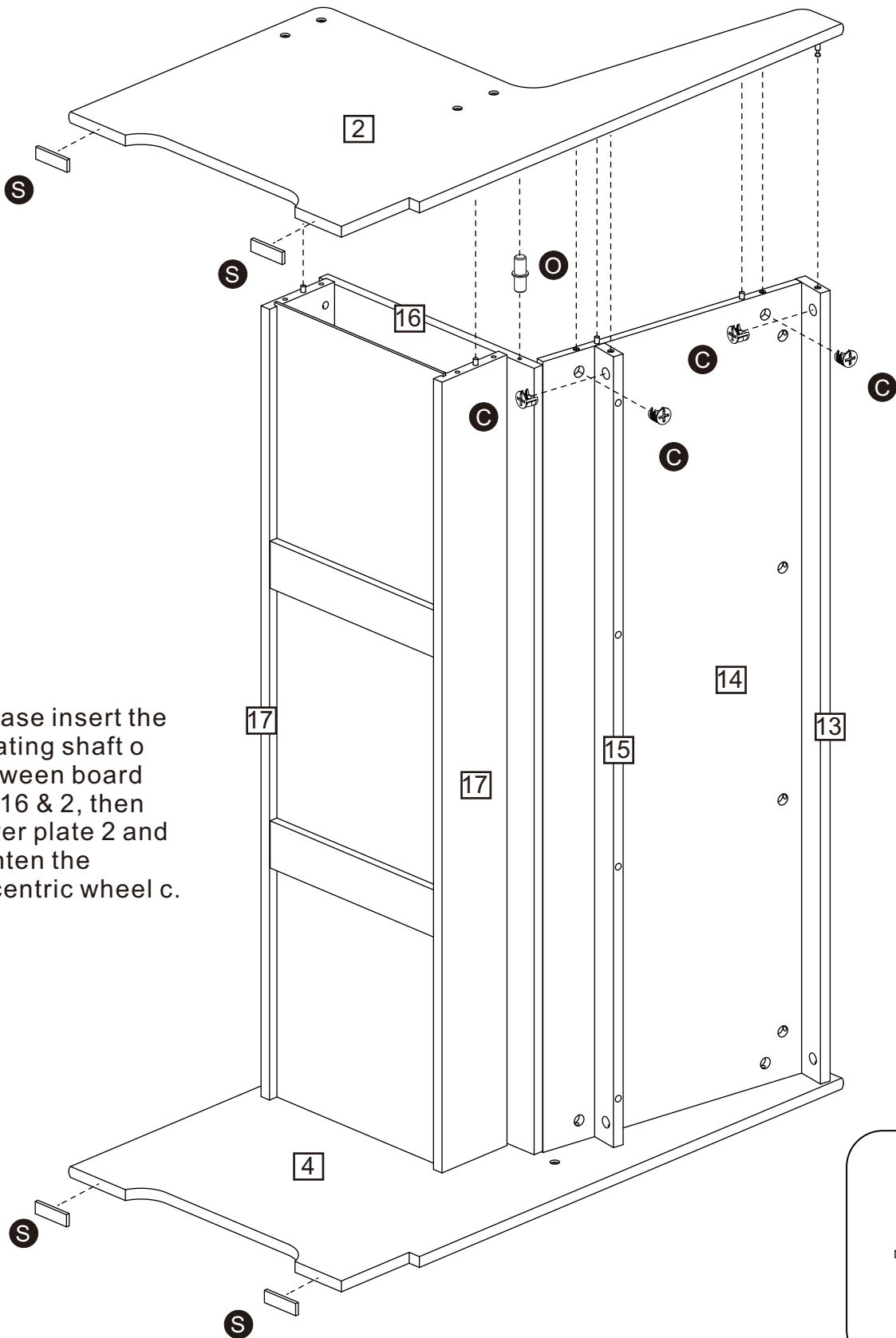

Assembly Instructions

Step 20

Please flip open cover board No. 16.

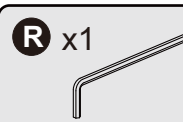
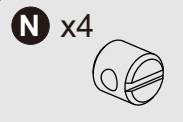
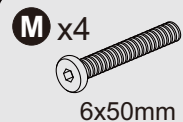
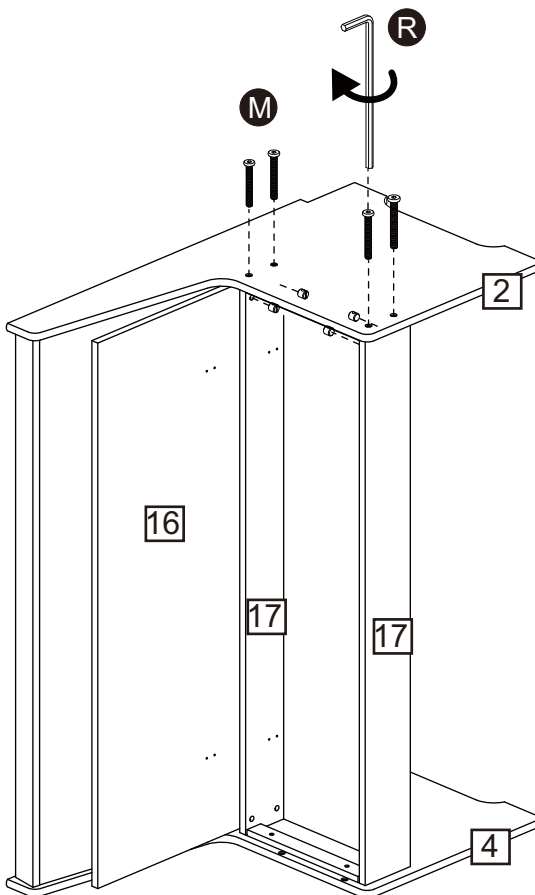
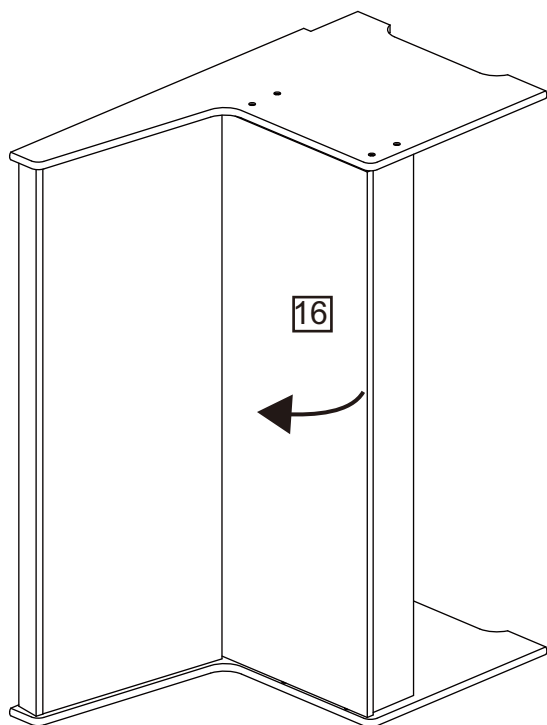

Step 21

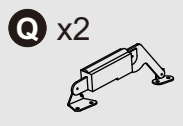
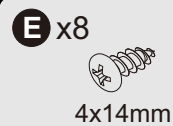
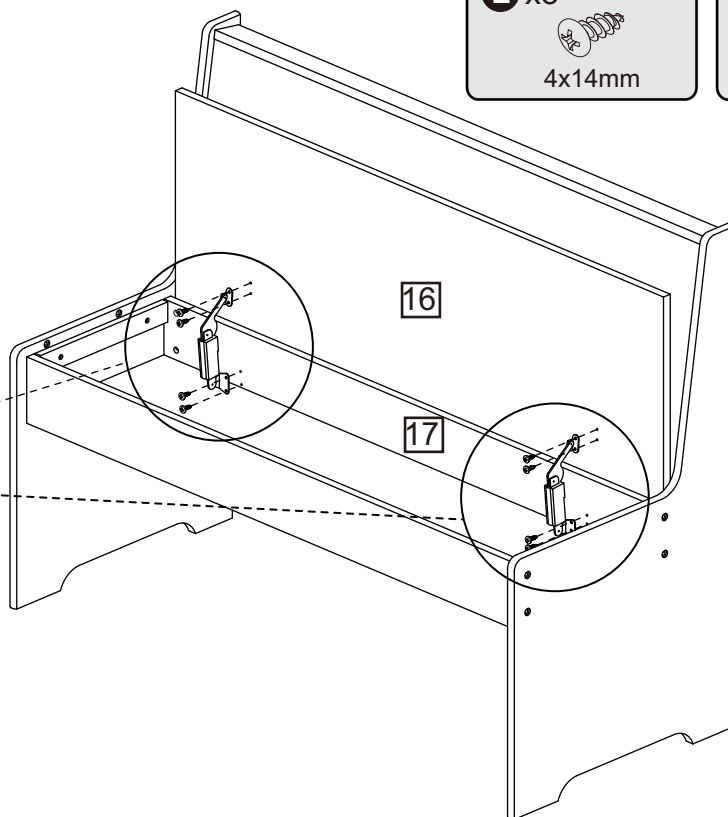
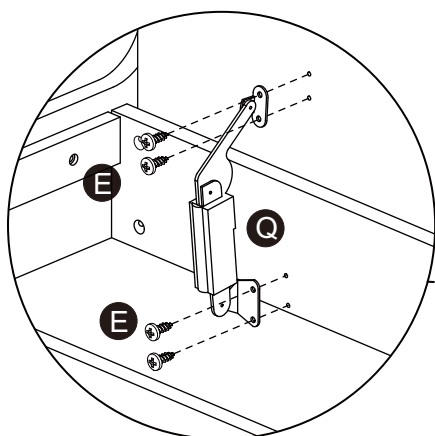

Assembly Instructions

Assembly Park C

Park C

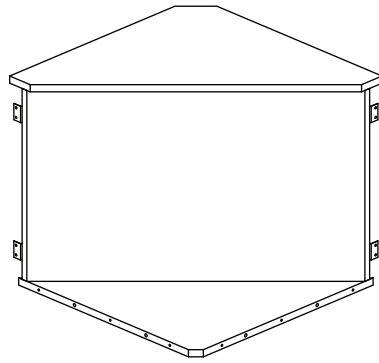

Step 22

CAM-LOCK

Tighten until shoulder is flush with panel. Do not overtighten or undertighten (see example below)

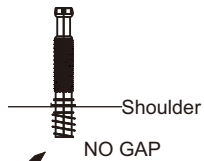
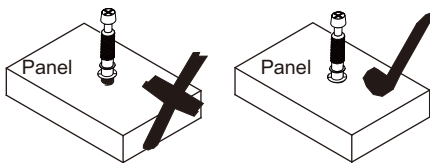

B x2

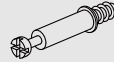

H x8



3.5x12mm

P x4

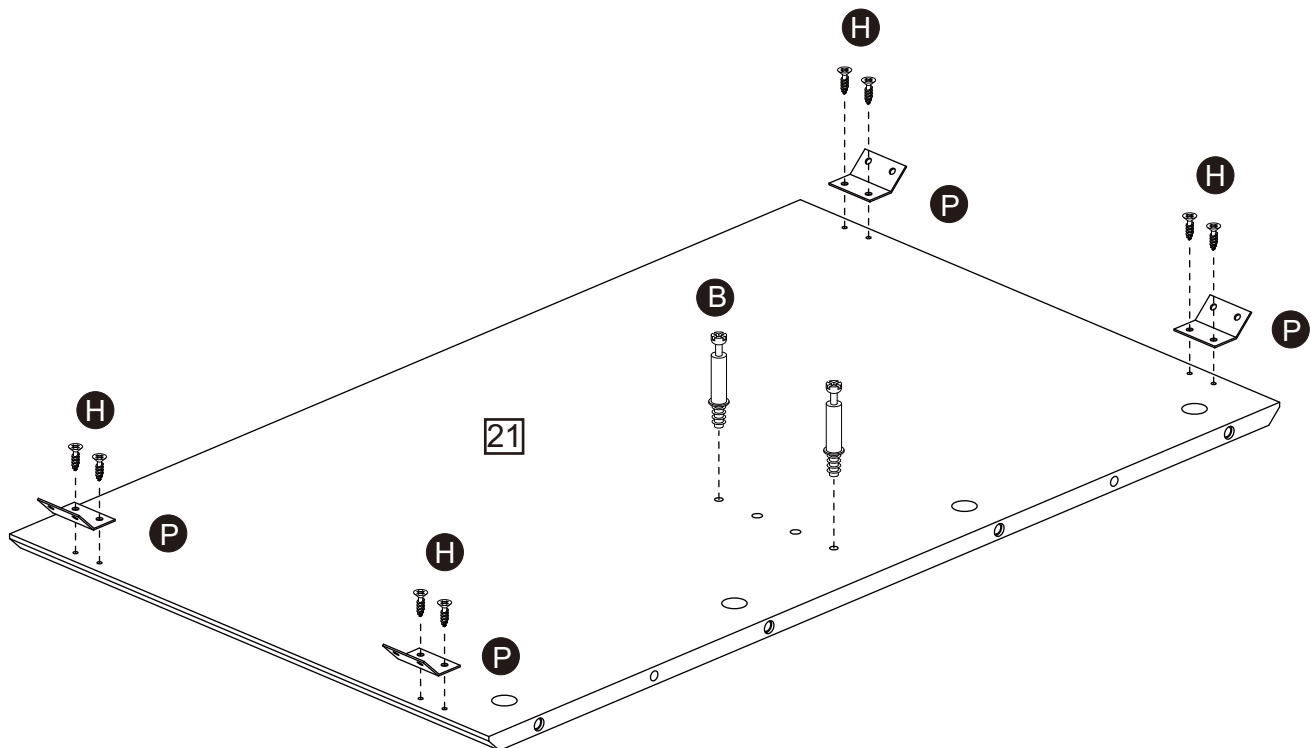

Assembly Instructions

Step 23

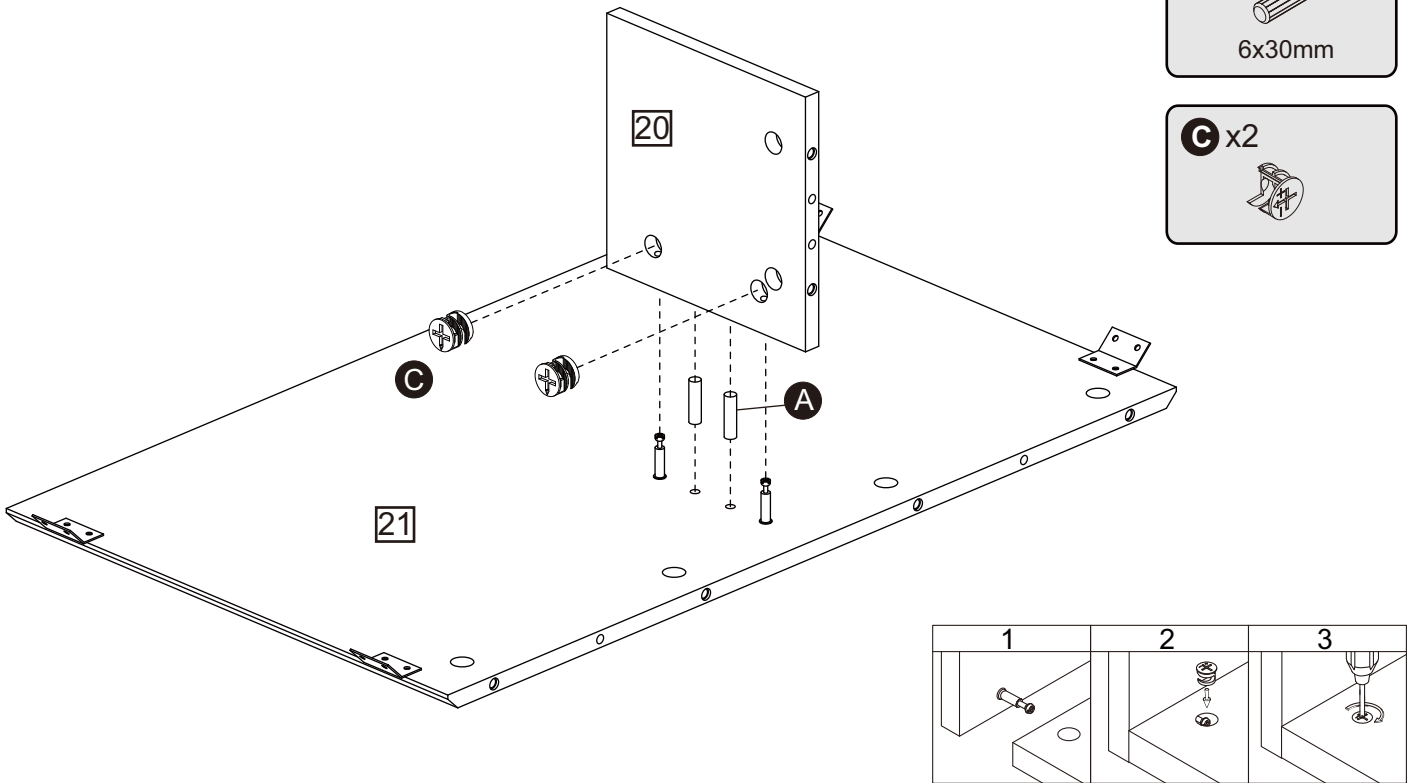

Step 24

CAM-LOCK

Tighten until shoulder is flush with panel. Do not overtighten or undertighten (see example below)

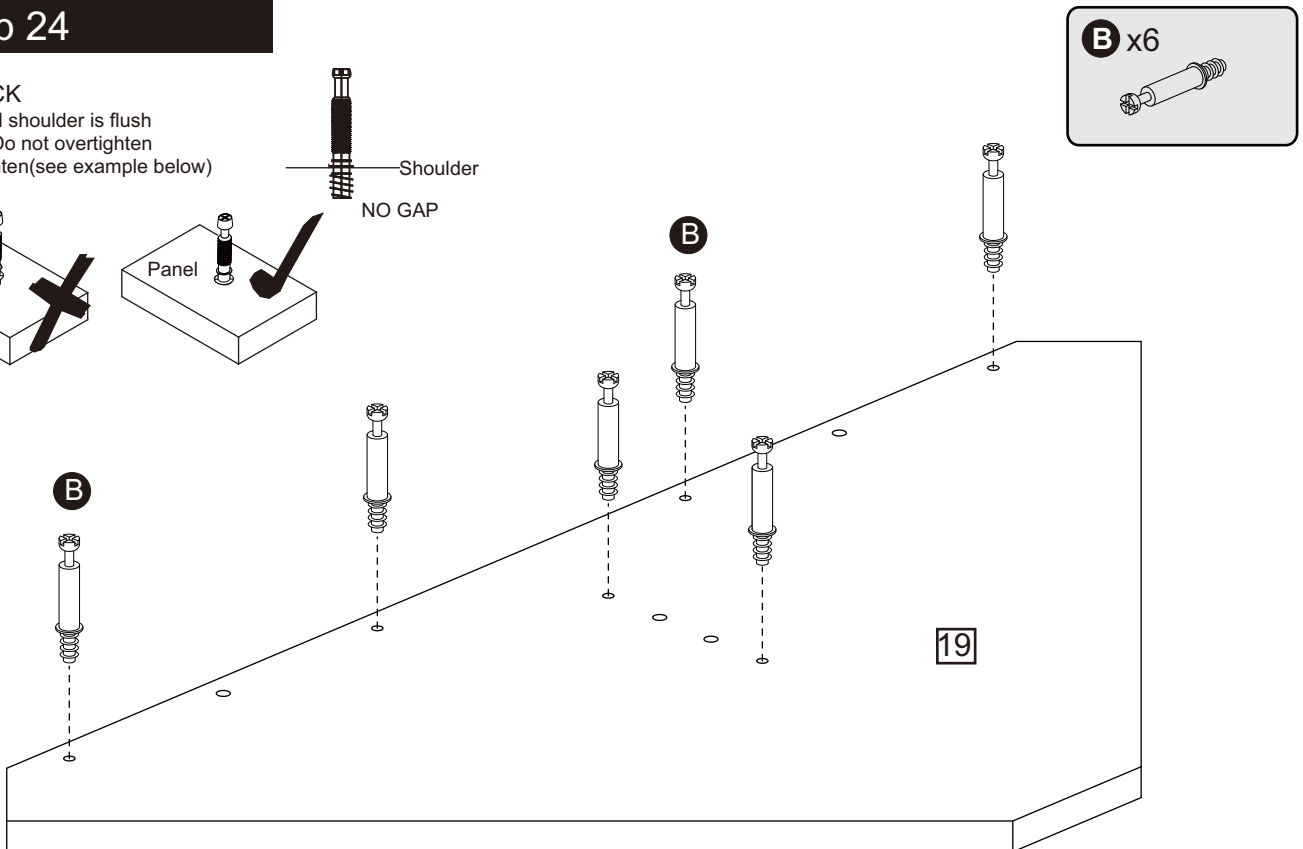
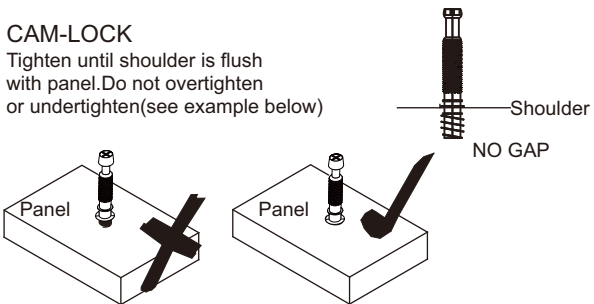

Assembly Instructions

Step 25

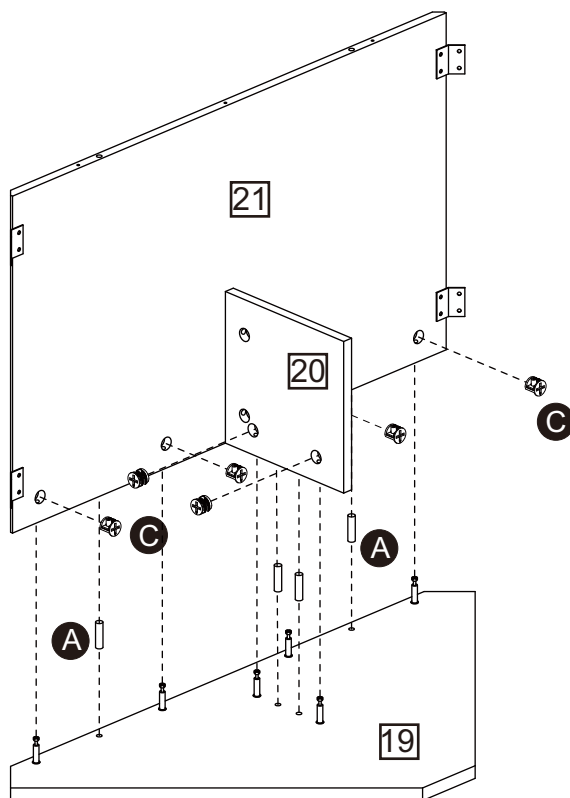

A x4



6x30mm

C x6



Step 26

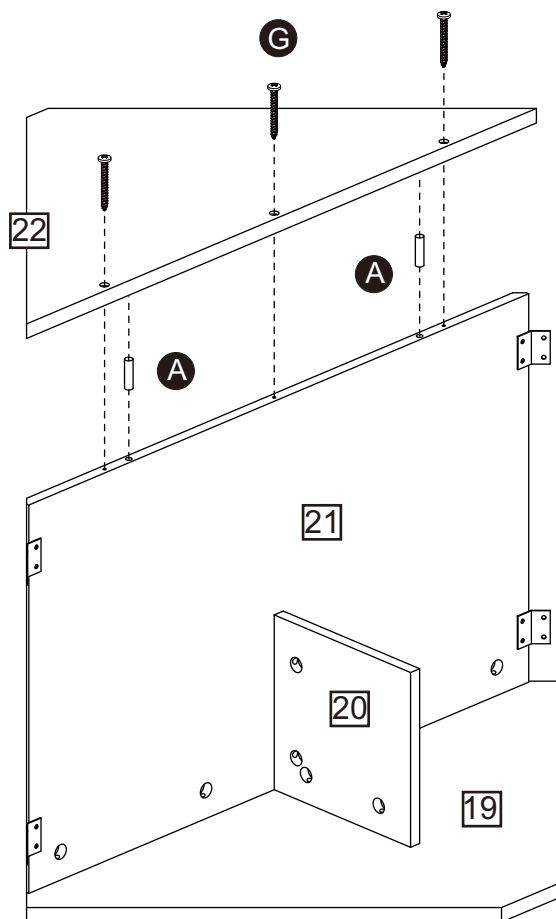

A x2



6x30mm

G x3



4x40mm

Assembly Instructions

Assembly Park A & Park B & Park C



There are two combination methods for Park A & Park B & Park C. The first one is shown on Pages 26-27; the second one is shown on Pages 28-29.

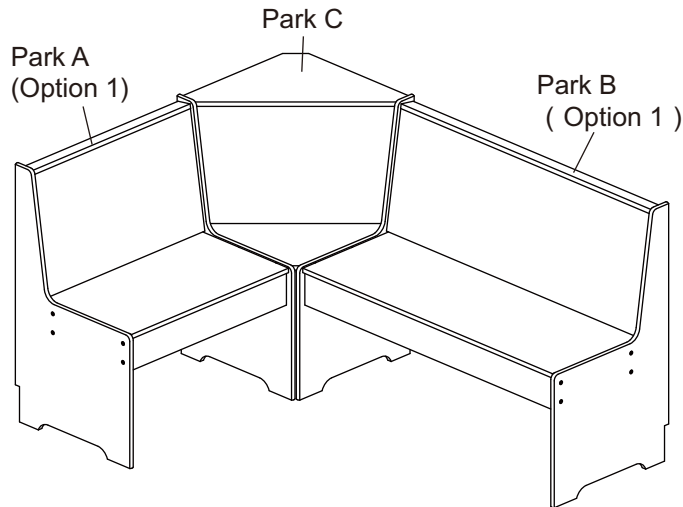

Step 27

Park A (Option 1)+Park B (Option 1)+Park C

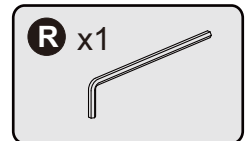
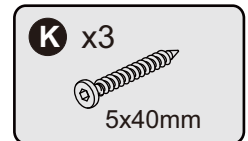
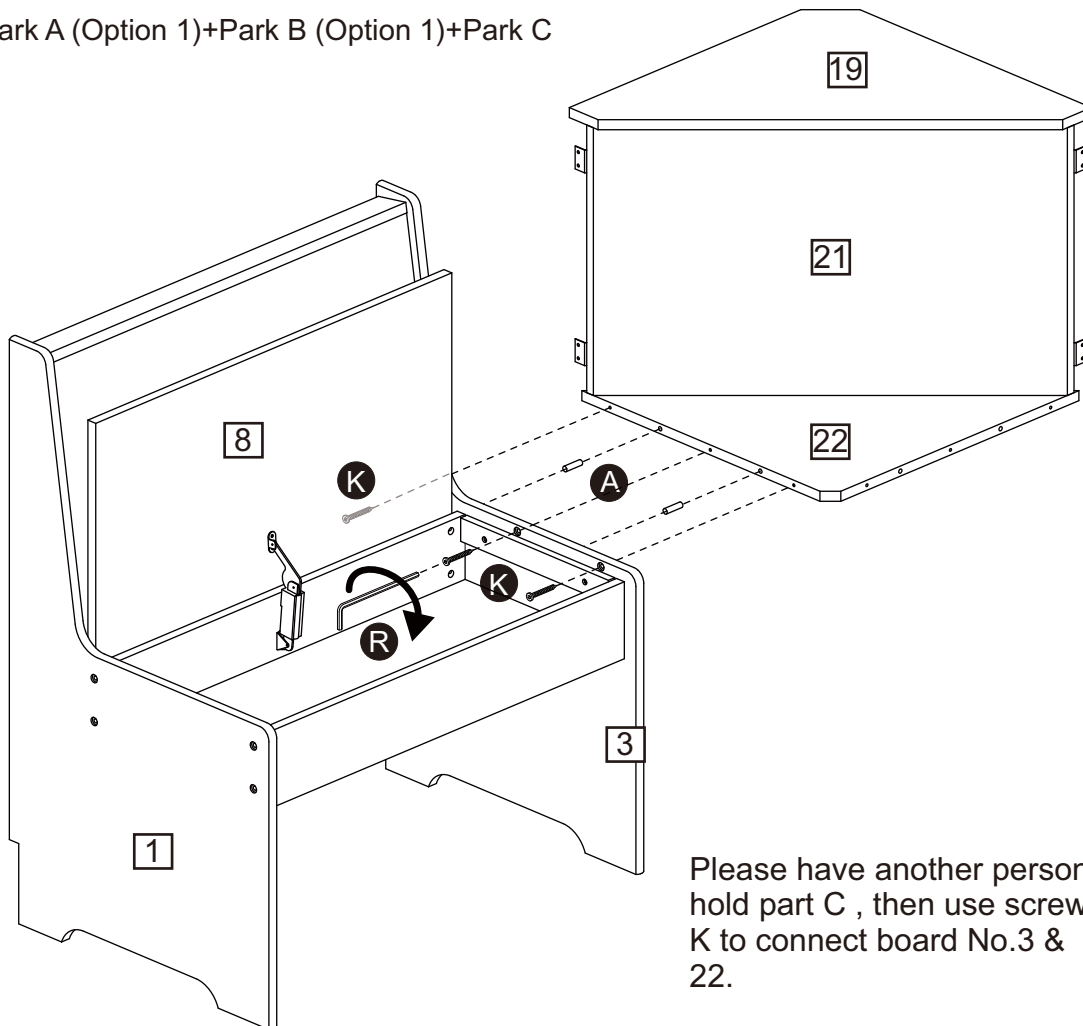

Please have another person hold part C , then use screw K to connect board No.3 & 22.

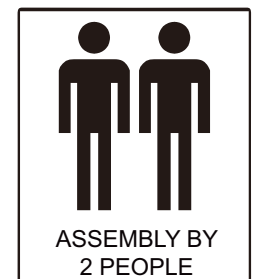

ASSEMBLY BY
2 PEOPLE

Assembly Instructions

Step 28

Park A (Option 1)+Park B (Option 1)+Park C

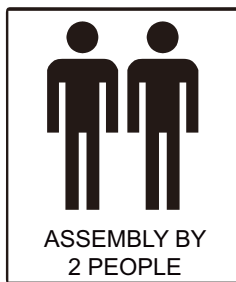
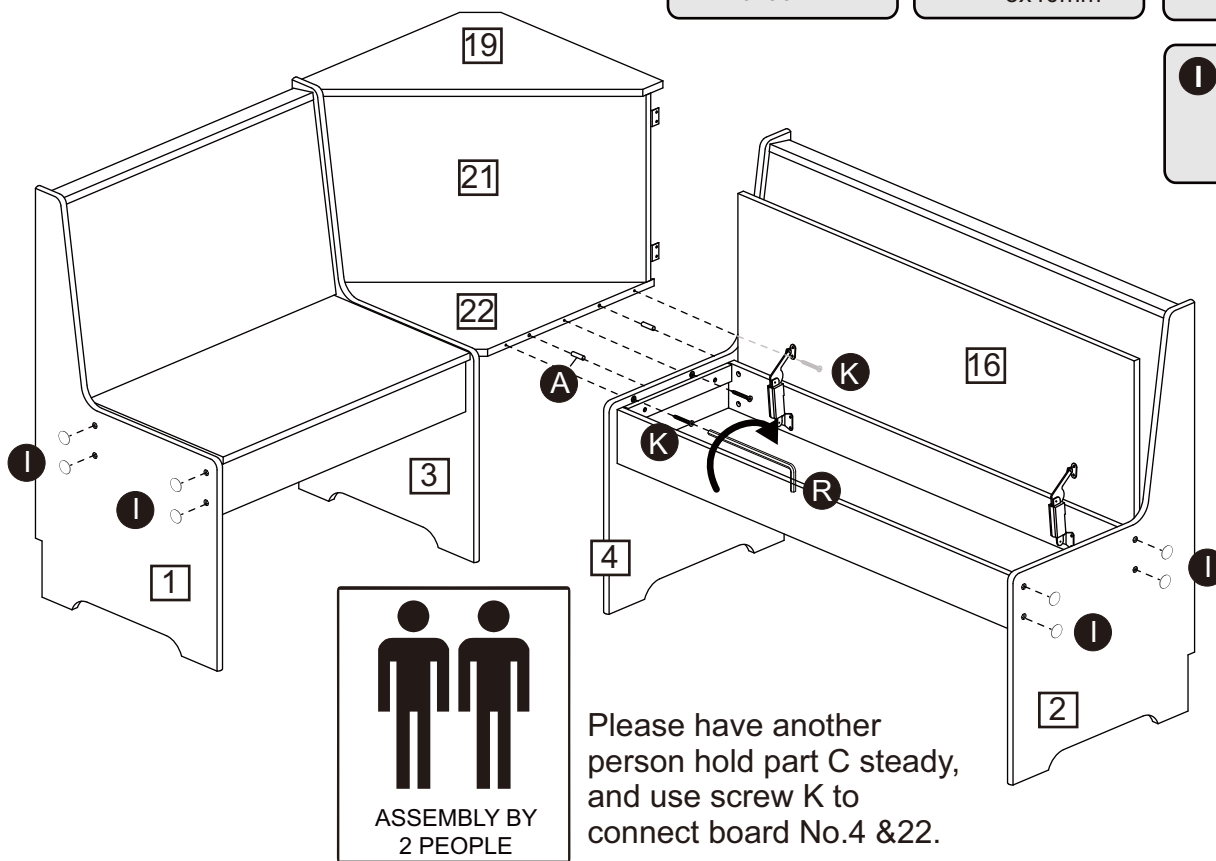
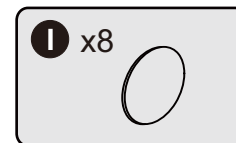
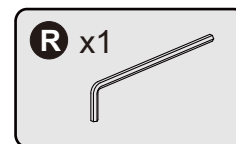

Please have another person hold part C steady, and use screw K to connect board No.4 &22.

Step 29

Park A (Option 1)+Park B (Option 1)+Park C

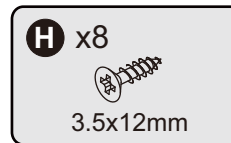

Please fasten board No. 21 to board NO. 3 & 4 with screw H on the back of the stool.

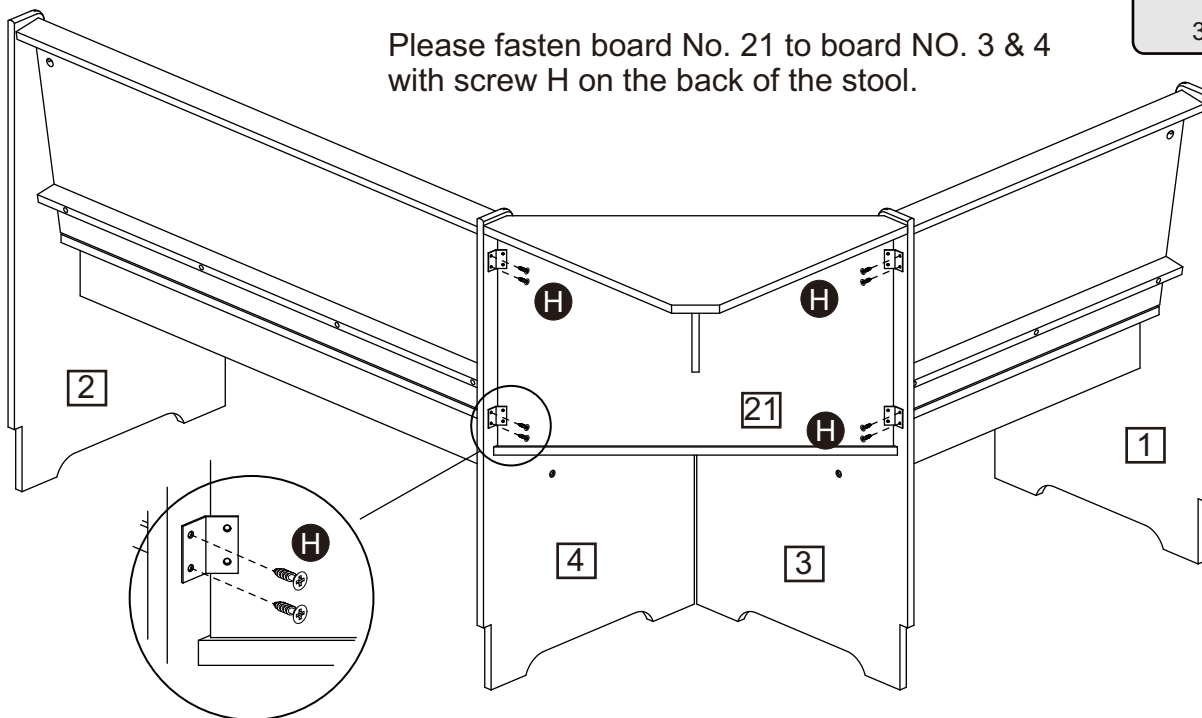

Assembly Instructions

Assembly Park A & Park B & Park C



There are two combination methods for Park A & Park B & Park C. The first one is shown on Pages 26-27; the second one is shown on Pages 28-29.

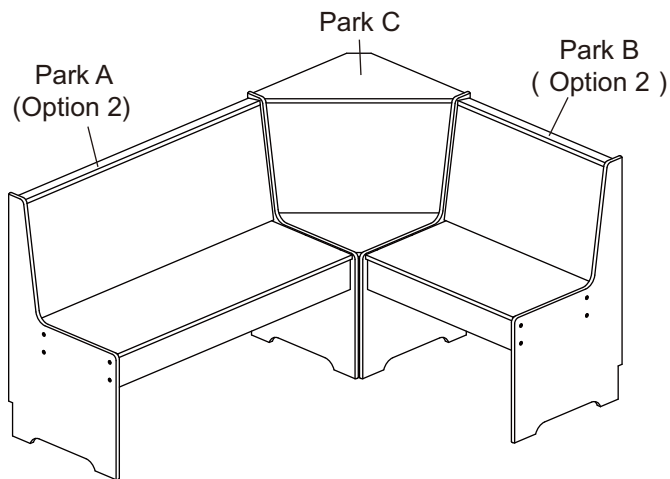

Step 27

Park A (Option 2)+Park B (Option 2)+Park C

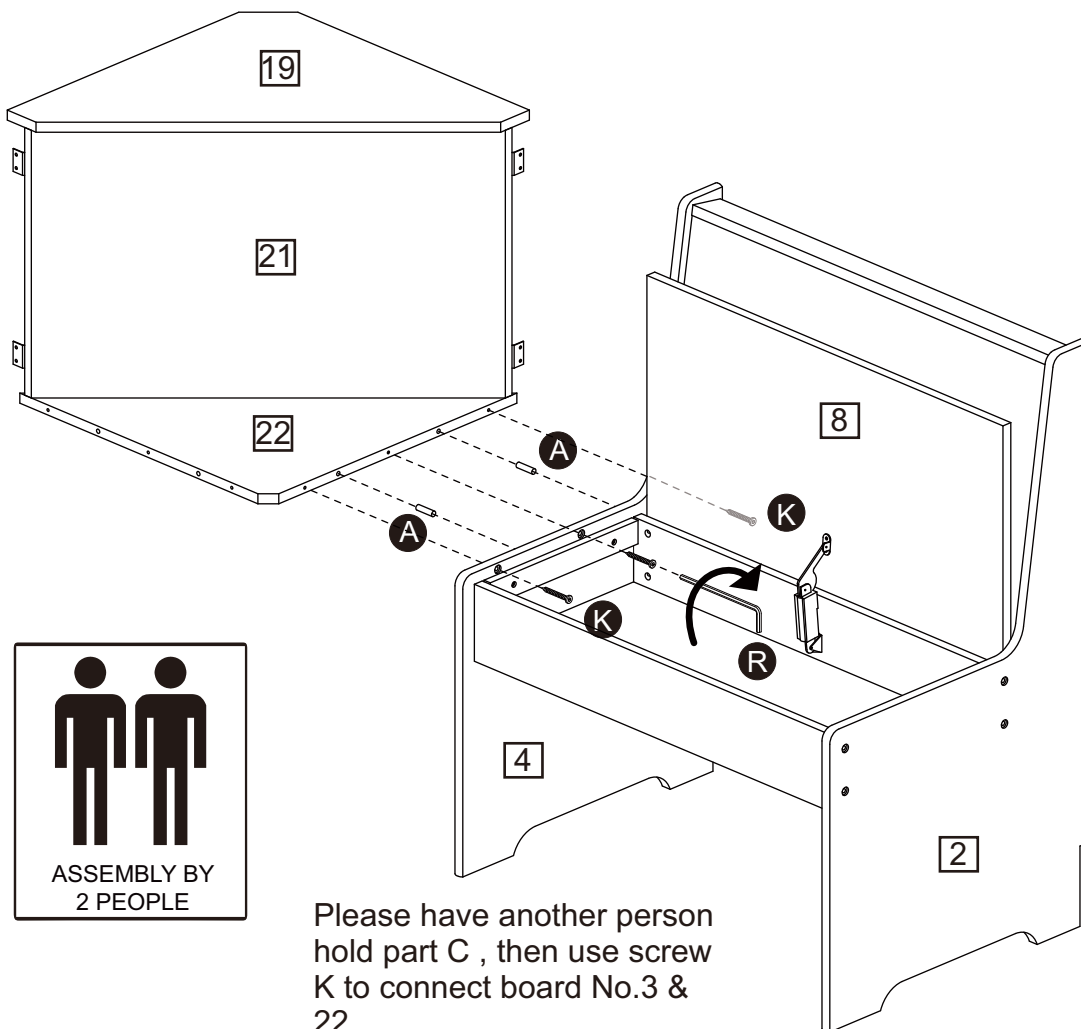
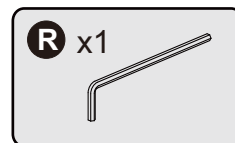

Please have another person hold part C, then use screw K to connect board No.3 & 22.

Assembly Instructions

Step 28

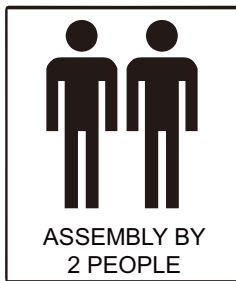

Park A (Option 2)+Park B (Option 2)+Park C

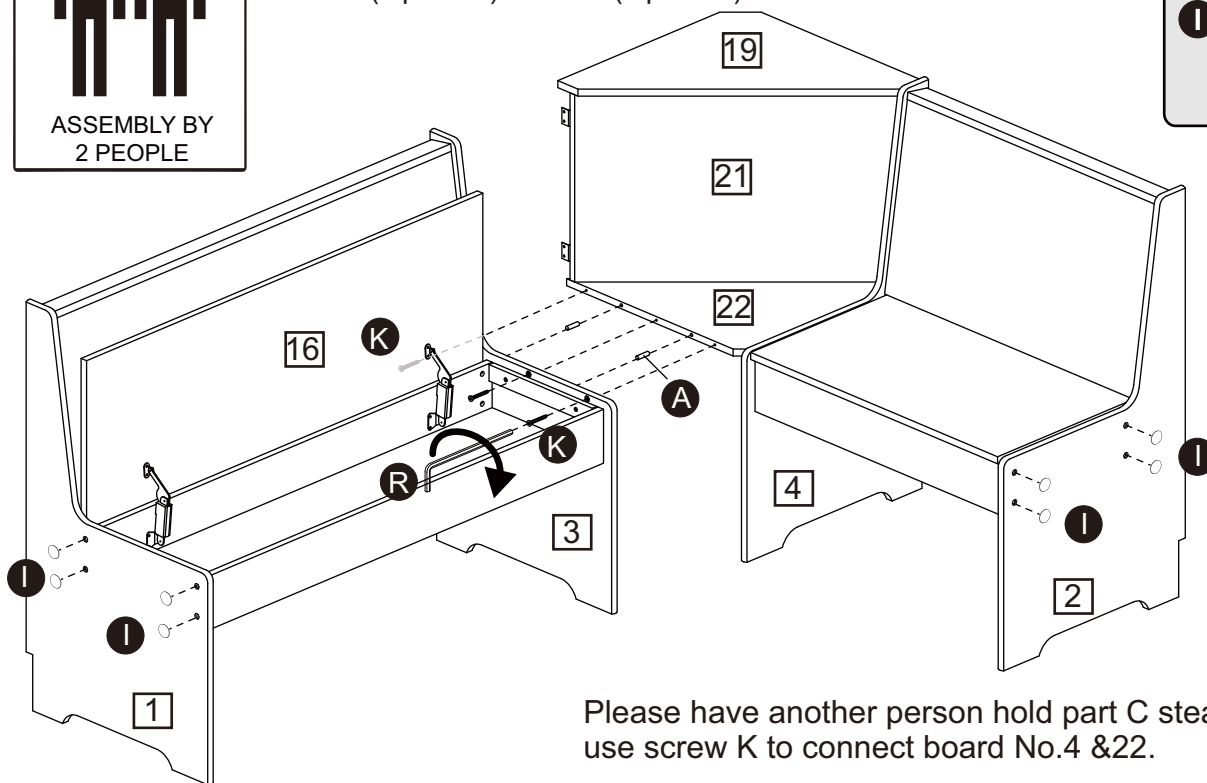
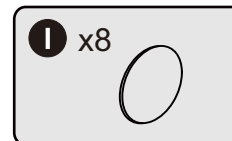
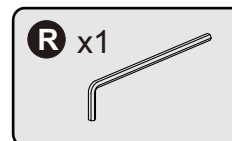

Please have another person hold part C steady, and use screw K to connect board No.4 &22.

Step 29

Park A (Option 2)+Park B (Option 2)+Park C

Please fasten board No. 21 to board NO. 3 & 4 with screw H on the back of the stool.

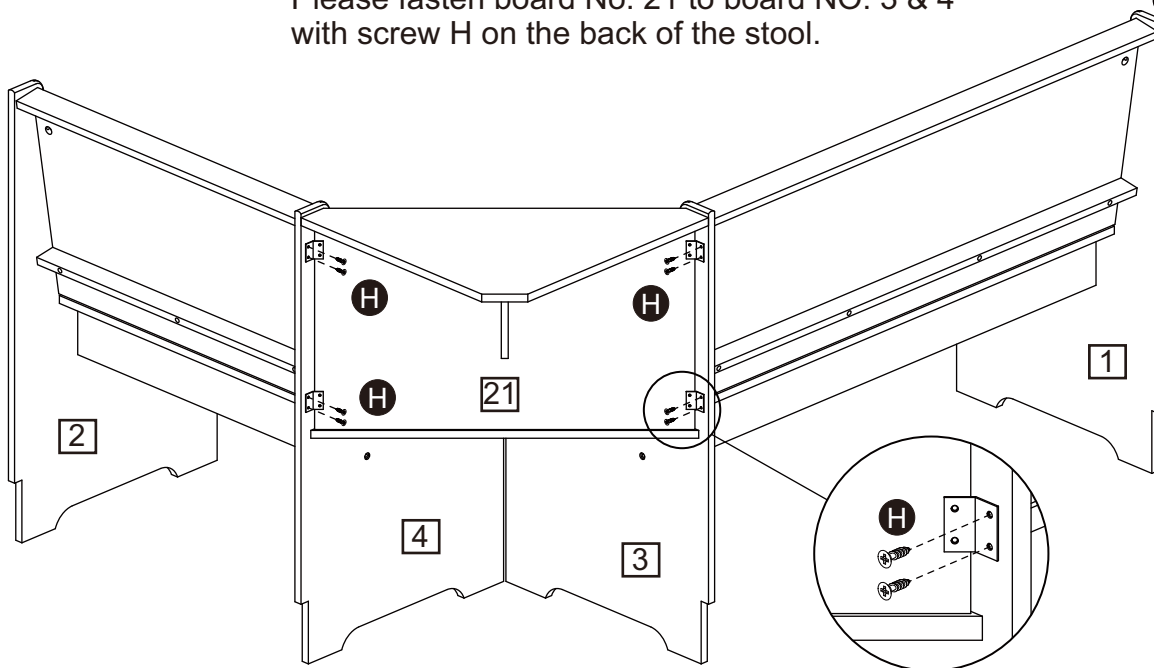
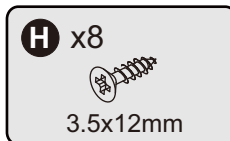

Assembly Instructions

Assembly Park D

Park D

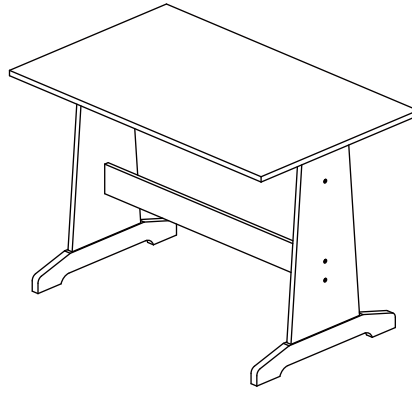

Step 30

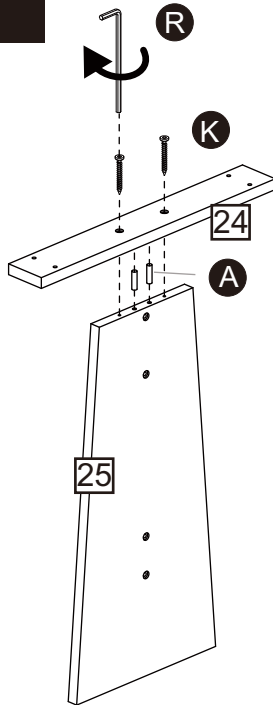
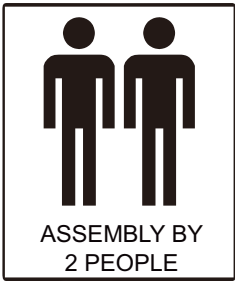

x2

Please have another person hold the side panel steady, then use screw M to fasten NO. 27 & 28 to board No. 25 in sequence.

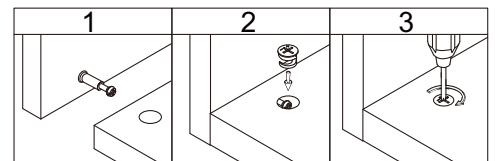
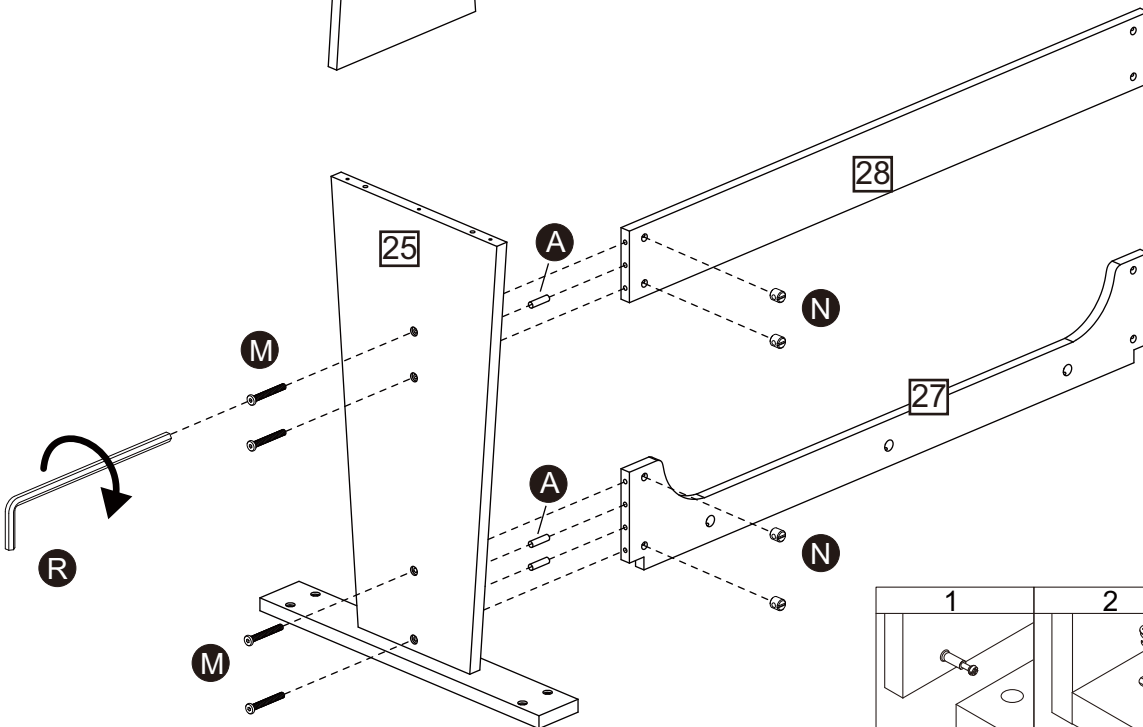
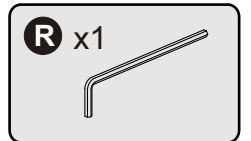
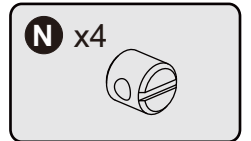
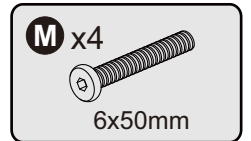
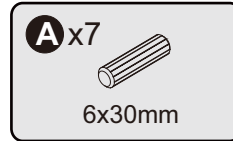

Assembly Instructions

Step 31

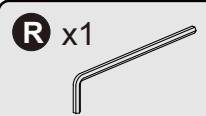
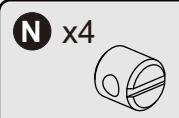
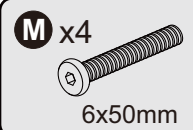
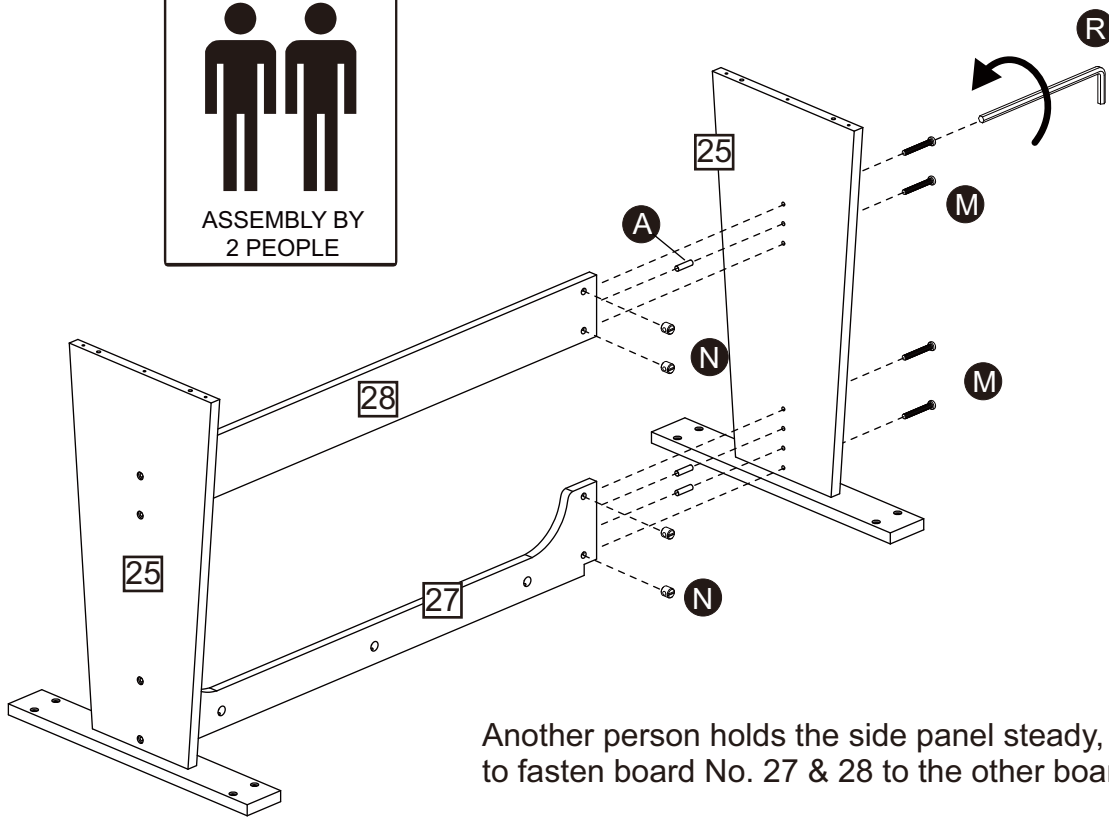
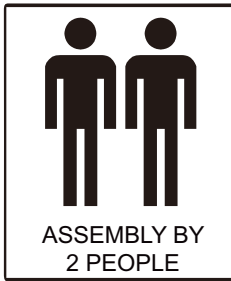

Another person holds the side panel steady, then use screw M to fasten board No. 27 & 28 to the other board No. 25.

Step 32

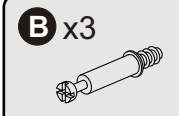
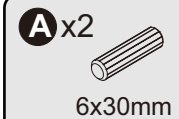
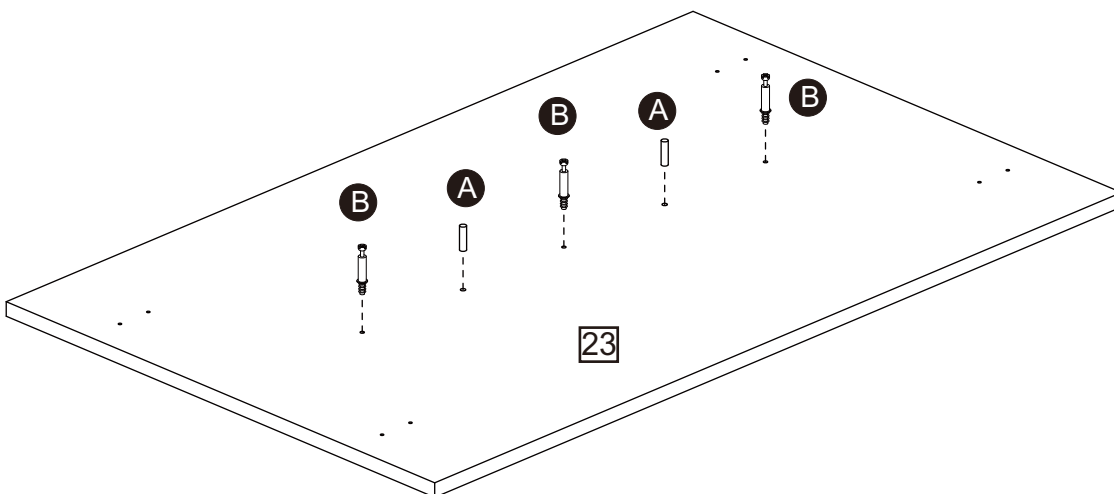

Assembly Instructions

Step 33

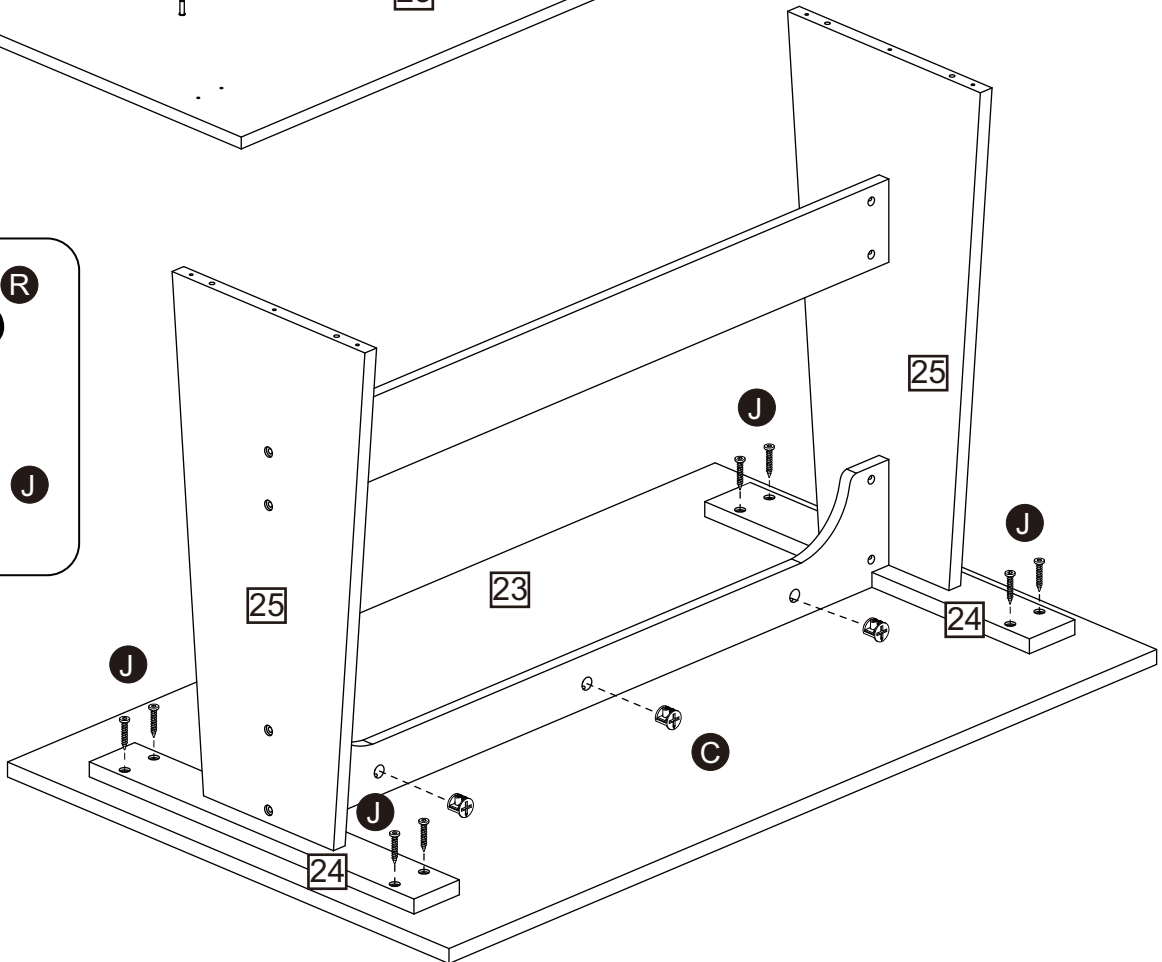
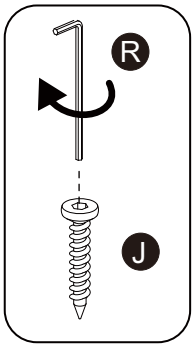
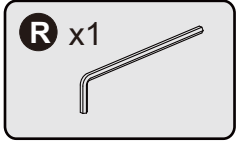
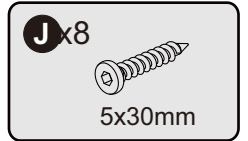
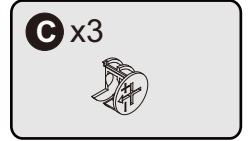
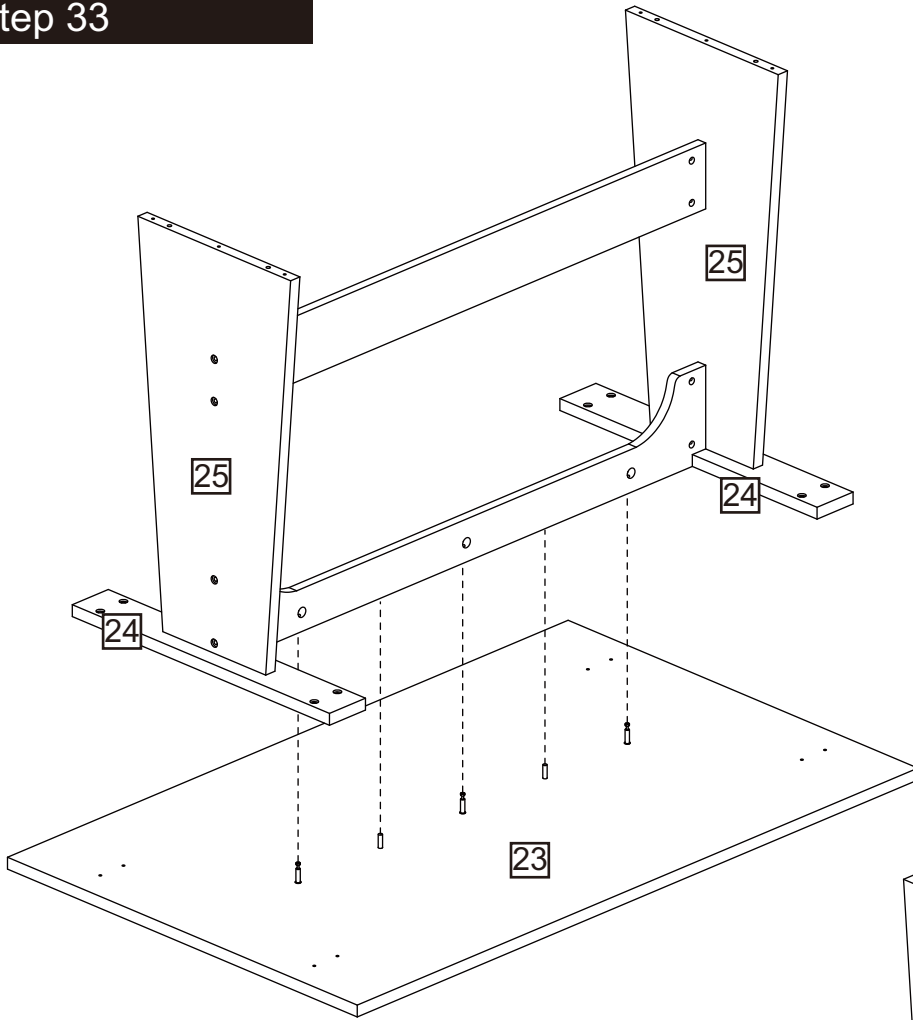

Assembly Instructions

Step 34

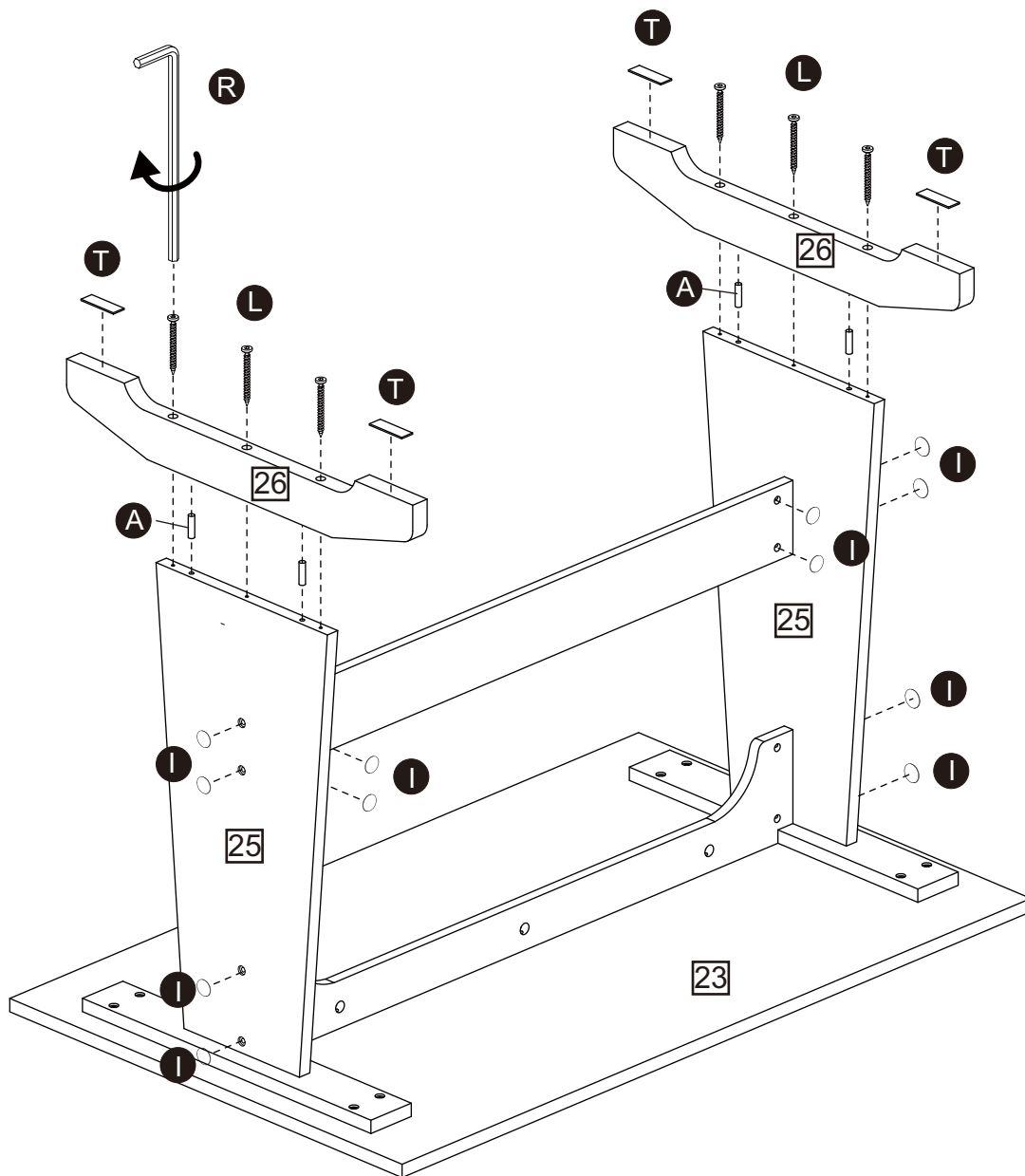
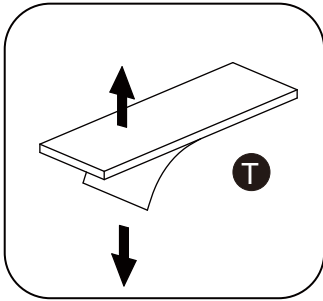
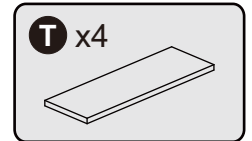
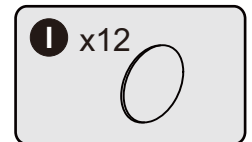
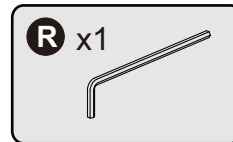
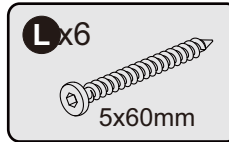
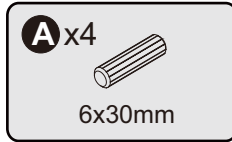

Assembly Instructions

Assembly Park E

Park E

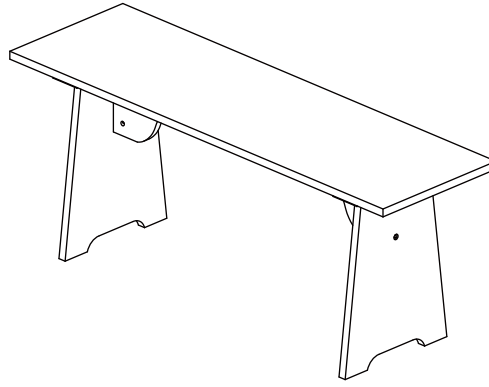

Step 35

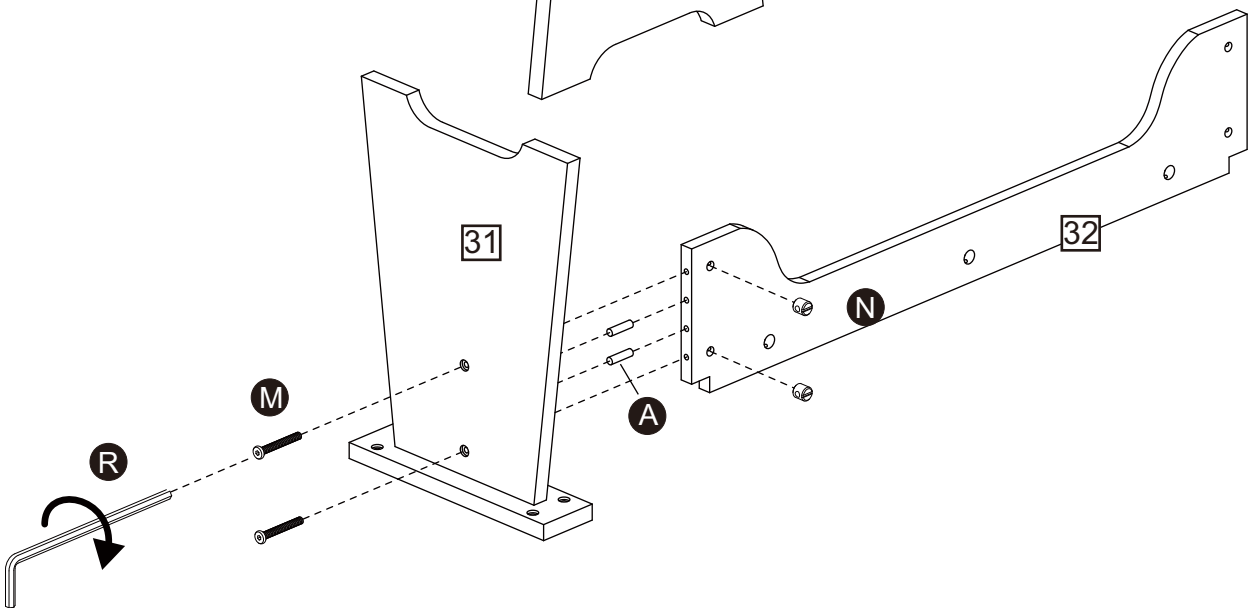
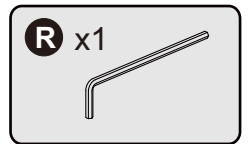
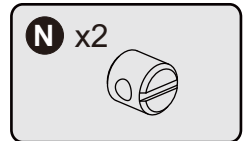
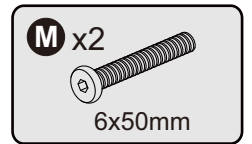
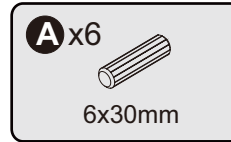
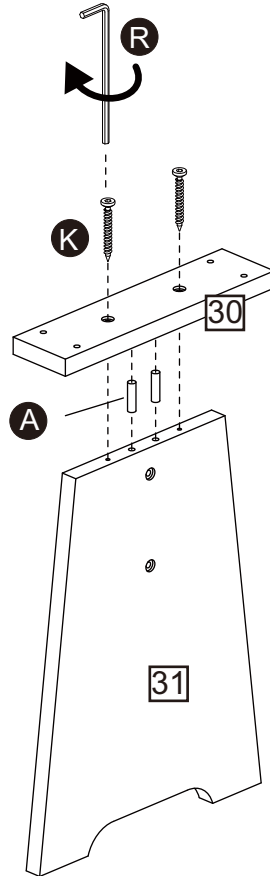

Assembly Instructions

Step 36

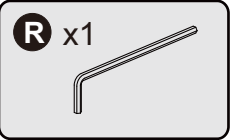
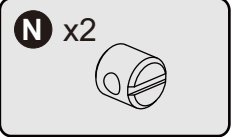
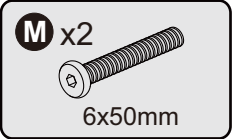
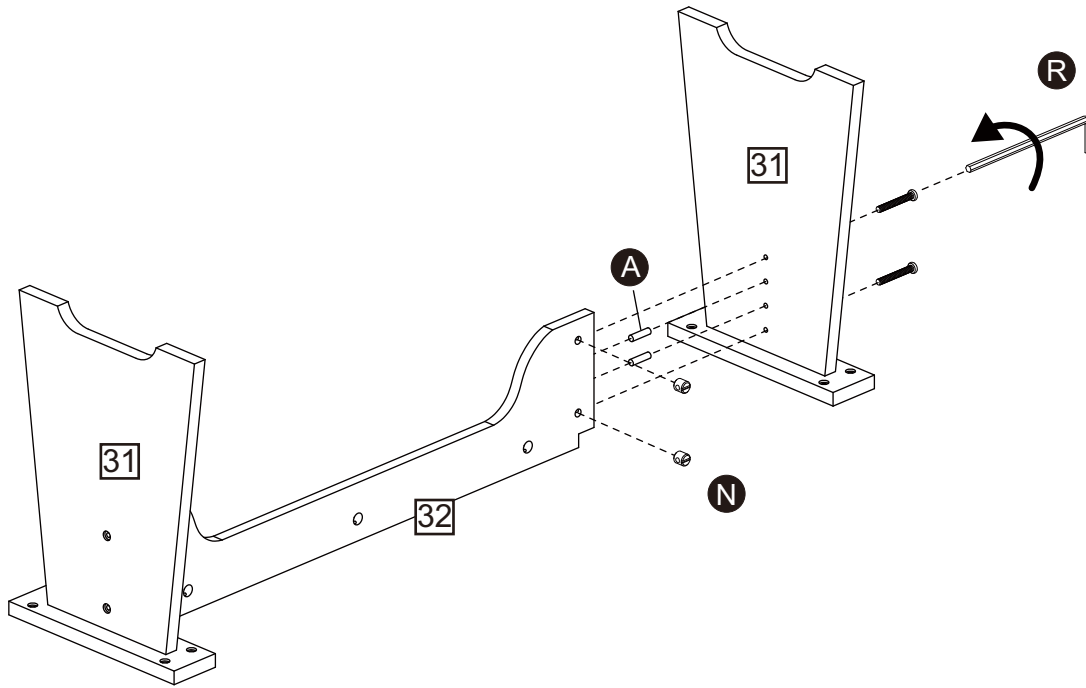

Step 37

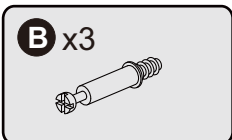
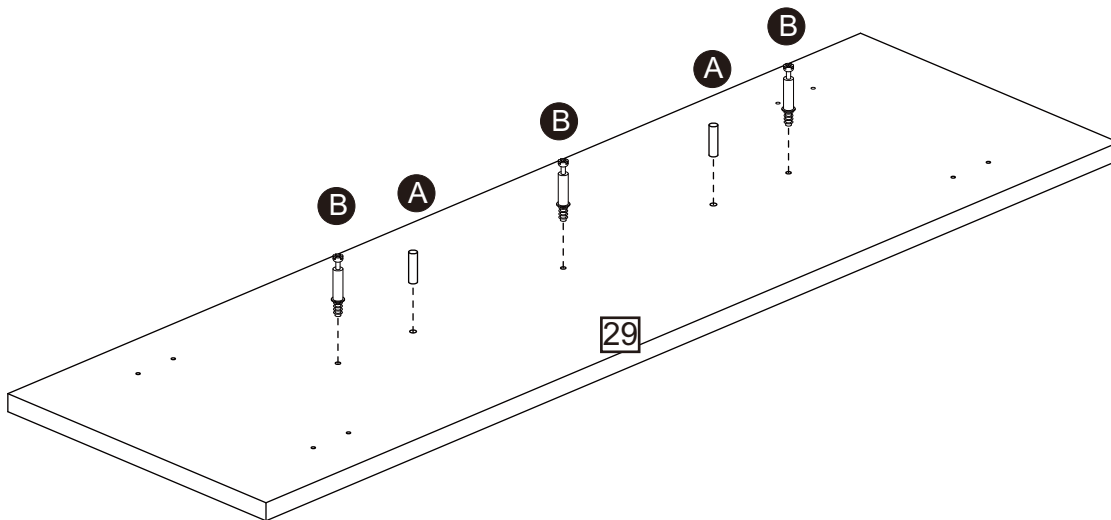

Assembly Instructions

Step 38

