

Greenhouse 6X4FT

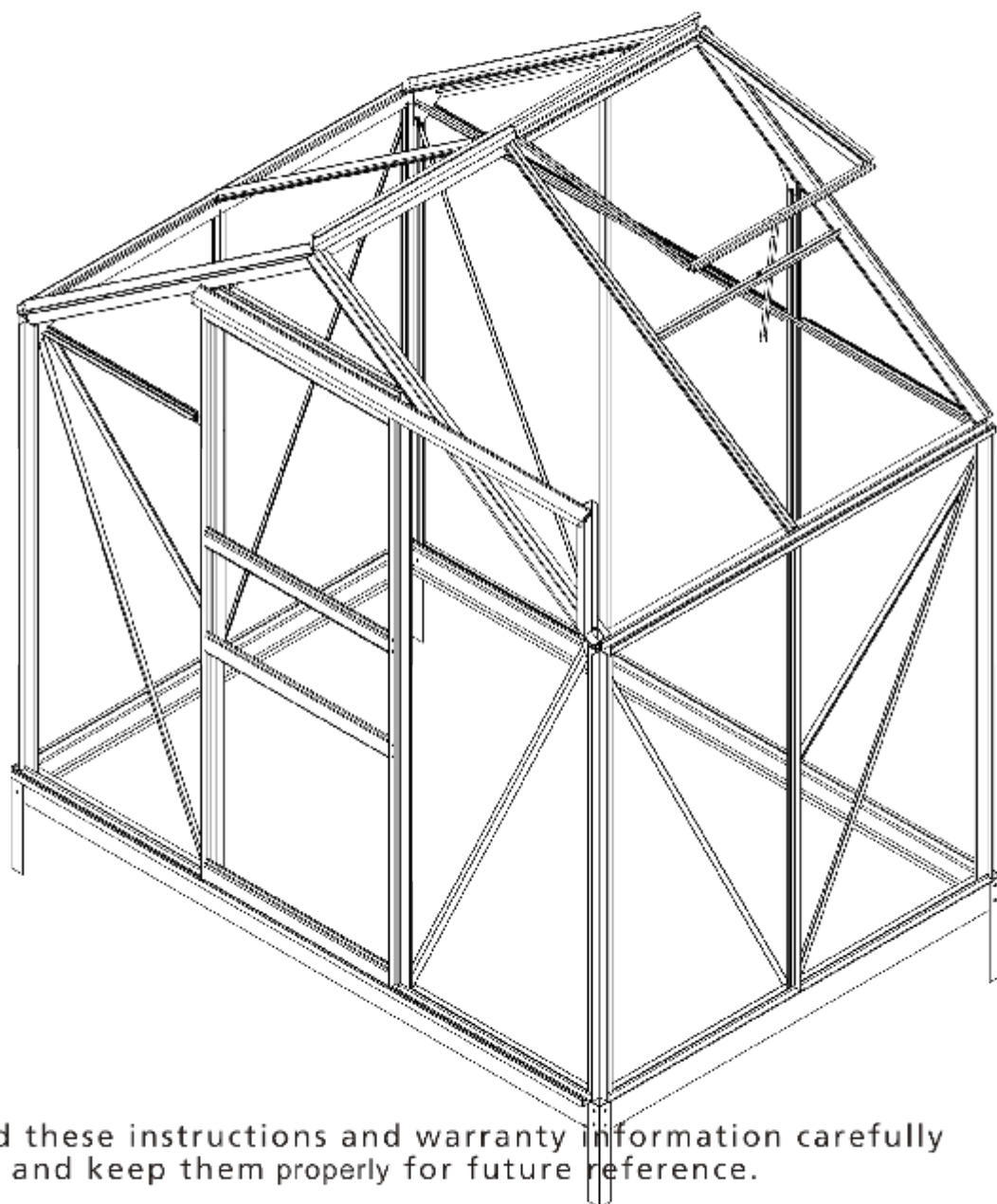

Please read these instructions and warranty information carefully before use and keep them properly for future reference.

OPERATING INSTRUCTIONS

TO PREVENT INJURY, READ AND UNDERSTAND THE GREENHOUSE ASSEMBLY INSTRUCTIONS BEFORE USE.

Notes:

1. It takes about 2-3 hours to assemble the greenhouse by 2-3 persons.
2. The UV-protected side of the sheet is covered with opal white film and must face towards the sun.
3. Remove approximately 2 inches of film from all sheet edges before installing. Removing all film immediately after the construction is completed
4. Make sure the greenhouse is located on a flat, level surface.

GENERAL SAFETY, WARNINGS AND PRECAUTIONS

KEEP WORK AREA CLEAN AND DRY.

Cluttered, damp or wet work areas invite injuries.

STAY ALERT. Watch what you are doing at all times. Use common sense. Do not use the greenhouse when you are tired or distracted from the job at hand. It is recommended to use gloves for assembling the greenhouse.

MAINTAIN THIS PRODUCT WITH CARE.

Keep the greenhouse clean and dry for better performance: maintenance should be performed regularly.

USE THE RIGHT PRODUCT FOR THE JOB.

Do not attempt to force a small product to do the work of a larger industrial product. There are certain applications for which the greenhouse was designed. It will do the job better and more safely in the manner for which it was intended. Do not modify the greenhouse and do not use the greenhouse for a purpose for which it was not intended.

MAINTAIN A SAFE WORKING ENVIRONMENT.

Keep the work area tidy. Make sure there is adequate surrounding workspace. Avoid high traffic areas. Always keep the work area free of obstructions, grease, oil, trash and other debris.

PROPER GREENHOUSE LOCATION.

Make sure the greenhouse is located on a flat, level surface.

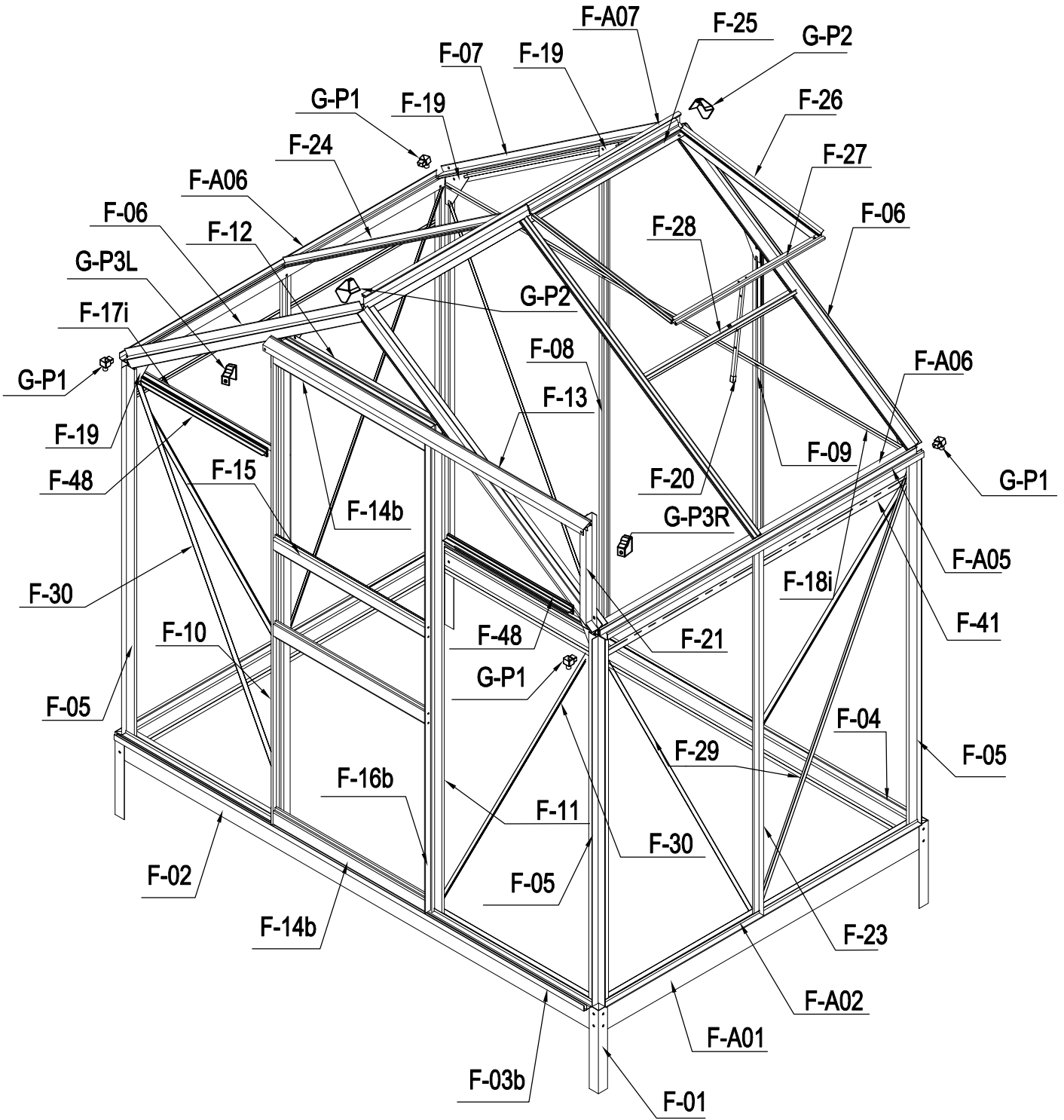

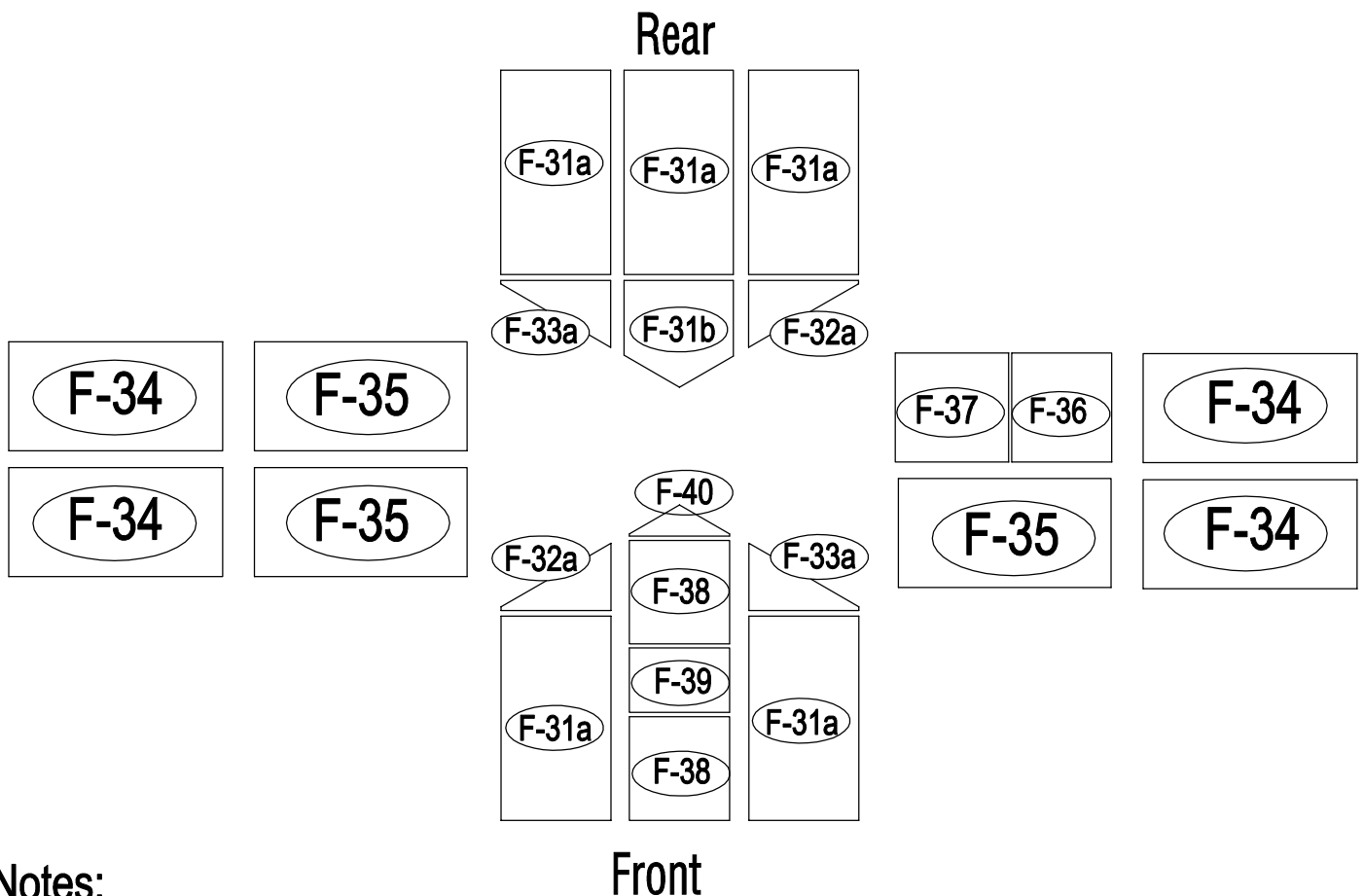





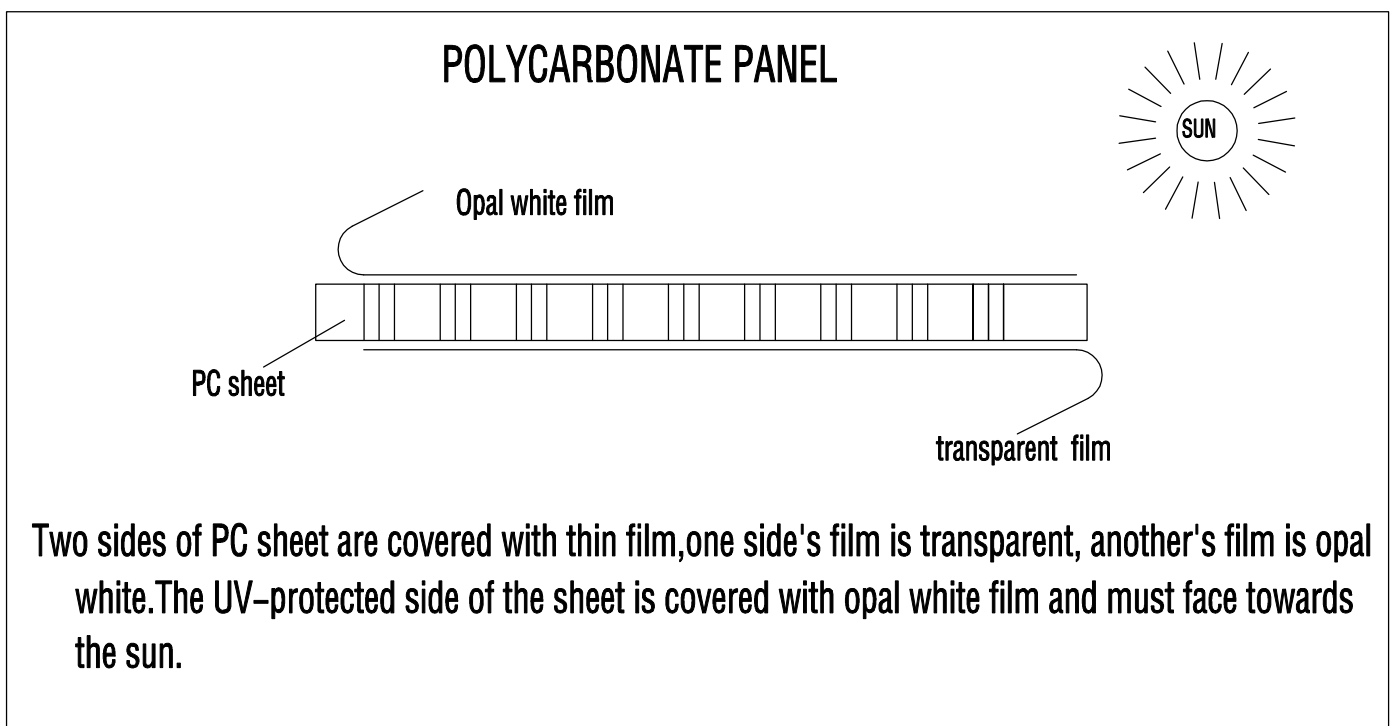





















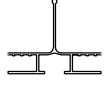

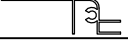
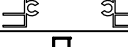











Notes:

1. Remove approximately 2 inches of film from all sheet edges before installing. remove all film immediately after the constructions completed.
2. The UV-protected side of the sheet is covered with opal white film and must face towards the sun.





Two sides of PC sheet are covered with thin film, one side's film is transparent, another's film is opal white. The UV-protected side of the sheet is covered with opal white film and must face towards the sun.



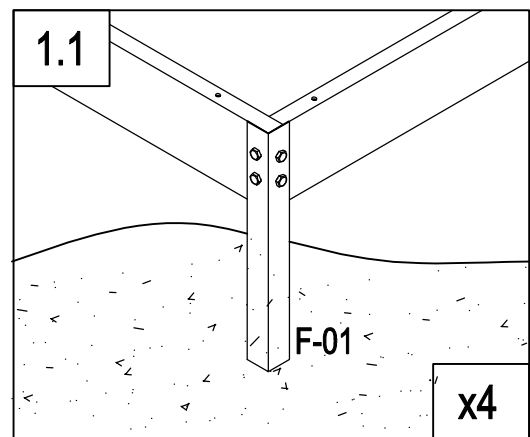
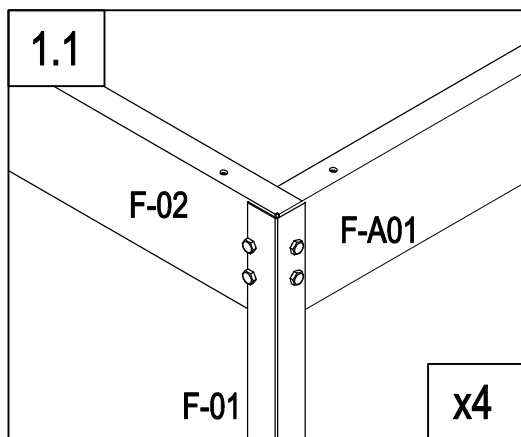
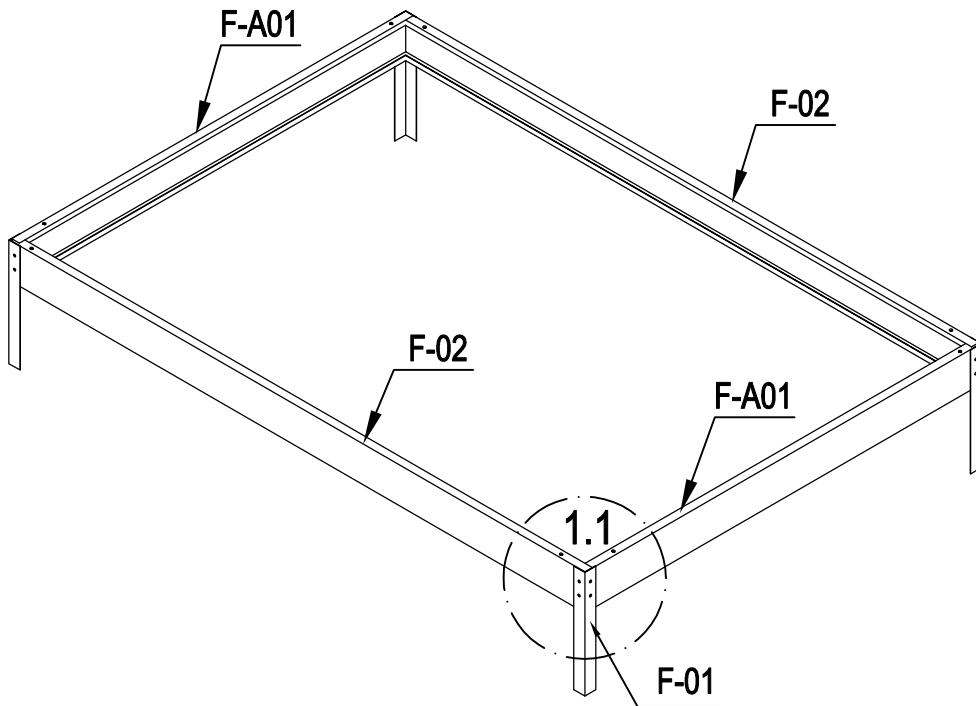

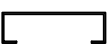
PARTS LIST

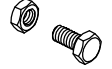
BASE				WINDOW			
IMAGE	NO.	L.	QTY	IMAGE	NO.	L.	QTY
	F-01	280	4		F-20	360	1
	F-02	1882	2		F-25	580	1
	F-A01	1282	2		F-26	550	2
	F-03b	1833	1		F-27	580	1
	F-04	1833	1		F-28	620	1
	F-A02	1233	2		F-37	577x583	1
	F-A13		14	SCREW			
WALL AND ROOF				SCREW			
IMAGE	NO.	L.	QTY	IMAGE	NO.	L.	QTY
	F-05	1240	4		F-A14		128
	F-06	1105	2		F-A15a		12
	F-07	1105	2		F-A16		6
	F-08	1650	1	DOOR			
	F-09	1650	1		F-12	572.5	1
	F-23	1240	2		F-13	1240	1
	F-24	1100	2		F-14b	600	2
	F-48	568	5		F-15	600	2
	F-10	1644	1		F-16b	1615	2
	F-11	1644	1		F-21	376	1
	F-A05	1236	2		F-22b		4
	F-A06	1233	2		F-38	590x598	2
	F-17i	618	2		F-39	251x598	1
	F-18i	1815	1	PLASTIC			
	F-41	1216	2		G-P1		4
	F-29	1360	4		G-P2		2
	F-30	1328	4		G-P3L		1
	F-A07	1233	1		G-P3R		1
	F-31a	1217x585	5				
	F-31b	618x585	1				
	F-32a	412x585	2				
	F-33a	412x585	2				
	F-34	1238x585	4				
	F-35	1110x585	3				
	F-36	540x585	1				
	F-40		1				
	F-19		8				

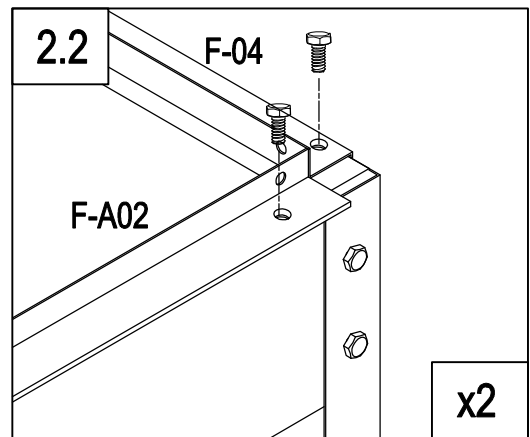
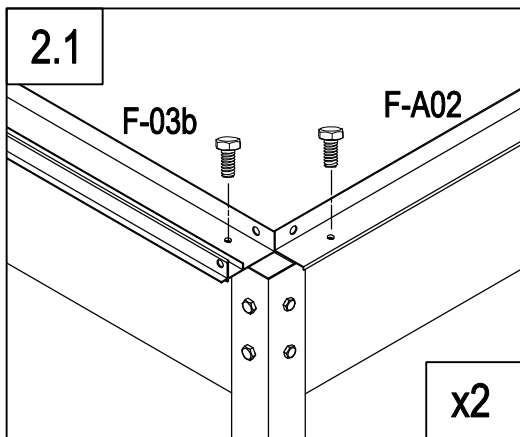
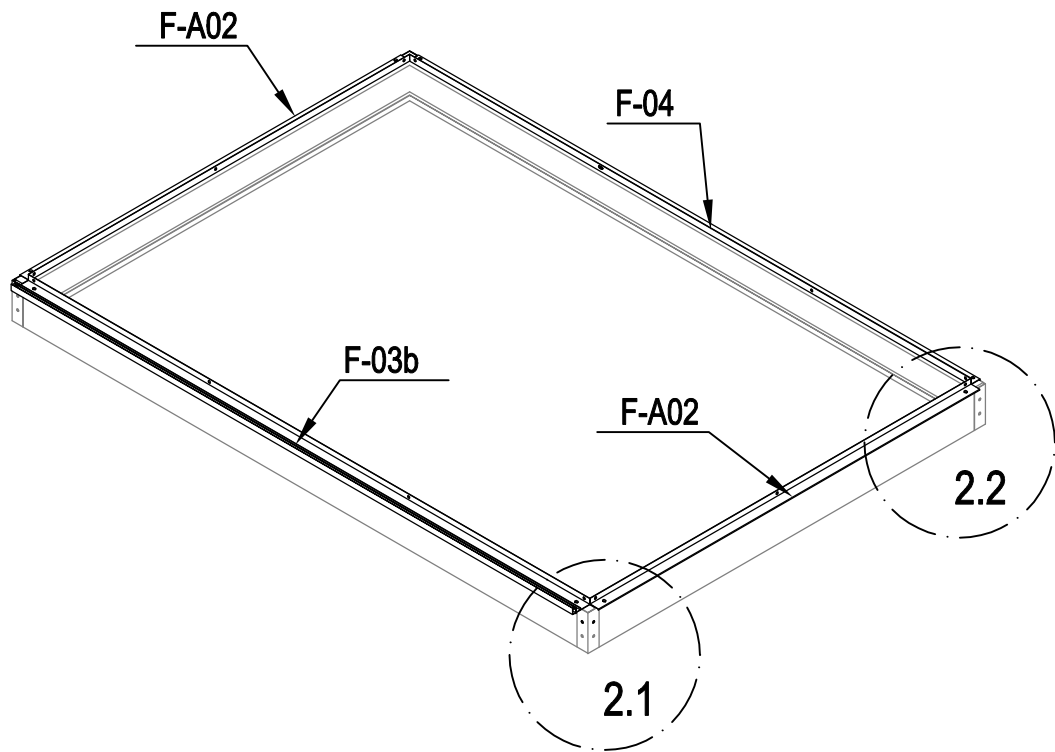



	F-A01	2
	F-02	2
	F-01	4
	F-A14	16



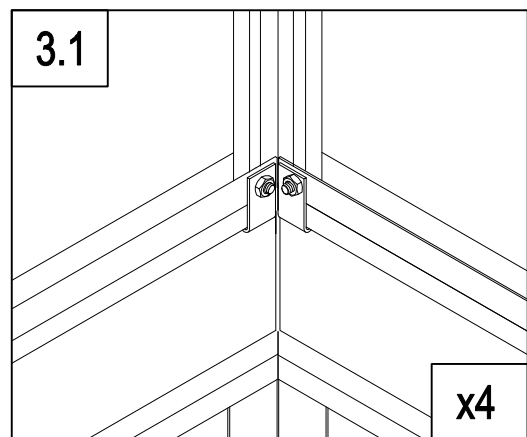
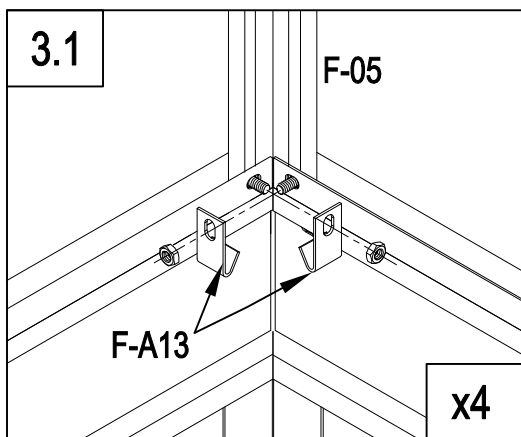
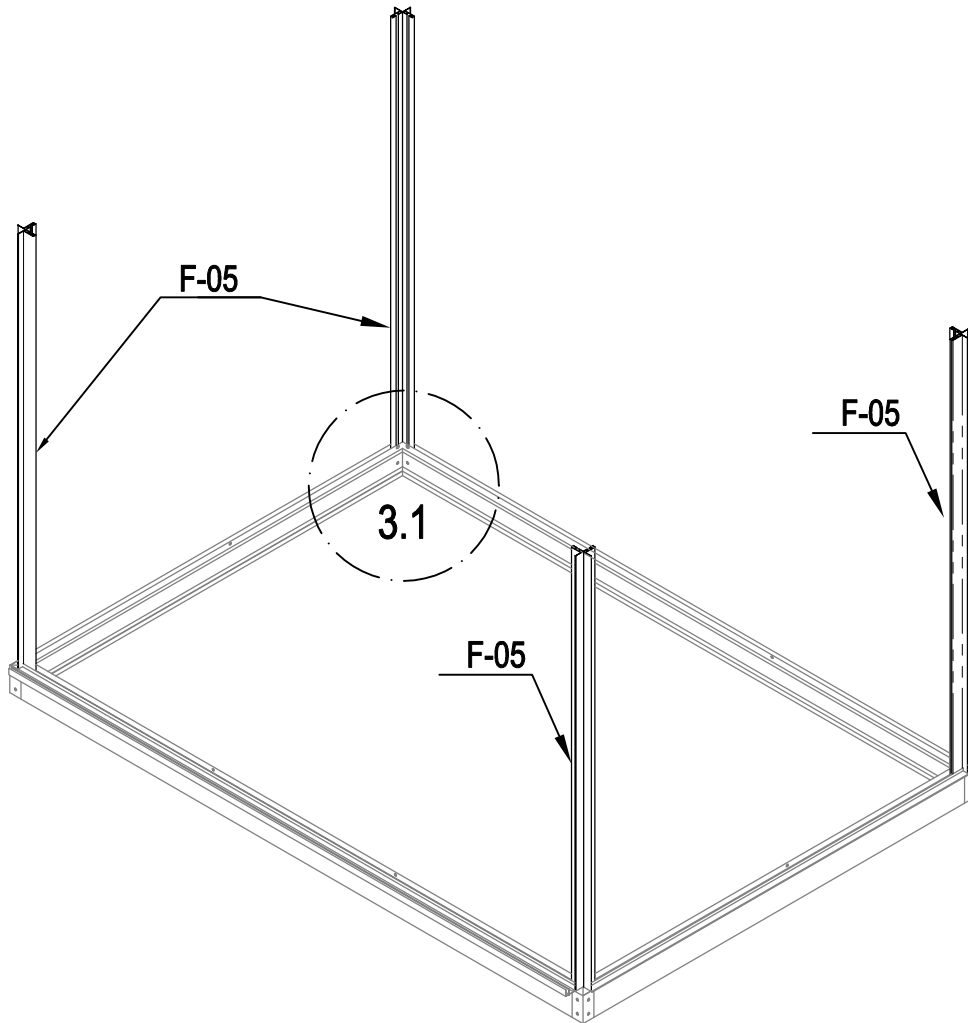

	F-A02	2
	F-04	1
	F-03b	1
	F-A14	8



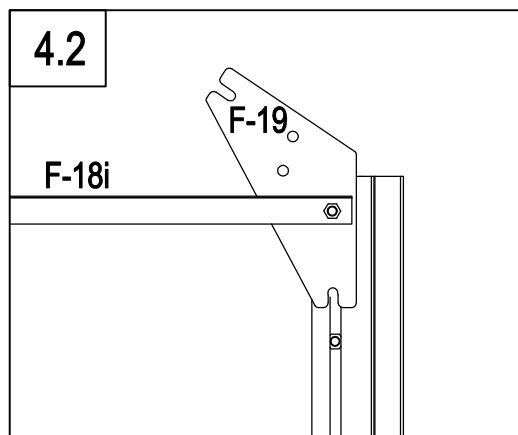
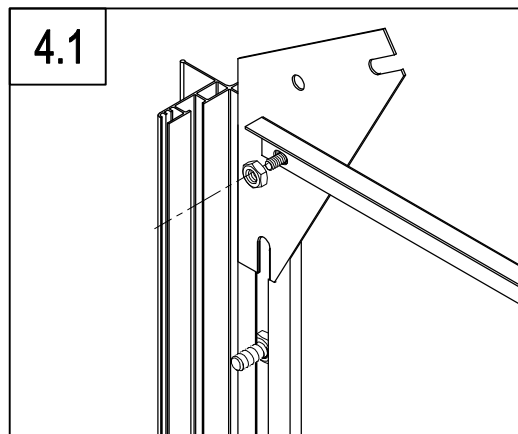
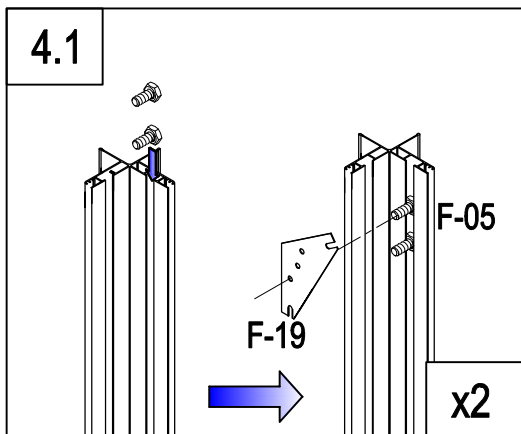
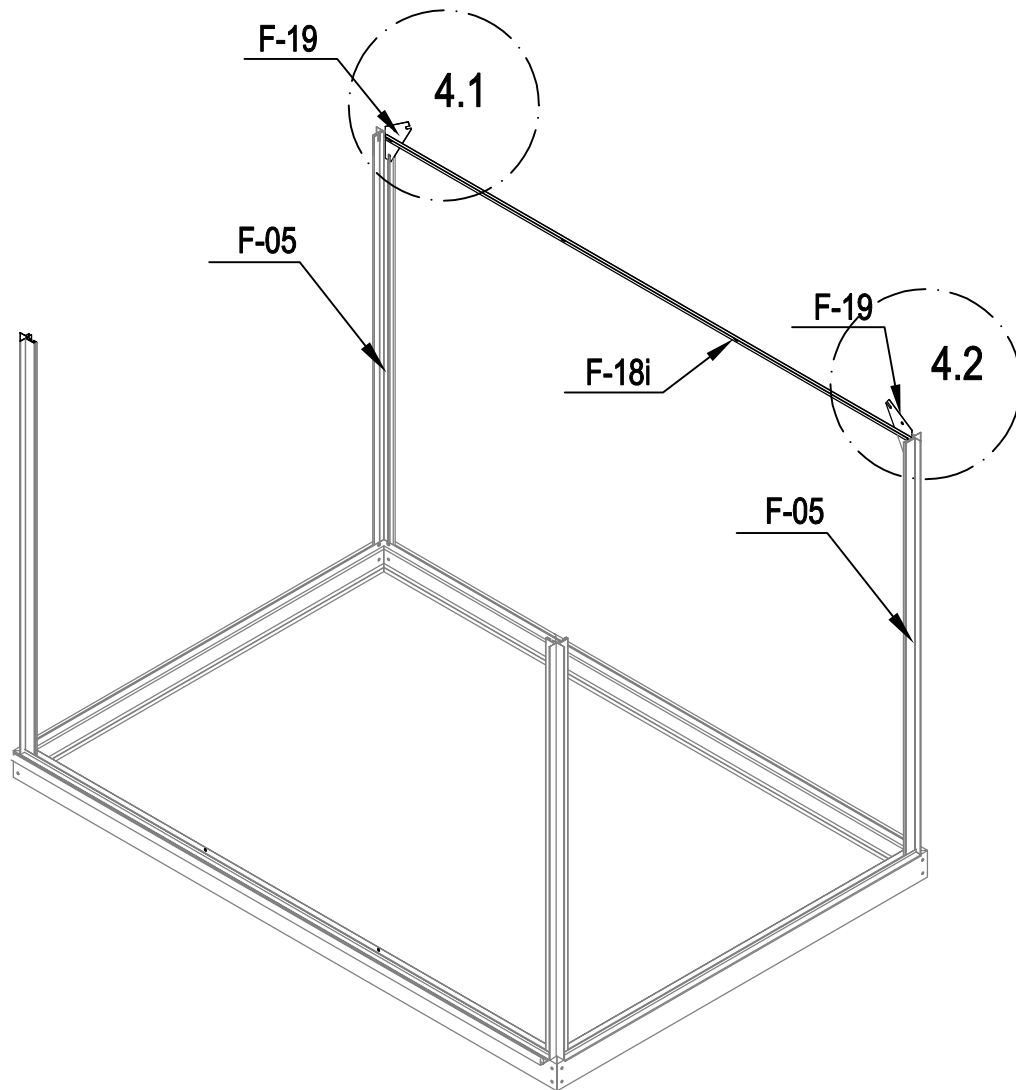

	F-05	4
	F-A13	8
	F-A14	8

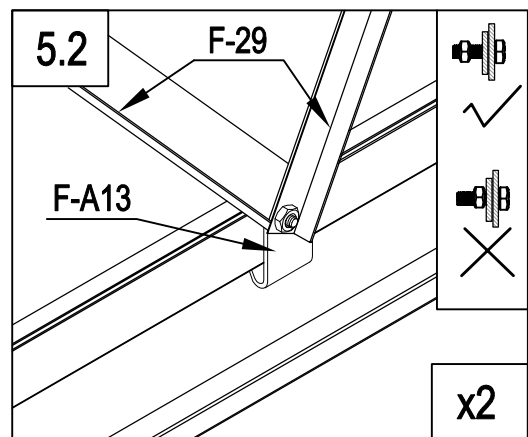
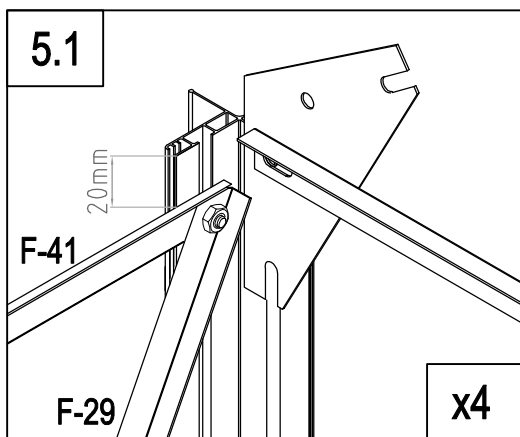
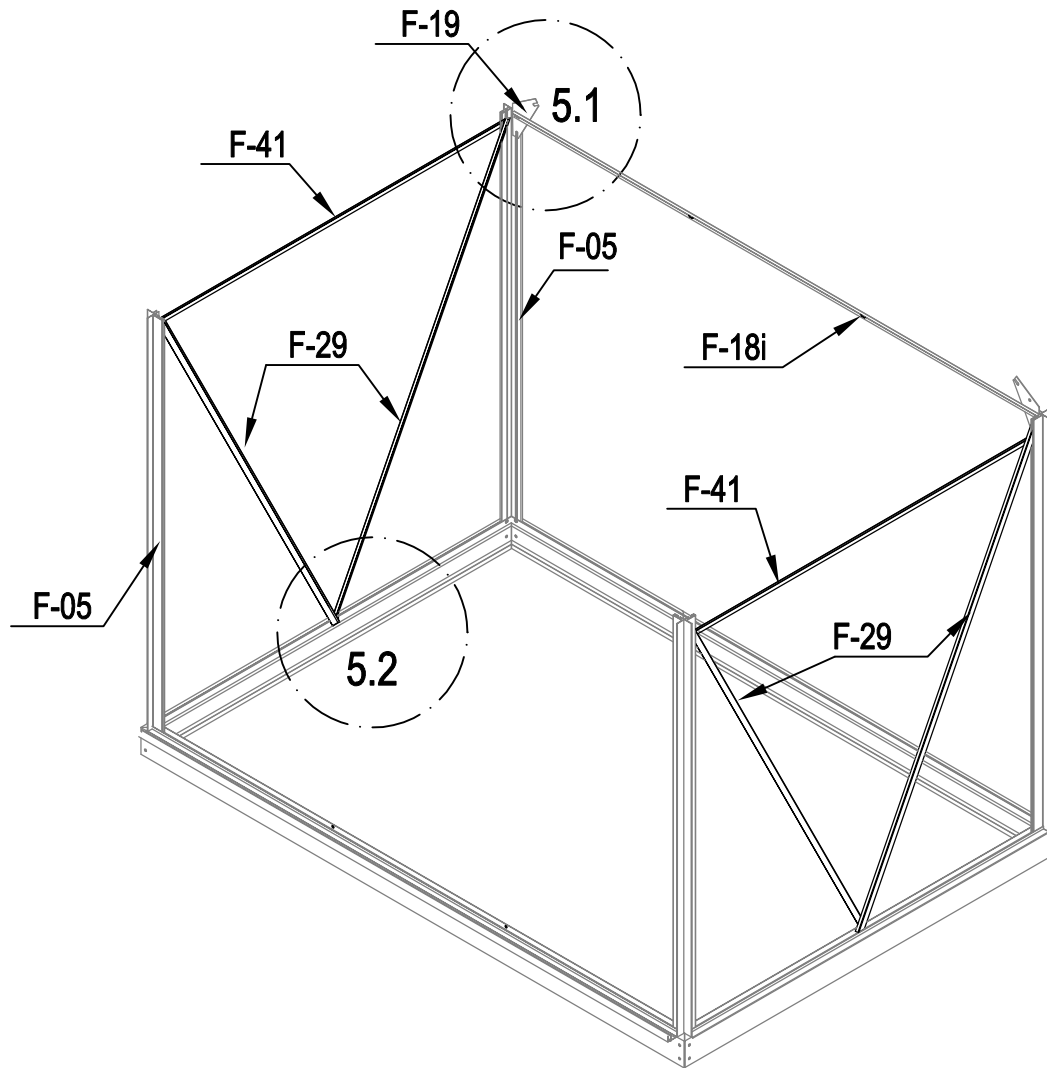

	F-18i	1
	F-19	2
	F-A14	4

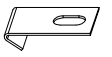
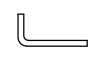



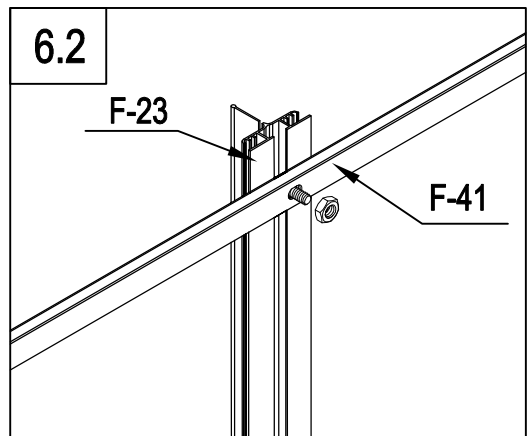
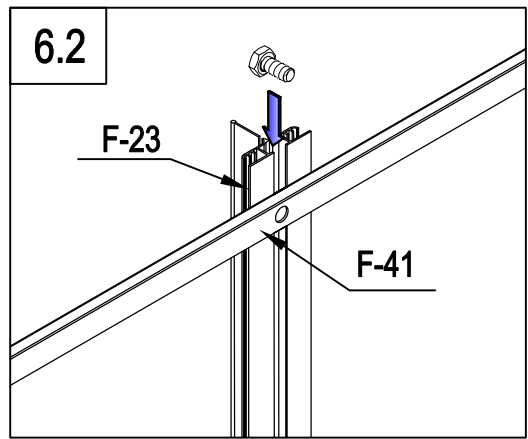
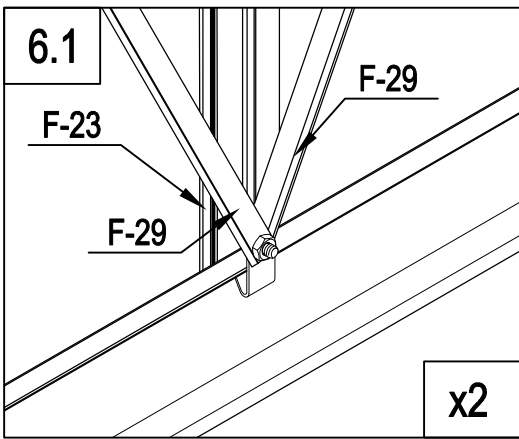
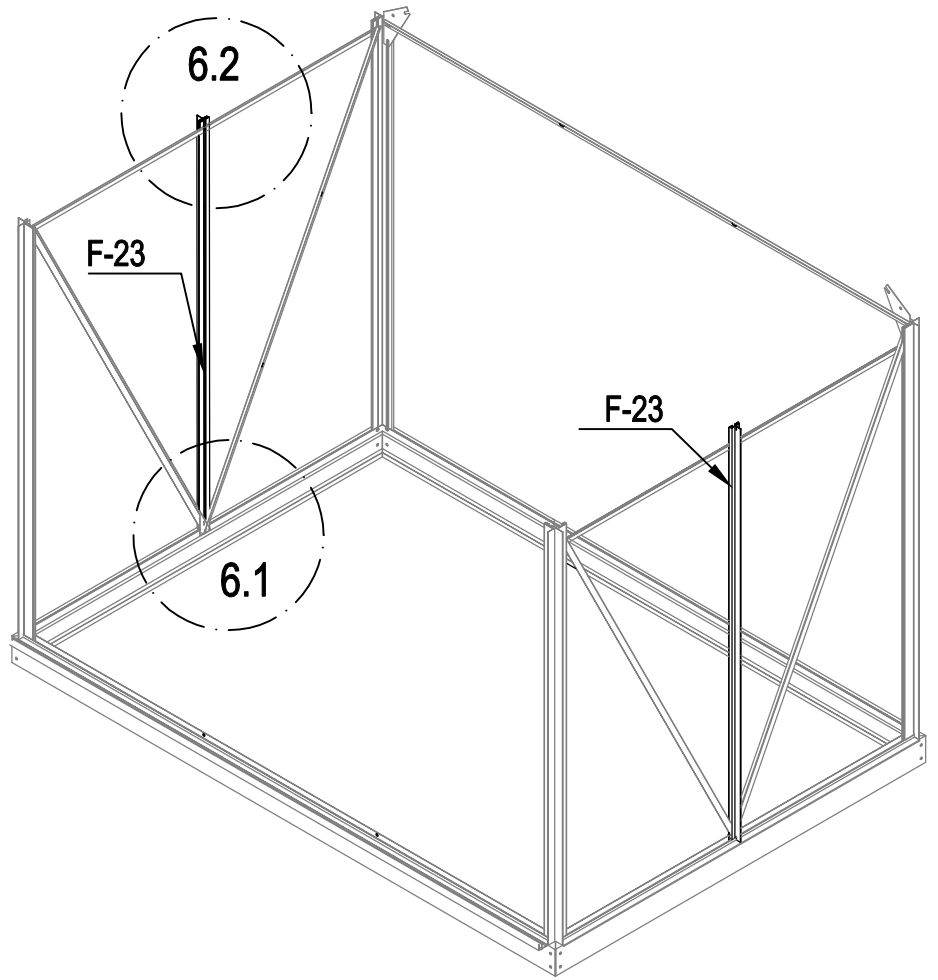
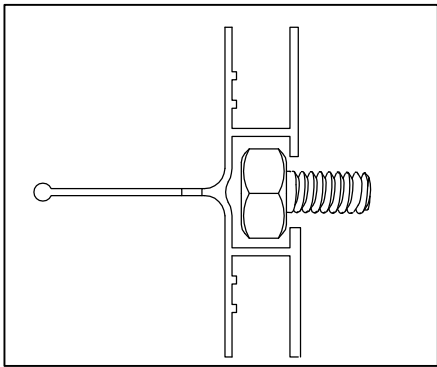
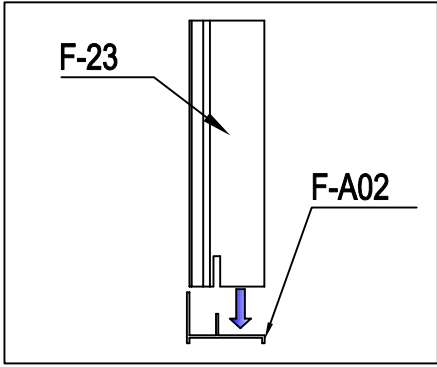

	F-A13	2
	F-29	4
	F-41	2
	F-A14	6

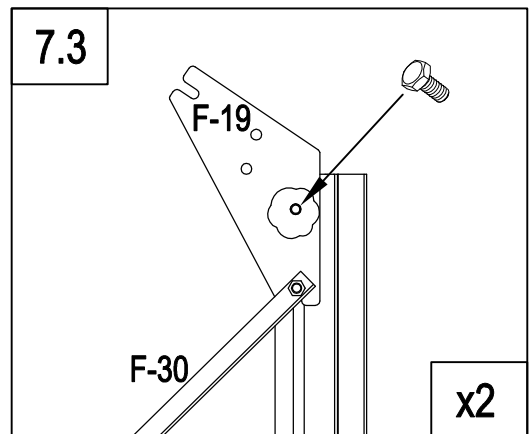
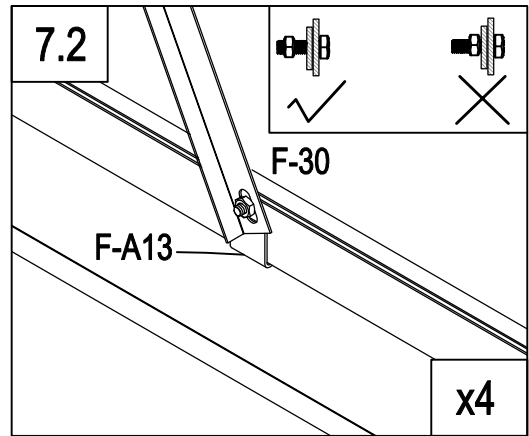
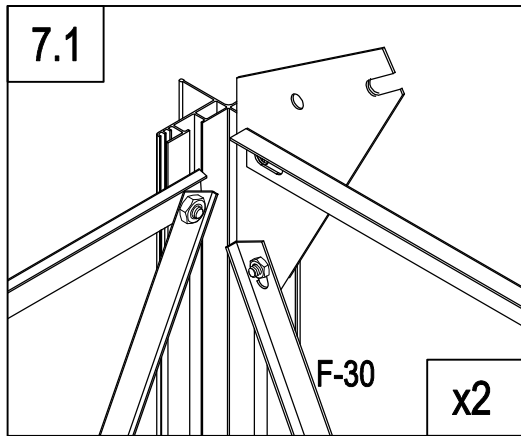
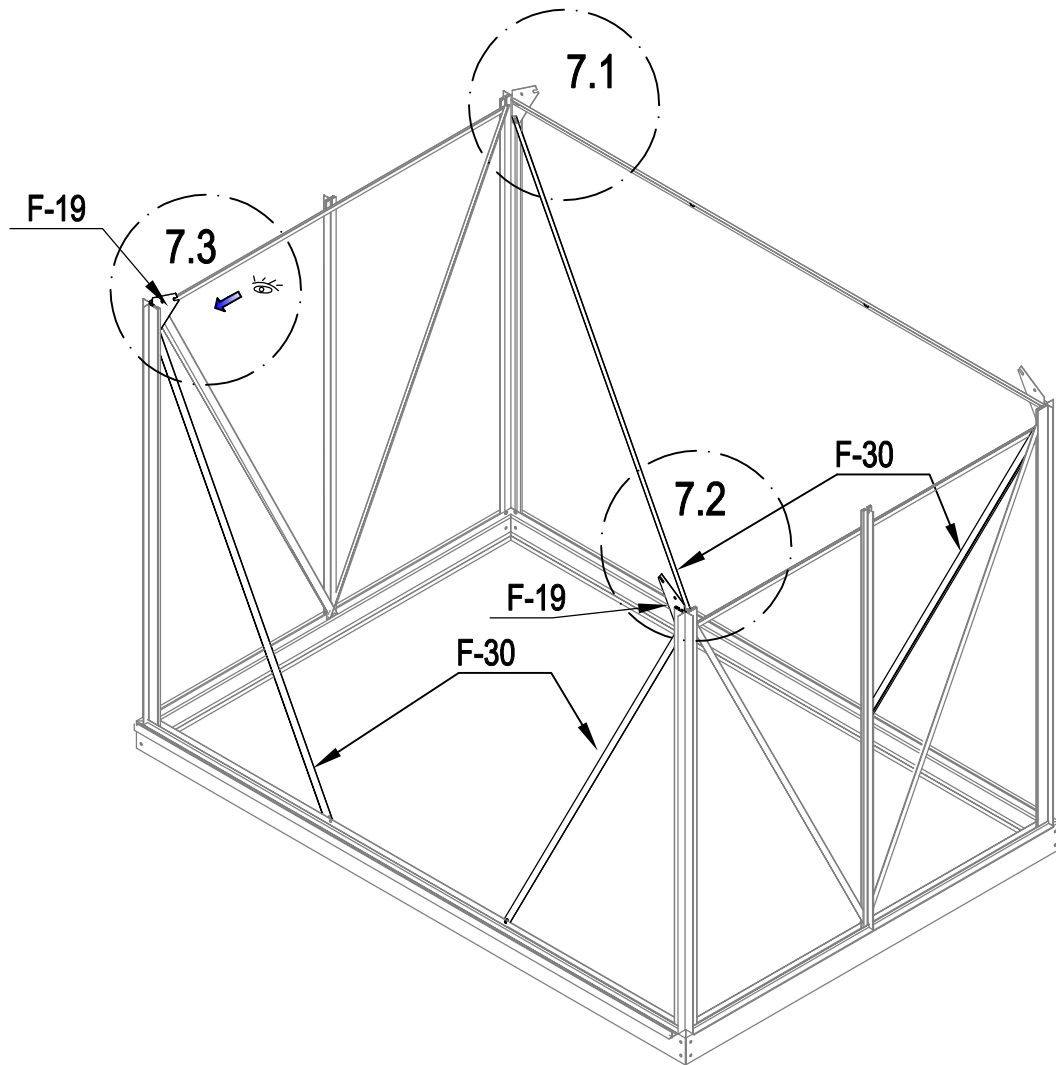

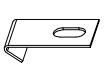
	F-23	2
	F-A14	2

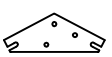

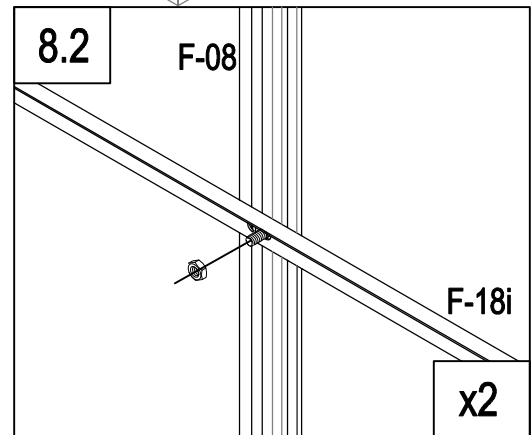
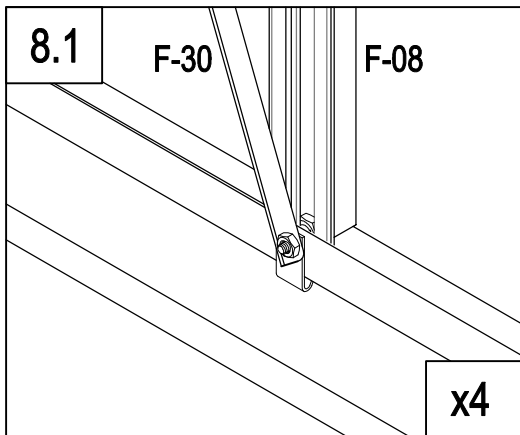
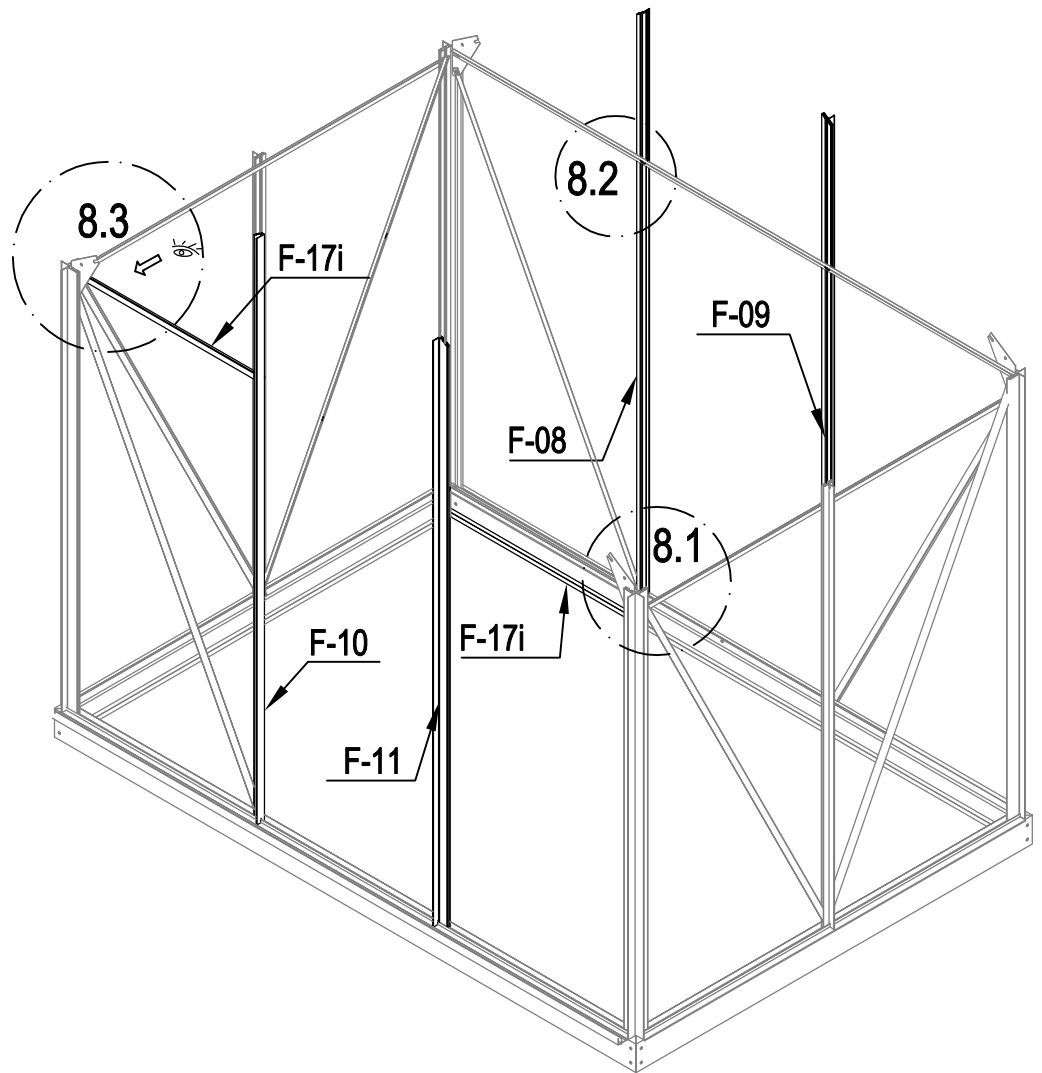

	F-A13	4
	F-30	4
	F-19	2
	F-A14	8

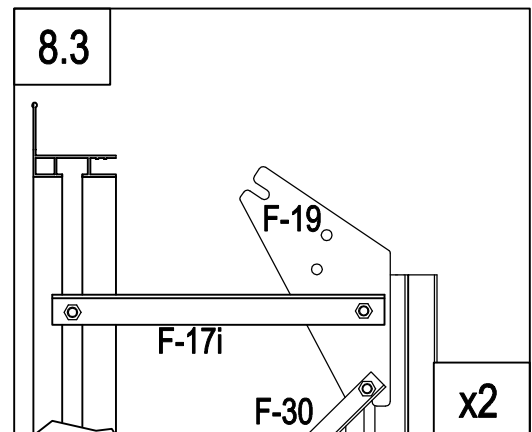

	F-08	1
	F-09	1
	F-10	1
	F-11	1
	F-17i	2
	F-A14	4

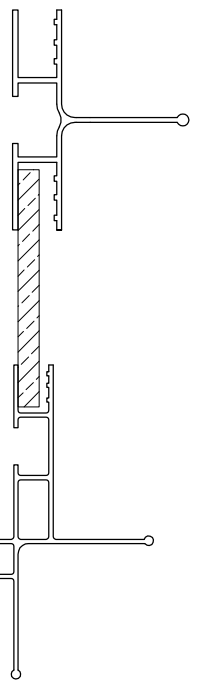
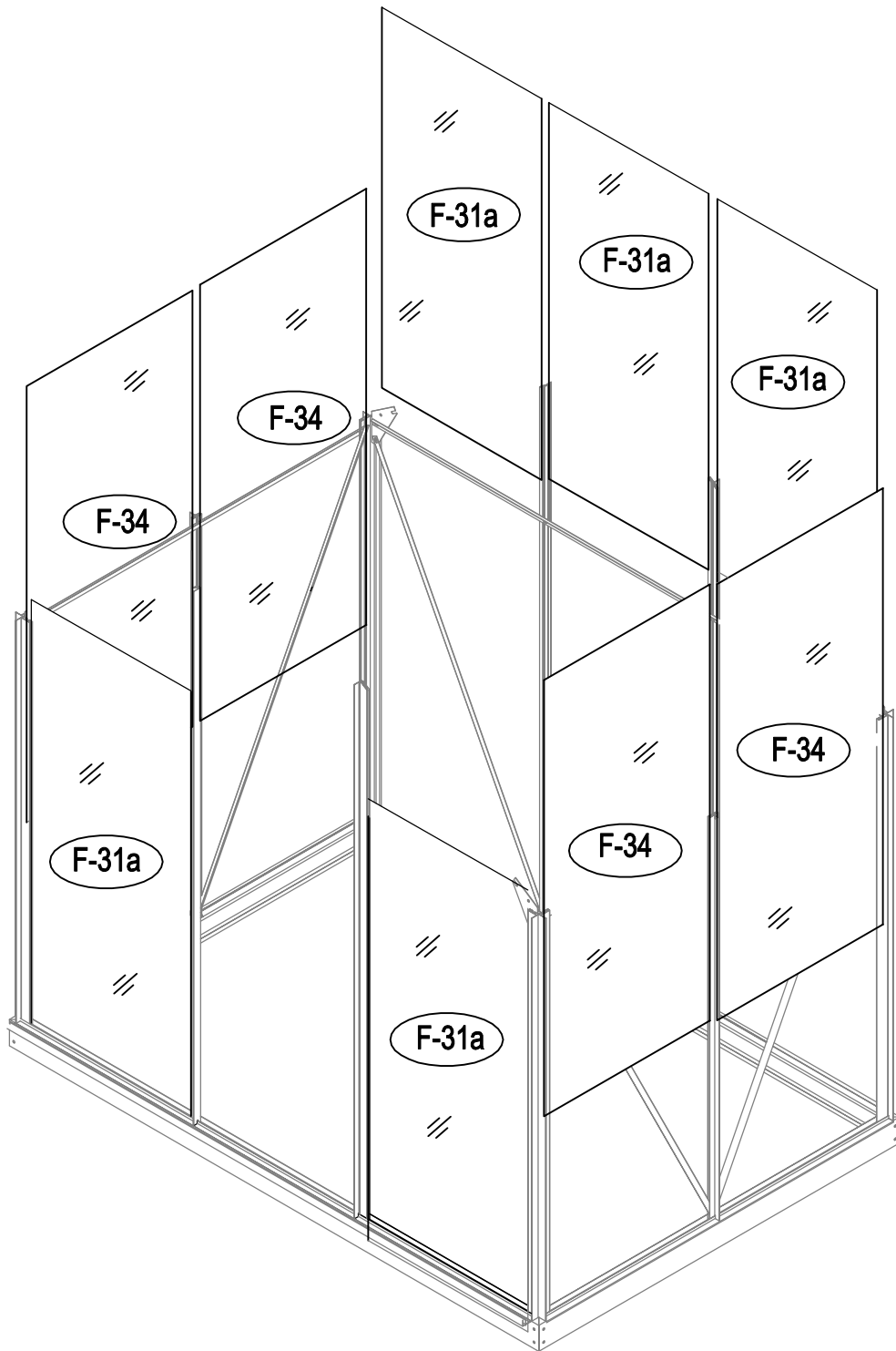







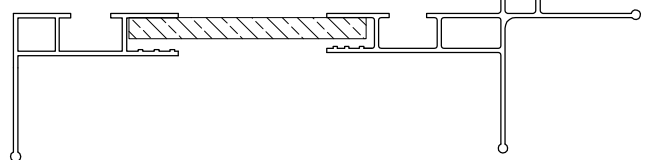

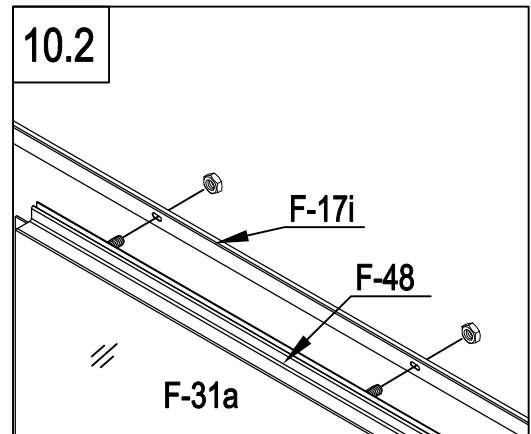
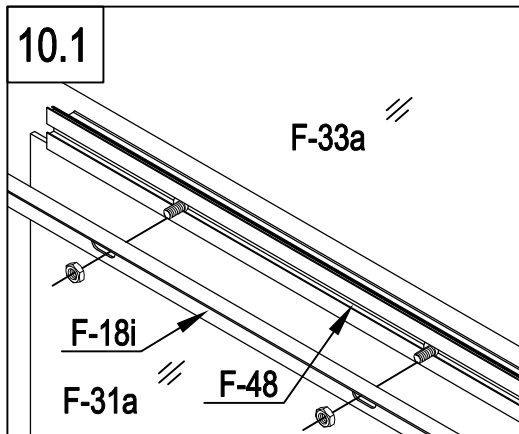
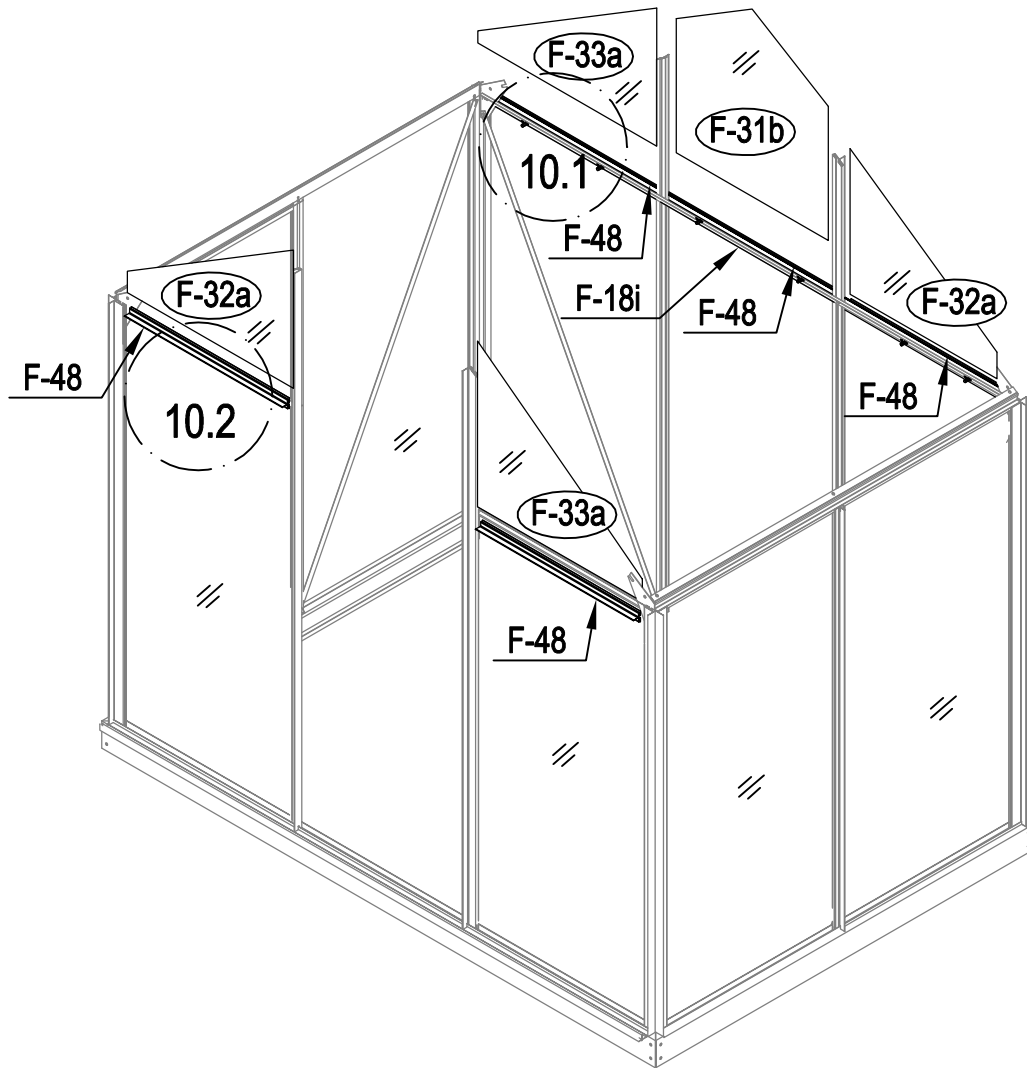
	F-31a	5
	F-34	4

9





	F-31b	1
	F-32a	2
	F-33a	2
	F-48	5
	F-A14	10

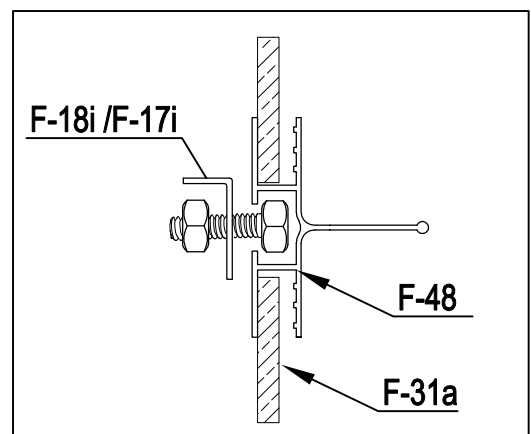

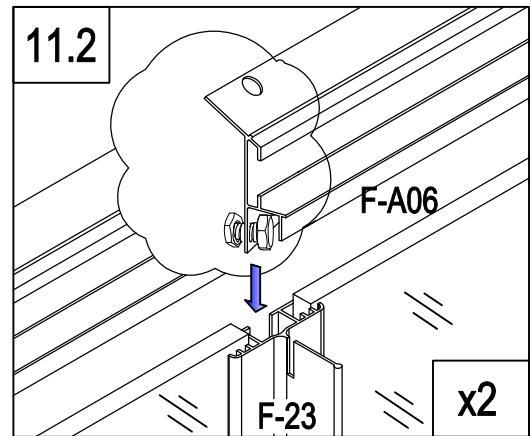
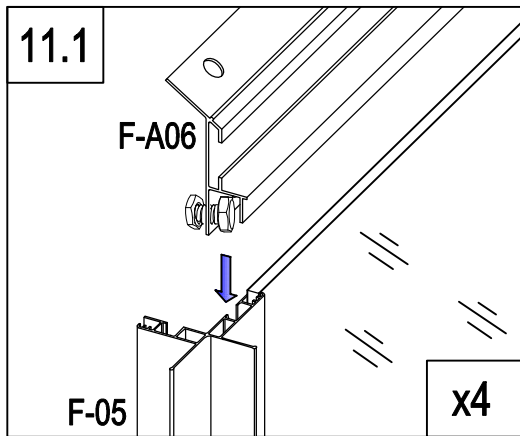
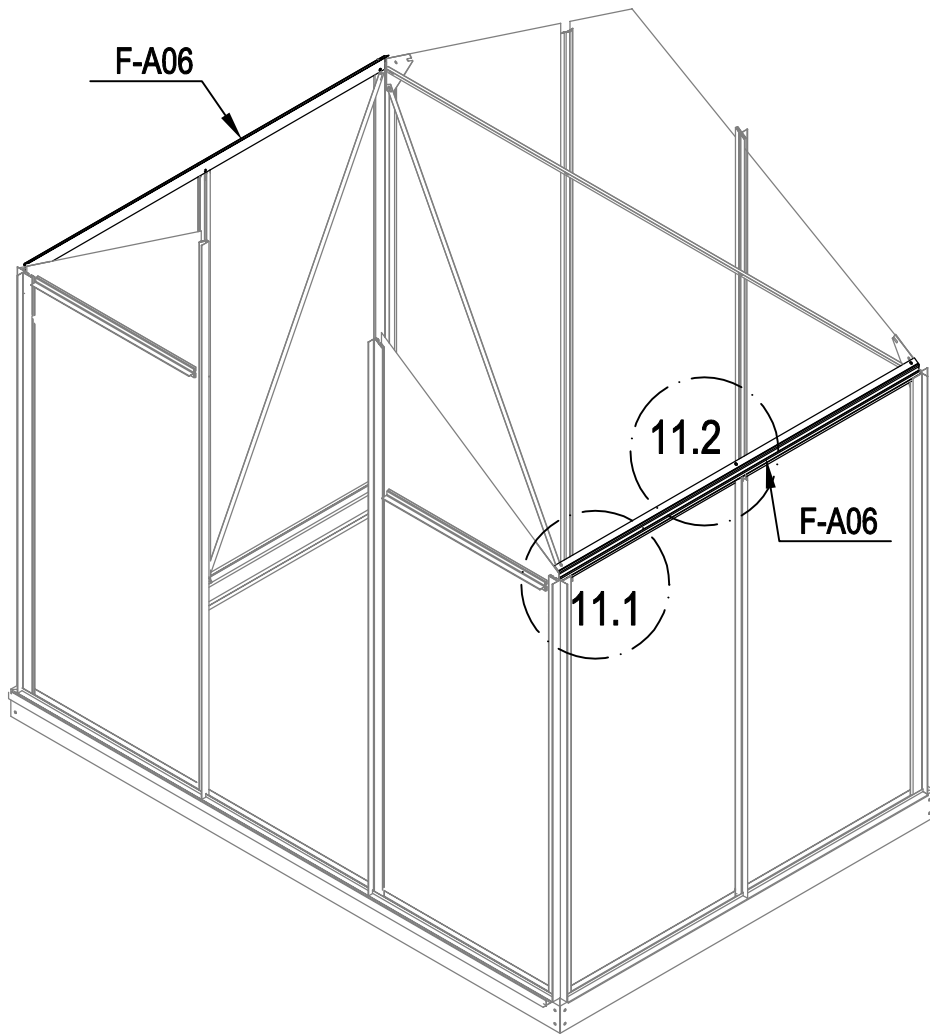

	F-A06	2
	F-A14	6

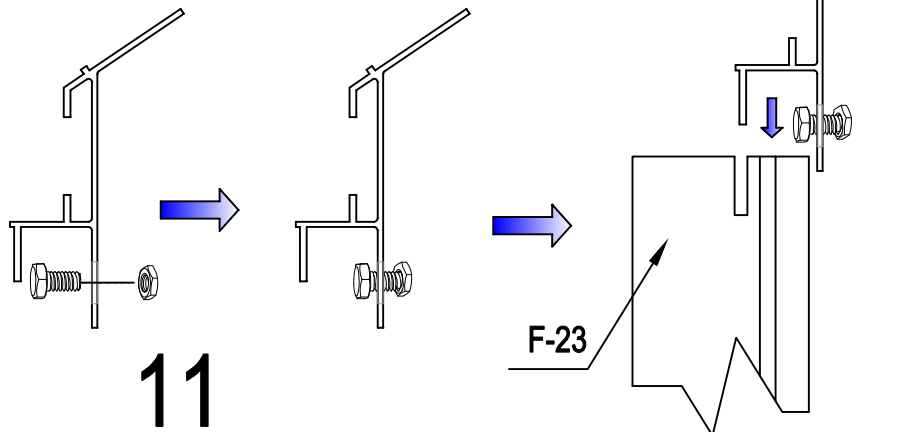

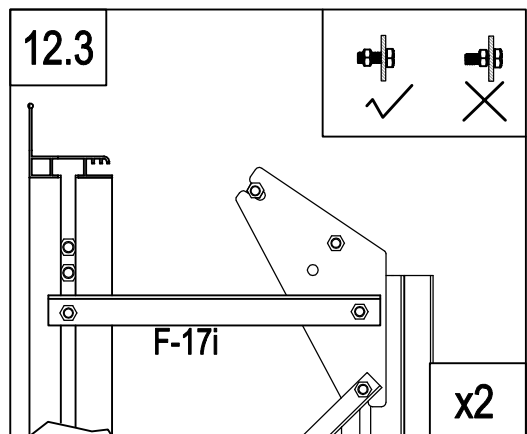
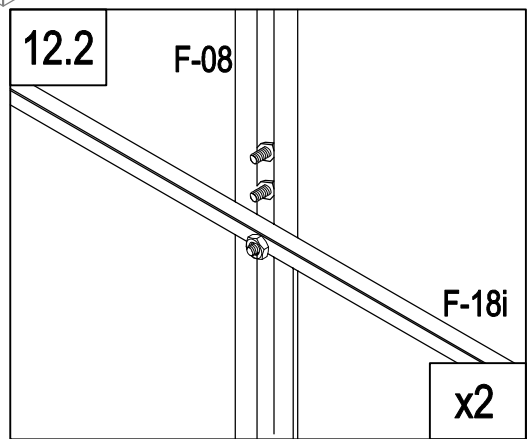
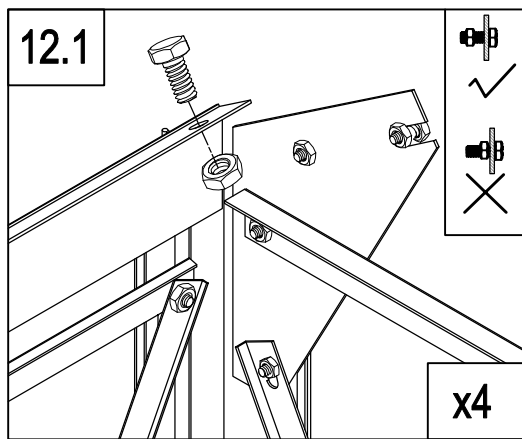
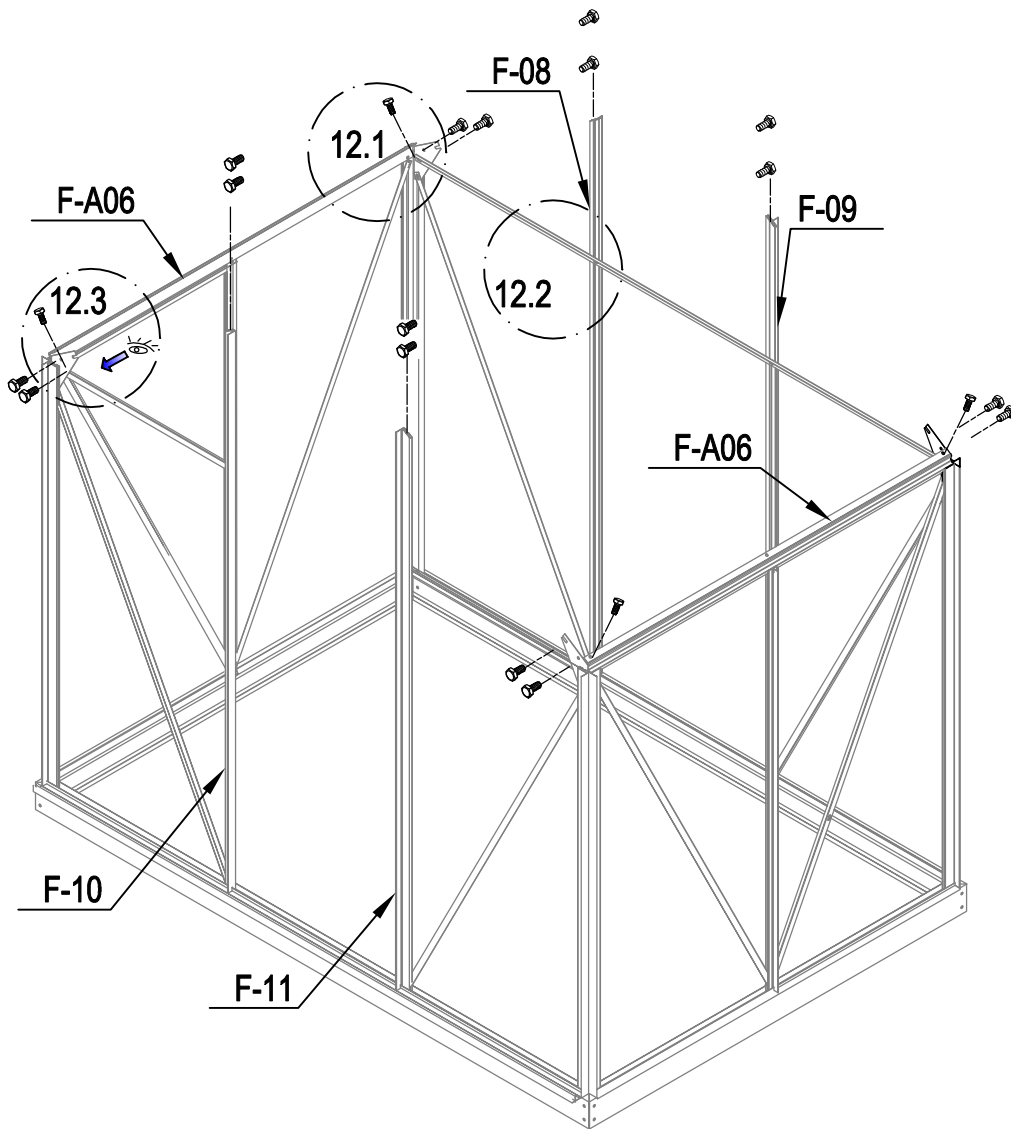

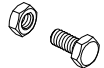
	F-A14	20
---	--------------	-----------

12

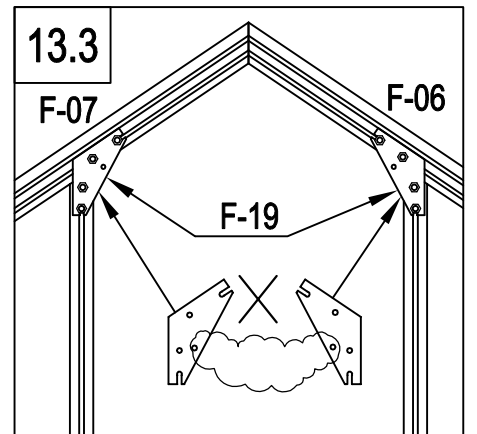
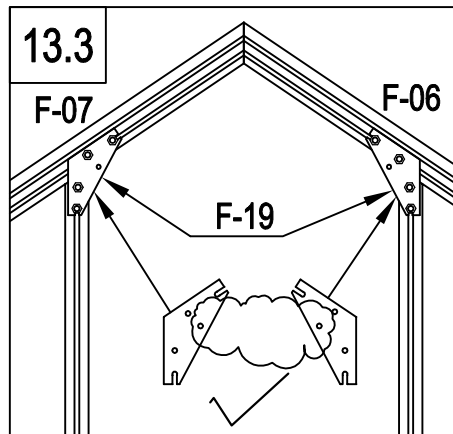
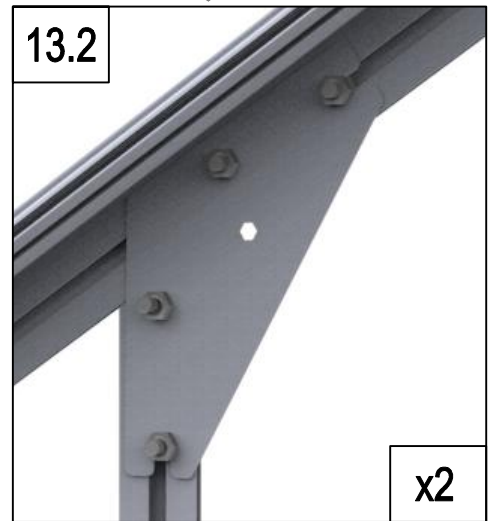
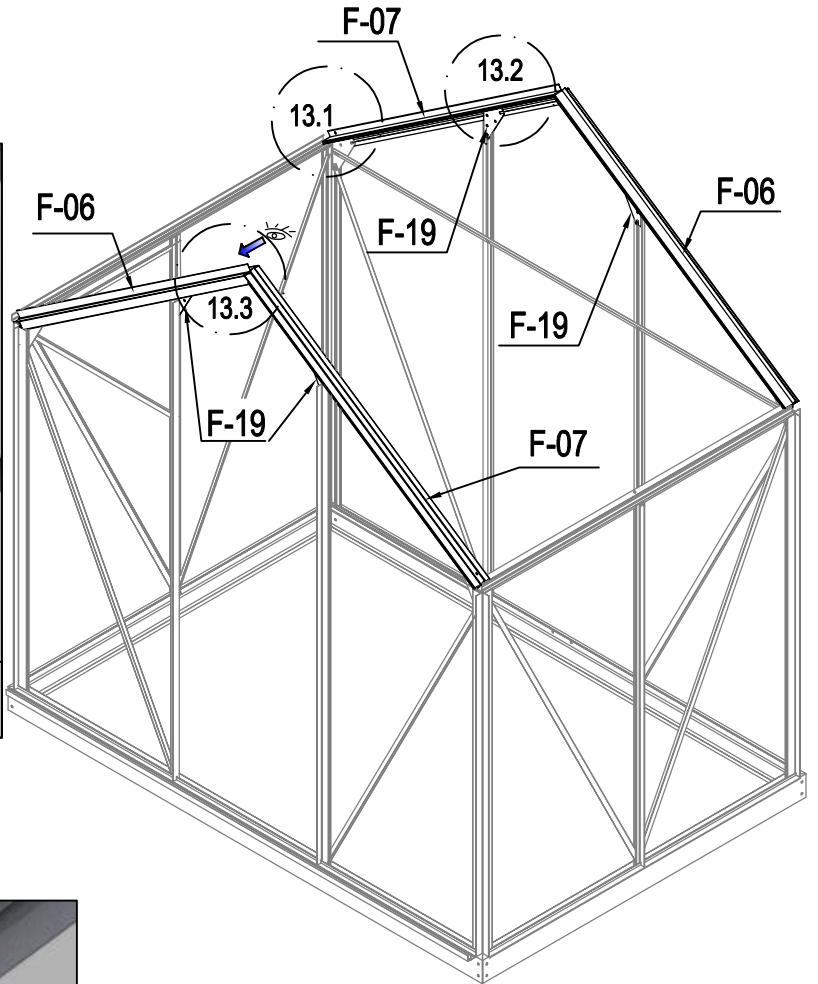
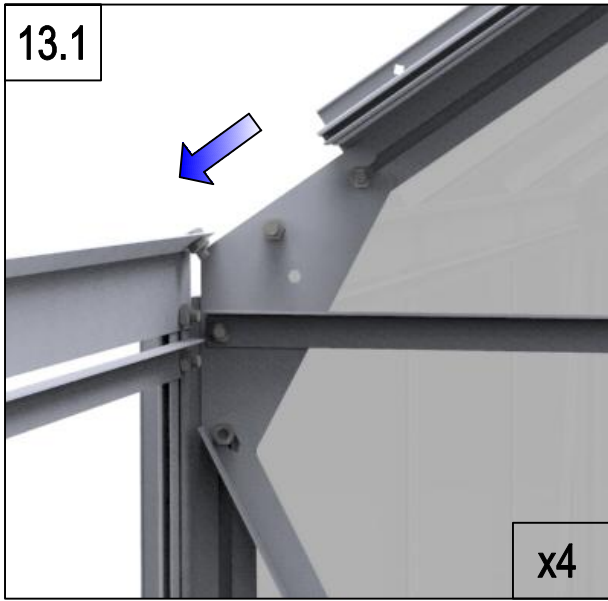



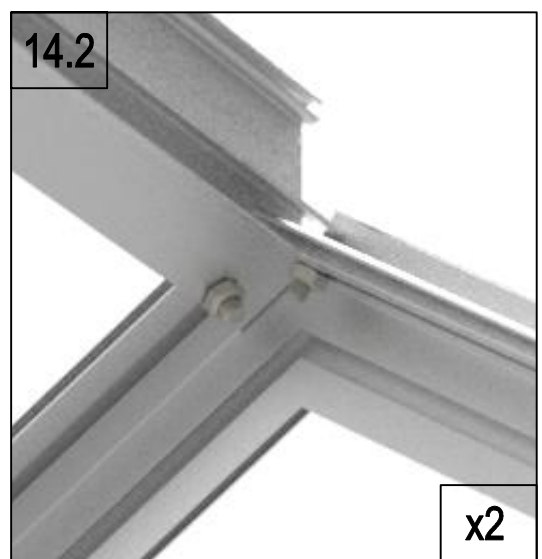
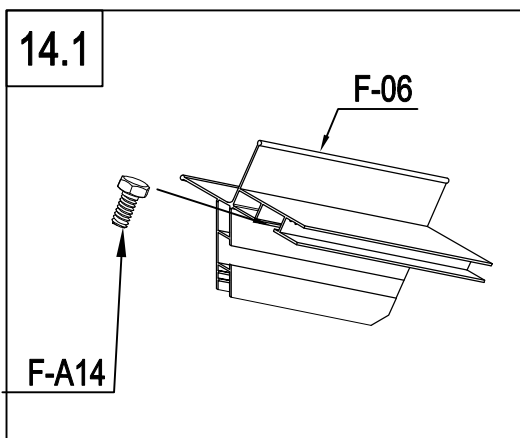
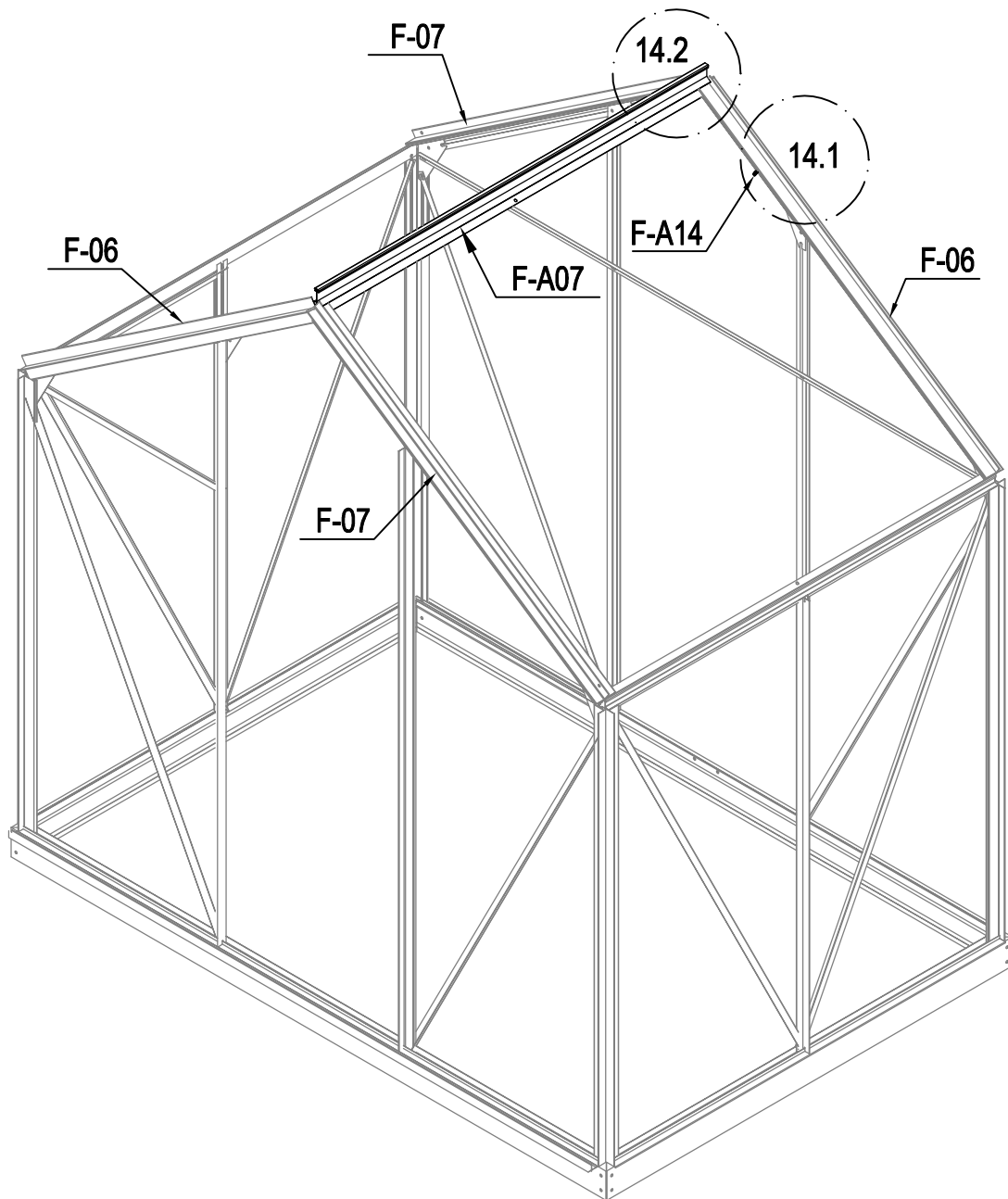

	F-06	2
	F-07	2
	F-19	4
	F-A14	8

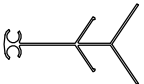
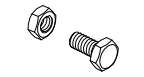
13

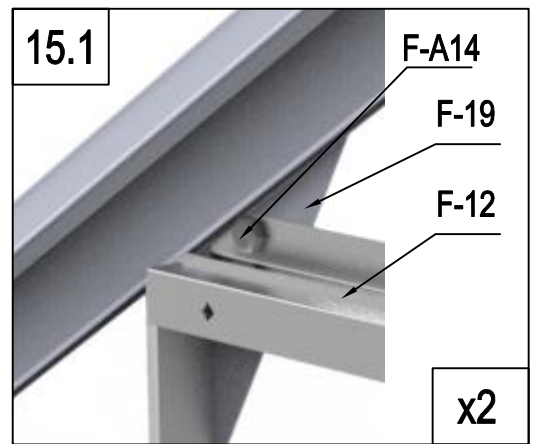
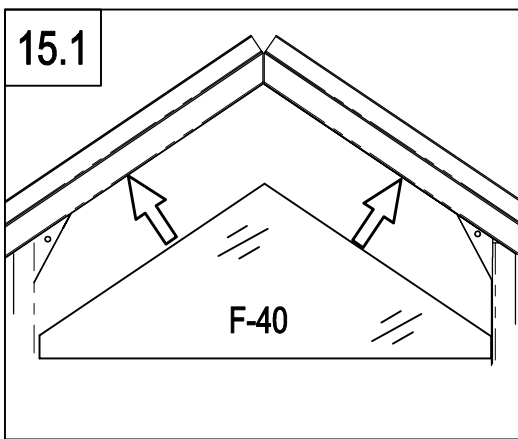
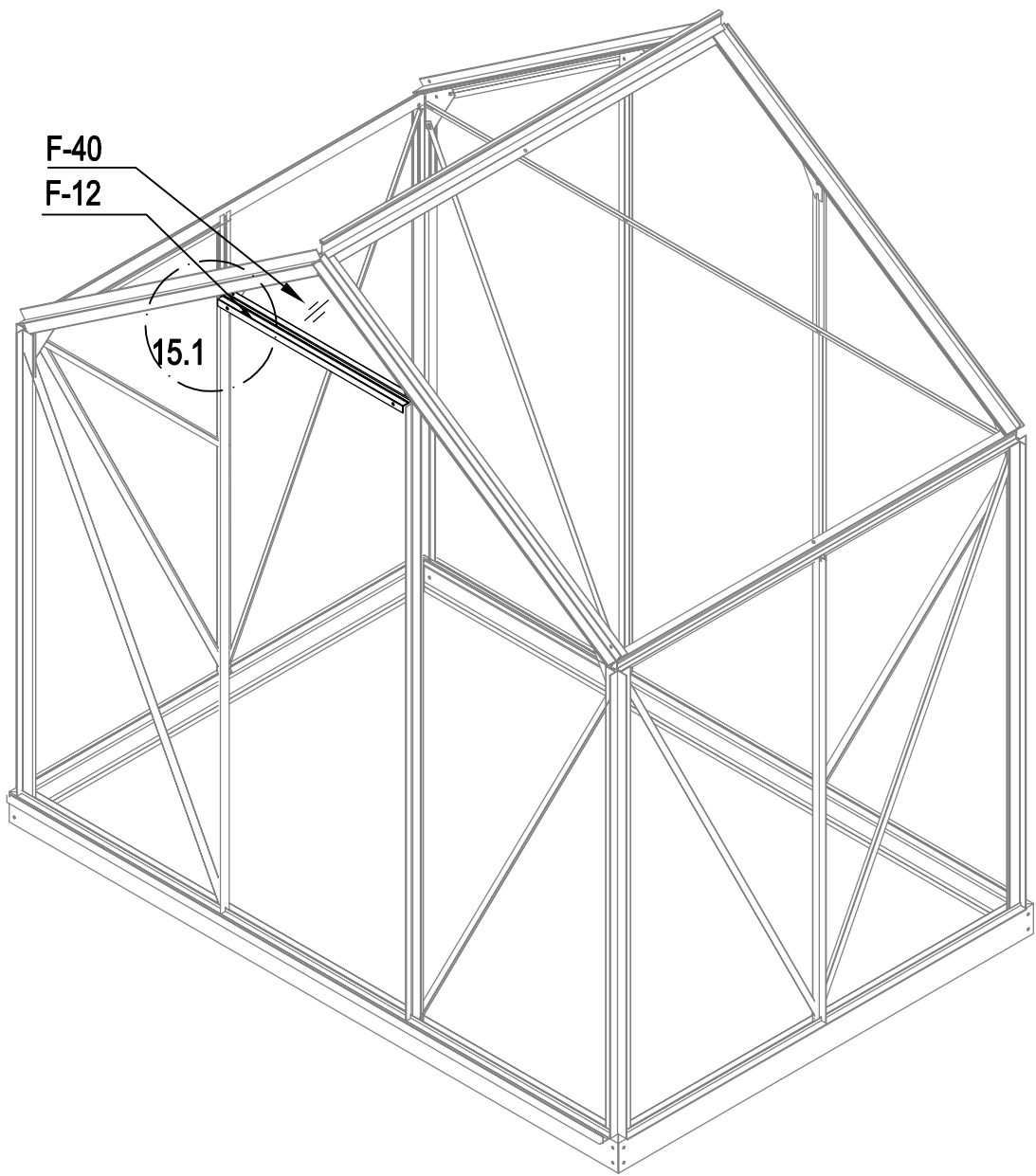

	F-A07	1
	F-A14	5



	F-12	1
	F-40	1
	F-A14	2

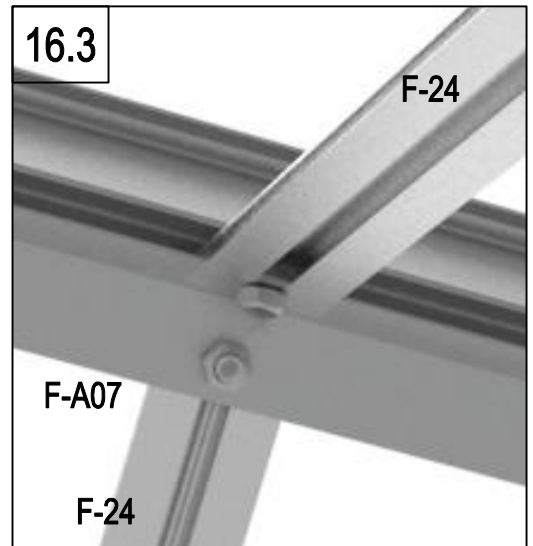
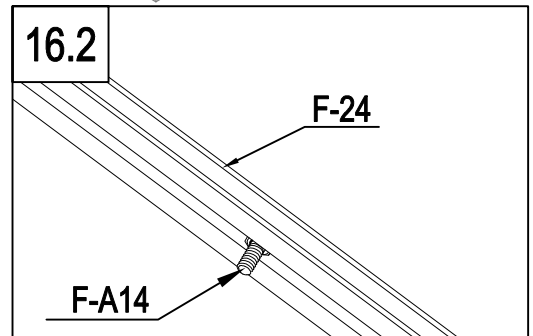
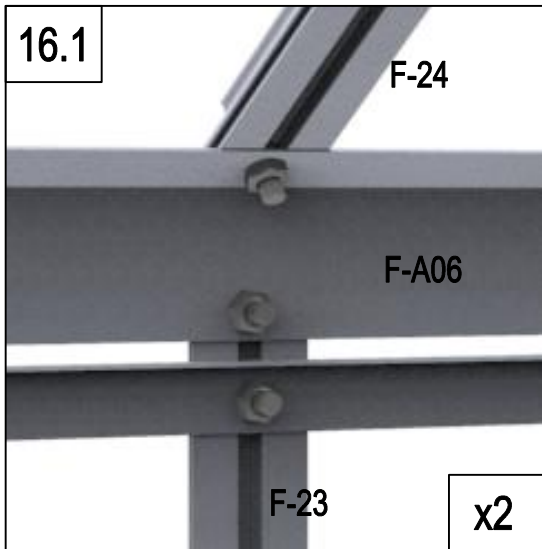
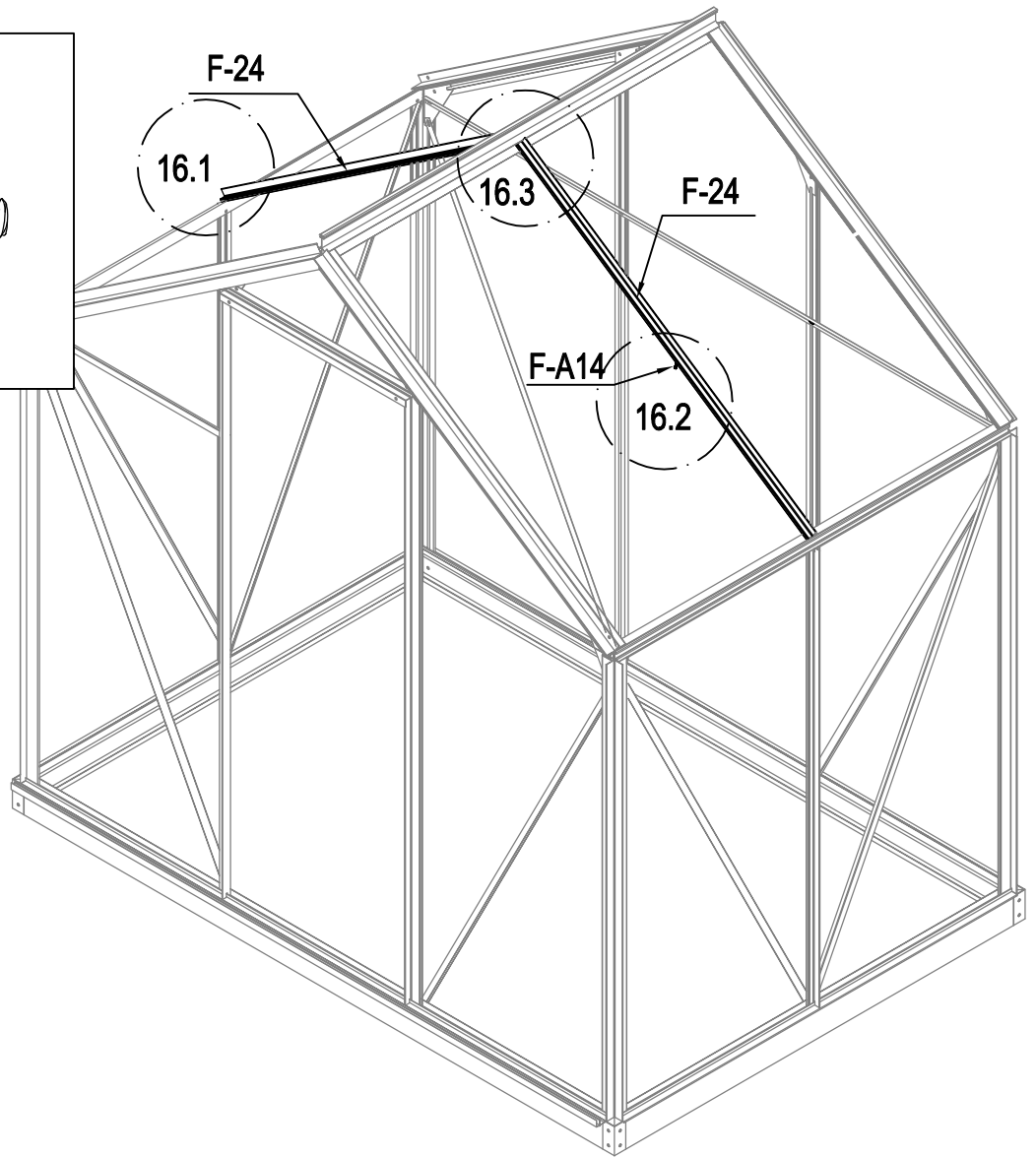
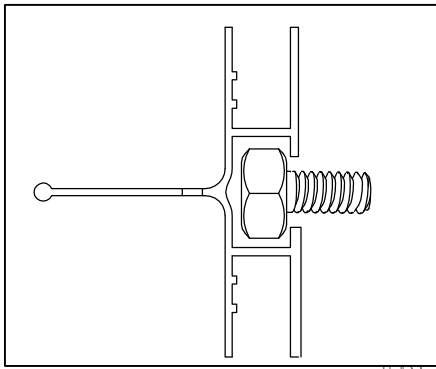

	F-24	2
	F-A14	5

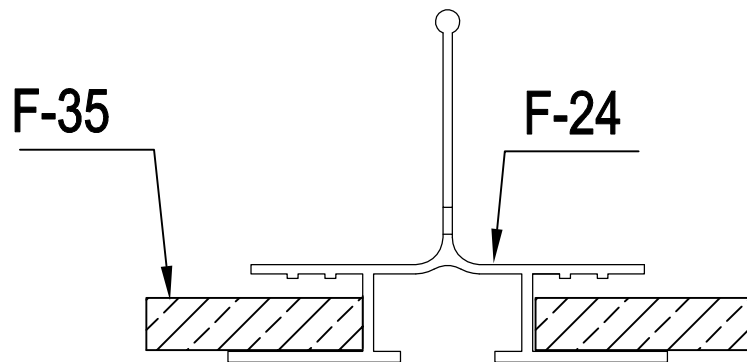
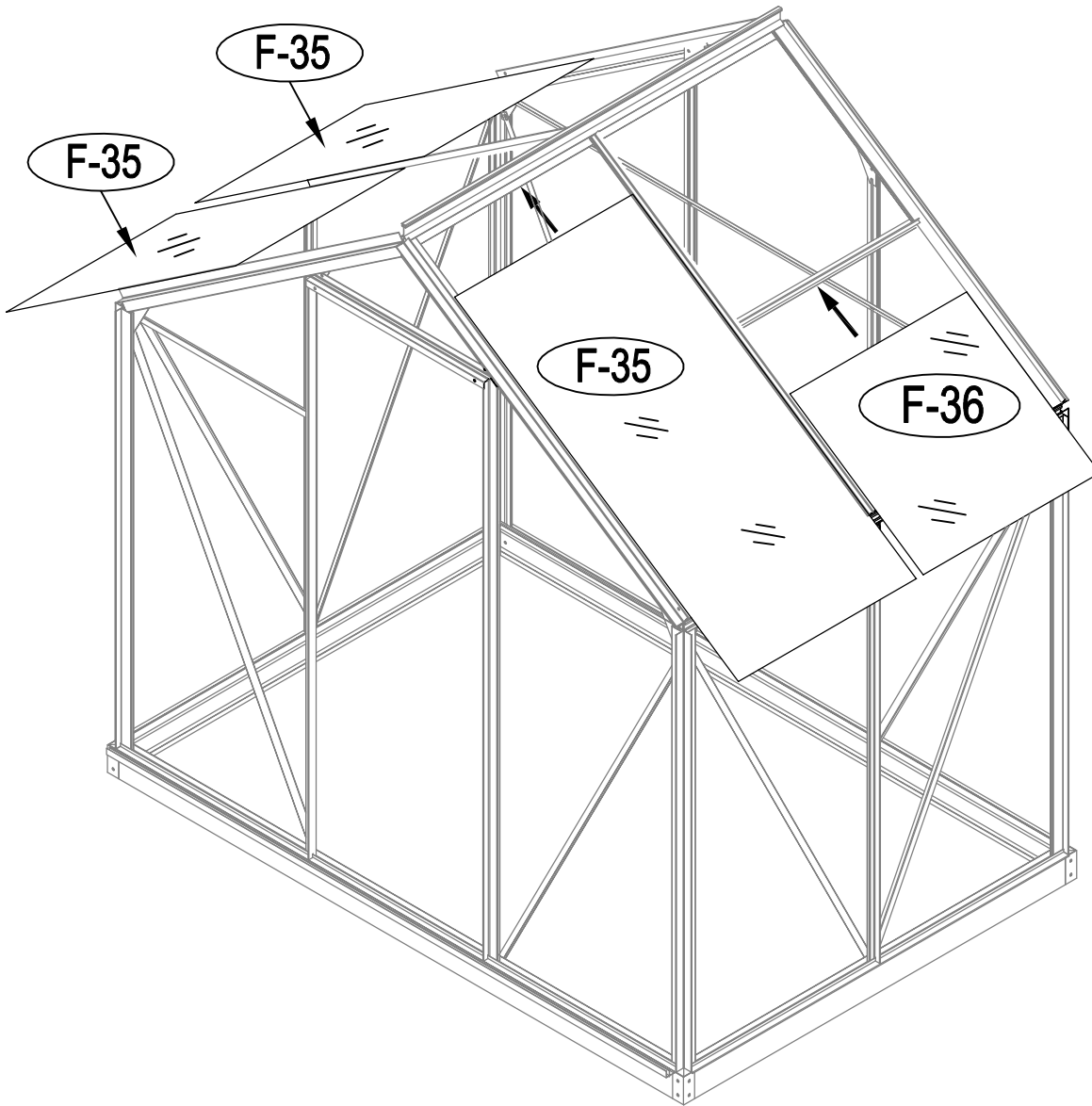

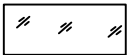
	F-36	1
	F-35	3

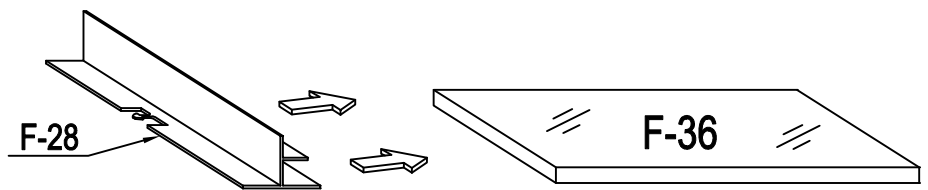
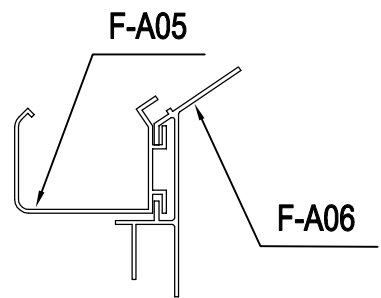
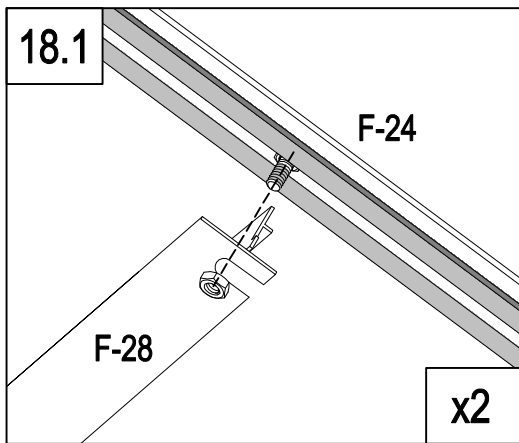
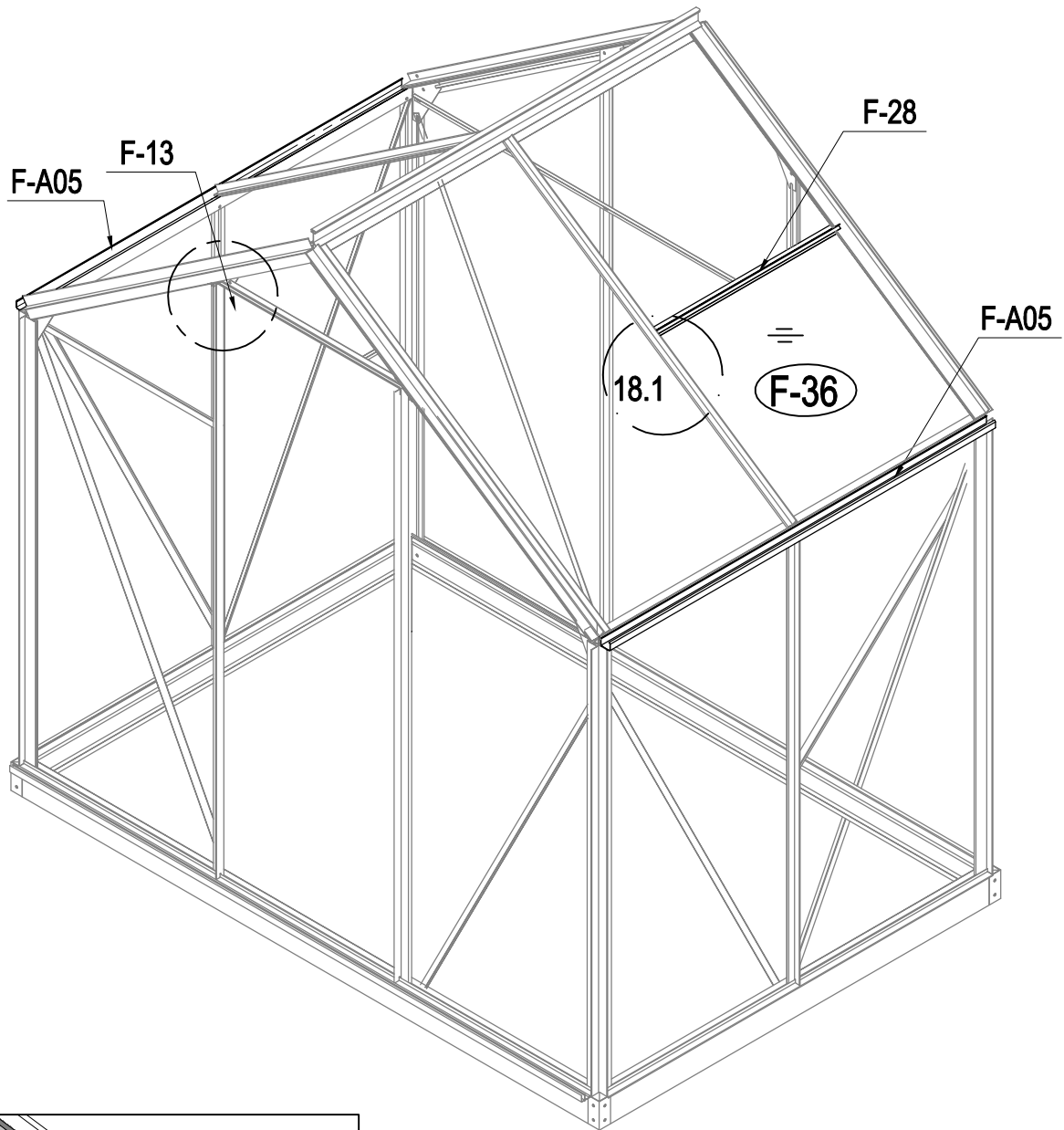

	F-A05	2
	F-28	1

18

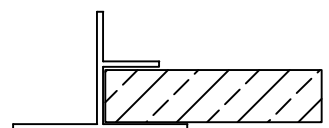

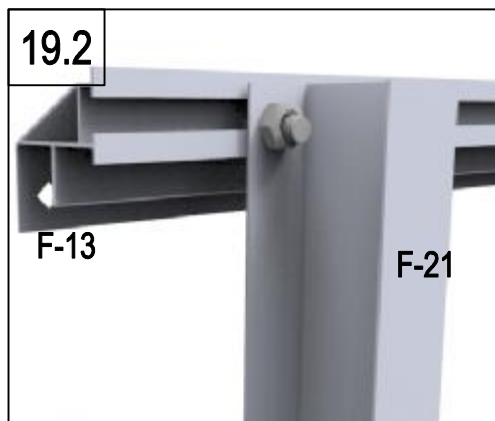
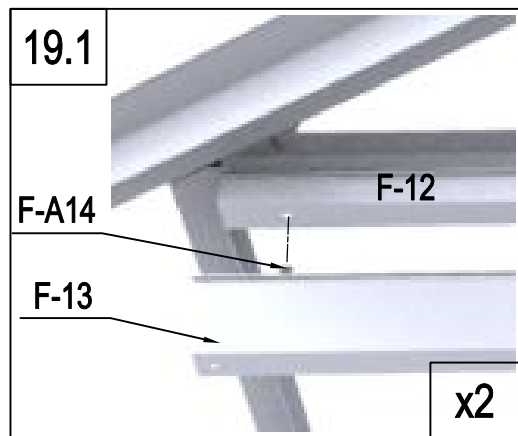
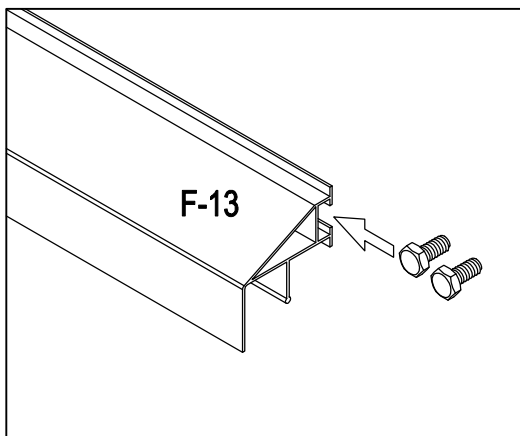
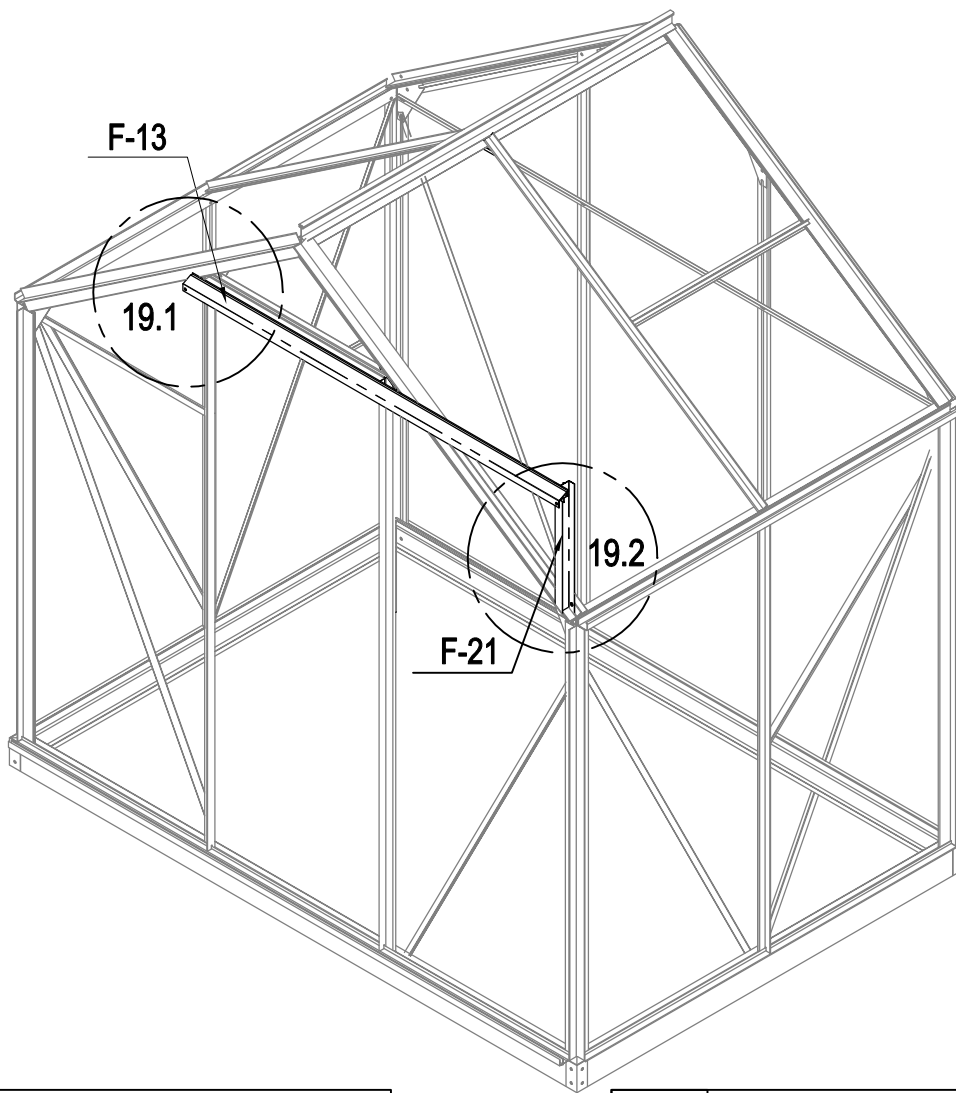



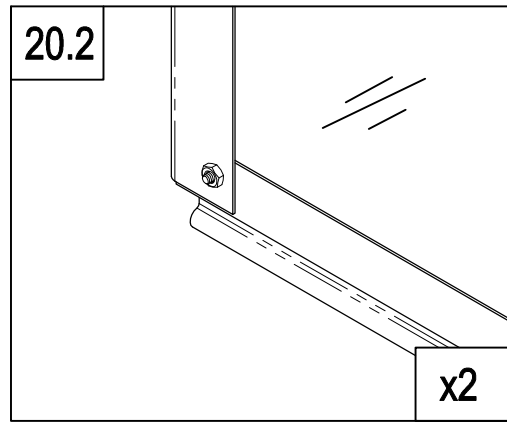
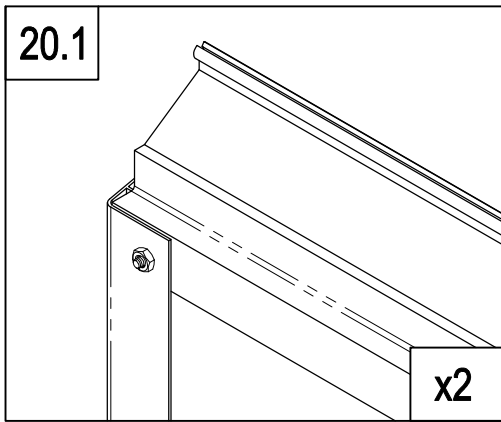
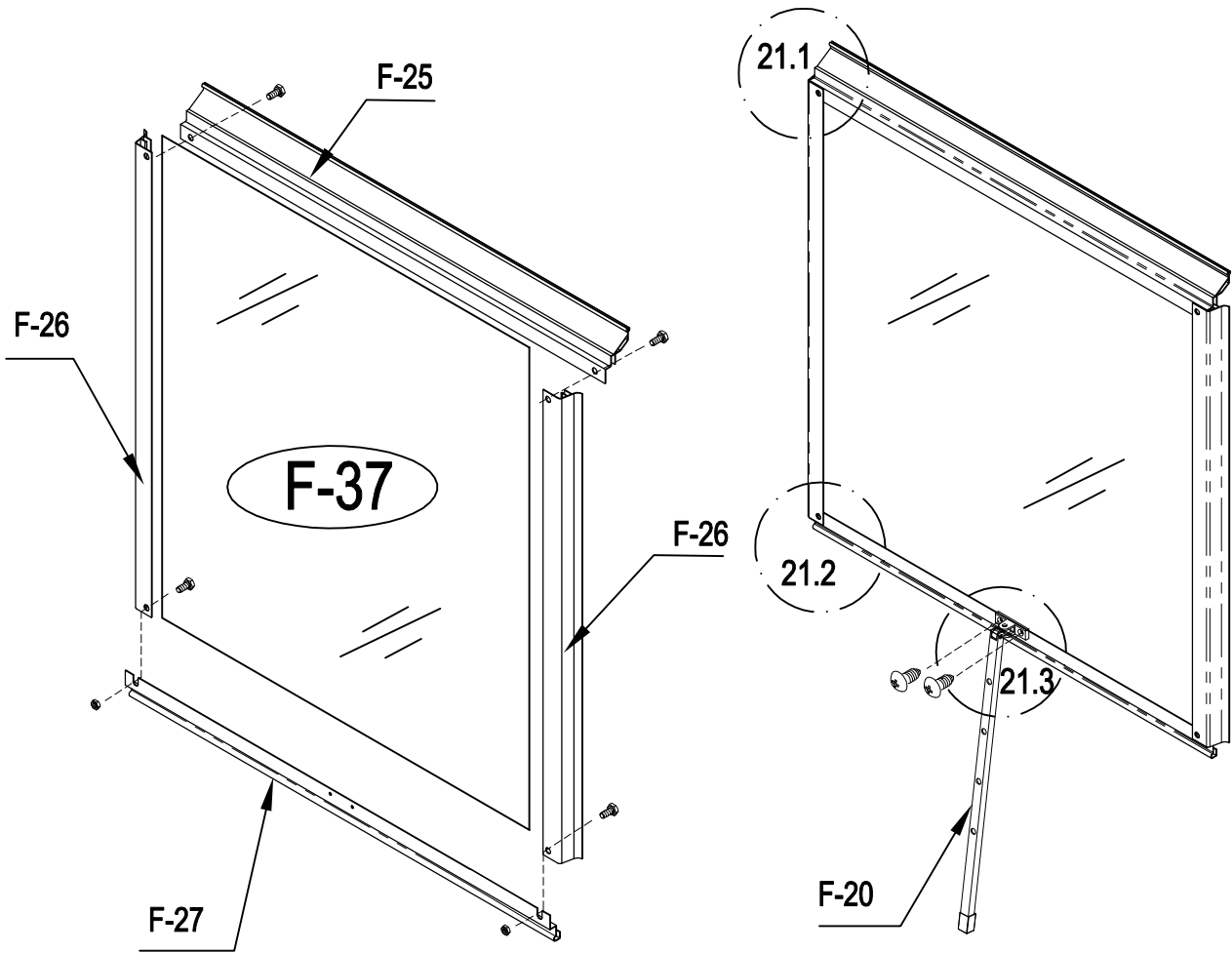

	F-13	1
	F-21	1
	F-A14	4

19

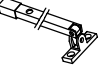
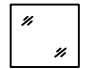

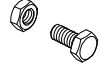

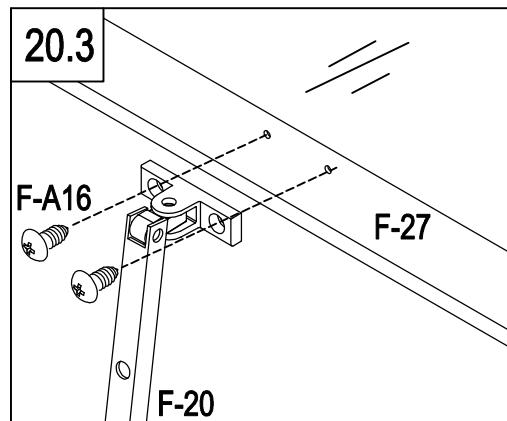

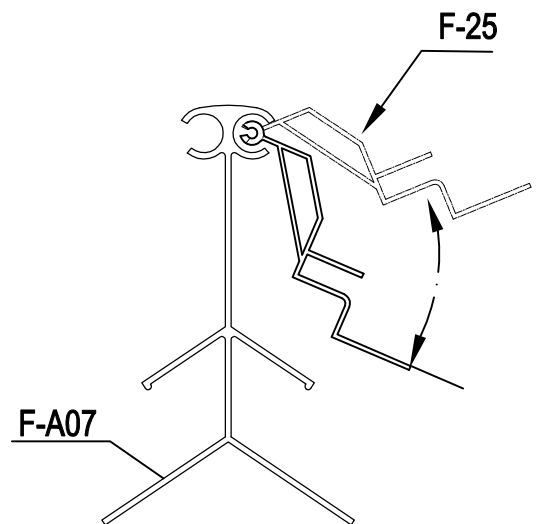
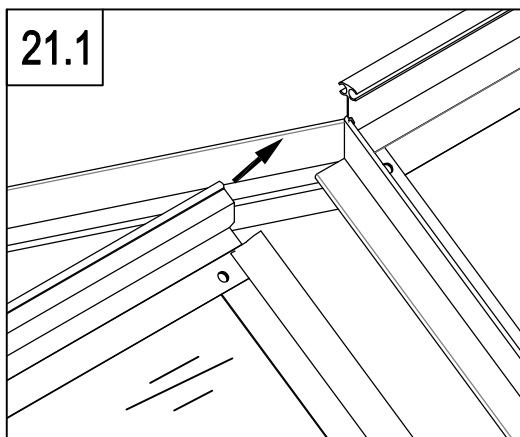
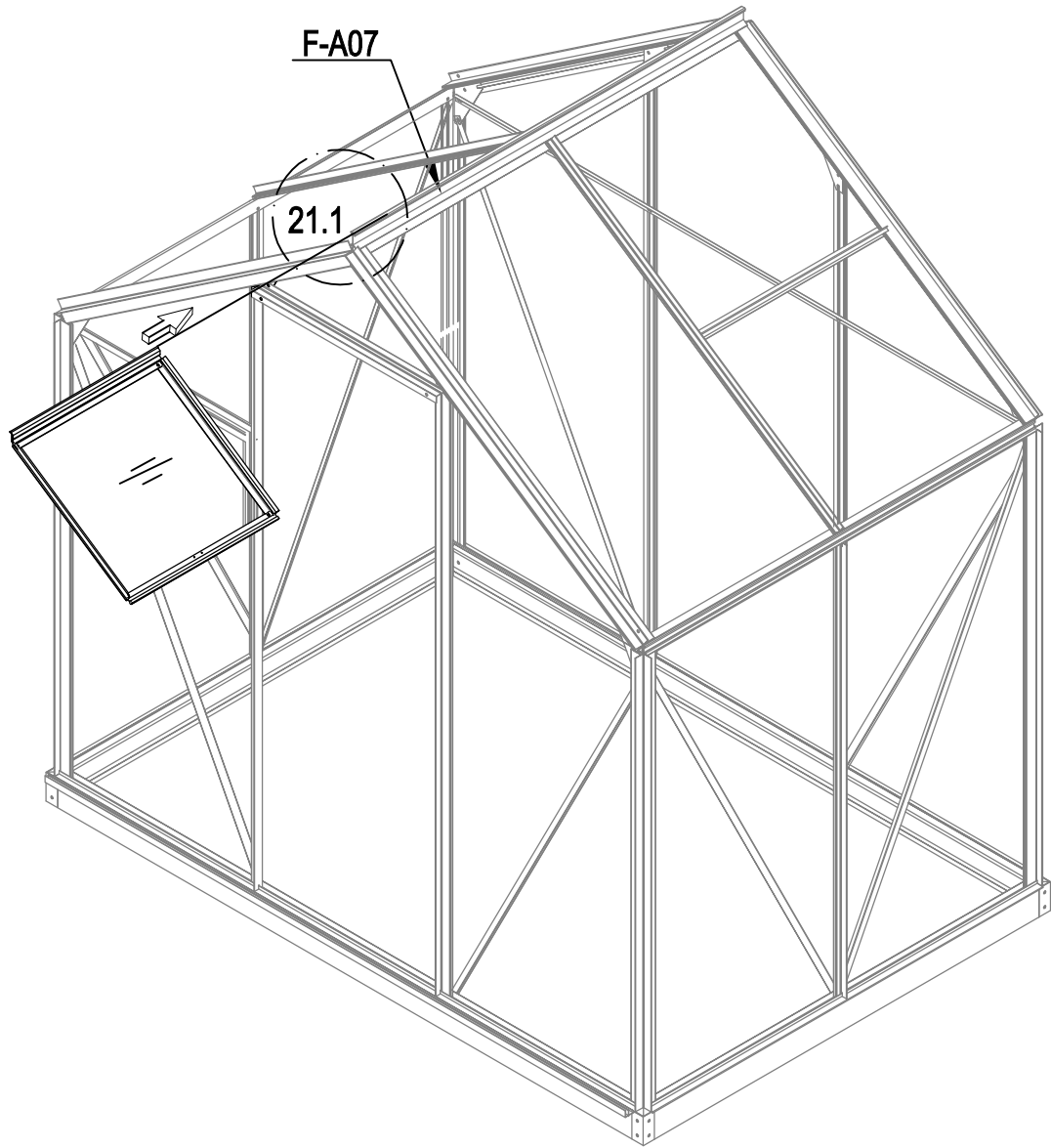

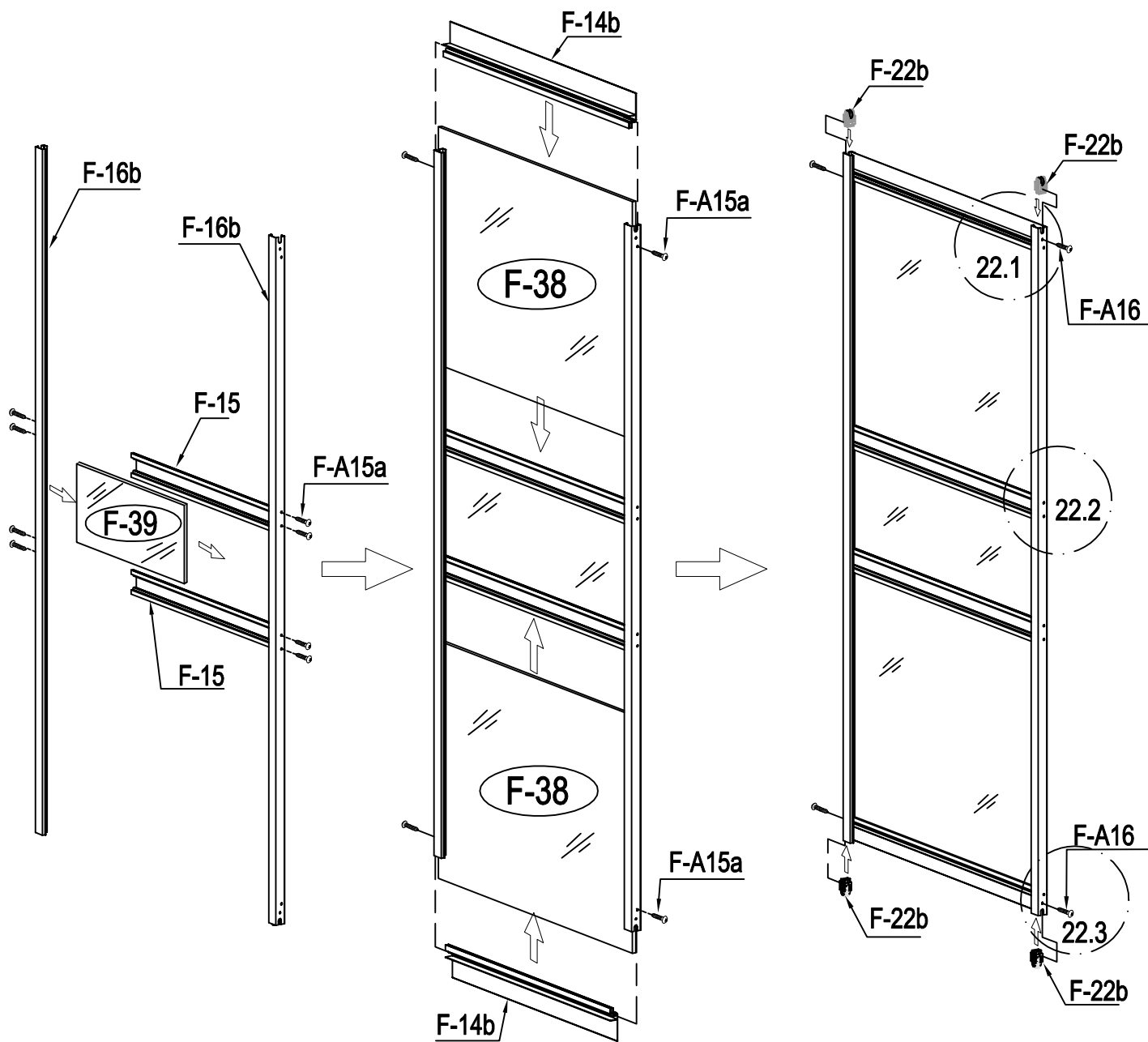

	F-25	1
	F-26	2
	F-27	1
	F-20	1
	F-37	1
	F-A16	2
	F-A14	4







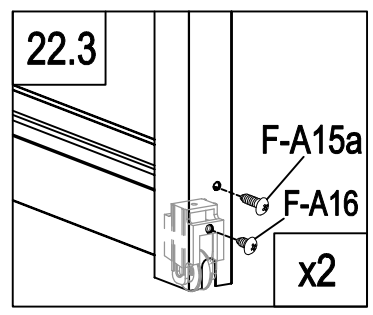
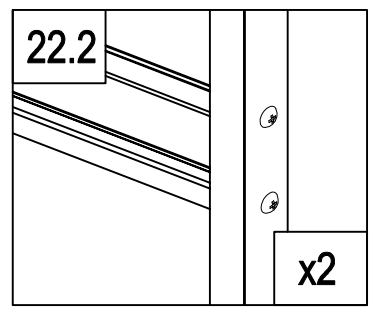
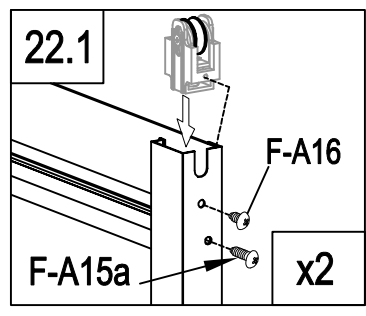

	F-38	2
	F-39	1
	F-16b	2
	F-14b	2
	F-15	2
	F-22b	4
	F-A15a	12
	F-A16	4

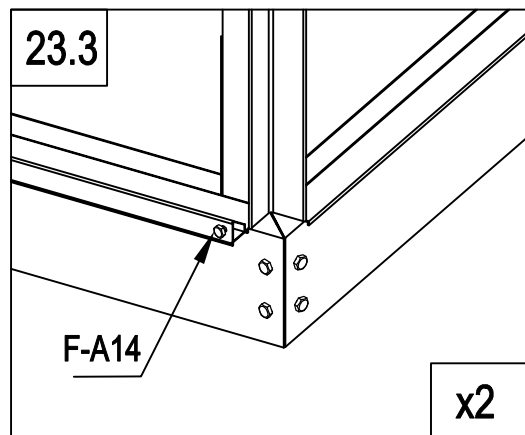
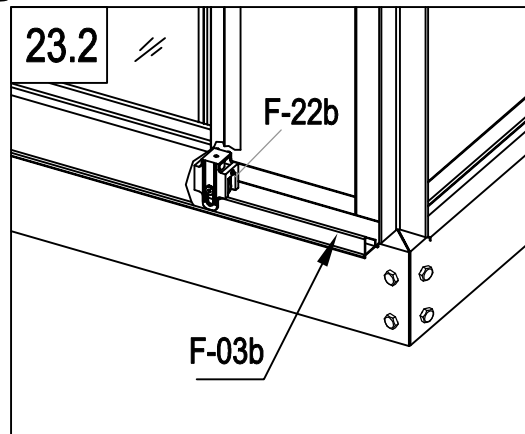
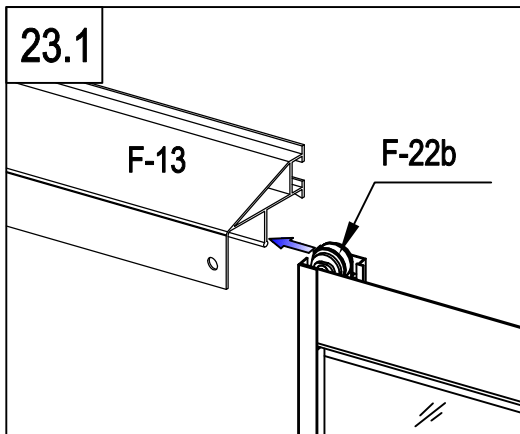
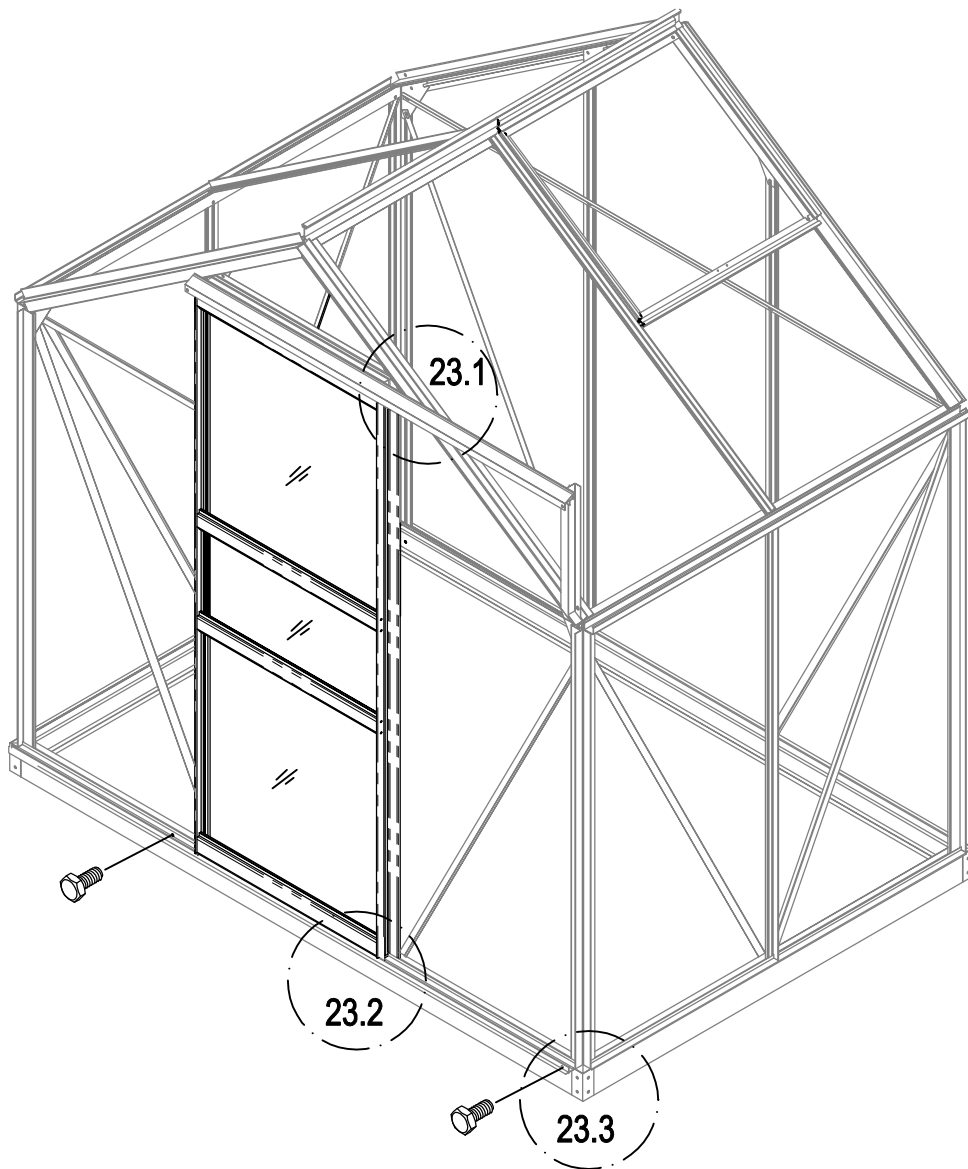





	F-A14	2
--	-------	---

23

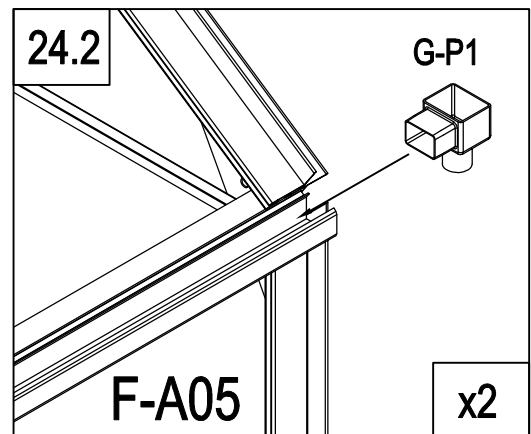
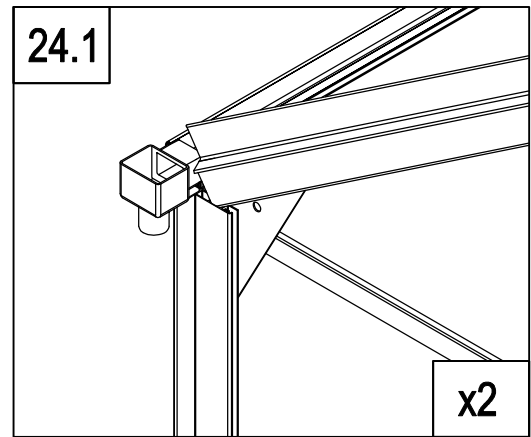
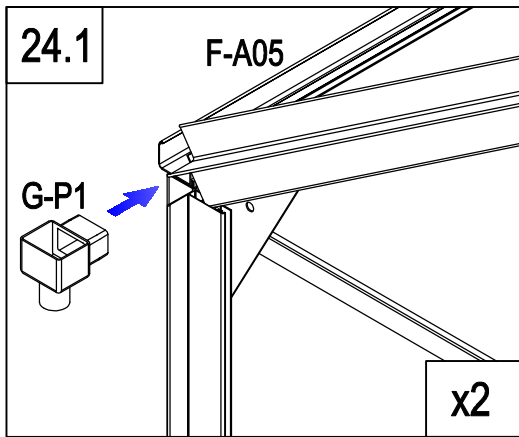
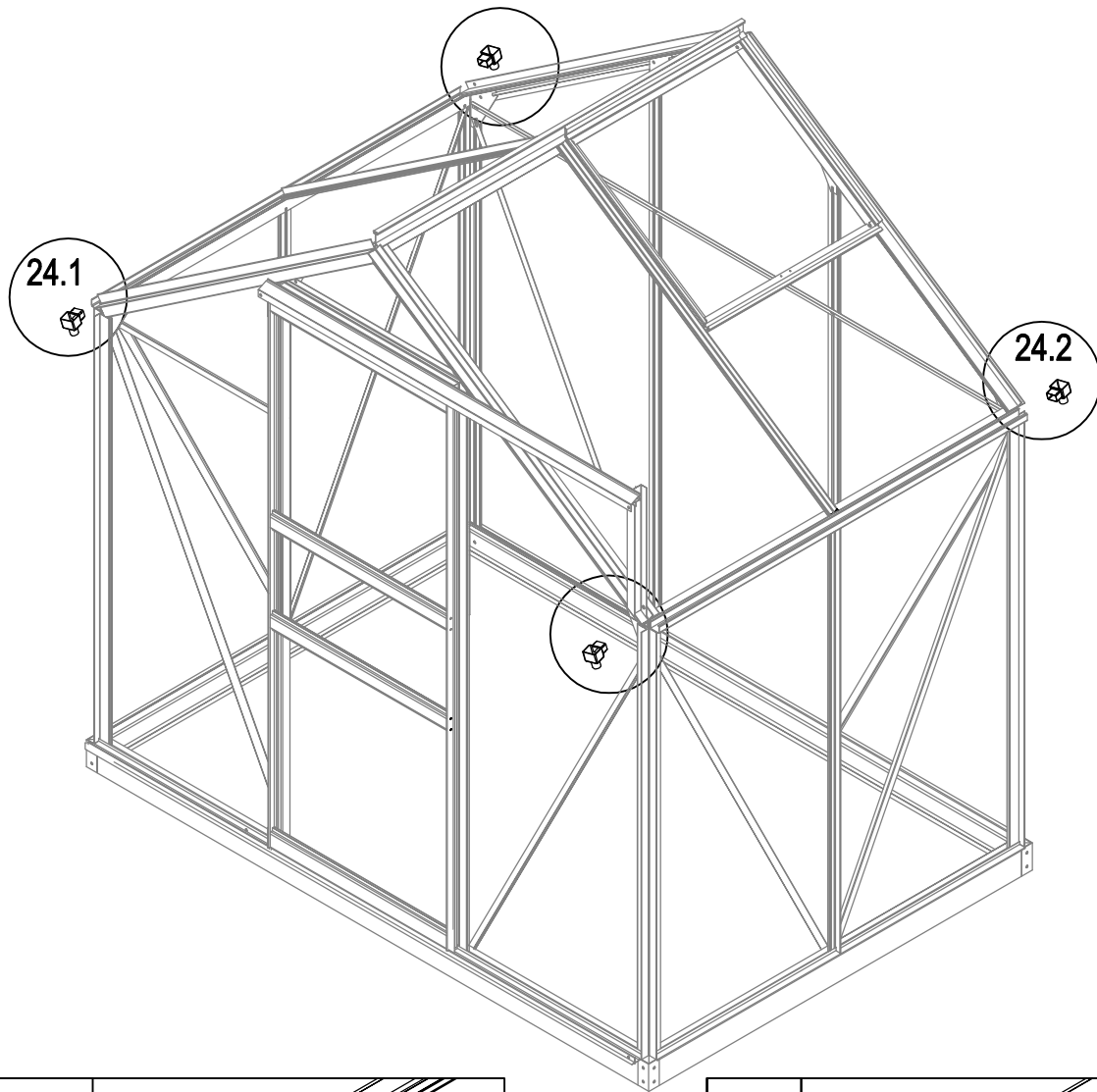
x2



	G-P1	4
---	------	---

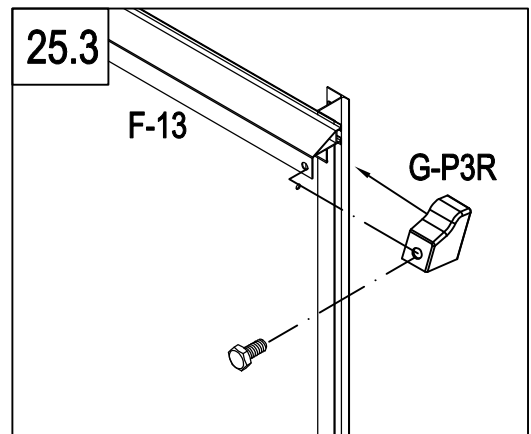
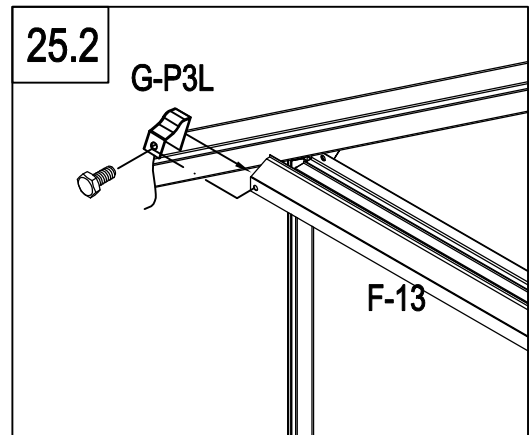
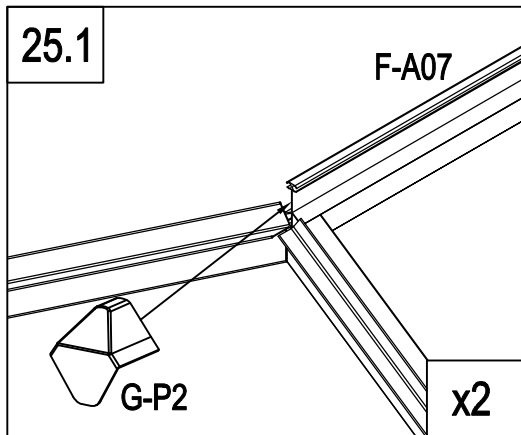
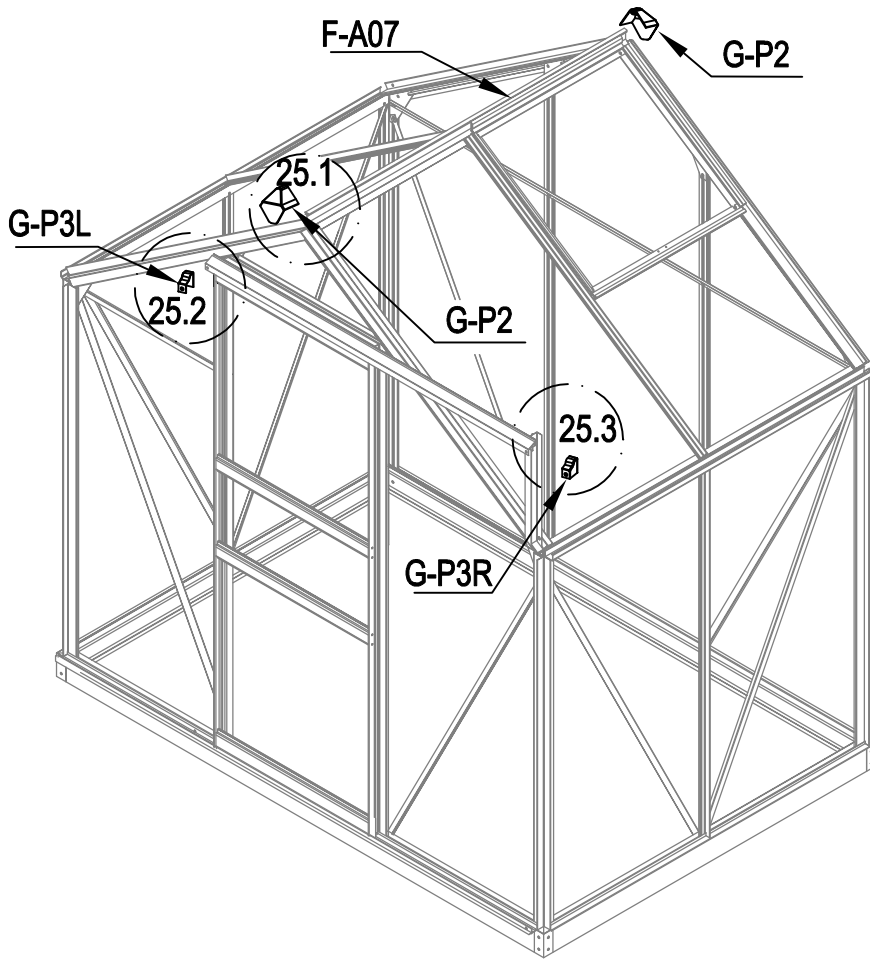

	G-P2	2
	G-P3L	1
	G-P3R	1
	F-A14	2

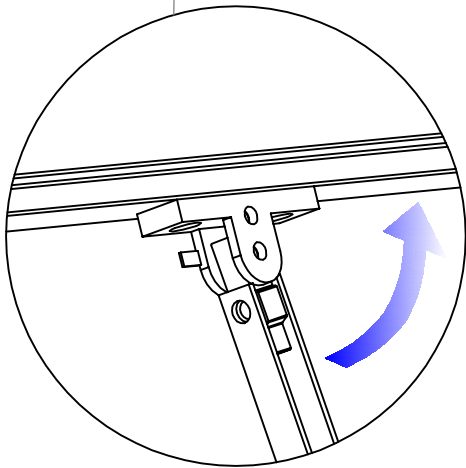
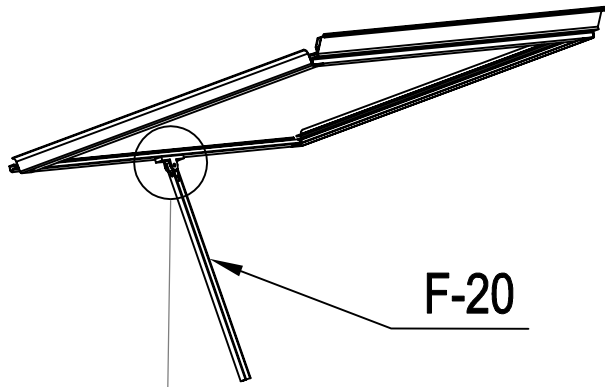

I

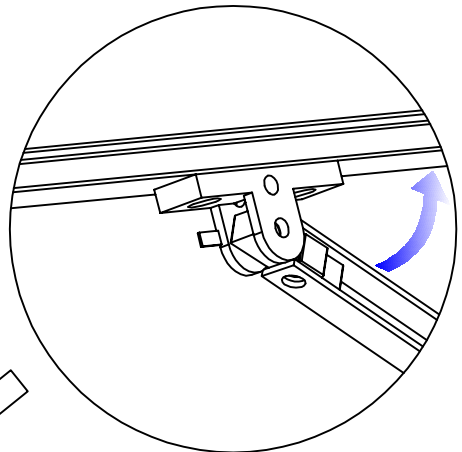
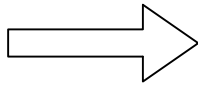

II

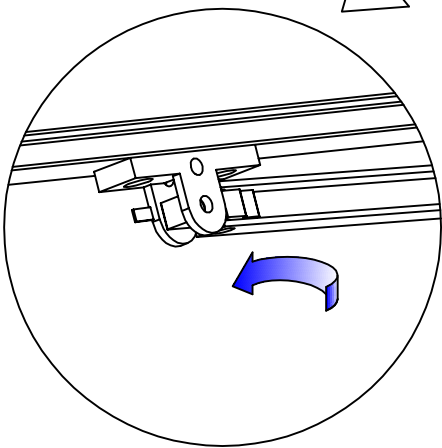
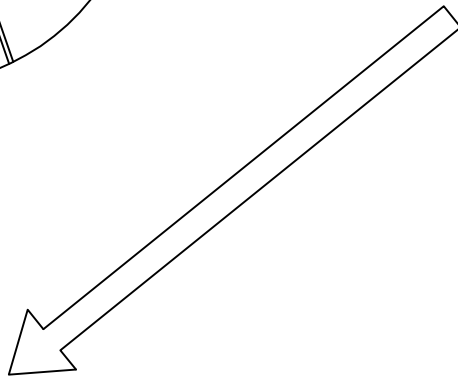

III

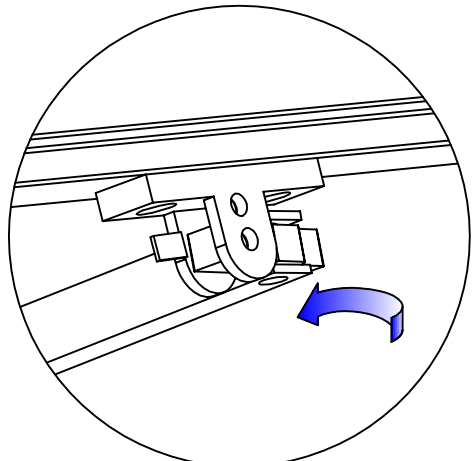
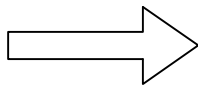

IV

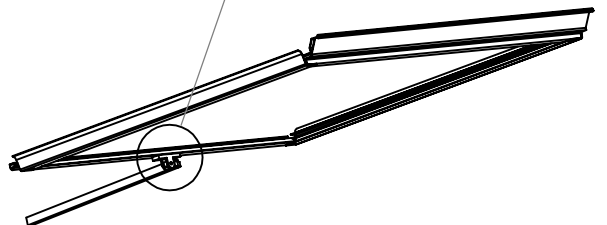

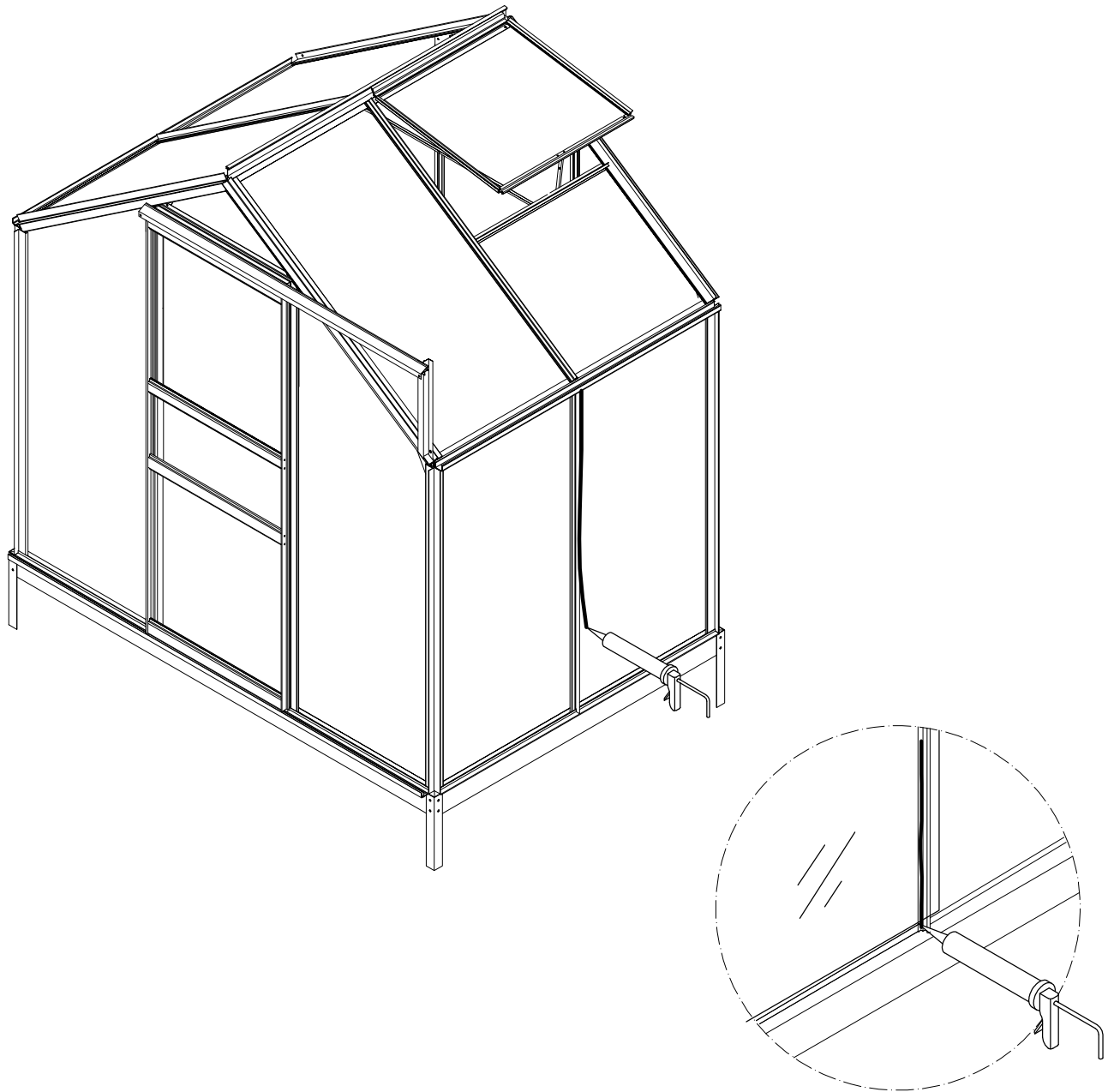

Advice

It is not necessary but we would advise:

For additional strength, you can also use some glue or tapes between the polycarbonate panel and the aluminum frame to enhance the stability.

Note: Silicone sealant and glue gun are not included in our tool kit. You can buy them locally.