

ASSEMBLY INSTRUCTION

ITEM NO RYS22

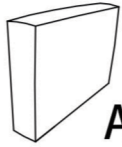

A x2

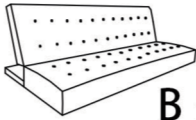

B x1

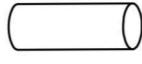

C x2



D x4

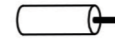

E x1

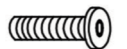

F x8



G x8



H x8



I x8



J x8



K x1

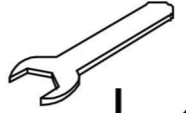

L x1

Step1

Please open the zipper and pick up the "A" "C" "D" "E" and "HARDWARE".

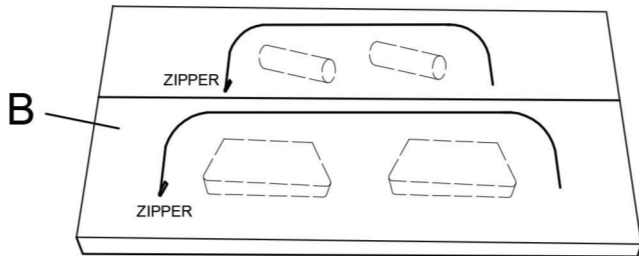

Step2

Assemble the legs.

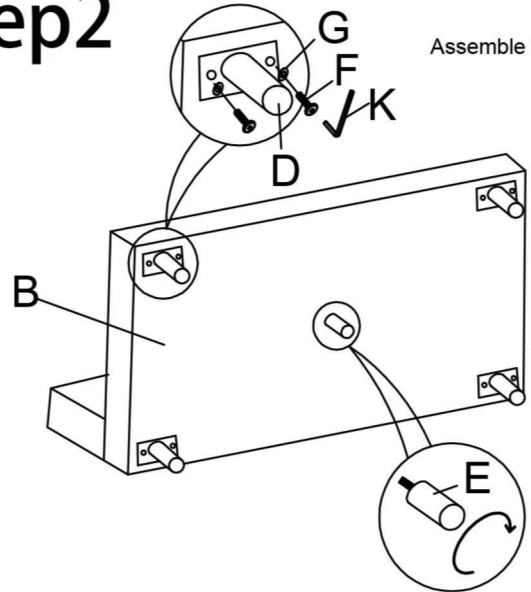

Step3

SCREW IN THE ARMS ABOUT 1CM FIRSTLY.

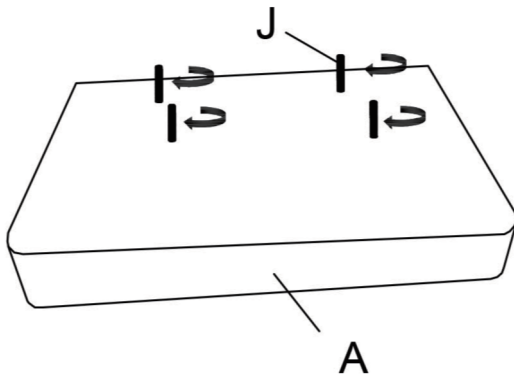

Step4

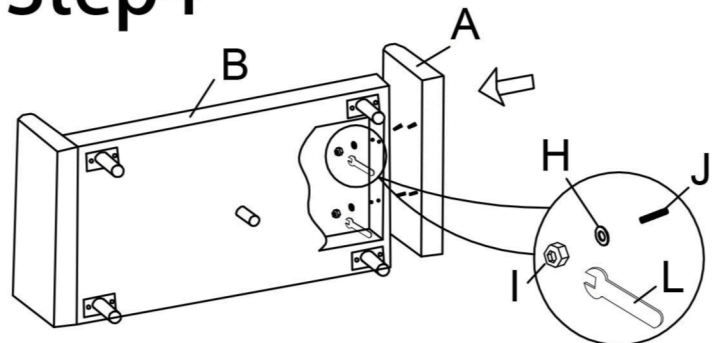

Insert the back with screw into the seat frame, then put the washer and tighten the nuts.

Step5

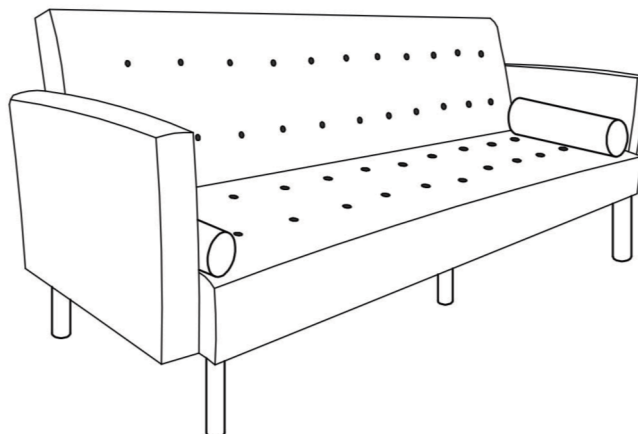

Assembly is finished.