

3 Pieces Rocker Set with Cushion

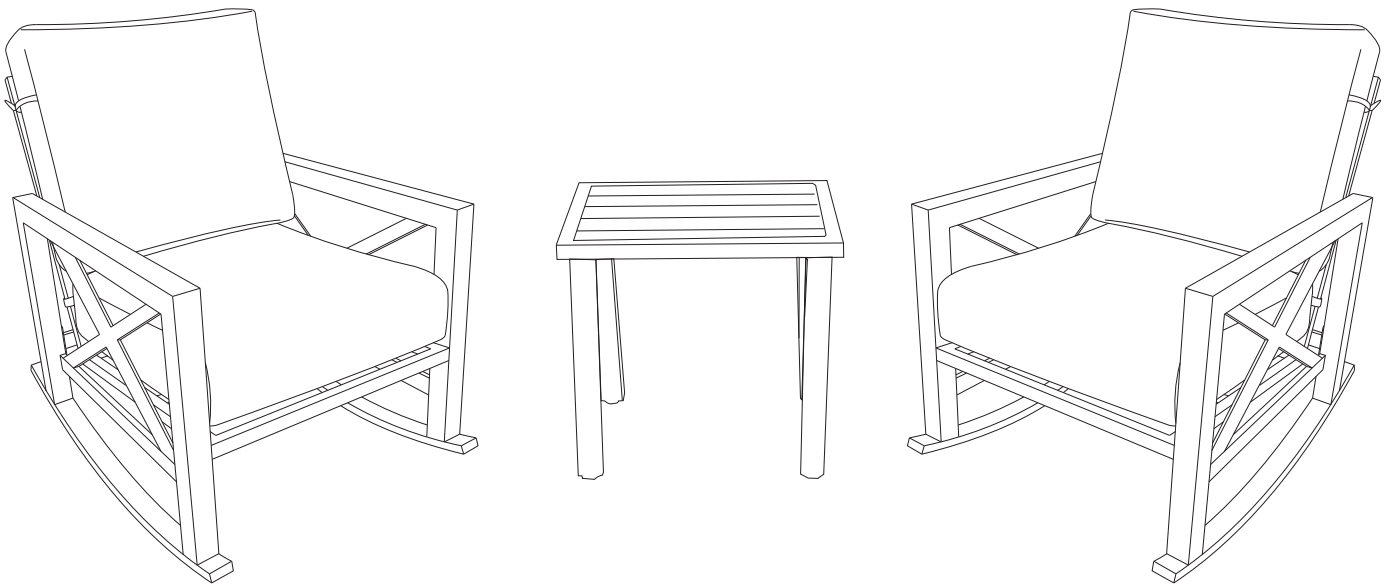













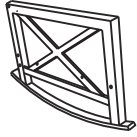

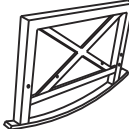
Assembly Instructions



WARNING

- 1. This set is mixed packed into 2 boxes, please wait one more day if does not arrive on the same day*
- 2. Please confirm all parts correct before assemble*
- 3. Do not tighten fastening fully until assembly is complete*
- 4. DO NOT USE POWER TOOLS. Power tools can overtighten screws and strip threads*

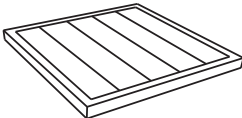
PARTS LIST

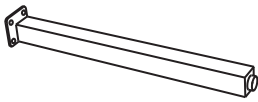
CODE	PARTS	QTY.	CODE	PARTS	QTY.
A	 Back	2PCS	AA	 Bolt Cap(M6)	40PCS
B	 Seat	2PCS	BB	 M6*20	8PCS
C	 Leg-L	2PCS	CC	 M6*30	12PCS
D	 Leg-R	2PCS	DD	 M6*45	4PCS
E	 Leg Connector	2PCS	EE	 M6*55	4PCS
F	 Back Cushion	2PCS	FF	 Washer(ϕ 6*12)	40PCS
G	 Seat Cushion	2PCS	GG	 Allen Key	1PC
H	 Tabletop	1PC	HH	 BOLT(M6*15)	12PCS
I	 Table Leg	4PCS			

1

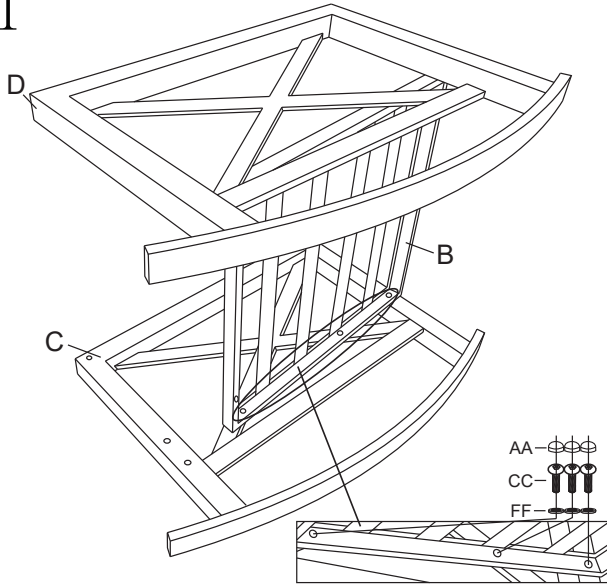

- Attached Seat (B) to the Leg-L (C) and Leg-R(D) with washers (FF)and bolts(CC) using Allen Key(GG)
- Tighten bolts using hex wrench and put bolt cap(AA) to all bolts.

2

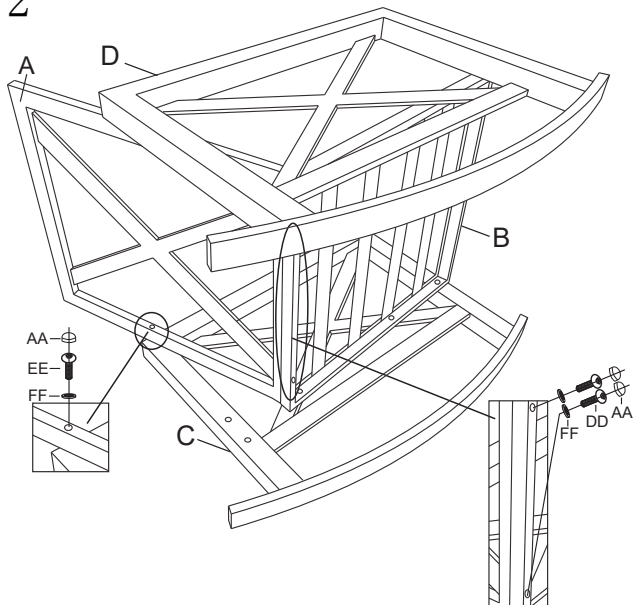

- Attached Back(A) to the Seat (B) with washers(FF) and bolts(DD), then attach to the Leg-L(C) and Leg-R(D) with washers (FF)and bolts(EE) using Allen Key(GG)
- Tighten bolts using hex wrench and put bolt cap(AA) to all bolts.

3

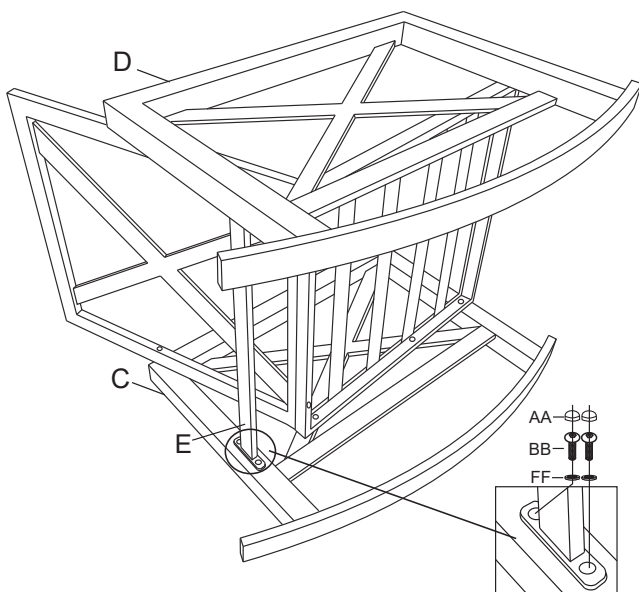

- Attached Leg Connector(E) to the Leg-L(C) and Leg-R(D) with washers (FF)and bolts(BB) using Allen Key(GG)
- Tighten bolts using hex wrench and put bolt cap(AA) to all bolts.

4

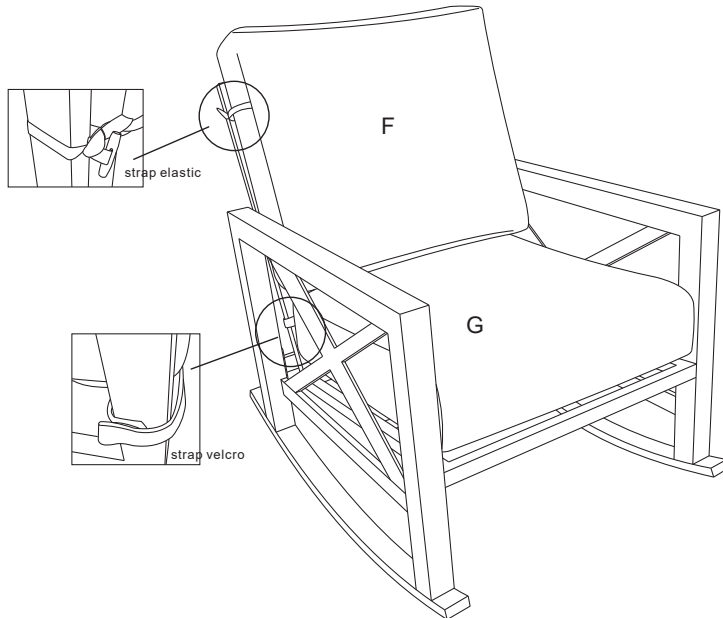

- Put Seat Cushion(G) and Back Cushion(F), then tie to the back with strap elastic/velcro

5

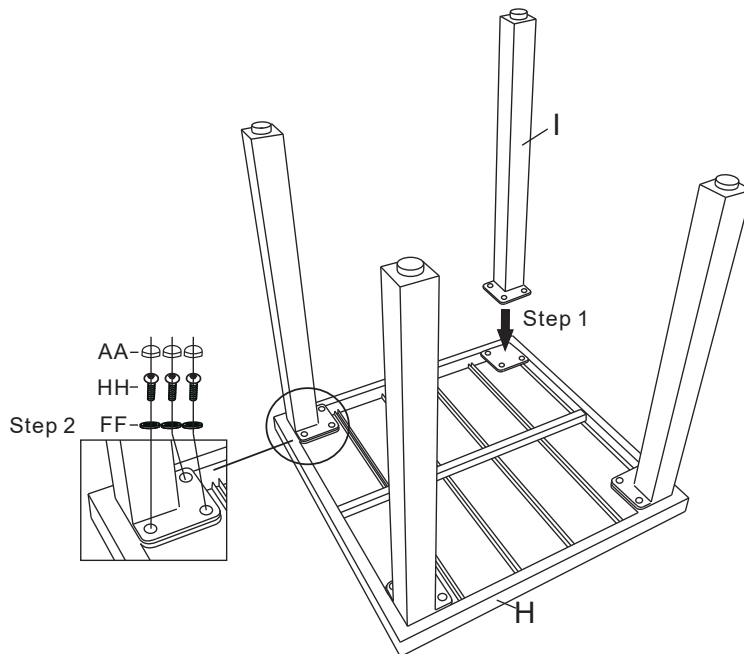

- Attach Leg(I) to Tabletop(H) with washers(FF) and bolts(HH) using Allen Key(GG)
- Tighten bolts using hex wrench and put bolt cap(AA) to all bolts

6

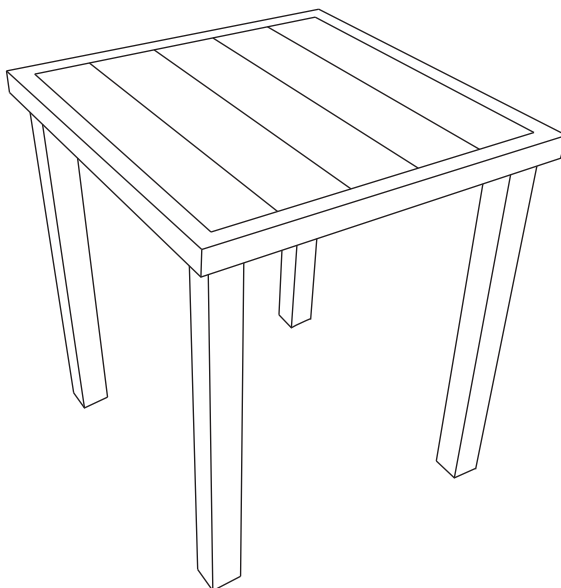

- Turn the table upright. If necessary level the table with adjustable feet cap at the bottom of each table leg.