

Assembly Instructions

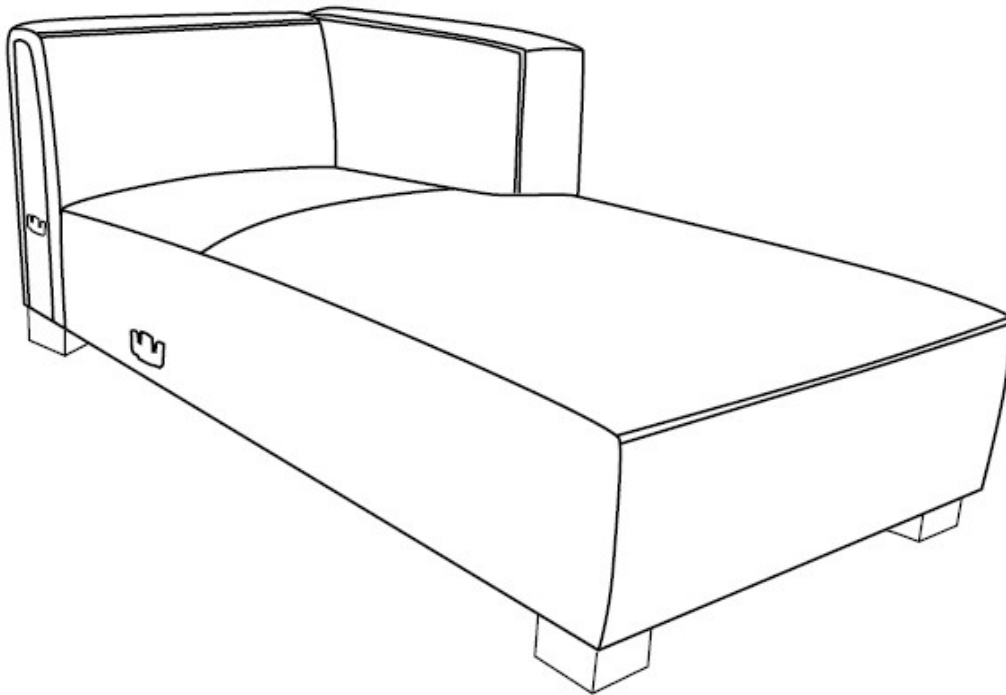

Caution: You must read this before you proceed

Please look in the magic tape pouch for hardware packs and legs



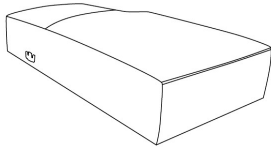
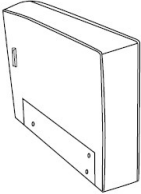
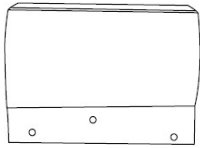

CHAISE LOUNGE



Part List

Label	Picture	Description	QTY
A		Chaise Seat	1
B		Chaise Arm Rest	1
C		Chaise Back Rest	1
D		Leg	5

Hardware List

Label	Picture	Description	QTY
①		Bolt(M8*60MM)	12
②		Flat Washer Ring	12
③		Spring Washer Ring	12
④		Allen Wrench	1

Assembly Preparation

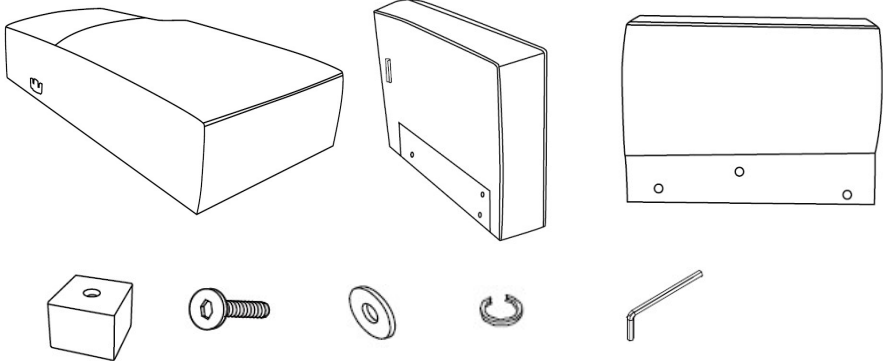
<p>Before Beginning Assembly:</p>					
	X5	X12	X12	X12	X1



- Read instructions, cover to cover-



- Have 2 adults on hand for assembly-



- Do not assemble on flooring or carpet-



- Assemble on a clean non-marring surface (packing foam)-



- Save all packaging until finished-

Assembly Steps

OVERVIEW

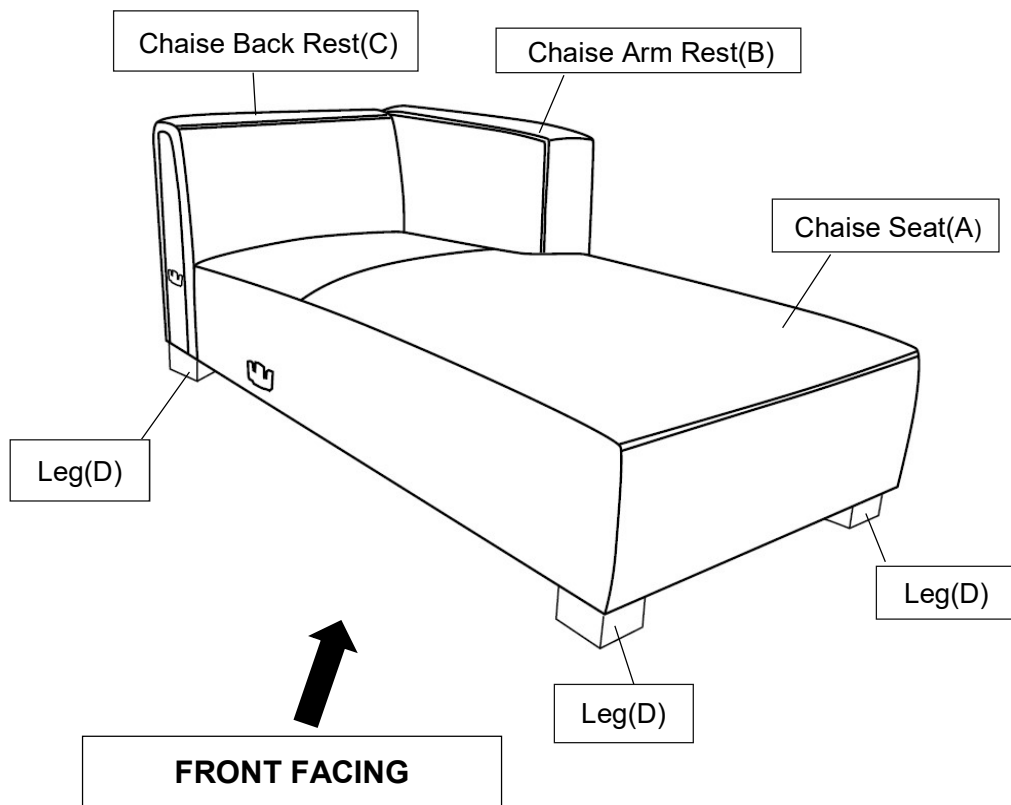

This Chaise Lounge has multiple parts and may require up to 60 minutes to assemble. To give you an overview of the Chaise Lounge parts, the above picture is to help you put the various parts into perspective. Please read through the instructions below to familiarise yourself with the parts and steps before assembly.

Note: It is recommended that you have an adult partner to assist during the entire assembly process.

Step 1

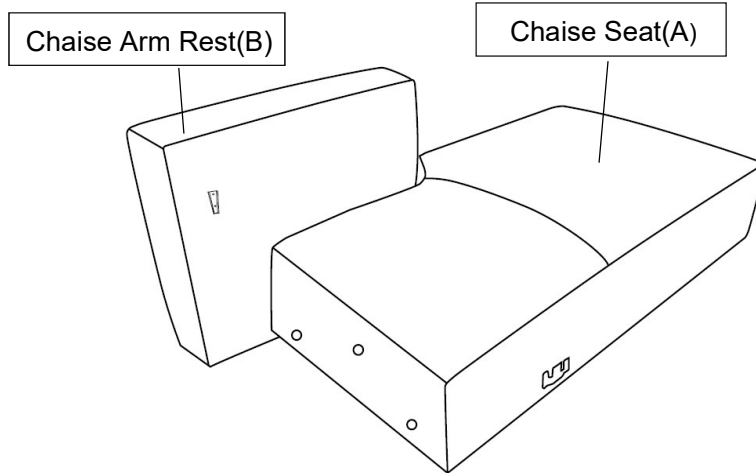

Open the carton and place all the parts on a clean, non-marring surface.
Position the Chaise Arm Rest(B) and the Chaise Seat(A) as shown above.

Step 2

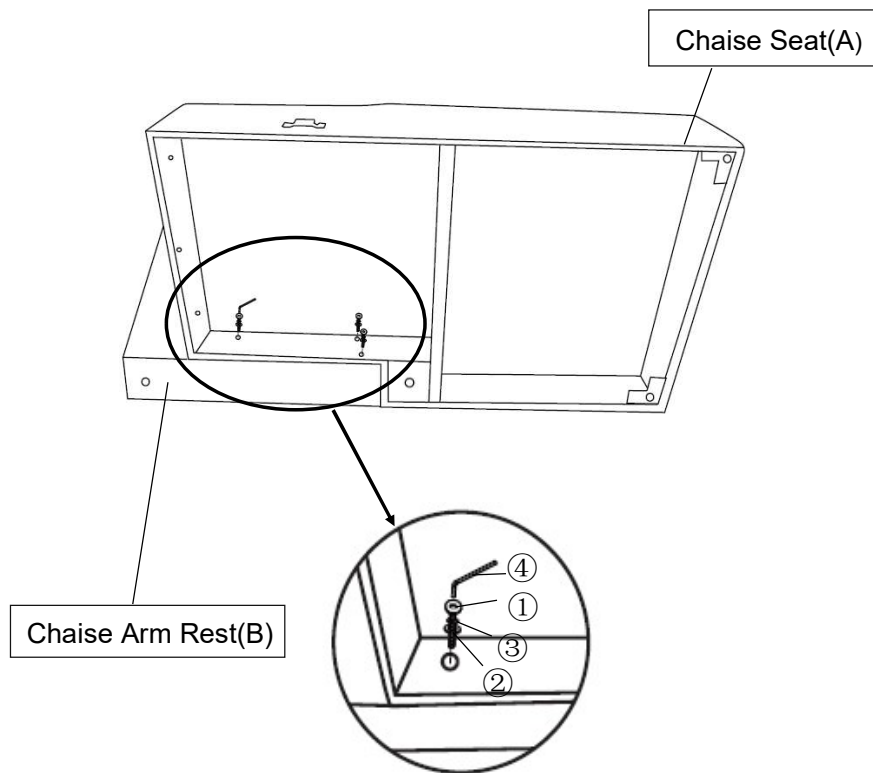

Attach the Chaise Seat(A) to the Chaise Arm Rest(B) using Bolts(①), Spring Washer Rings(③), Flat Washer Rings(②) and the Allen Wrench(④).
Tighten all Bolts(①) using Allen Wrench(④).

Step 3

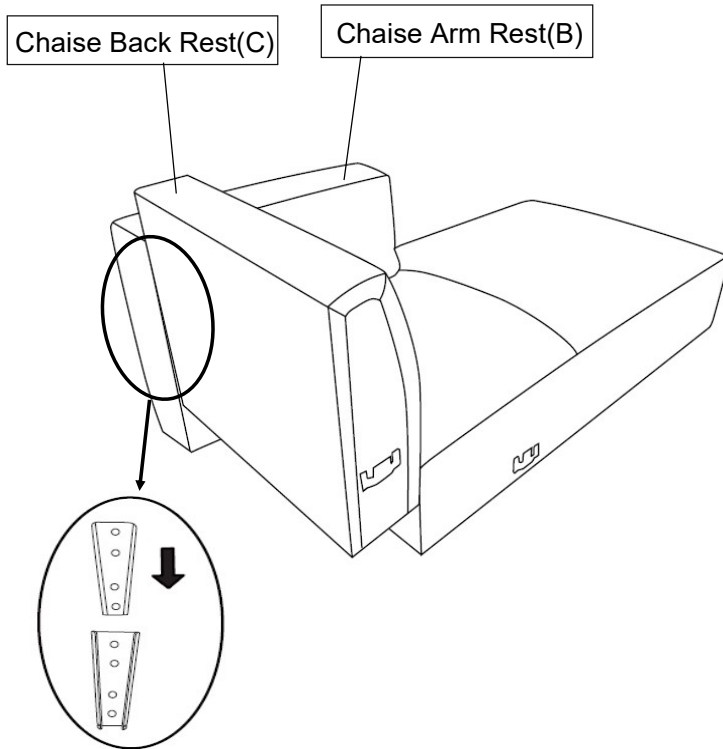

Slide the Tapered Connectors on the Chaise Back Rest(C) into the Tapered Connectors on the Chaise Arm Rest(B) as shown in the picture.

Note: Ensure the Tapered Connectors on the Chaise Back Rest(C) lock into the Tapered Connectors on the Chaise Arm Rest(B).

Assistance from an adult partner is necessary for this assembly process.

During this assembly process - do exercise caution. You may need to use your hand to press down and or pave away the padded surface to facilitate the 'slip and slide' assembly.

Caution: Ensure that your fingers do not get caught or pinched in the assembly process.

Step 4

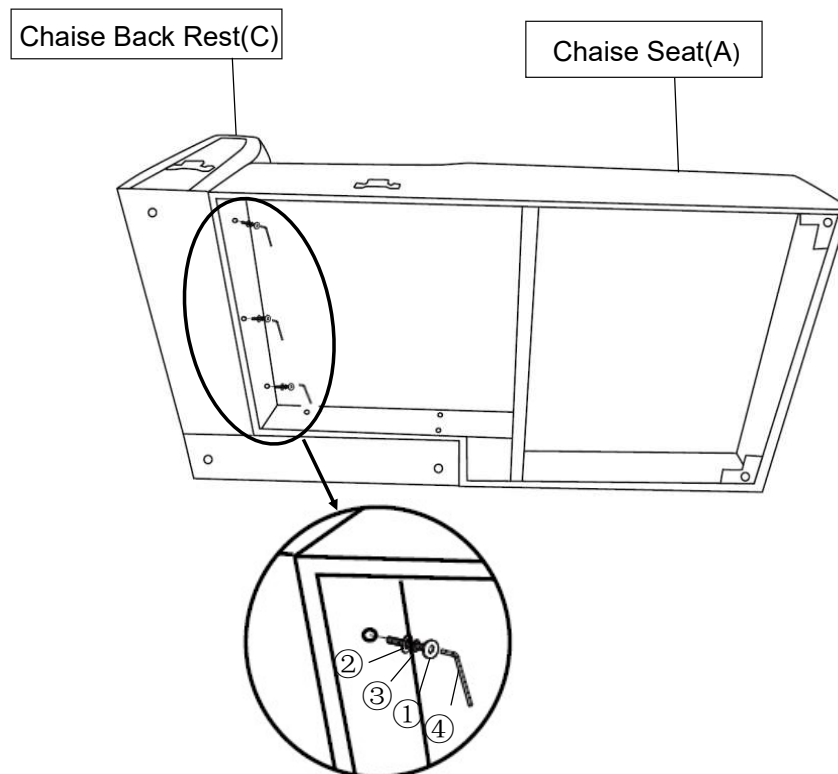

Position the Chaise Seat(A) as shown above.
Attach the Chaise Back Rest(C) to the Chaise Seat(A) using Bolts(①), Spring Washer Rings(③), Flat Washer Rings(②), and the Allen Wrench(④).
Tighten all Bolts(①) using the Allen Wrench(④).

Step 5

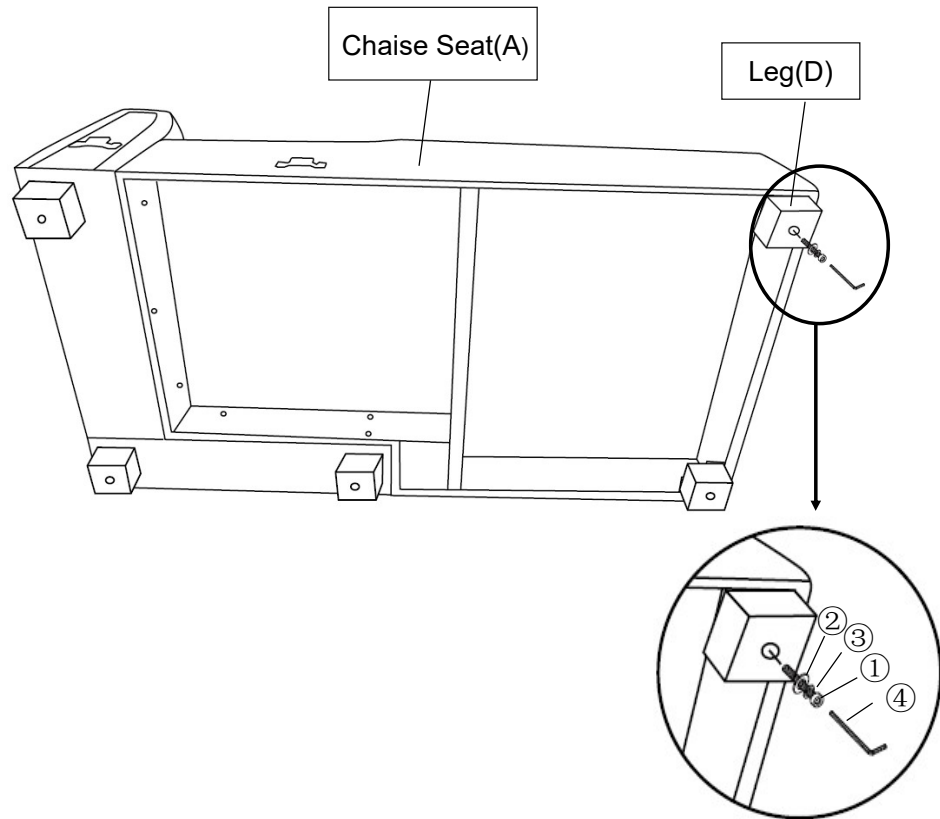

Install the Leg(D) to the Chaise Seat(A) using a Bolt(①), Spring Washer Ring(③), Flat Washer Ring(②) and the Allen Wrench(④) turning clockwise until tight.
Repeat the same step to the remaining Legs(D).
Position the Chaise Seat(A) right side up.

Step 6

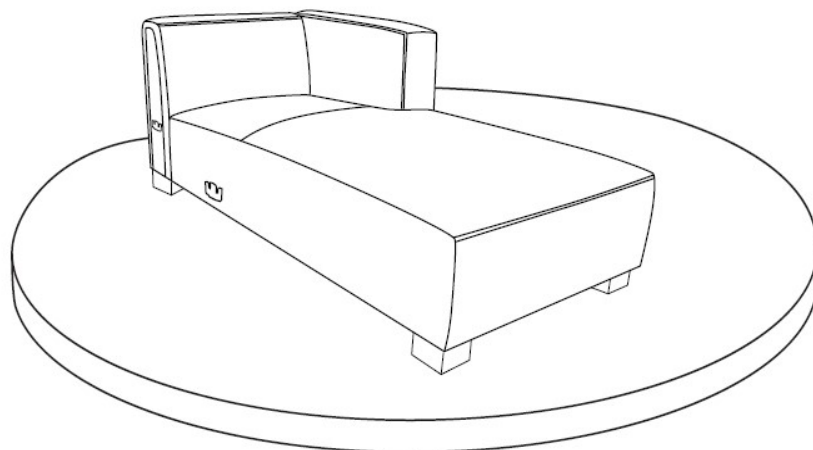

Position the Chaise Lounge right side up and test for stability.
Notice: If a leg is found to not be level, slightly loosen the bolts under the lounge, press the Backrest, Arm or Seat to adjust until all 4 legs are level, then tighten all the bolts.

Step 7

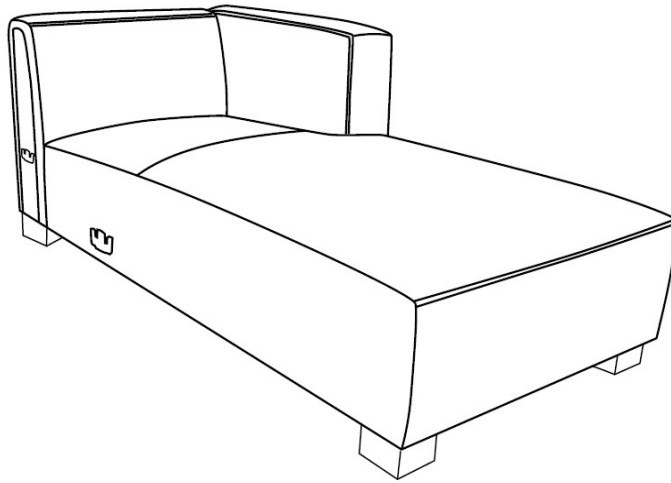

Your Chaise Lounge is ready for use.

This Chaise Lounge can only be used on a flat, level surface.

This Chaise Lounge can be combined with a Left Arm Sofa into a sectional sofa. If you bought a Left Arm Sofa at the same time, read on.

Step 8

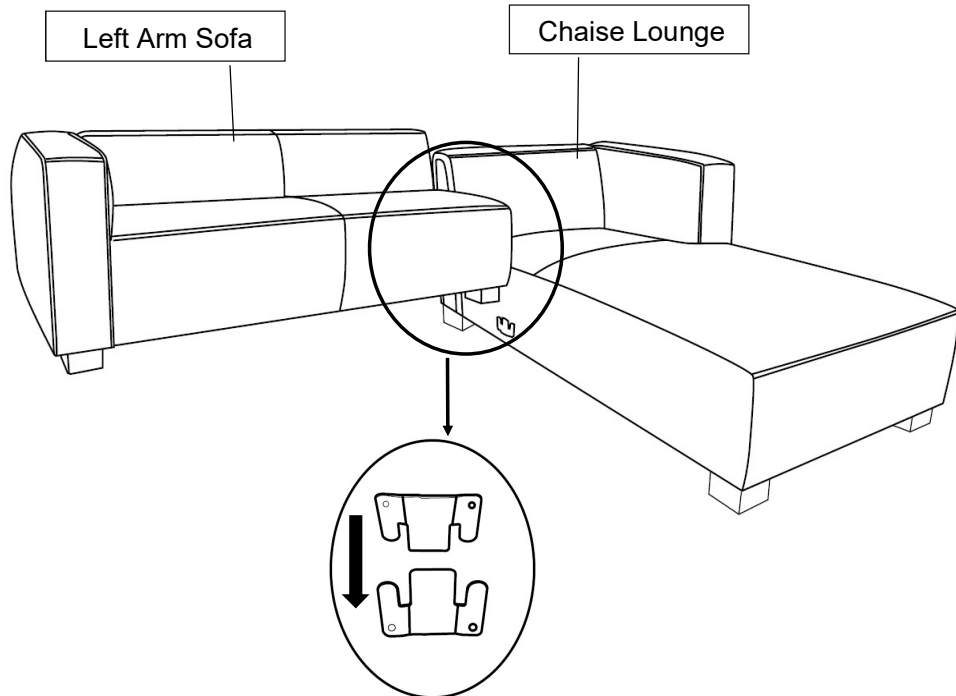

Slide the Tapered Connectors on the Left Arm Sofa into the Tapered Connectors on the Chaise Lounge as shown in the picture.

Note: Ensure the Tapered Connectors on Left Arm Sofa lock into the Tapered Connectors on the Chaise Lounge.

Assistance from an adult partner is necessary for this assembly process.

During this assembly process - do exercise caution. You may need to use your hand to press down and or pave away the padded surface to facilitate the 'slip and slide' assembly.

Caution: Ensure that your fingers do not get caught or pinched in the assembly process.

Step 9

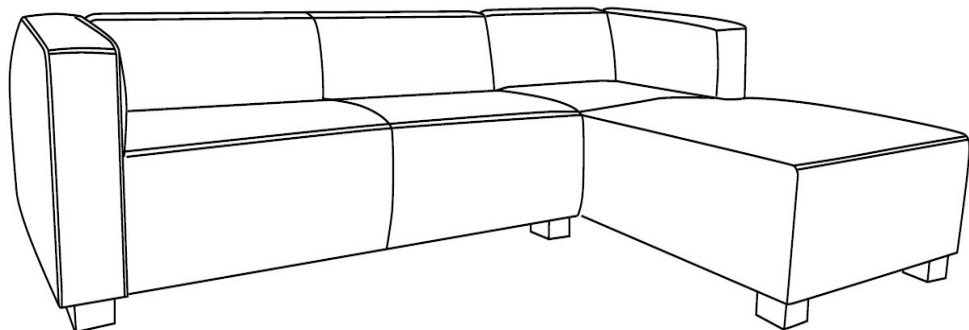

Your Sectional Sofa can be used as picture showned.

Care & Maintenance



- Furniture may scratch floors. We recommend using furniture pads to protect your floors.



- Do not put hot items directly on furniture surface.



- Do not clean furniture with harsh cleansers or polish.



- Do not place furniture under direct sunlight.



- Do not place furniture near heating or cooling vents.



- Do not write on furniture without a padded barrier to protect the surface.



- Do not place furniture outside . For indoor use only.



- Not for commercial use. For residential use only.



- Stains may be removed with mild soap solution and damp cloth.



- Children should not climb or jump on the furniture.



- Dust and pick-up spills using a clean, non-colored, lint-free cloth.