





ASSEMBLY INSTRUCTIONS

MODEL : DINING CHAIR

IMPORTANT NOTE :

- * PLACE ALL WOODEN PARTS ON A CLEAN AND SMOOTH SURFACE SUCH AS A RUG OR CARPET TO AVOID THE PARTS FROM BEING SCRATCHED.
- * BEFORE YOU BEGIN, KINDLY FOLLOW THE ASSEMBLY INSTRUCTIONS STEP BY STEP.
- * DO NOT TIGHTEN ALL SCREWS UNTIL THE CHAIR IS FULLY SET-UP.

HARDWARE LIST			PART LIST		
A	JCBC M6 x 25mm + S/W M6 + F/W M6 x 13mm 	4PCS	1	RIGHT SIDE FRAME	1PC
B	JCBC M6 x 50mm + S/W M6 + F/W M6 x 13mm 	4PCS	2	LEFT SIDE FRAME	1PC
C	ALLEN KEY M4 (Ball Shape) 	1PC	3	FRONT STRETCHER	1PC
D	L BRACKET 	4PCS	4	BACK STRETCHER	1PC
E	CSK SCREW M3.5 x 12mm 	8PCS	5	TOP REST	1PC
			6	CUSHION SEAT	1PC

CAUTIONS :

(1) DO NOT FULLY-TIGHTEN THE NUT OR NUT BOLTS INITIALLY UNTIL ALL NUTS OR BOLT IS READY ASSEMBLED.

(TO AVOID CAUSING DAMAGES TO THE THREAD, DO NOT OVER-TIGHTEN THE NUTS OR BOLTS.)

(2) KEEP ALL HARDWARE PART OUT OF REACH OF CHILDREN.

STEP 1

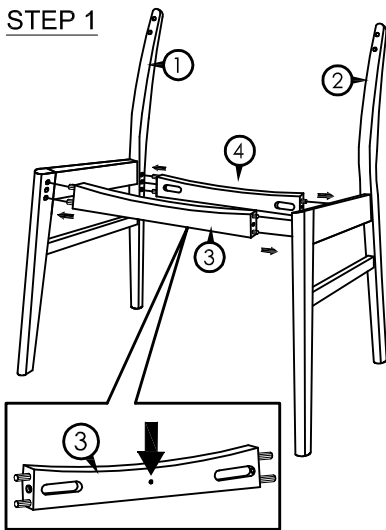

Front Stretcher (3) has a small hole for identification.

STEP 2

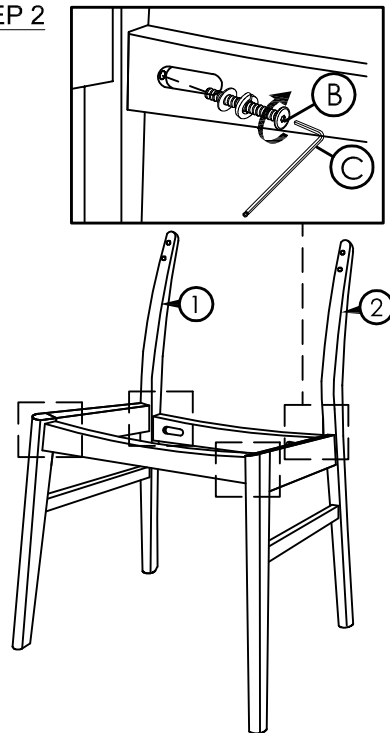

STEP 3

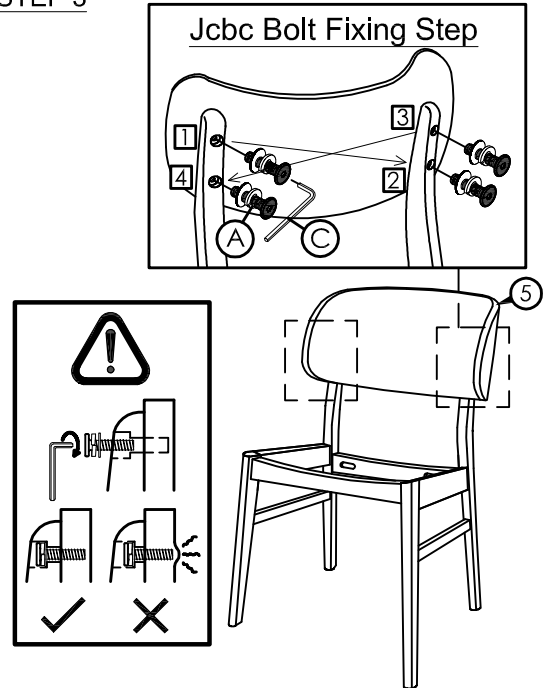

STEP 4

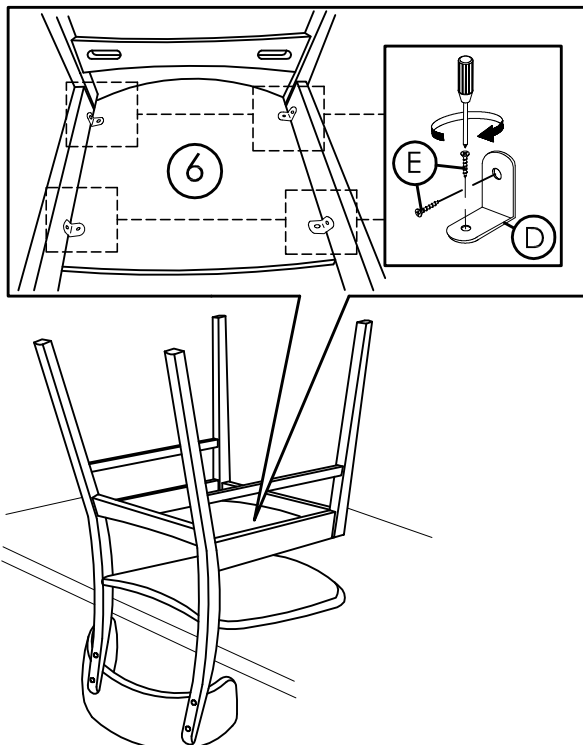

STEP 5

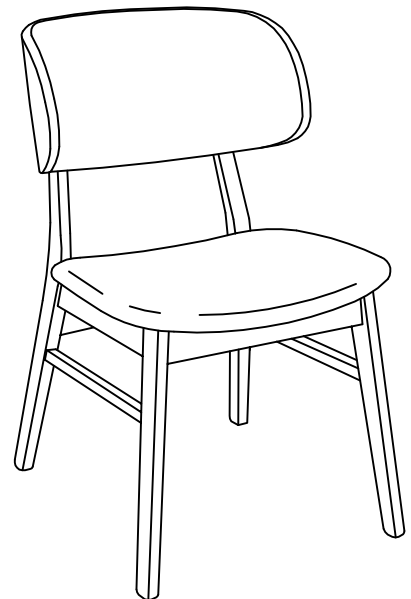

COMPLETED CHAIR ASSEMBLY.



ASSEMBLY INSTRUCTIONS

MODEL : DINING TABLE

IMPORTANT NOTE :

- * PLACE ALL WOODEN PARTS ON A CLEAN AND SMOOTH SURFACE SUCH AS A RUG OR CARPET TO AVOID THE PARTS FROM BEING SCRATCHED.
- * BEFORE YOU BEGIN, KINDLY FOLLOW THE ASSEMBLY INSTRUCTIONS STEP BY STEP.

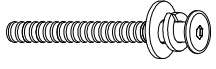
HARDWARE LIST

A	JCBB M8 x 80mm + S/W 5/16" + F/W 5/16" x 22mm 	8PCS
B	ALLEN KEY M5 	1PC



COMPLETED TABLE ASSEMBLY.

PART LIST

1	TABLE TOP	1PC
2	TABLE LEG	4PCS

INSTRUCTION :-

(STEP 1)

Place Table Top (1) face down on a clean and flat surface to prevent from being scratched.

(STEP 2)

Position Table Leg (2) with D-Nut holes facing to Corner Block holes of Table Frame , then insert JCBB Screw (A) + Spring Washer + Flat Washer then tighten with Allen Key (B) provided.

(STEP 3)

Repeat Step 2 for other 3 legs assembly.

(STEP 4)

Revert the table for completion of table assembly.

