

Computer Desk

User Manual

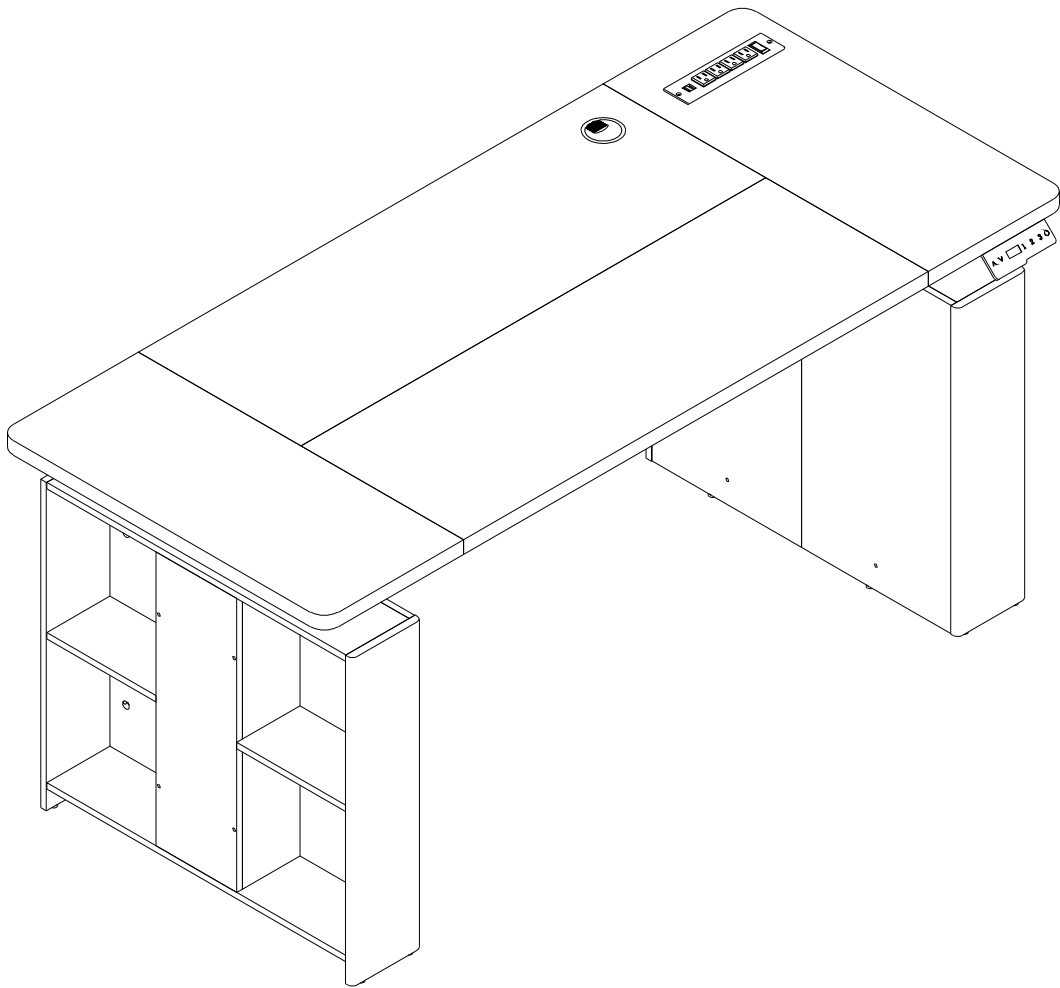

Installation takes  x 2~4hour

 Please read this instruction manual carefully before using the product

Package Contents

Plates and
iron components

Assembly tool kit

Instruction manual

⚠ Precautions

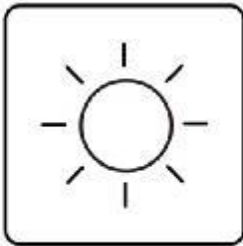

1. Avoid extended periods of direct sunlight exposure.



2. Stay away from fire.

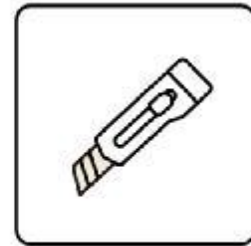

3. Keep away from sharp objects.

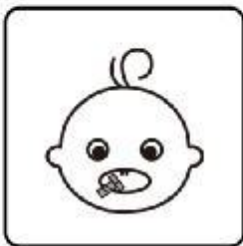

4. Keep infants and children away from assembly parts to avoid choking and suffocation.



5. Keep away from corrosive substances.

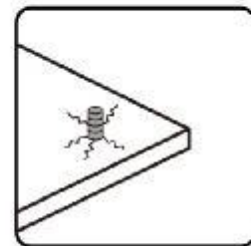

6. Pay attention to avoid over-tightening fasteners, as they may cause cracking within the board.

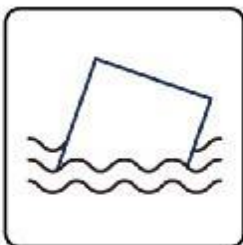

7. Prevent objects from being damaged by immersion in water.

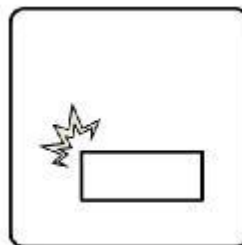

8. Prevent object collision and damage.



9. Be careful to avoid collisions.

⚠ Installation of Cams and Pins

Be sure to use the proper screws to avoid damaging the parts

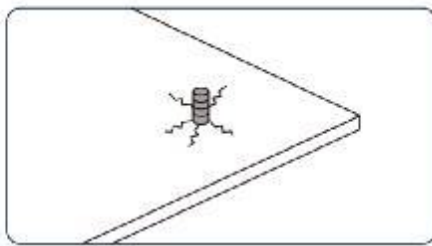
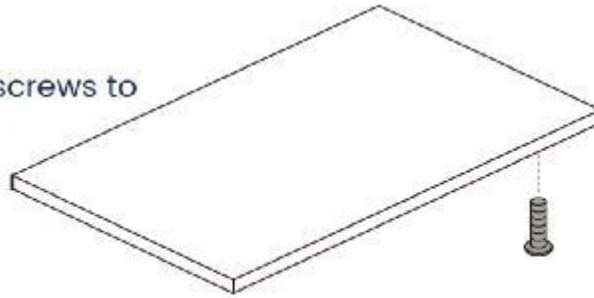

Wrong screws can cause the plank to crack

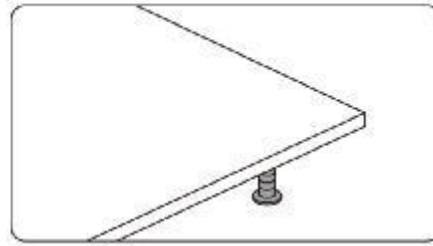

The right screw is the right size

⚠ Matters needing attention

1. When installing the screws in the installation step, the screws do not need to be tightened.

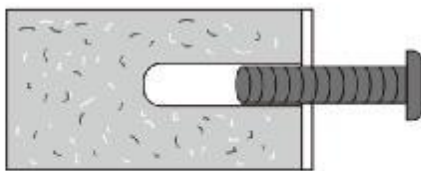

2. After this installation step is confirmed and the holes are aligned, then tighten all the screws.



3. If the screws are tightened during the installation process, it will cause problems such as misalignment of the screw holes and misalignment of the board in subsequent installations

Disassembly Diagram

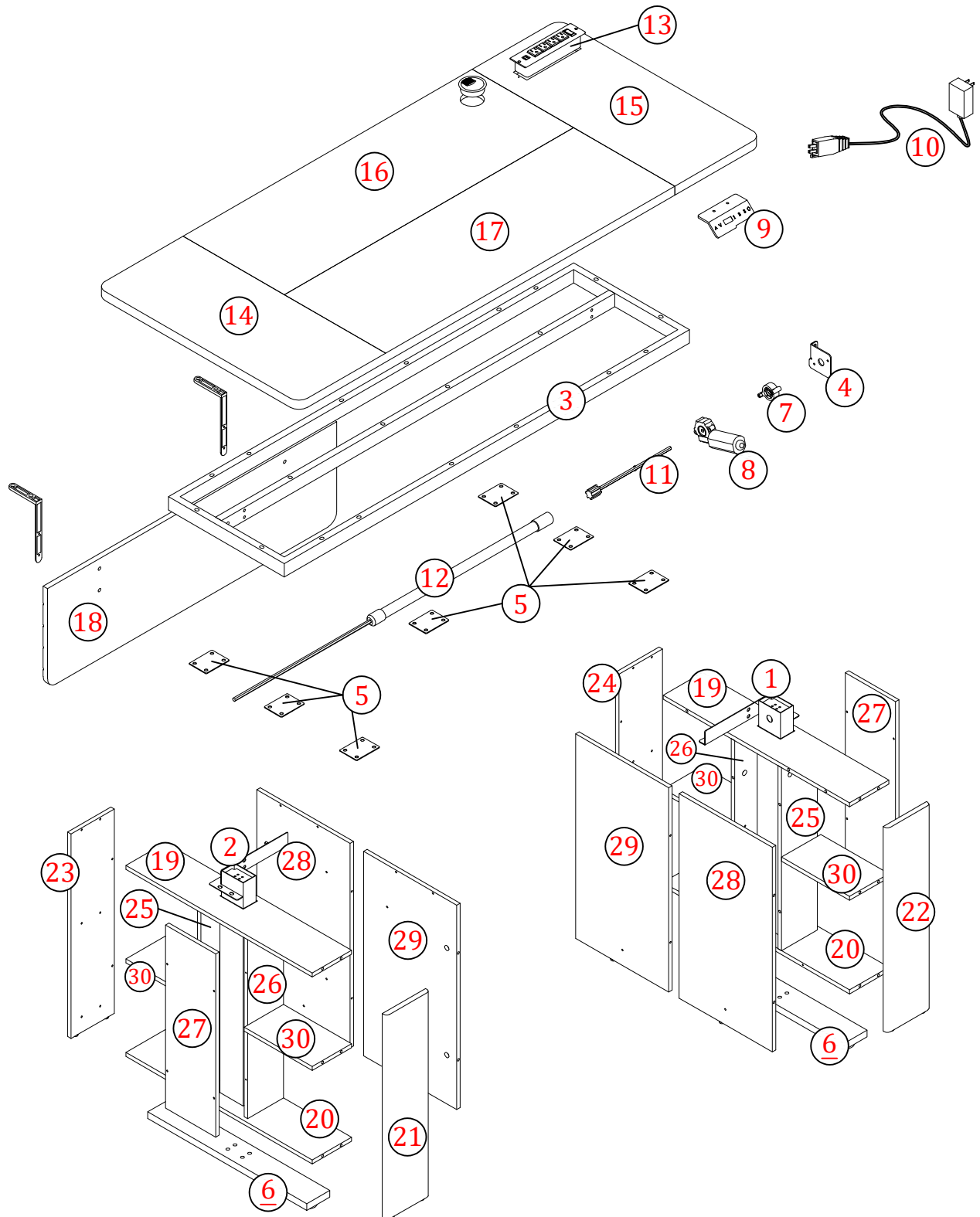

3

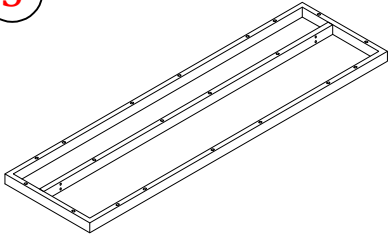

x 1

4

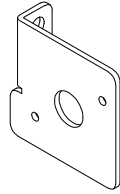

x 1

5

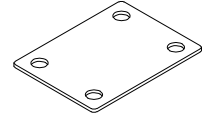

x 7

6

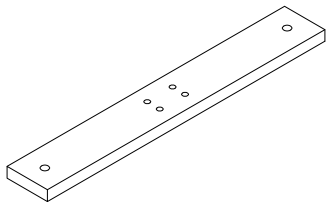

x 2

7

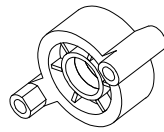

x 1

8

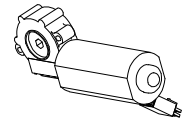

x 1

9

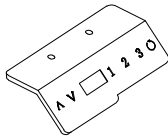

x 1

10

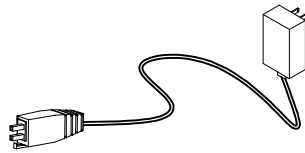

x 1

11

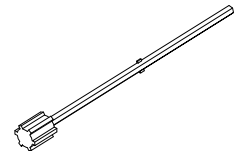

x 1

12

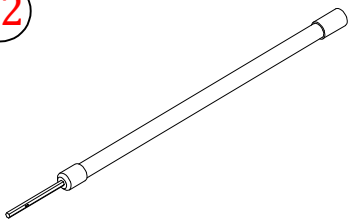

x 1

13

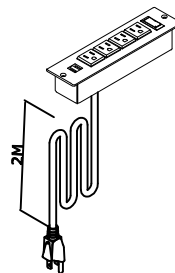

x 1

14

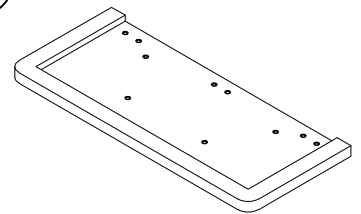

x 1

15

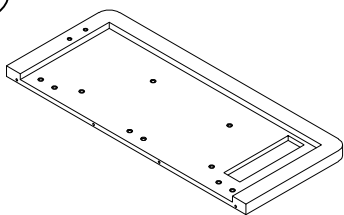

x 1

16

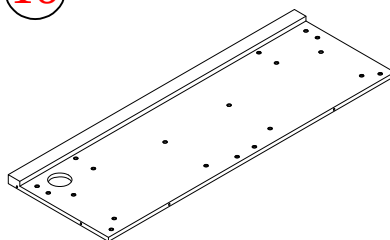

x 1

17

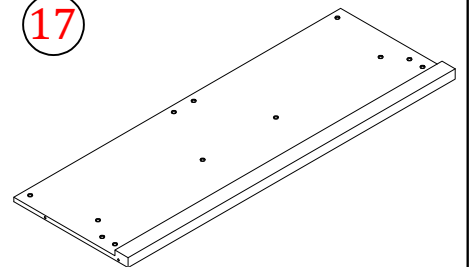

x 1

18

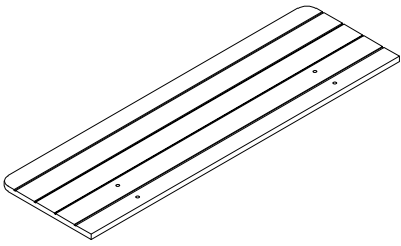

x 1

21

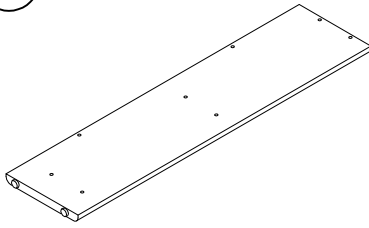

x 1

22

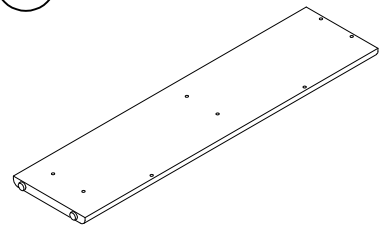

x 1

23

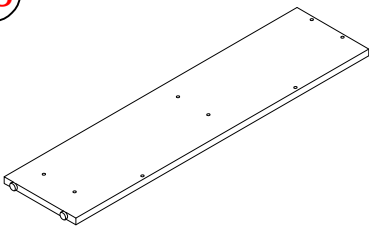

x 1

24

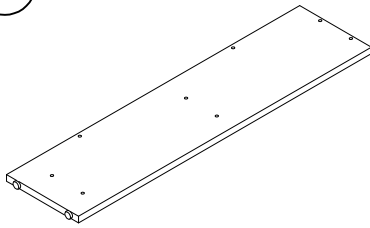

x 1

25

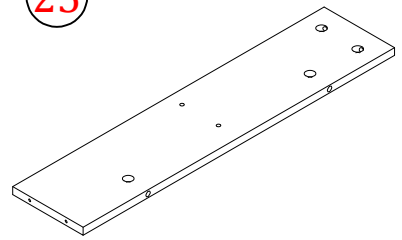

x 2

26

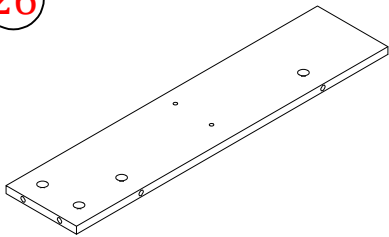

x 2

27

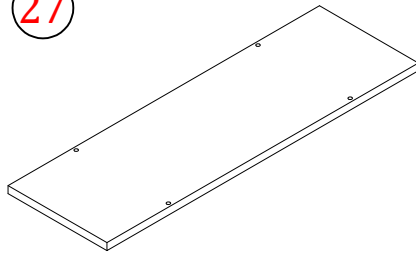

x 2

30

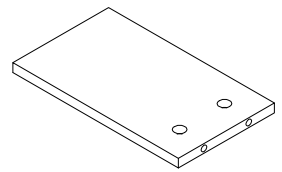

x 4

1

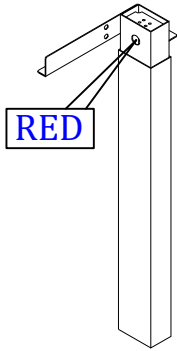

x 1

2

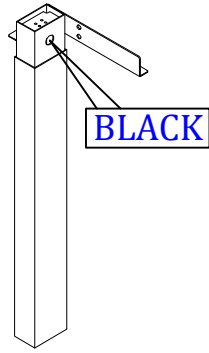

x 1

19

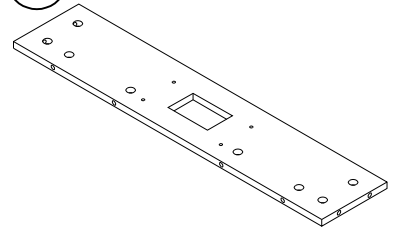

x 2

20

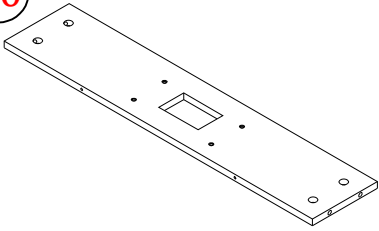

x 2

28

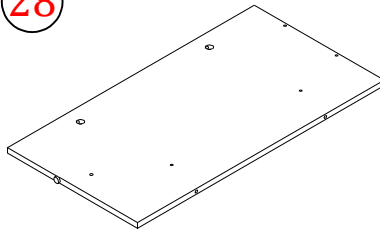





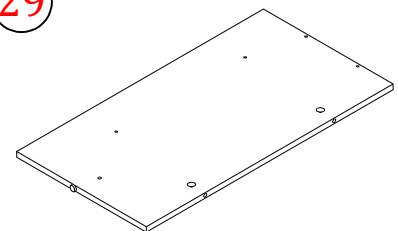









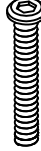











x 2

29

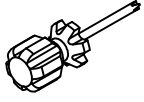
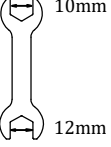
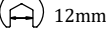
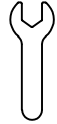

x 2

A M5x42  56 PCS	B Ø15x10  56 PCS	C M5x40  28 PCS	D Ø6x40  14 PCS	E M6x16  4 PCS	F M6x10  36 PCS	G M8x40  8 PCS
H M6x30  4 PCS	I M6x50  20 PCS	J M4x45  2 PCS	K M4  2 PCS	L 12*4*1  2 PCS	M 15*6*2  20 PCS	N M6xL12  4 PCS
O M5x10  2 PCS	P M3.5x12  2 PCS	Q  3 PCS	R Ø22x1  40 PCS	S Ø60  1 PCS	T M6x20  4 PCS	U M8xØ45  4 PCS
V L100*185  2 PCS	  1 PCS	 10mm  12mm 1 PCS	M4  1 PCS	4#   1 PCS	5#  1 PCS	

All the screws
are in "Package A"

Cam Lock Fastening System

This Cam Lock Fastening System will be used throughout the assembly process

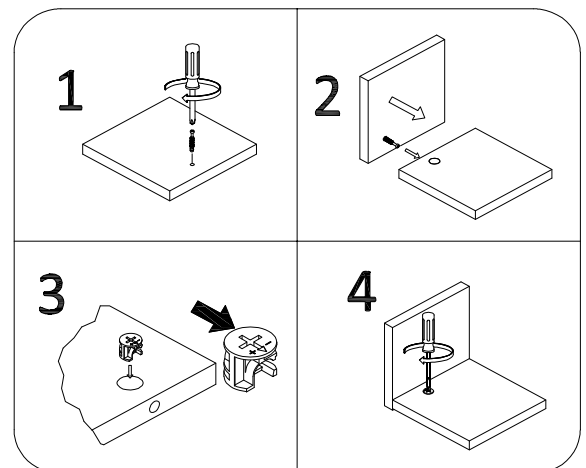
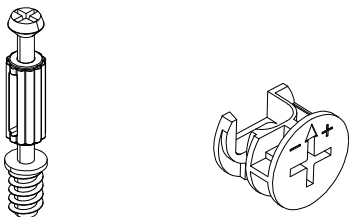

C M5x40



8 PCS

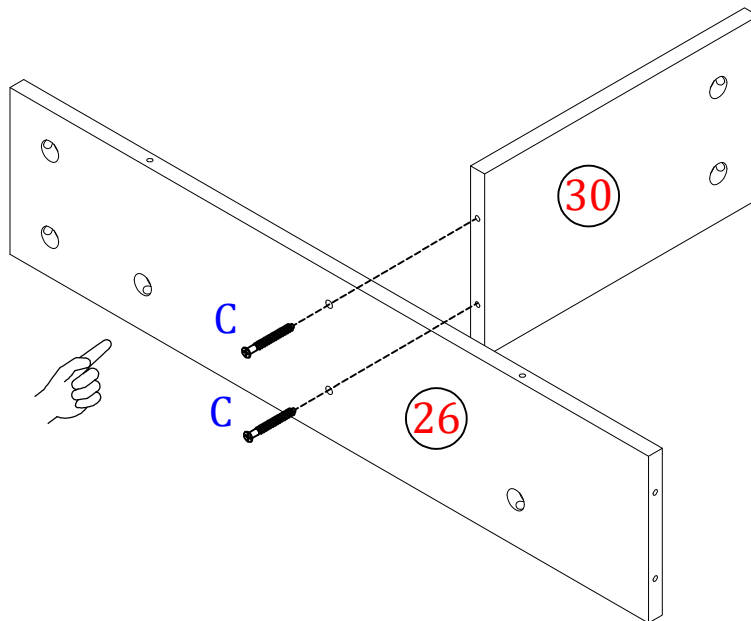
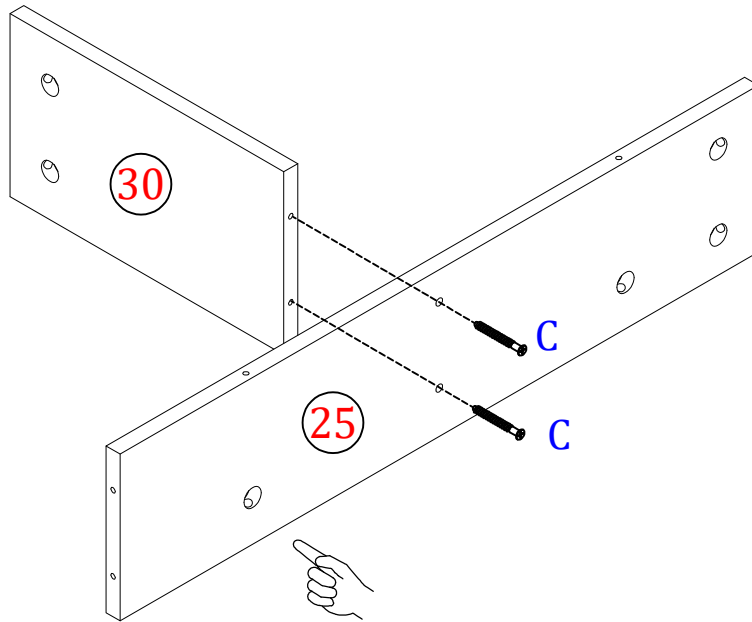

X 2

A M5x42



8 PCS



B Ø15x10

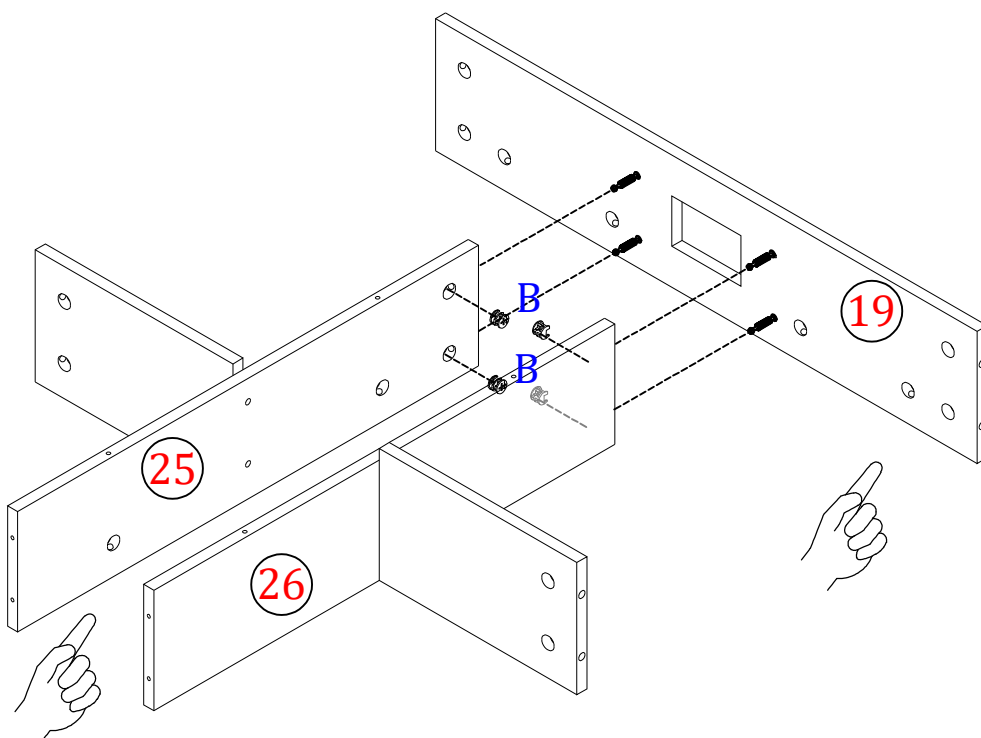
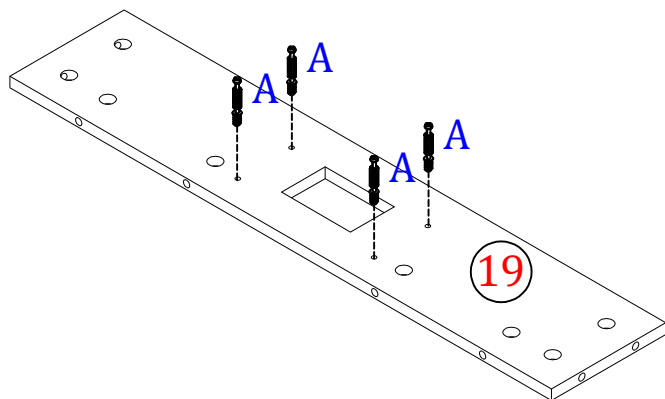

8 PCS



X 2

A M5x42	D Ø6x40
	
16 PCS	4 PCS

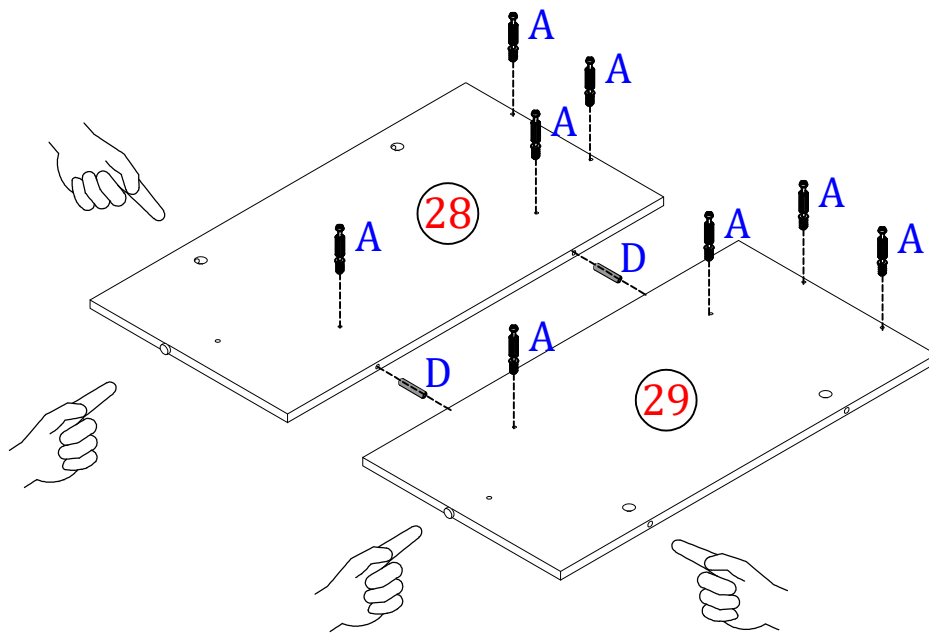

X 2

B Ø15x10

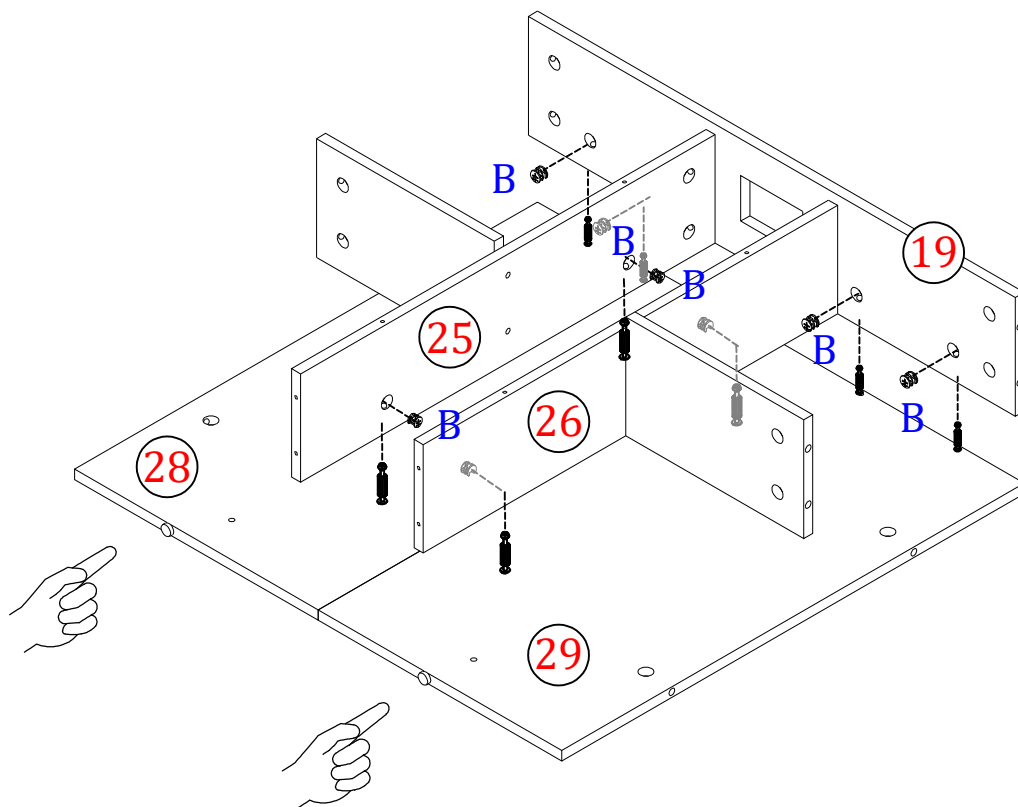
16 PCS

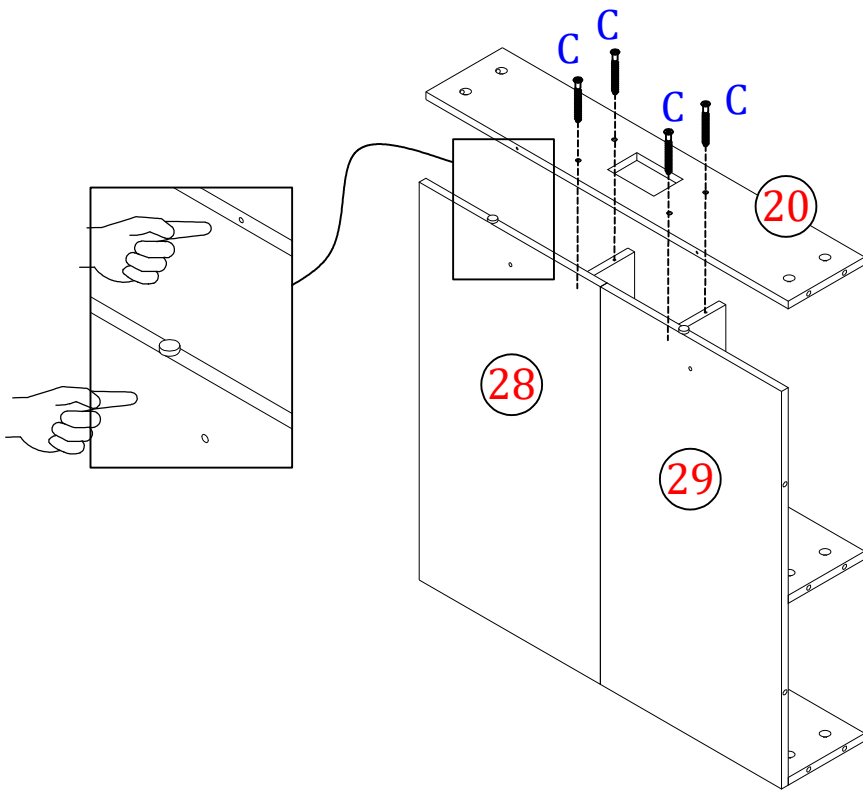

X 2



C M5x40



8 PCS



Pay attention to the direction.

X 2

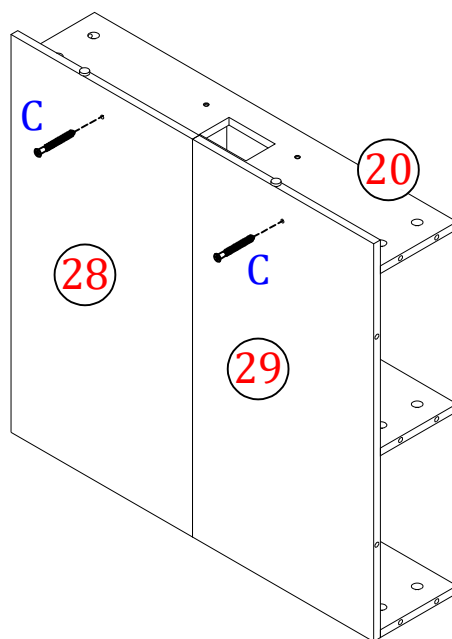

C M5x40



4 PCS

X 2

A M5x42



16 PCS

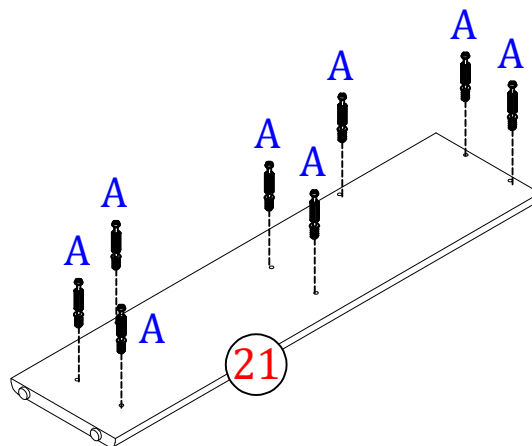
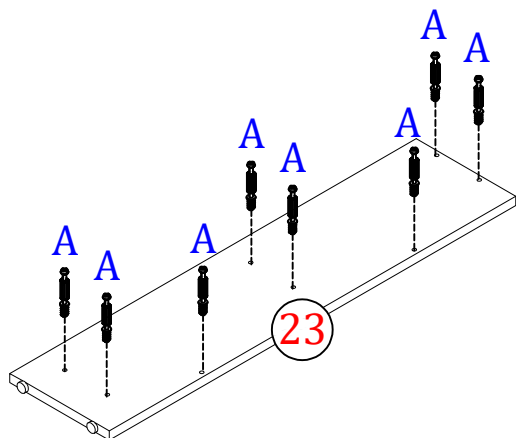

B Ø15x10



16 PCS



Pay attention to the direction.

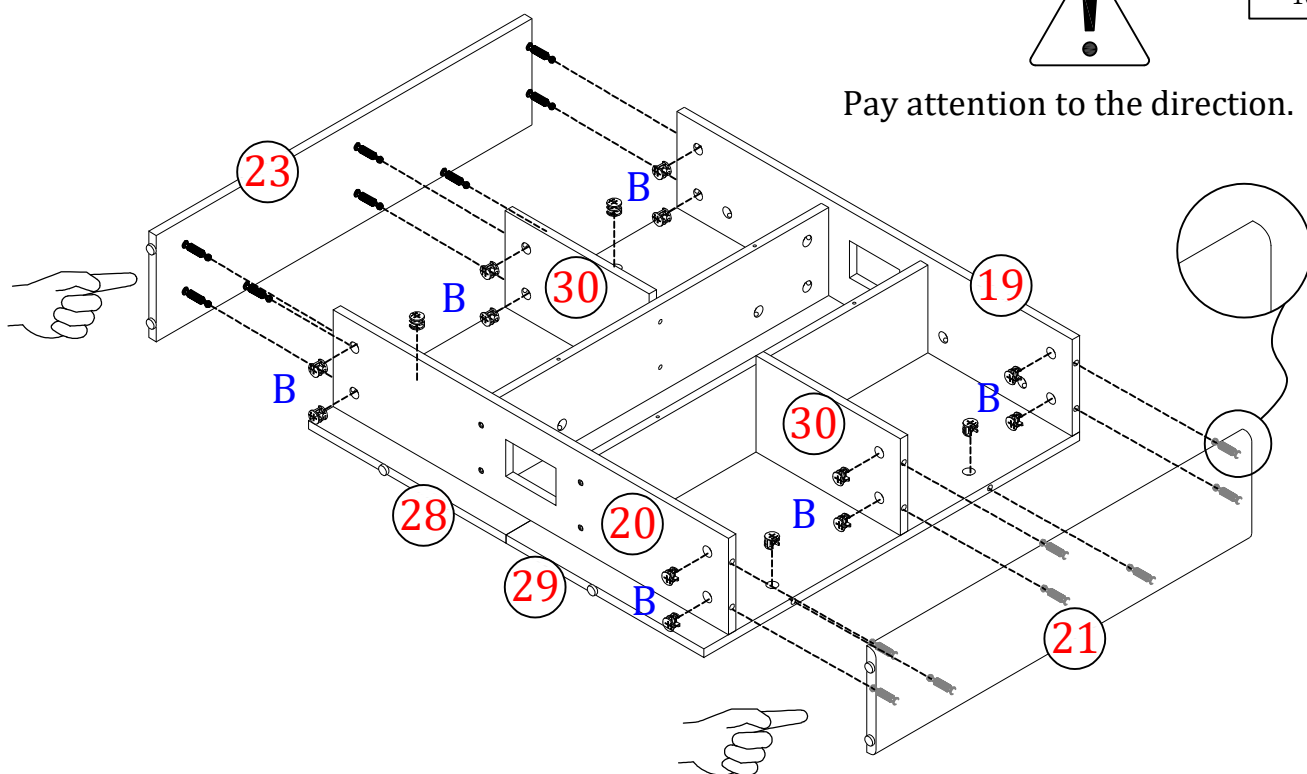

A M5x42



16 PCS

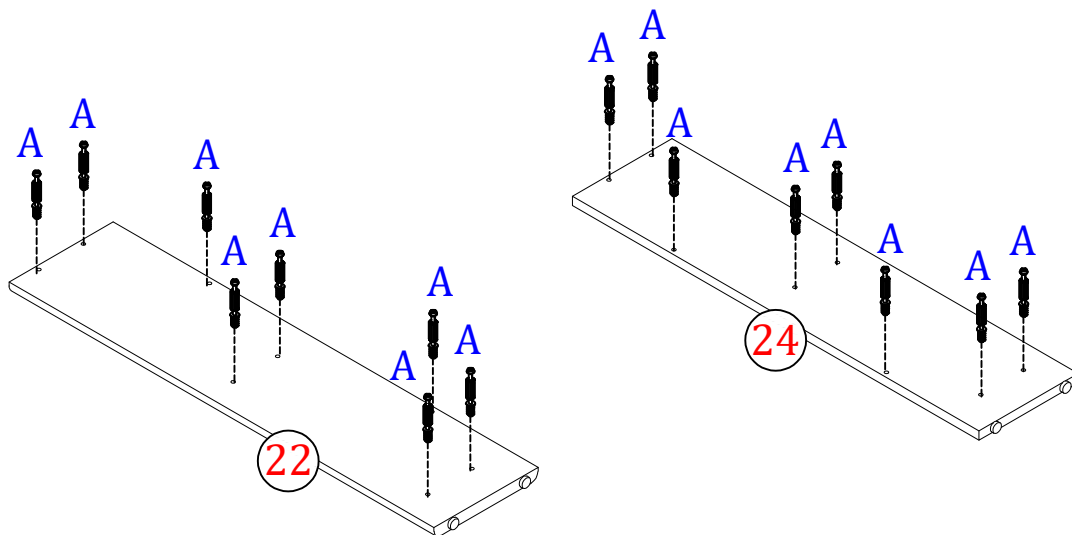

Pay attention to the direction.

B Ø15x10



16 PCS

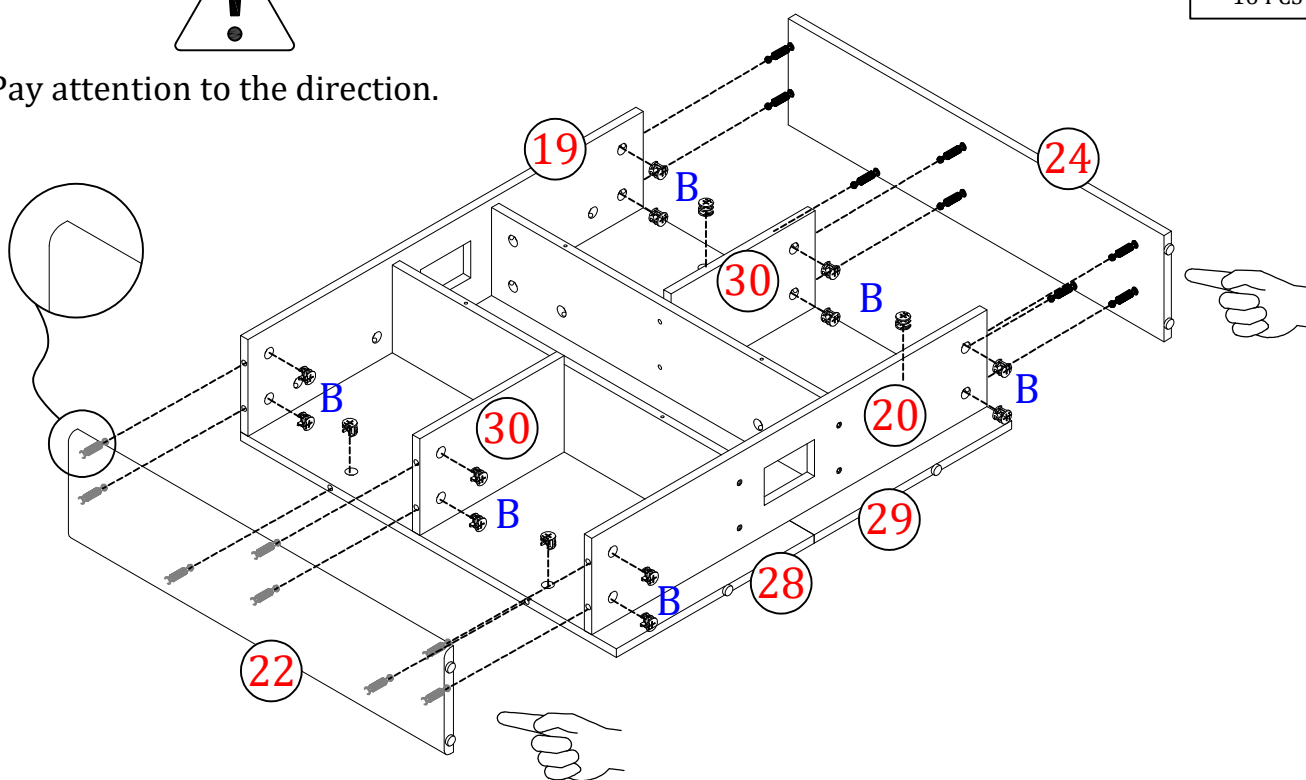

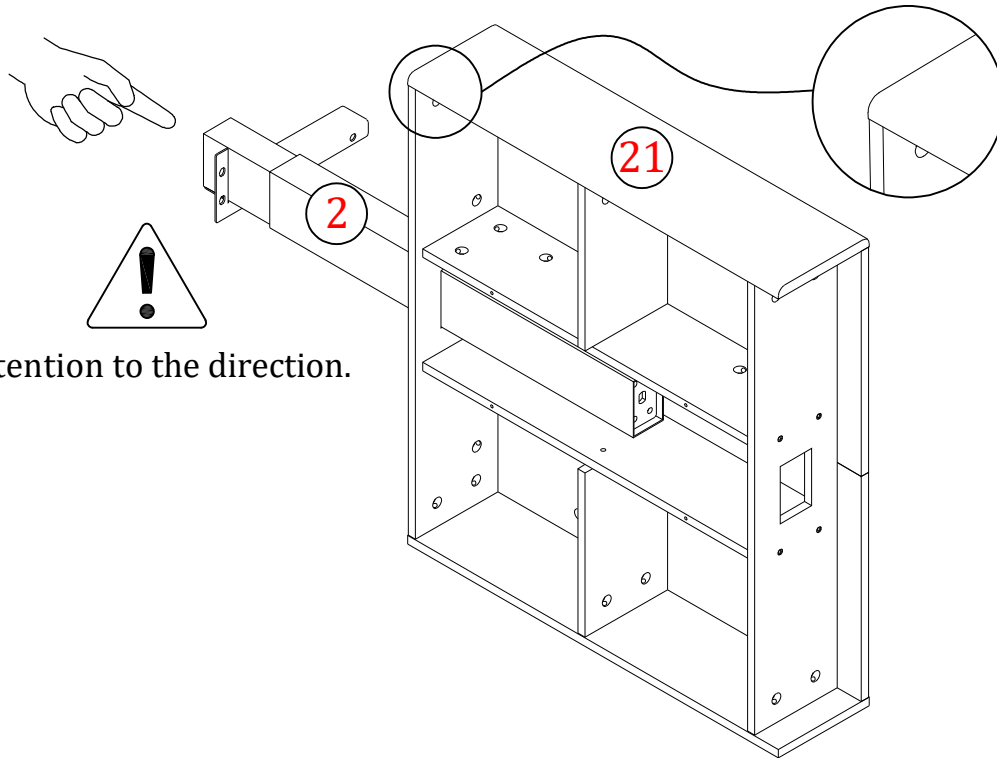

Pay attention to the direction.

G M8x40

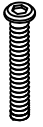

4 PCS

U M8xØ45



2 PCS

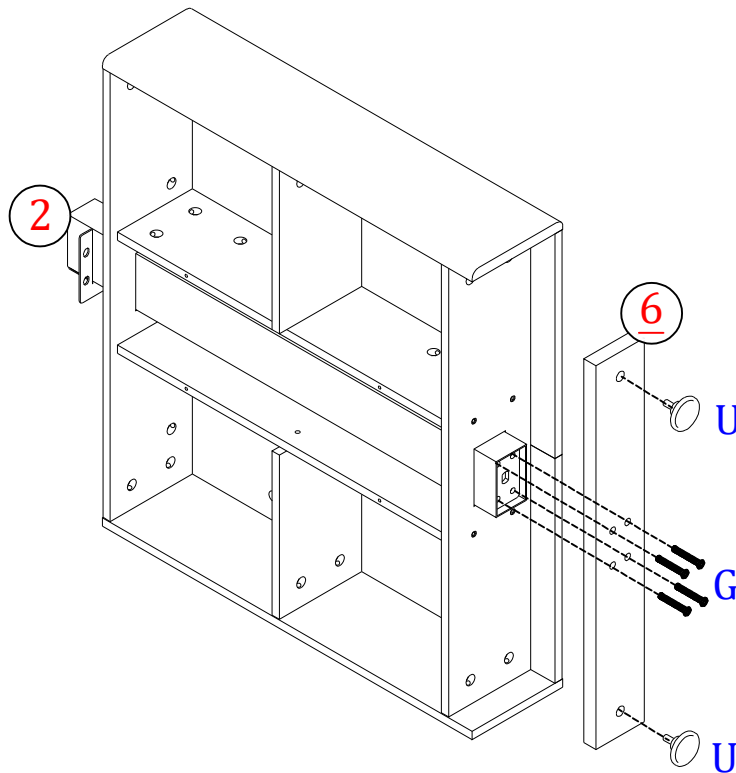

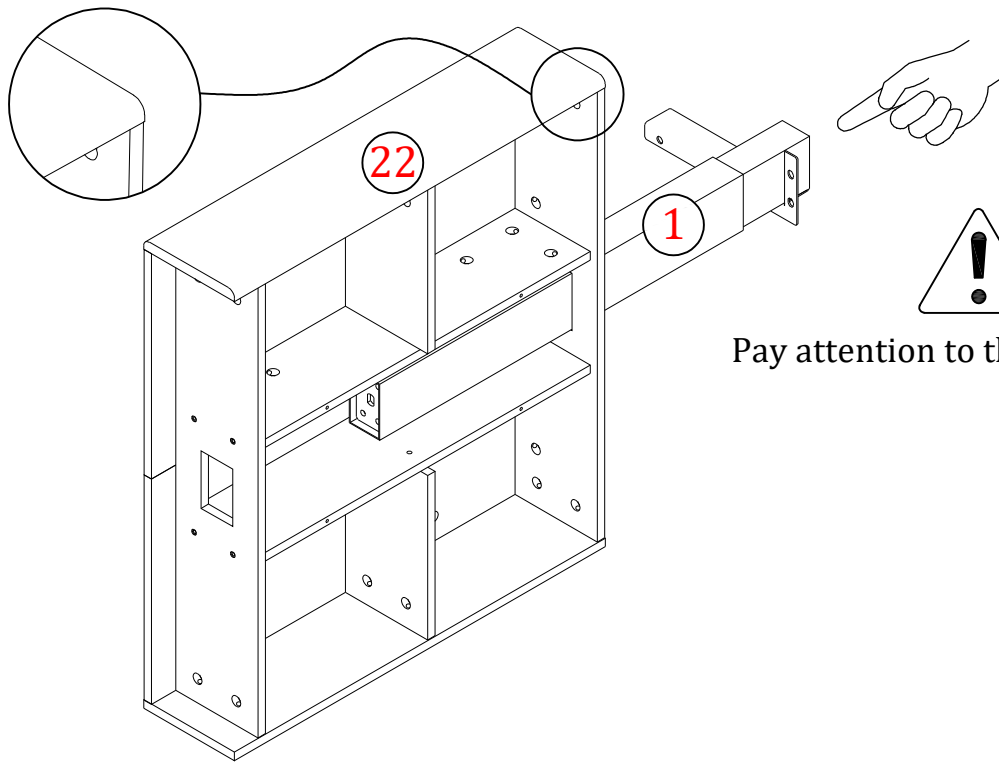

G M8x40

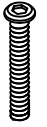

4 PCS

U M8xØ45



2 PCS

Pay attention to the direction.

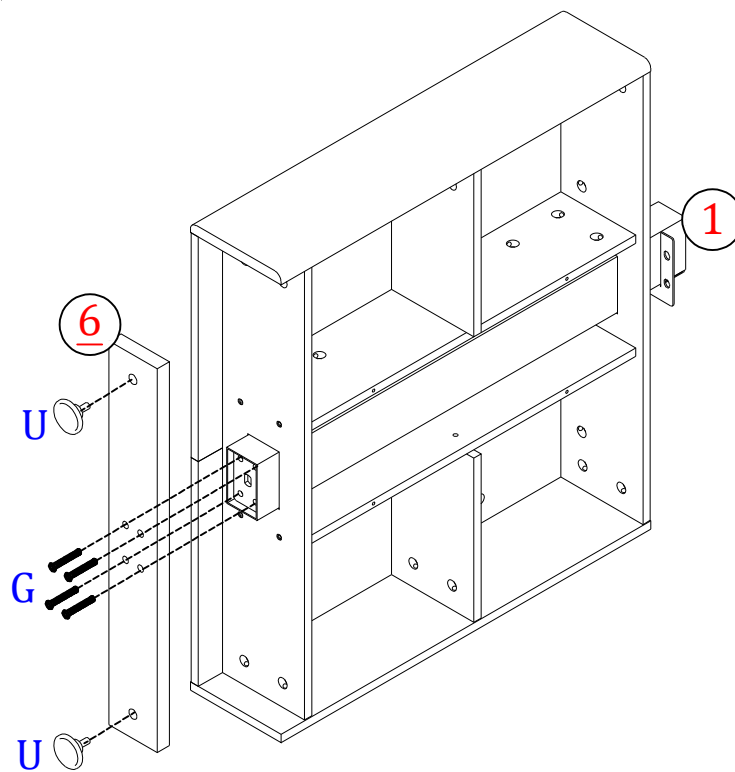

C M5x40



8 PCS

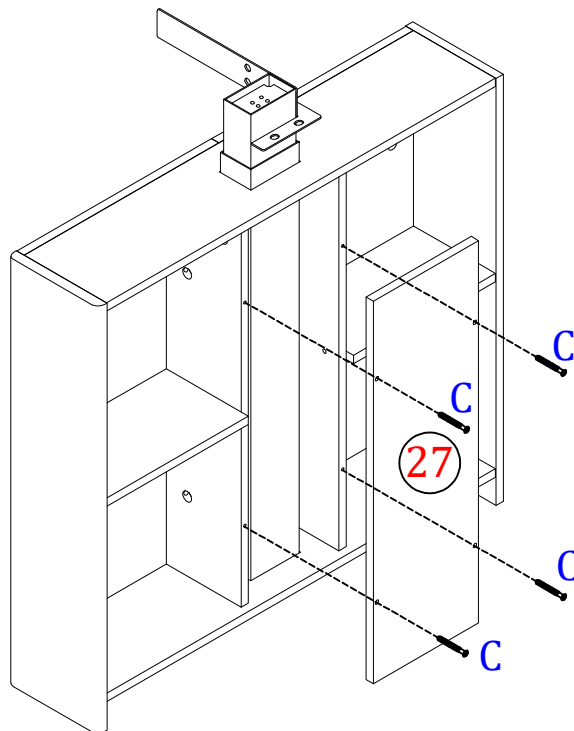
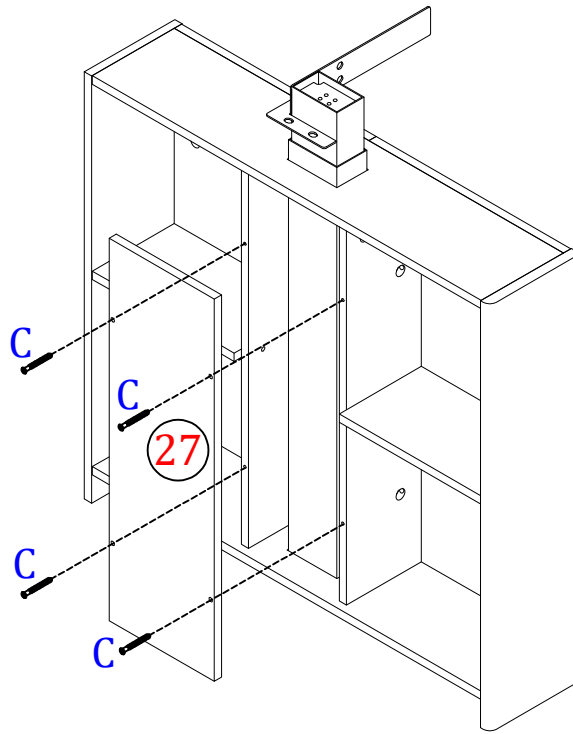

H M6x30



2 PCS

N M6xL12





2 PCS

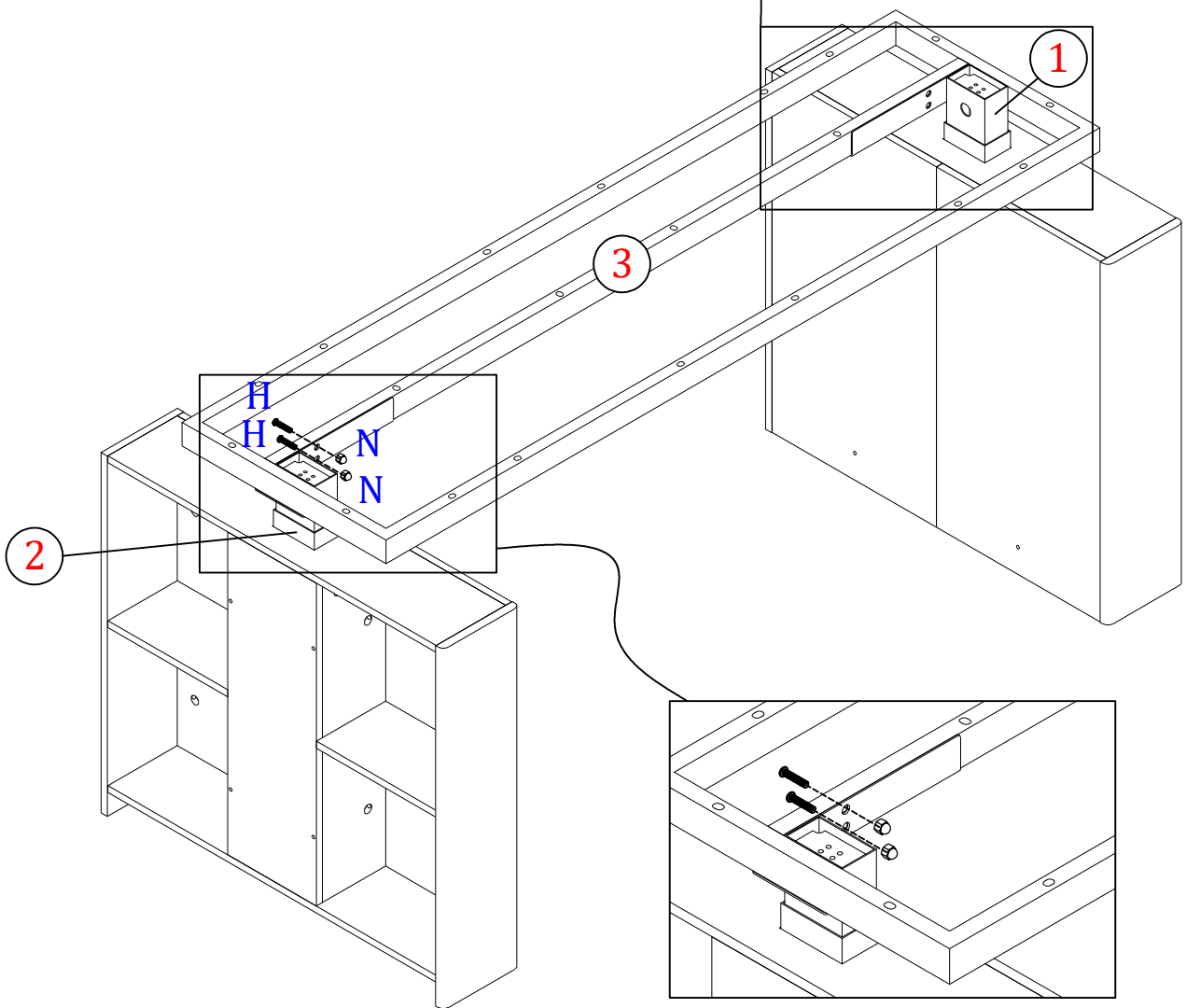
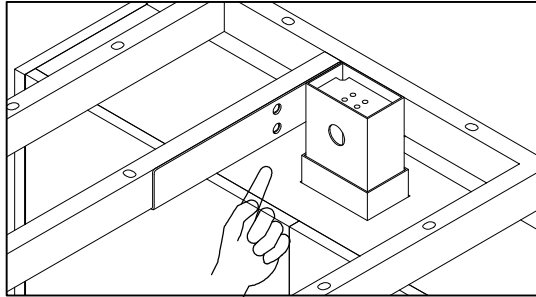

Pay attention to the direction.



J M4x45	K M4	L 12*4*1
		
2 PCS	2 PCS	2 PCS

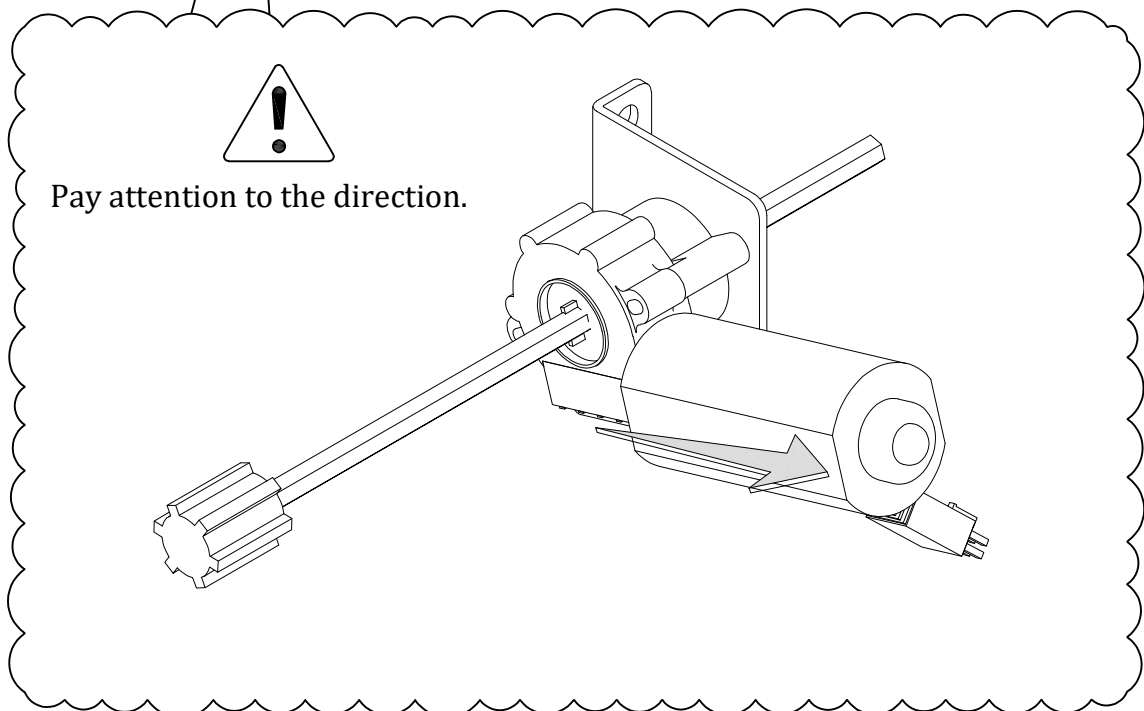
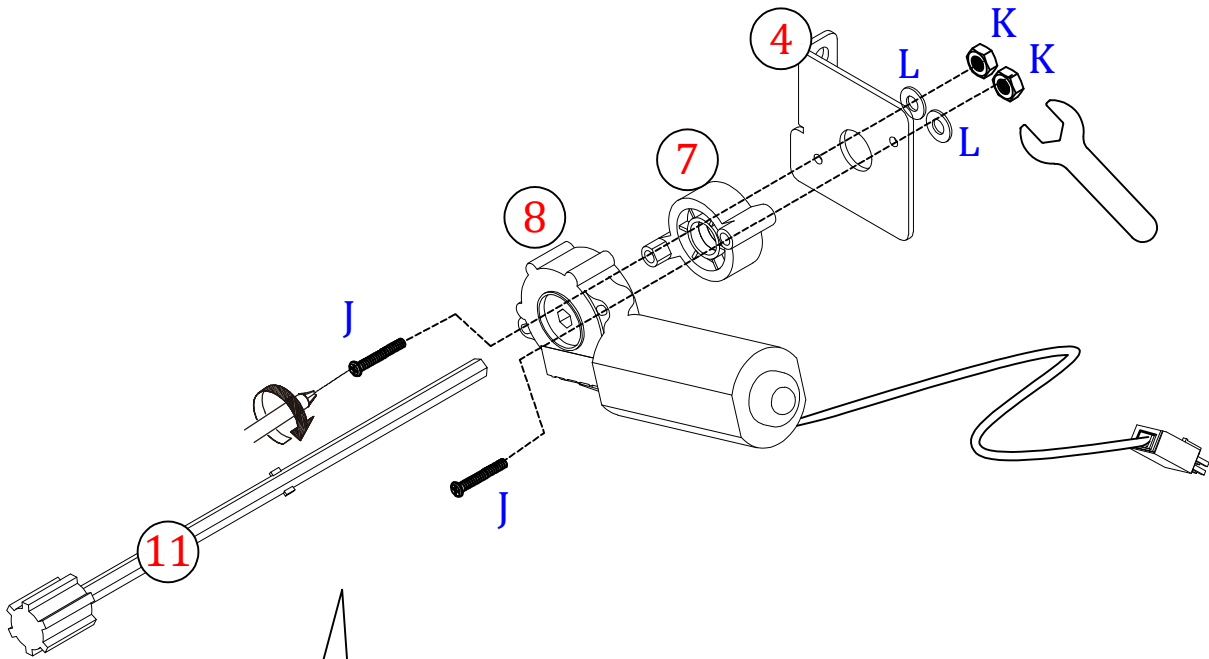

H M6x30



2 PCS

N M6xL12



2 PCS

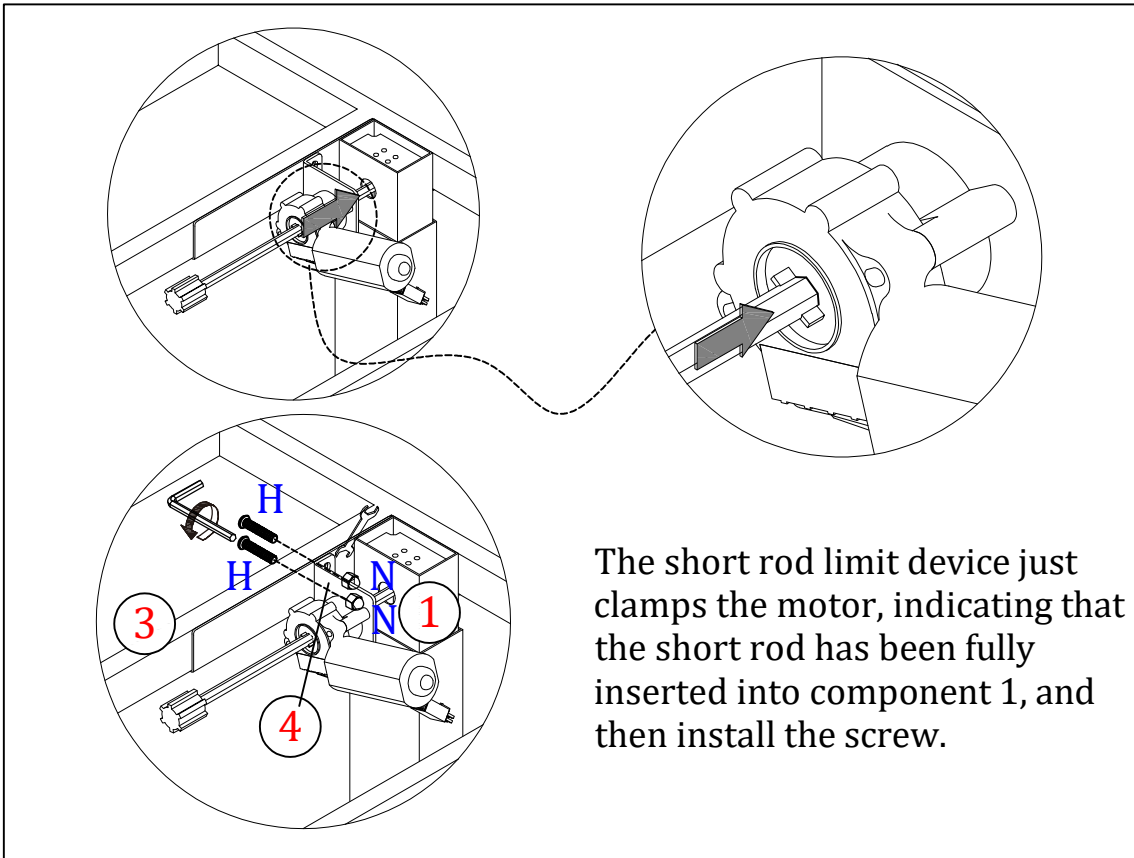

The short rod limit device just clamps the motor, indicating that the short rod has been fully inserted into component 1, and then install the screw.

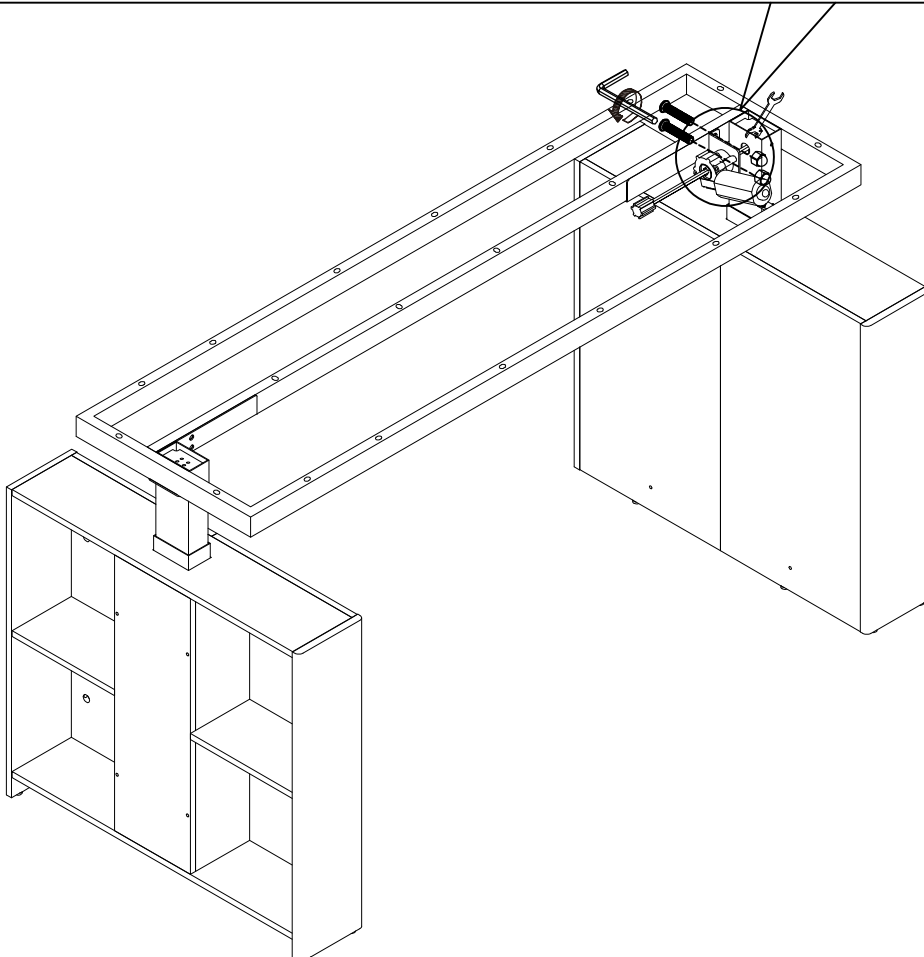

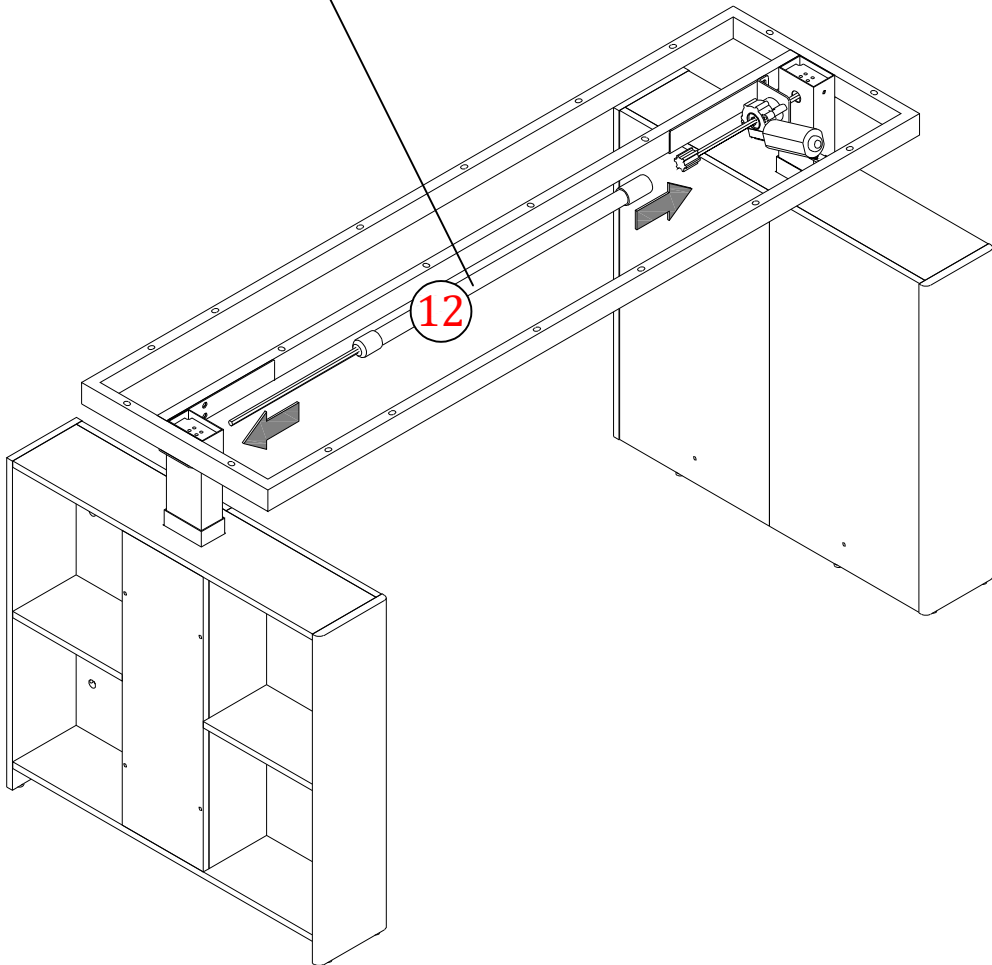
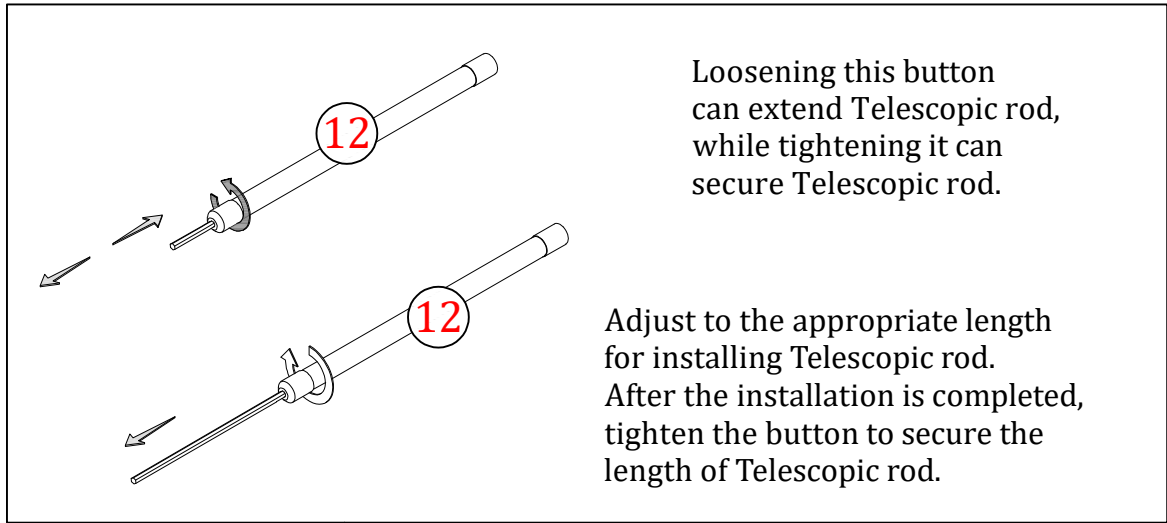

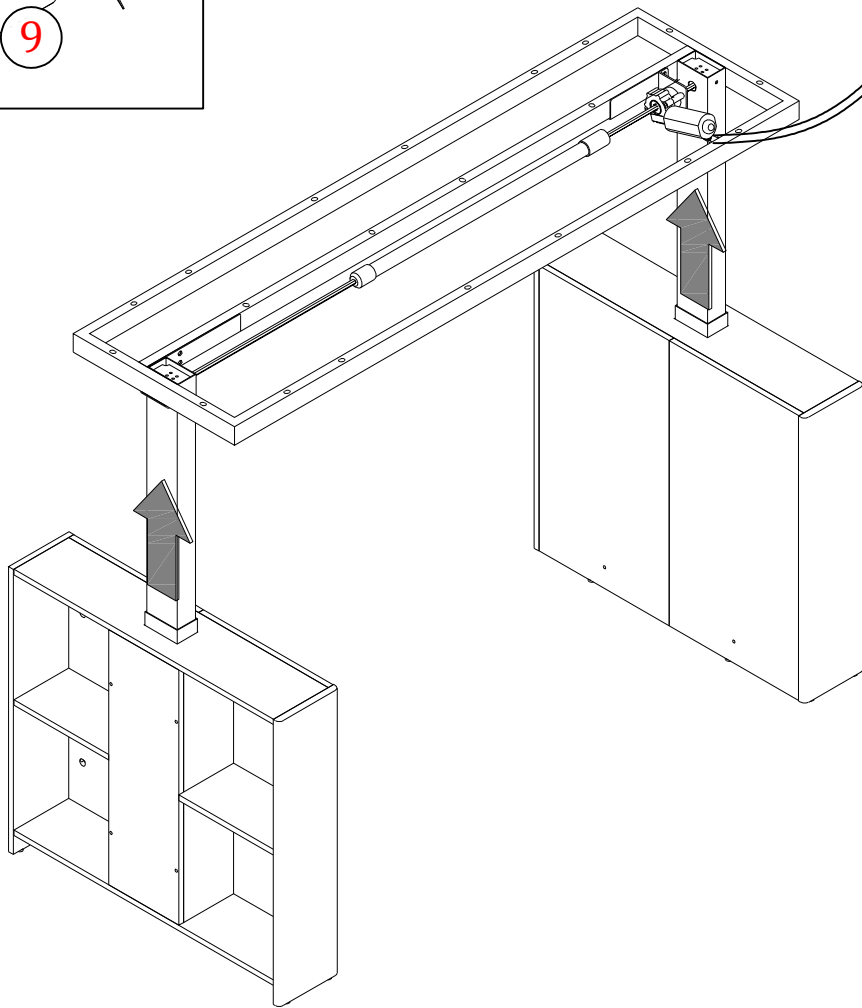
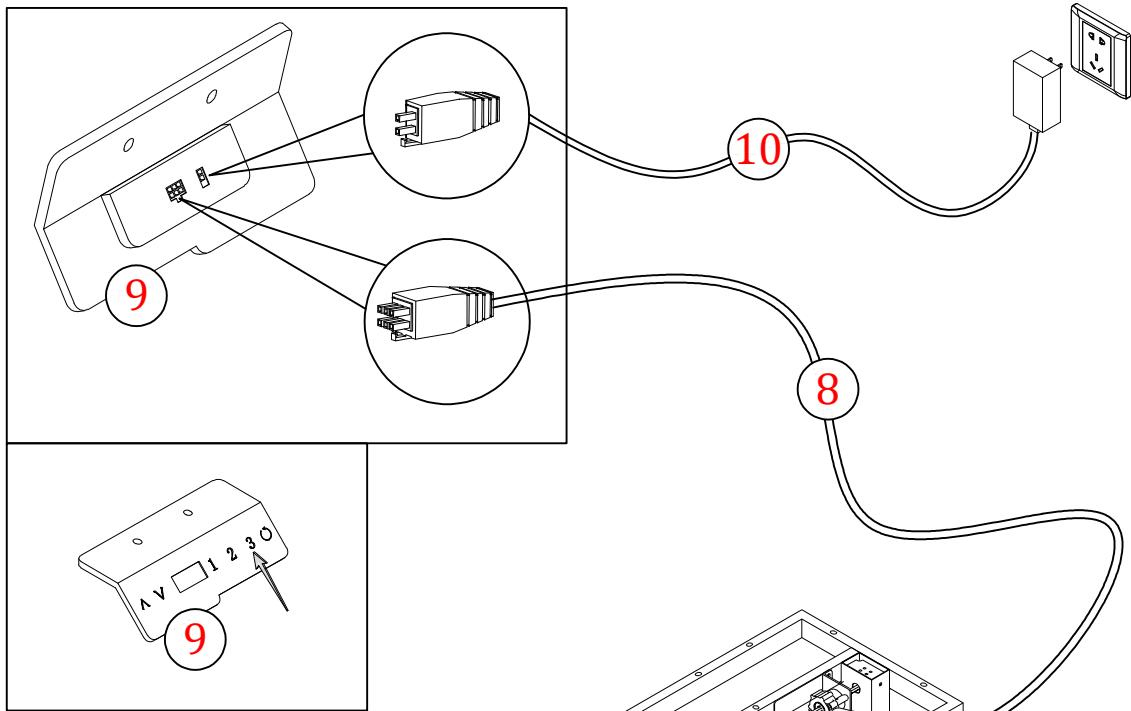

F M6x10



8 PCS

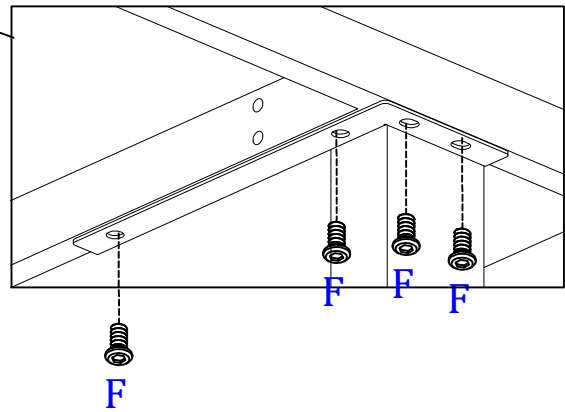
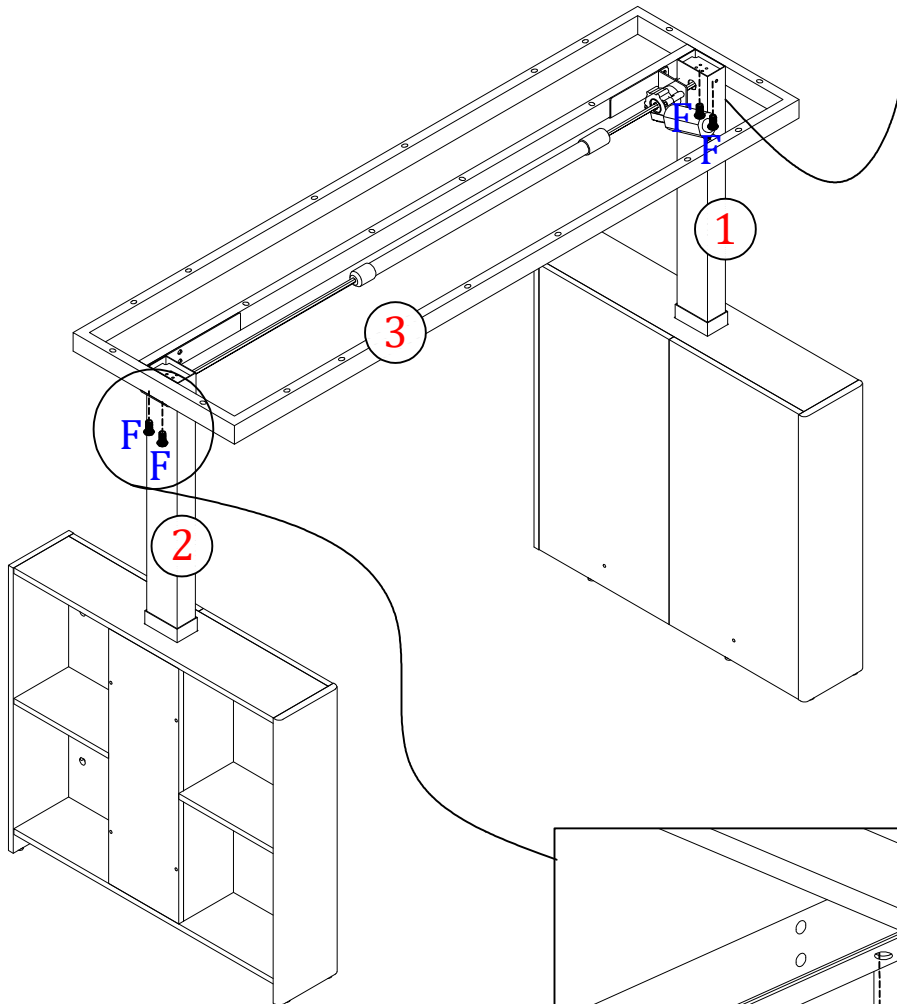
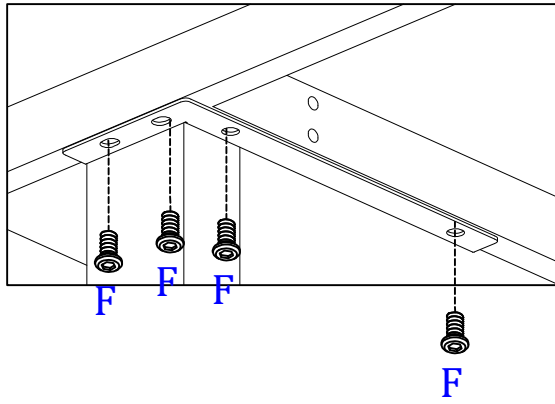

D Ø6x40



10 PCS

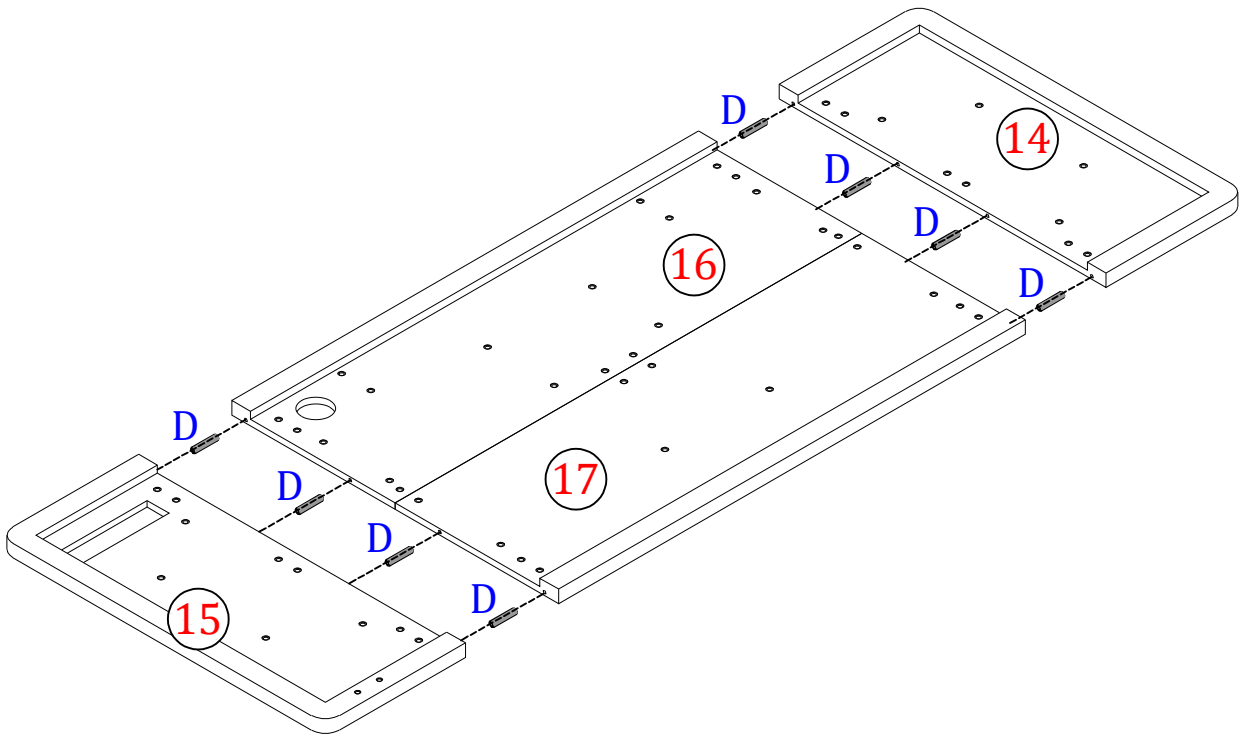
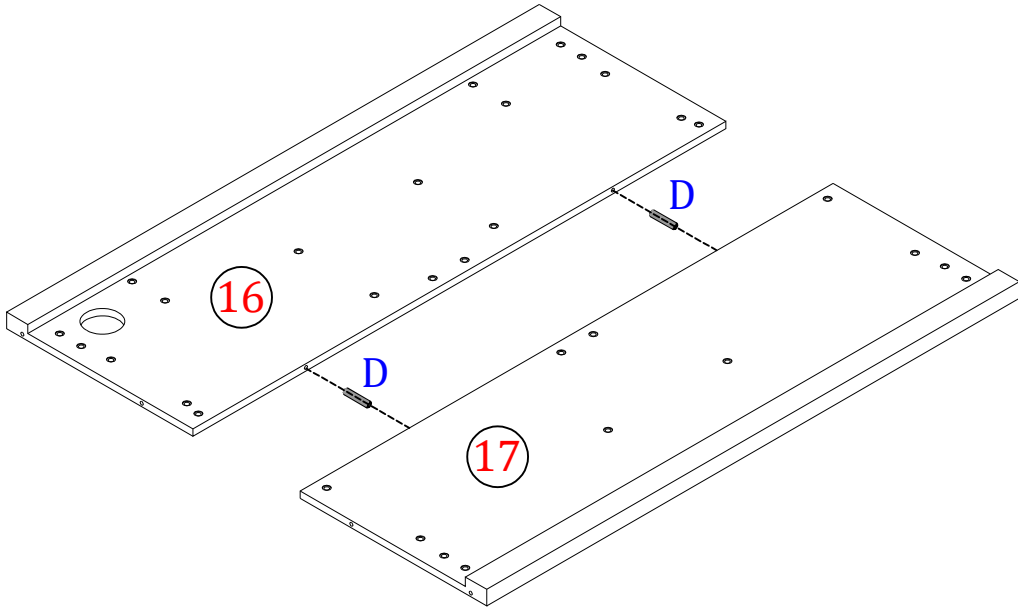

F M6x10



28 PCS

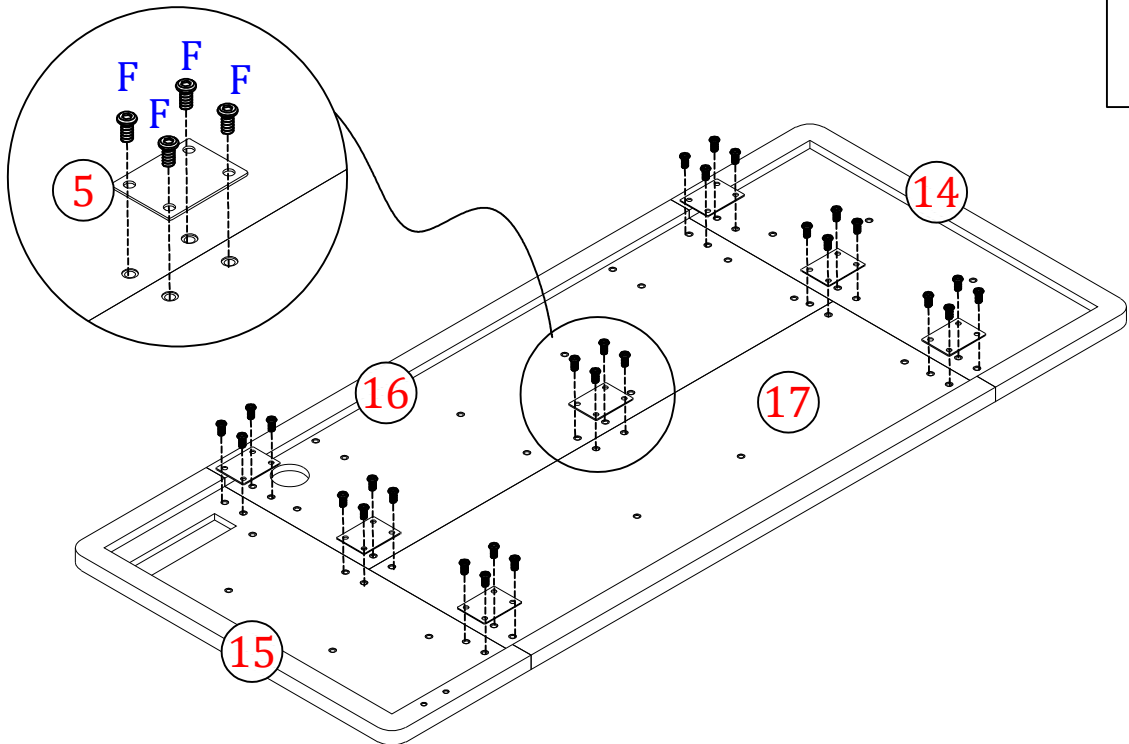

V L100*185

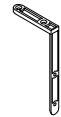

2 PCS

E M6x16



4 PCS

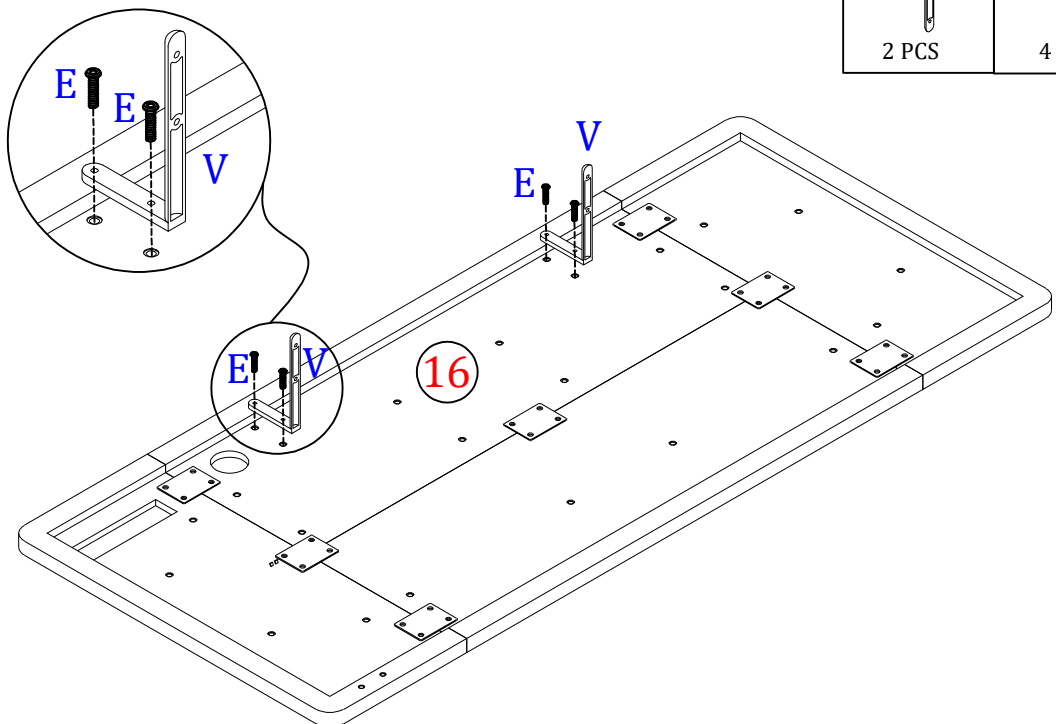

I M6x50

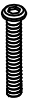

20 PCS

M 15*6*2



20 PCS

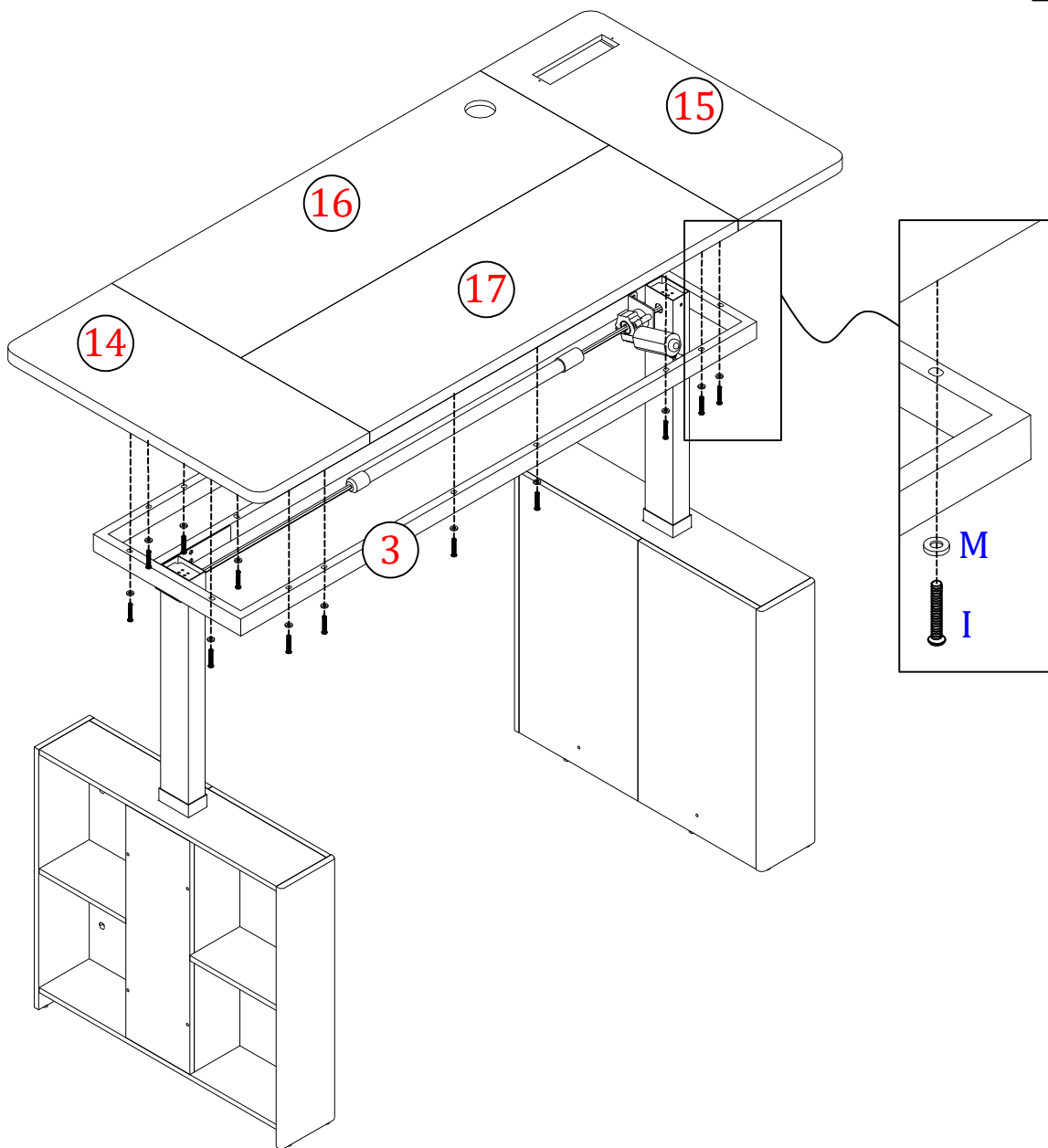



T M6x20



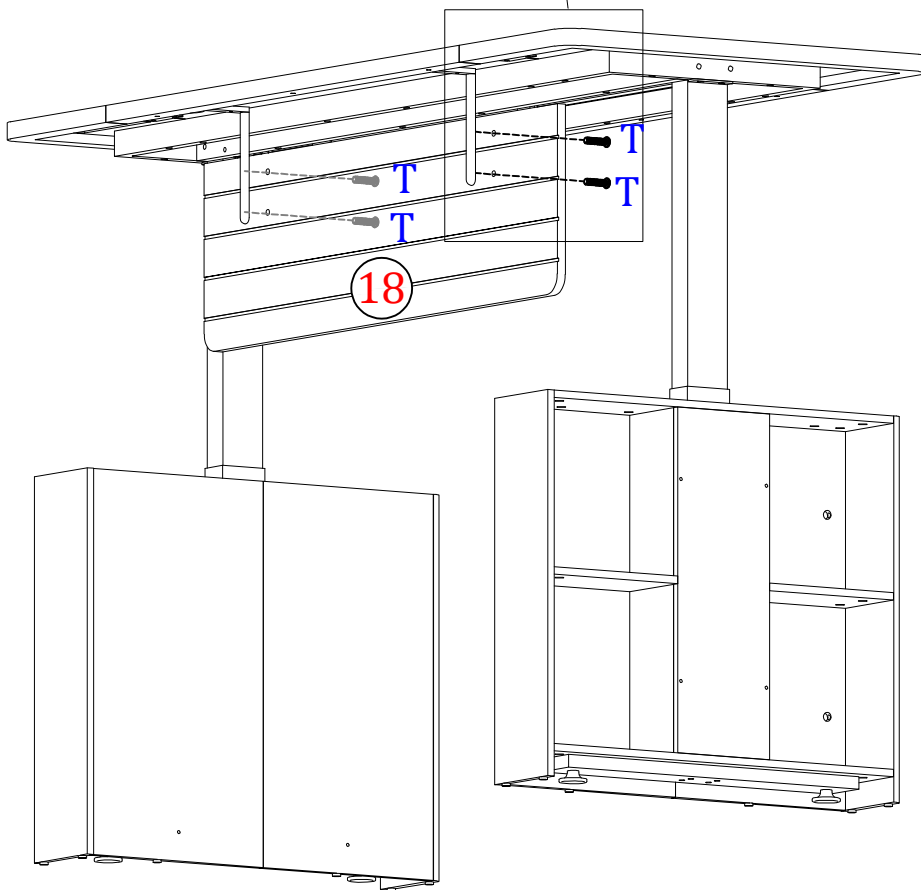
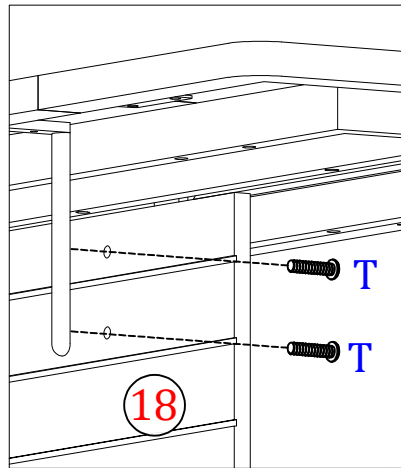

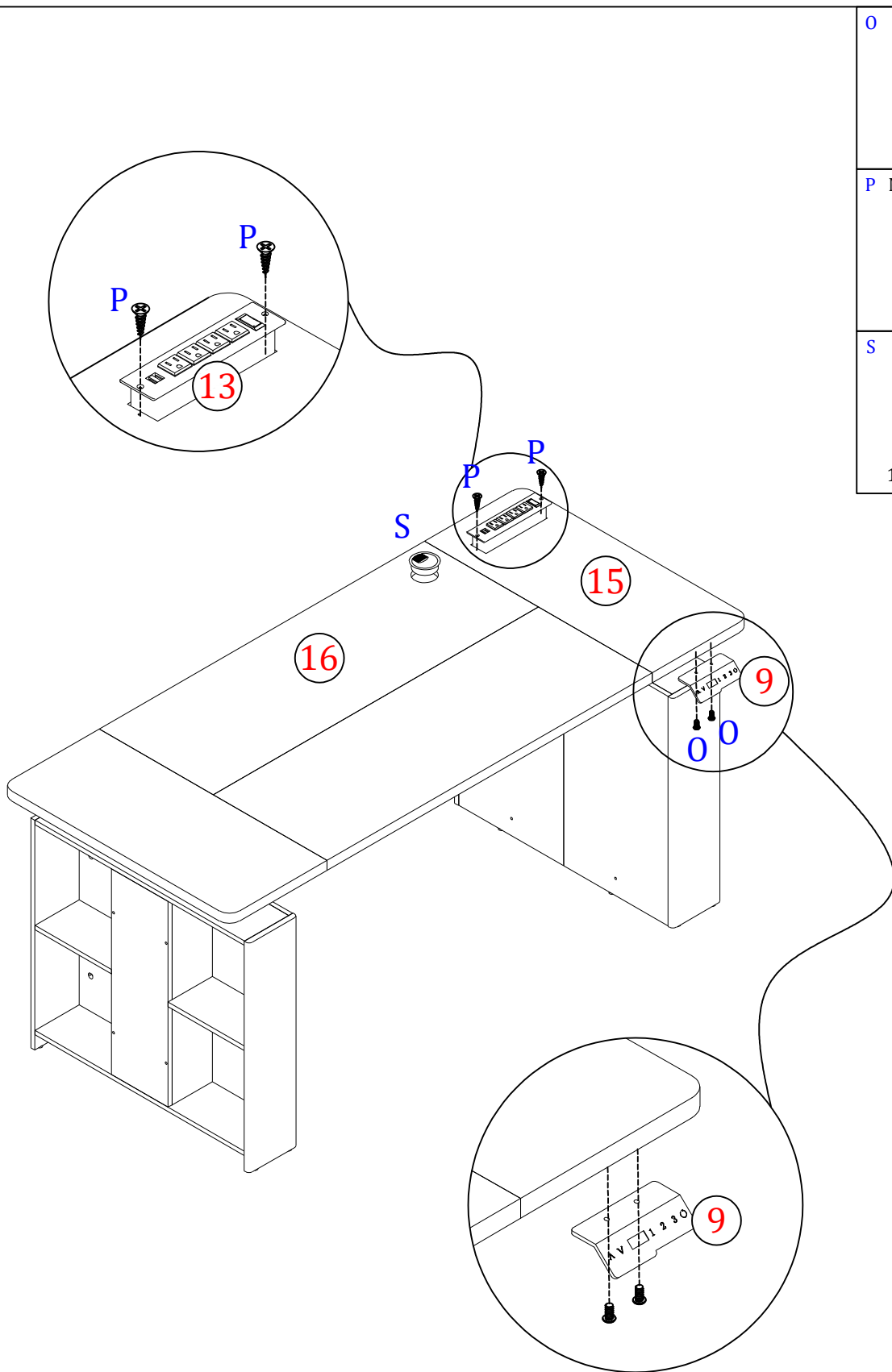
4 PCS



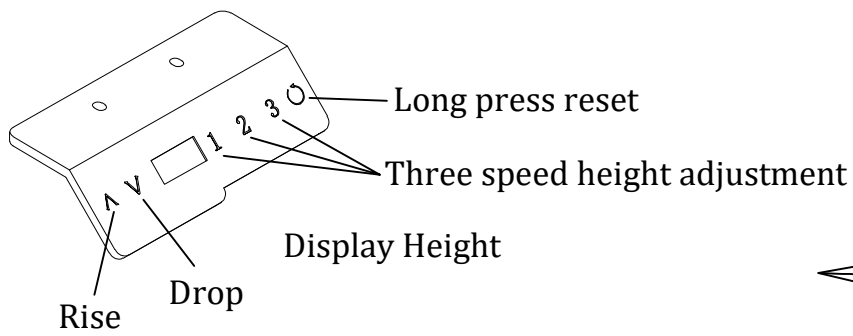

O	M5x10
	
	2 PCS
P	M3.5x12
	
	2 PCS
S	Ø60
	
	1 PCS



- Q**  3 PCS
- R**  Ø22x1 40 PCS

Please refer to the detailed instruction manual for specific details.

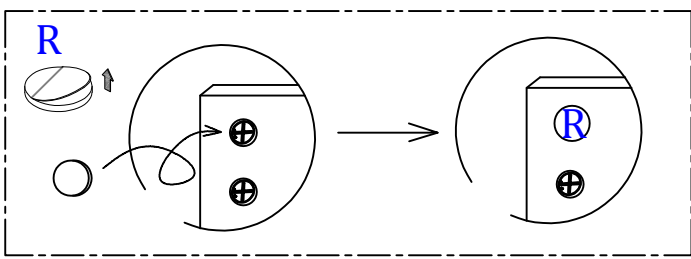
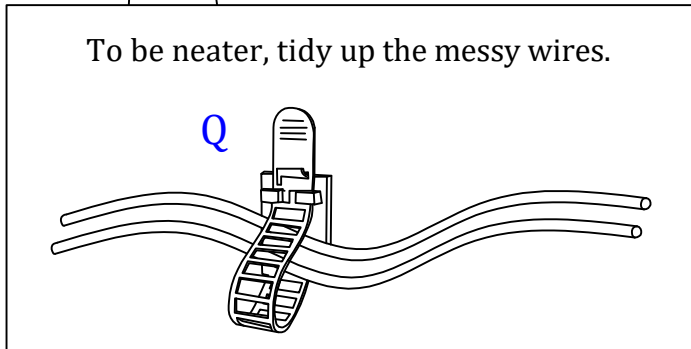
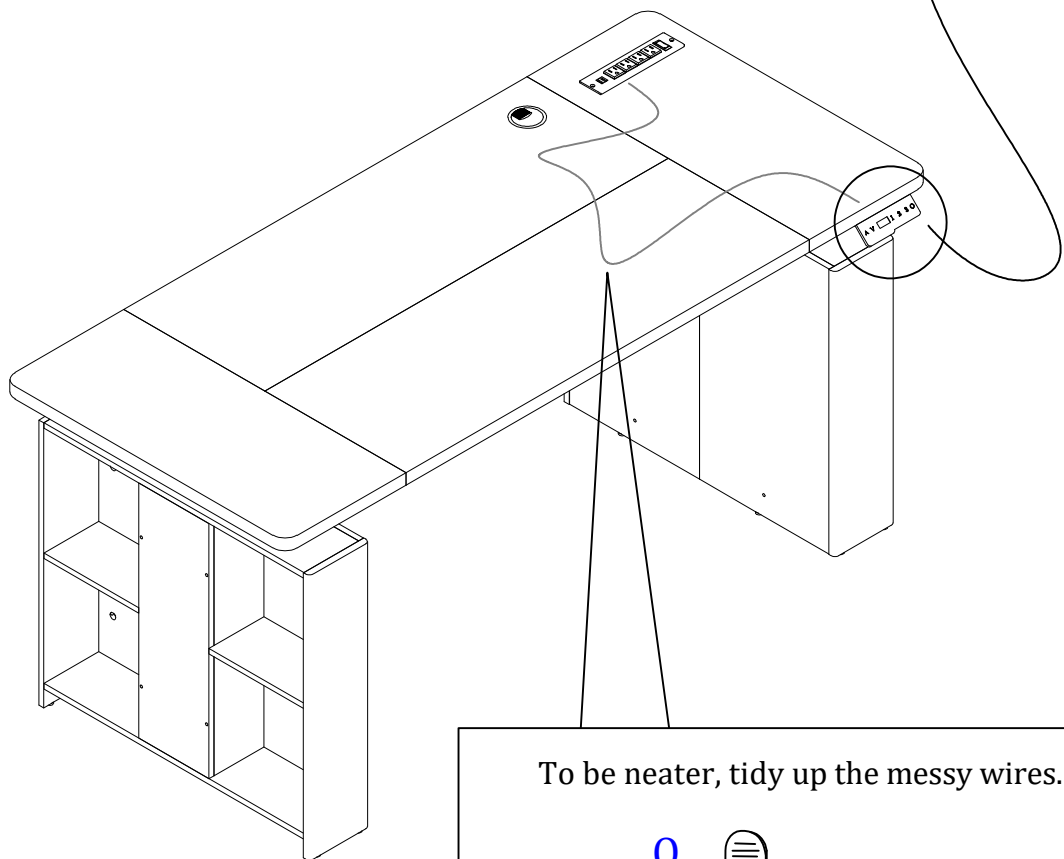

Motor Lift Table Instruction Manual

Hand controller interface introduction

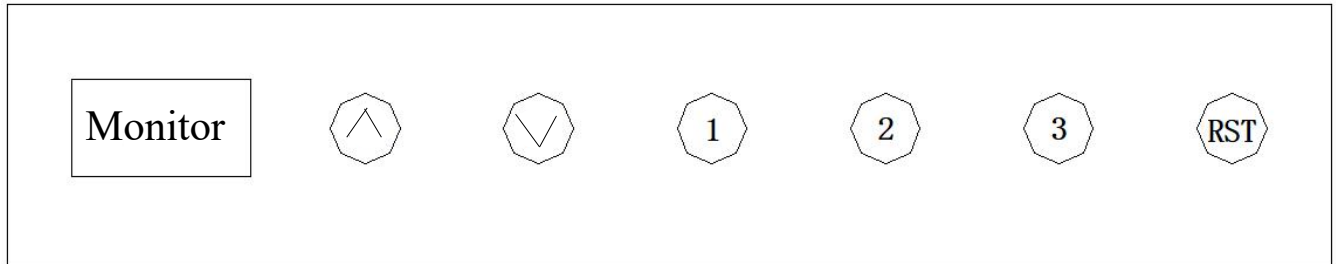

- ◆ monitor
- ◆ UP: up key
- ◆ DOWN: down key
- ◆ 1: (save key) 1
- ◆ 2: (save key) 2
- ◆ 3: (save key) 3
- ◆ RST: reset

Up and down key operation

- ◆ When the "up" key is pressed, desktop run up, until the top of the table is reached
- ◆ When the "Down" key is pressed, desktop run down, until the lowest point of the table is reached
- ◆ When short press the "up" or "down" key, The desktop runs a small distance accordingly, Realize jog

location storage/memory position operation

◆ location storage: Can store 3 memory points, The storage method is as follows, when running to a certain point, At this time, long press the "1 / 2 / 3" button, until the digital number flashes, Save the current altitude to the corresponding label successfully.

◆ memory position operation: Short press "1 / 2 / 3" key, Digital tube flashing memory position height 2S, The desktop automatically runs to the height of the memory position, running, Any key can stop the operation.

Zero position reset

◆ **After the installation is completed, if the displayed height does not match the actual height, you can perform the following operations.**

◆ Long press "RST" for 3S and wait for the controller running indicator to flash "- - -", Then release the down button to enter the reset mode, The desktop automatically runs down and then up to find the highest and lowest positions, After the end, the desktop will automatically run down to a fixed position, end of reset process.

automatic testing(Do not proactively disclose to end users)

- ◆ The system supports automatic operation, Run time is fixed at 2 minutes, The stop time is determined by the e parameter, Infinite loop. (Please refer to the internal parameter setting and description for stop time.)
- ◆ Enter: Press and hold the "Up" + "Down" + "RST" buttons at the same time for 5 seconds, Nixie tube shows Aot, Indicates automatic test mode.
- ◆ Quit: Press and hold the "Up" + "Down" + "RST" buttons at the same time for 5 seconds, Digital tube display height, Indicates to exit the automatic test mode.

Minimum limit setting

◆The system supports the minimum height of the desktop, The operation method is, Let the desktop run to the position you want to set, Press and hold the "RST" + "Down" buttons at the same time for 5 seconds, Displaying "-d o" indicates that the lowest position is successfully stored, when running to the lowest point, Display shows "-L o".

◆Cancel storage height, method 1: Mechanical zero reset, The system automatically cancels

Method 2: Let the desktop run to the lowest point, Display shows "-L o", Press and hold the "RST" + "Down" buttons at the same time for 5 seconds, "--d o" indicates successful cancellation.

Maximum limit setting

◆The system supports the maximum height of the desktop, The operation method is, Let the desktop run to the position you want to set, Press and hold the "RST" + "Up" buttons at the same time for 5 seconds, - u p indicates that the highest position is successfully stored. when running to a high point, Display shows "-HI"

◆Cancel storage height method 1: Mechanical zero reset, The system automatically cancels

Method 2: Let the desktop run to the highest point, Display shows "-HI"; Press and hold the "RST" + "Up" buttons at the same time for 5 seconds, "--up" indicates successful cancellation.

lock and unlock

◆locking:Press and hold "1" + "2" simultaneously for 5 seconds, when the digital tube displays "L",At this point, the system is locked, Unable to lift and lower the system.

◆Unlock: Press and hold "1" + "2" simultaneously for 5 seconds, When the digital tube displays from "L" to normal digital display, Indicates that the system has been unlocked.

Stand and sit reminder (countdown)

◆countdown time: 3 gears available, T30 = 30 minutes, T45 = 45 minutes, T60 = 60 minutes.

◆ Start the countdown:Short press "RST", the display will display T30/T45/T60 in sequence, Countdown time starts.

◆Exit countdown:1. Short press "RST", The display shows numbers;

2. The countdown time is up,The display will flash chr,Flashing time is 1 minute,Press any key to stop timing and exit.

3. 3. No operation,It will automatically exit the timer after 3 consecutive reminders at an interval of 5 minutes.

Restore factory default parameters

◆method:Press and hold "1" + "3" at the same time for 5 seconds, The digital tube displays "C L r",At this point, it indicates that the parameter recovery is successful.

Internal parameter settings and descriptions

◆Press and hold the "RST+1" button on the hand controller for 10 seconds, You can enter the setting interface,Displays "x-y" while "x" flashes,Where "x" is the parameter group,The parameter value corresponding to "y".At this time, press "RST" to switch the parameter group,Press "Up" or "Down" to correspond to the value of the parameter.After setting the parameters, press and hold the "RST" key for 10 seconds,Return to the running interface,The set parameters are as follows:

Display content	Number range	Setting parameters	illustrate
a-y	0-1	Display format	0 means metric display, 1 means inch display;
b-y	1-2	Number of pole pairs	1 means 1 pair of NS, 2 means 2 pair of NS;
c-y	1-9	Lifting speed	9 files, The smaller the number, the faster the speed. On the contrary, the slower the speed;
d-y	1-9	Anti-pinch value	0 means off, 1 is the lowest sensitivity, 9 is the highest sensitivity
e-y	1-9	Self-test stop time	The setting value multiplied by 2 is the stop time, For example, setting 2, Then the stop time is 4 minutes
H00	40-99	Base height	Indicates the minimum display height-Table lowered to lowest display height
n00	30-99	table itinerary	The height at which the table can be raised and lowered, The length that the table column can extend, This value determines the maximum height of the table, The highest height display is h00+n00;
L00	3-40	Screw lead	Indicates the lead - one turn of the screw, the raised height of the table, The lead parameters must be accurate, Otherwise, the table itinerary will be inaccurate.
F-y	0-1	Motor direction	0/1 Change motor direction
r-y	0-4	Screen off control	0, do not turn off the screen, 1, turn off the screen.

Error code table

error code	illustrate	How to handle
E01	motor not connected	Press the up or down button again, still exists, Please check the column motor connection line
E02	Motor overcurrent	Press the up or down button again, still exists, Please replace the motor or reduce the load
E03	Motor Hall fault	Press the up or down button again, still exists, Check connections or replace motor
E04	Abnormal main power	Cannot be eliminated after power failure, Replace the power supply
E05	Abnormal motor current	It cannot be eliminated after power failure and needs to be returned to the factory
E06	The motor power device is broken	It cannot be eliminated after power failure and needs to be returned to the factory
E08	Over temperature protection	wait for the temperature to drop
E09	Motor stall	Press the up or down button again, still exists, Please replace the motor or reduce the load
RST	Illegal power down	Reduce the load or check for loose power cables