

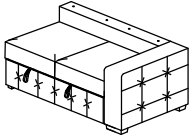

ASSEMBLY INSTRUCTION

Right Side 2-Seater with Pull-out Bed

LEGS AND HARDWARE ARE STORED IN THE BOTTOM OF THE SEAT, PLEASE TAKE OUT FOR ASSEMBLY.

NO.	PARTS LIST	QTY	DESCRIPTION
A		1	SEAT FRAME
B		2	HEADREST
C		2	2-SEATER BACK CUSHION

STEP # 1:

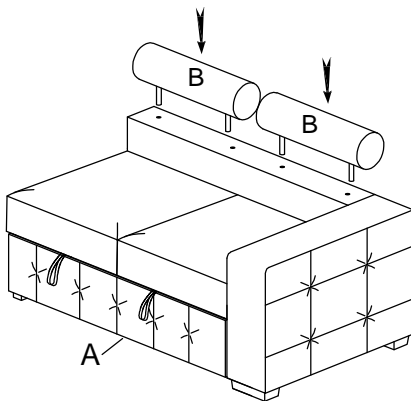

STEP # 2:

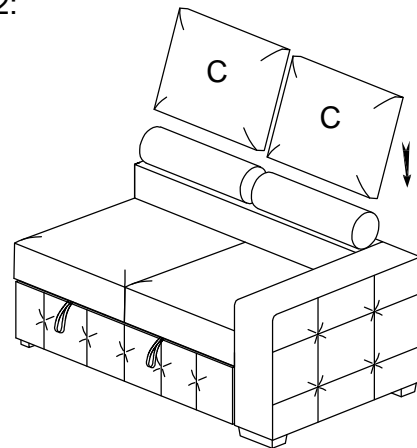

STEP # 3:

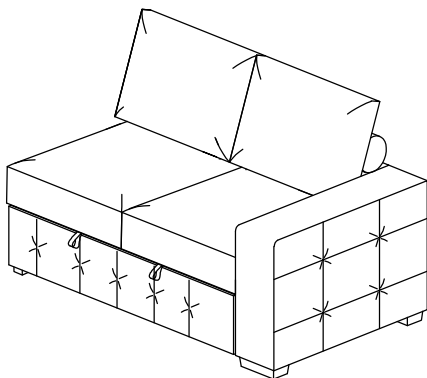

STEP # 4: COMPLETED

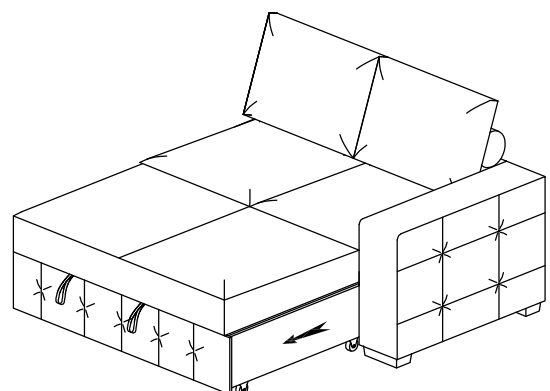



CARE INSTRUCTION FOR FABRIC FURNITURE

In order to maintain the original appearance of your fabric furniture, please follow below simple care procedures.

°Avoid exposing furniture directly to sunlight or heating and air conditioning outlets. Exposure to sunlight or heating and air conditioning outlets will fade/damage fabric.

°Wipe gently with a damp soft cloth to remove dust, dirt and any grime build up.

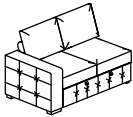
LEGS AND HARDWARE ARE STORED IN THE BOTTOM OF THE SEAT, PLEASE TAKE OUT FOR ASSEMBLY.

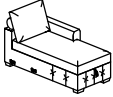
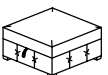
NO.	PARTS LIST	QTY	DESCRIPTION
A		1	Left side 2 seater - 2L
B		1	Corner seat - CR
C		1	Armless chair - 2A
D		1	Right side chaise - RC
E		1	Storage Ottoman - 4

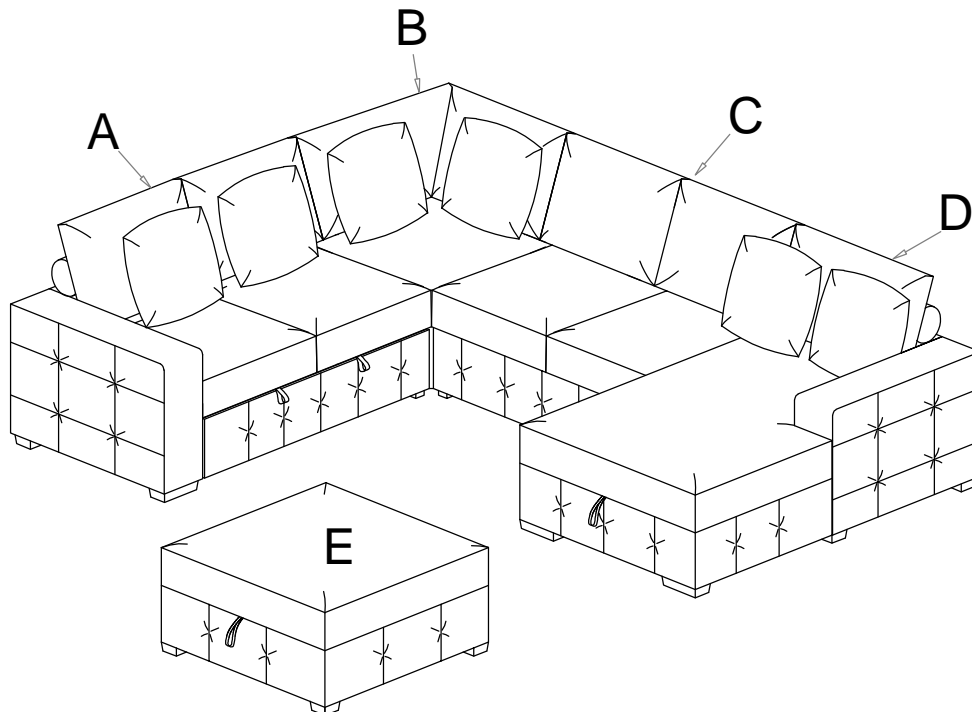

CARE INSTRUCTION FOR FABRIC FURNITURE

In order to maintain the original appearance of your fabric furniture, please follow below simple care procedures.



°Avoid exposing furniture directly to sunlight or heating and air conditioning outlets. Exposure to sunlight or heating and air conditioning outlets will fade/damage fabric.



°Wipe gently with a damp soft cloth to remove dust, dirt and any grime build up.

ASSEMBLY INSTRUCTION

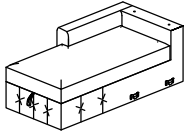
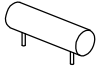
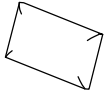
Left Side Chaise with Hidden Storage, 4pillows

LEGS AND HARDWARE ARE STORED IN THE BOTTOM OF THE SEAT, PLEASE TAKE OUT FOR ASSEMBLY.

NO.	PARTS LIST	QTY	DESCRIPTION
A		1	SEAT FRAME
B		1	HEADREST
C		1	CHAIR BACK CUSHION
G	 21"*21"	2	PILLOW BU/GY
H	 21"*21"	2	PILLOW BU/GY GEOMETRIC

NO.	HARDWARE LIST	QTY	DESCRIPTION
D	 248*100*45mm	5	WOODEN LEGS
E	 M8*50mm	10	Allen Bolt
F	 M5*100*38mm	1	Allen key

STEP # 1: Pillow (G) 1 pc + pillow (H) 1 pc are for BU-2R or GY-2R.

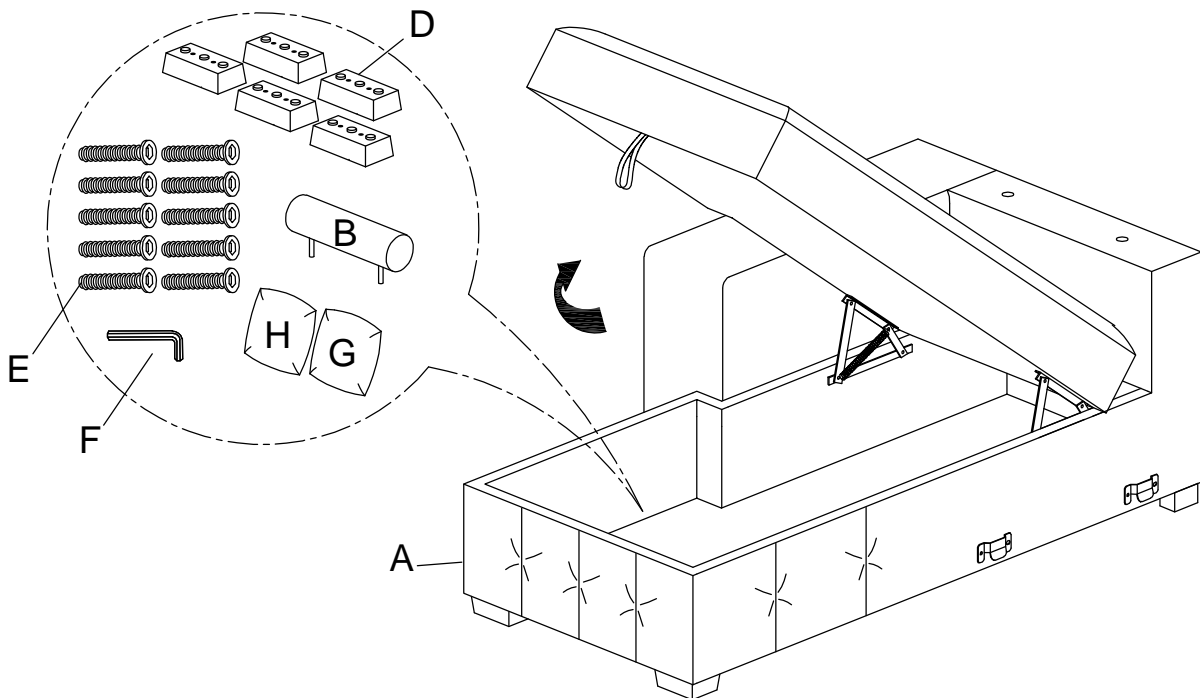

STEP # 2:

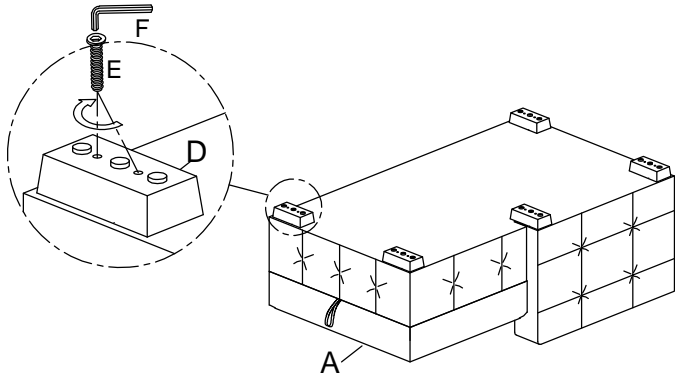

STEP # 3:

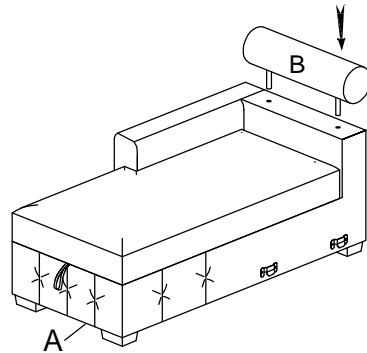

STEP # 4:

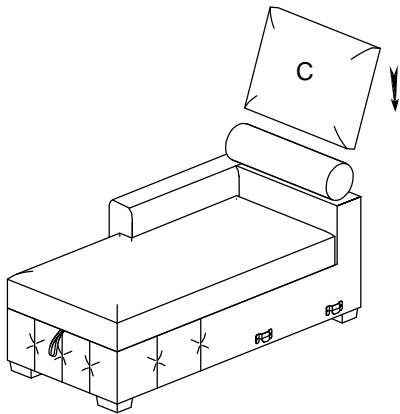

STEP # 5:

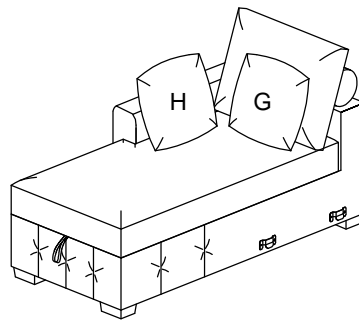

STEP # 6: COMPLETED

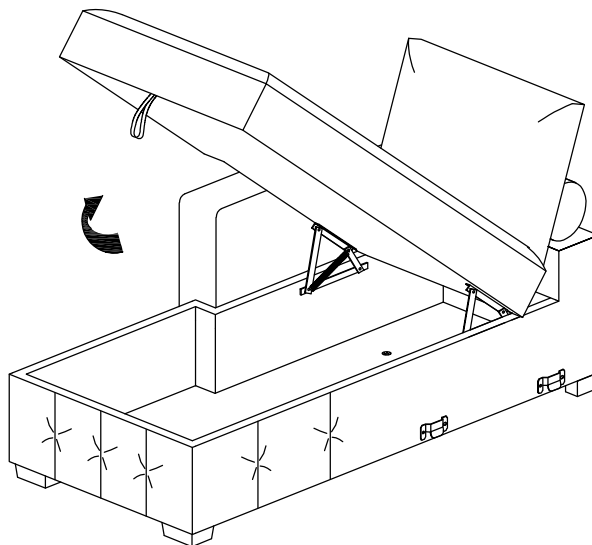





CARE INSTRUCTION FOR FABRIC FURNITURE

In order to maintain the original appearance of your fabric furniture, please follow below simple care procedures.

°Avoid exposing furniture directly to sunlight or heating and air conditioning outlets. Exposure to sunlight or heating and air conditioning outlets will fade/damage fabric.

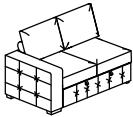
°Wipe gently with a damp soft cloth to remove dust, dirt and any grime build up.

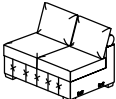
LEGS AND HARDWARE ARE STORED IN THE BOTTOM OF THE SEAT, PLEASE TAKE OUT FOR ASSEMBLY.

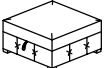
NO.	PARTS LIST	QTY	DESCRIPTION
A		1	Left side 2 seater - 2L
B		1	Corner seat - CR
C		1	Armless chair - 2A
D		1	Right side chaise - RC
E		1	Storage Ottoman - 4

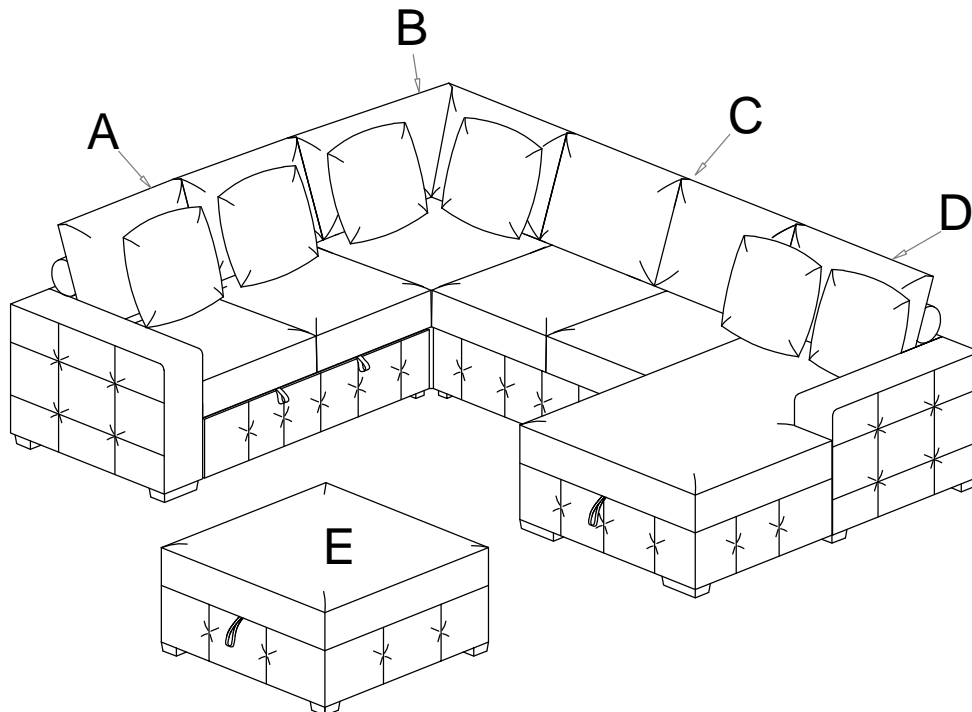

CARE INSTRUCTION FOR FABRIC FURNITURE



In order to maintain the original appearance of your fabric furniture, please follow below simple care procedures.



°Avoid exposing furniture directly to sunlight or heating and air conditioning outlets. Exposure to sunlight or heating and air conditioning outlets will fade/damage fabric.

°Wipe gently with a damp soft cloth to remove dust, dirt and any grime build up.

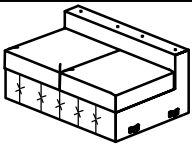
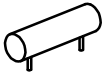
Armless 2-Seater

LEGS AND HARDWARE ARE STORED IN THE BOTTOM OF THE SEAT, PLEASE TAKE OUT FOR ASSEMBLY.

NO.	PARTS LIST	QTY	DESCRIPTION
A		1	SEAT FRAME
B		2	HEADREST
C		2	2-SEATER BACK CUSHION

NO.	HARDWARE LIST	QTY	DESCRIPTION
D		4	WOODEN LEGS
E	 M8*50mm	8	Allen Bolt
F	 M5*100*38mm	1	Allen key

STEP # 1:

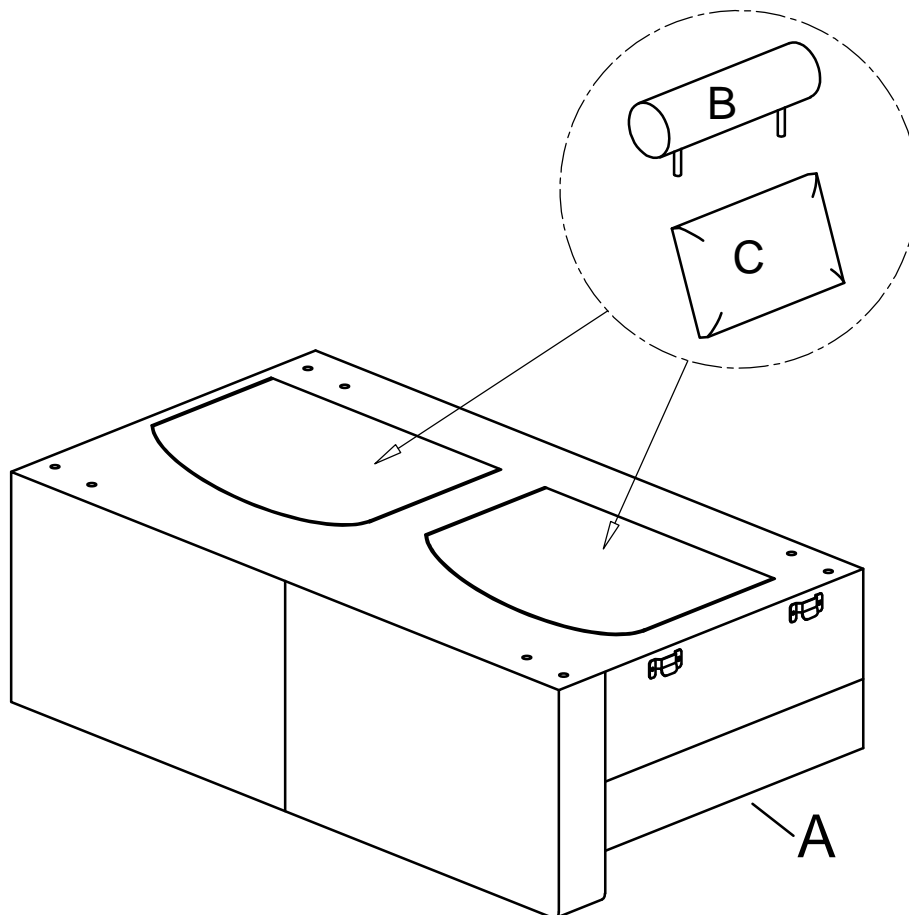

STEP # 2:

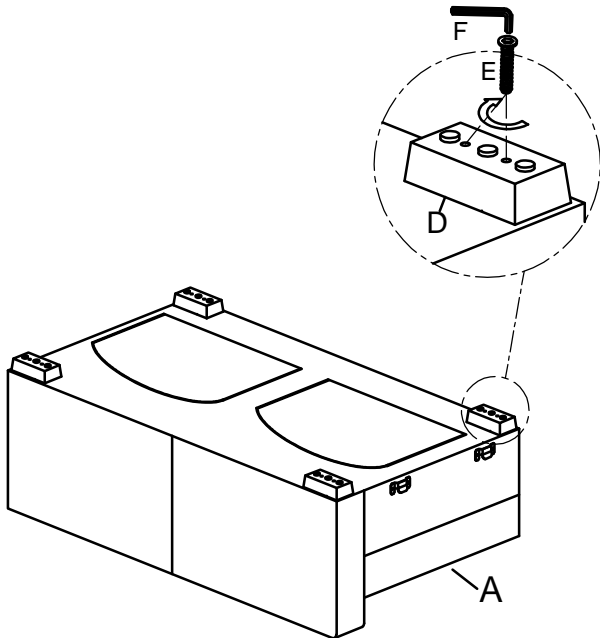

STEP # 3:

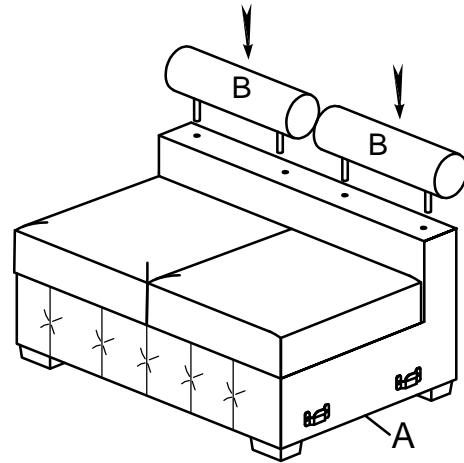

STEP # 4:

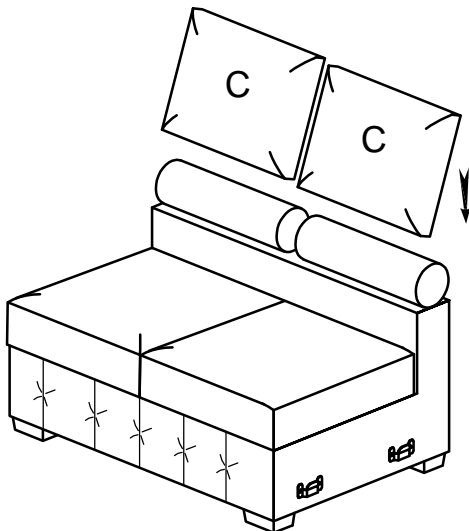

STEP # 5:

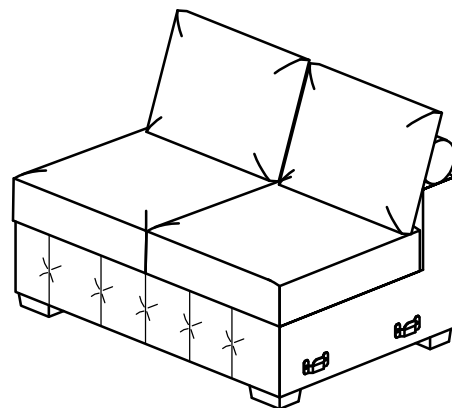





CARE INSTRUCTION FOR FABRIC FURNITURE

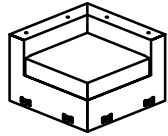
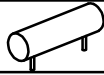

In order to maintain the original appearance of your fabric furniture, please follow below simple care procedures.

°Avoid exposing furniture directly to sunlight or heating and air conditioning outlets. Exposure to sunlight or heating and air conditioning outlets will fade/damage fabric.

°Wipe gently with a damp soft cloth to remove dust, dirt and any grime build up.

LEGS AND HARDWARE ARE STORED IN THE BOTTOM OF THE SEAT, PLEASE TAKE OUT FOR ASSEMBLY.

NO.	PARTS LIST	QTY	DESCRIPTION
A		1	SEAT FRAME
B		2	HEADREST
C		1	SMALL BACK CUSHION
D		1	BIG BACK CUSHION
E		1	PILLOW BLUE OR GRAY
F		1	PILLOW BLUE/WHITE GEOMETRIC OR GRAY/WHITE GEOMETRIC

NO.	HARDWARE LIST	QTY	DESCRIPTION
G		4	WOODEN LEGS
H	 M8*50mm	8	Allen Bolt
I	 M5*100*38mm	1	Allen key

STEP # 1:

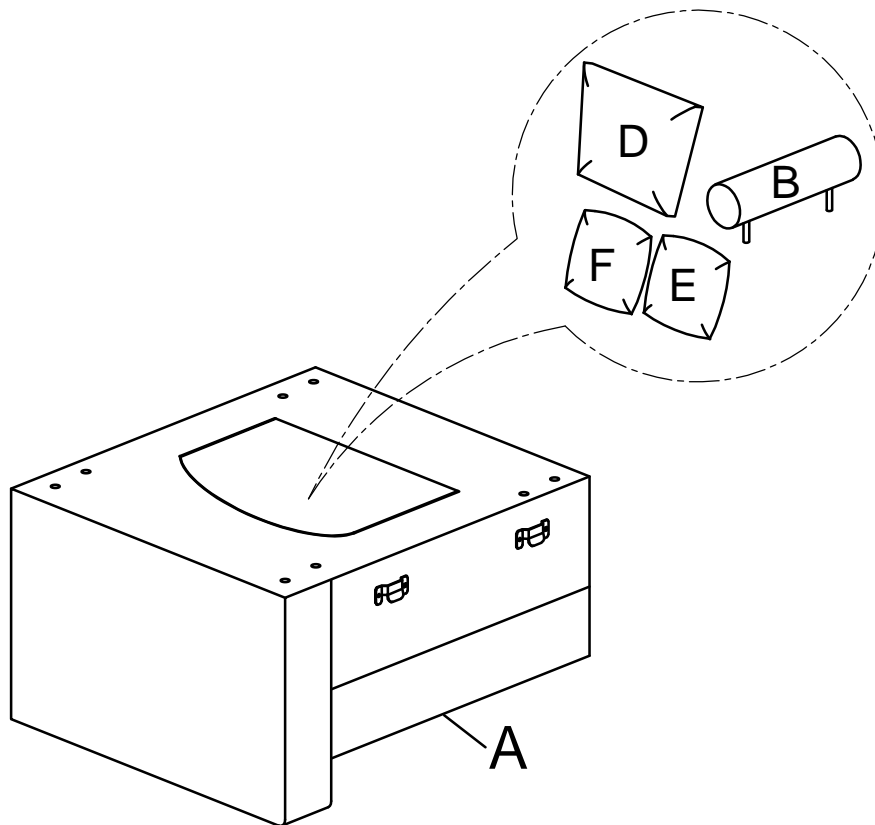

STEP # 2:

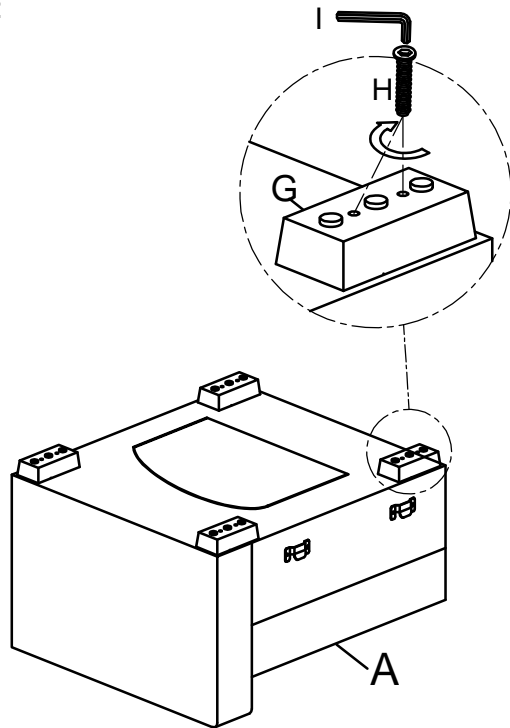

STEP # 3:

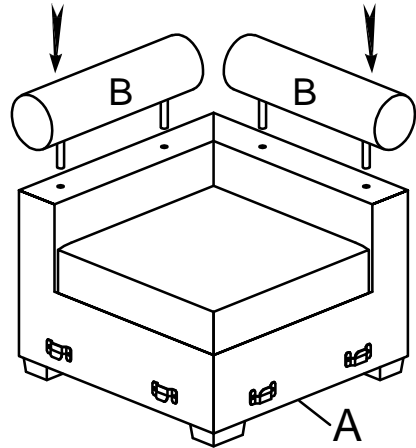

STEP # 4:

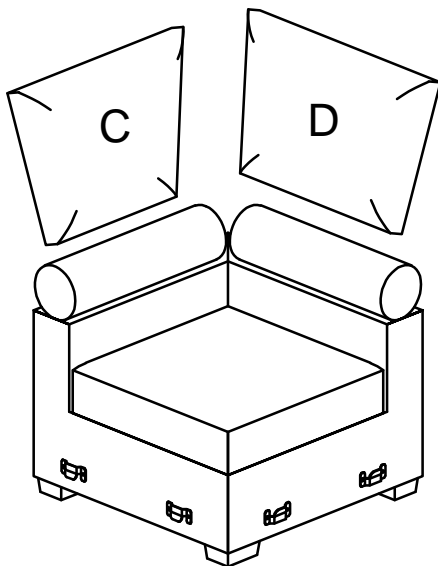

STEP # 5:

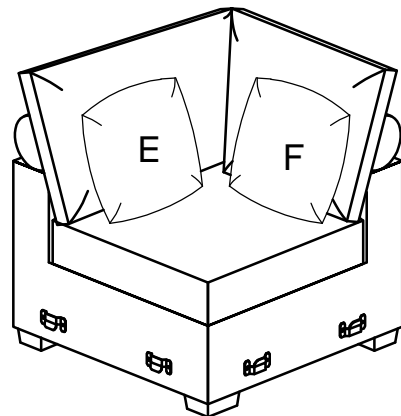

CARE INSTRUCTION FOR FABRIC FURNITURE

In order to maintain the original appearance of your fabric furniture, please follow below simple care procedures.

°Avoid exposing furniture directly to sunlight or heating and air conditioning outlets. Exposure to sunlight or heating and air conditioning outlets will fade/damage fabric.

°Wipe gently with a damp soft cloth to remove dust, dirt and any grime build up.