

ASSEMBLY INSTRUCTIONS  
MODEL : COFFEE TABLE

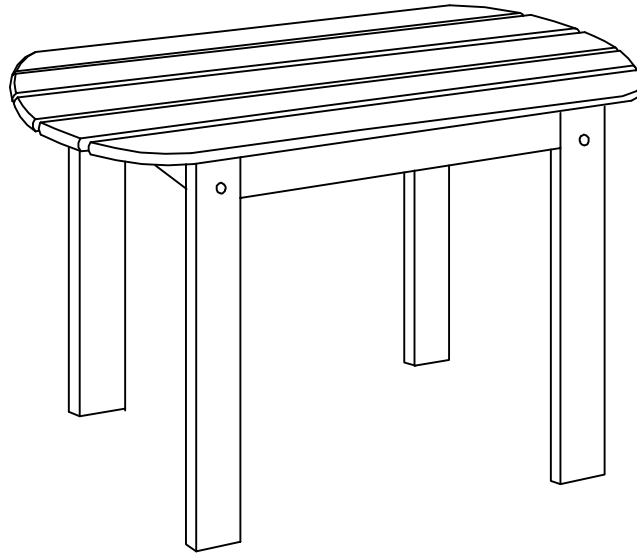

**WE ARE HERE TO HELP!**

We do our best to insure that your furniture arrives in excellent condition.

**IMPORTANT:  
PLEASE READ ALL INSTRUCTIONS IN THIS BOOKLET BEFORE STARTING ASSEMBLY.  
MADE IN MALAYSIA**

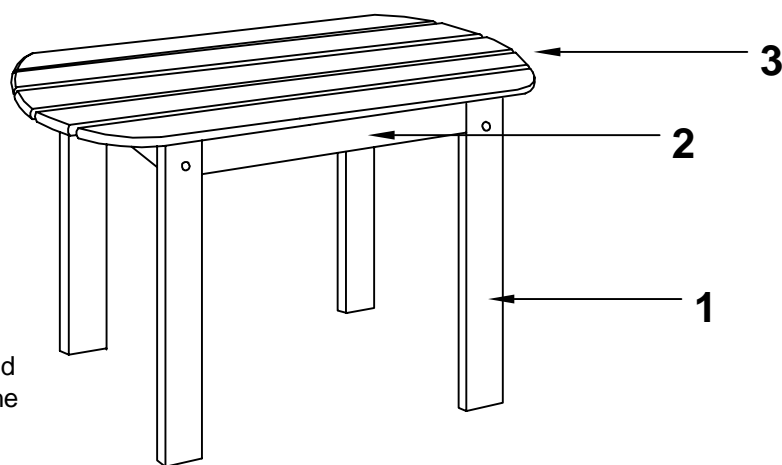

## PARTS IDENTIFICATION

PART	DESCRIPTION	QUANTITY
#1	TABLE LEG	2PCS
#2	APRON	2PCS
#3	TABLE TOP	1PC



For ease of identification all parts are labeled to correspond to the step number in which the part is used.

## HARDWARE IDENTIFICATION

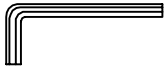
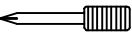
CODE	DESCRIPTION	QUANTITY
A	 JCBC SCREW M6 X 60MM	4PCS
B	 JCBC SCREW M6 X 30M	4PCS
C	 BARREL NUT	4PCS
D	 ALLEN KEY	1PC
E	 SPMINI SCREW DRIVER BIT	1PC

NOTE: QUANTITIES SHOWN ARE FOR ONE (1) TABLE

LEASE USE ALL HARDWARE PROVIDED TO ENSURE STABILITY AND SAFETY OF THE PRODUCT.

BEFORE ASSEMBLY - CLEAN A LARGE AREA, SPREAD NEWSPAPER OR USE A CARPET FLOOR TO ASSEMBLE ALL PIECES. THIS WILL PROTECT THE ITEM DURING ASSEMBLY.

**STEP 1**

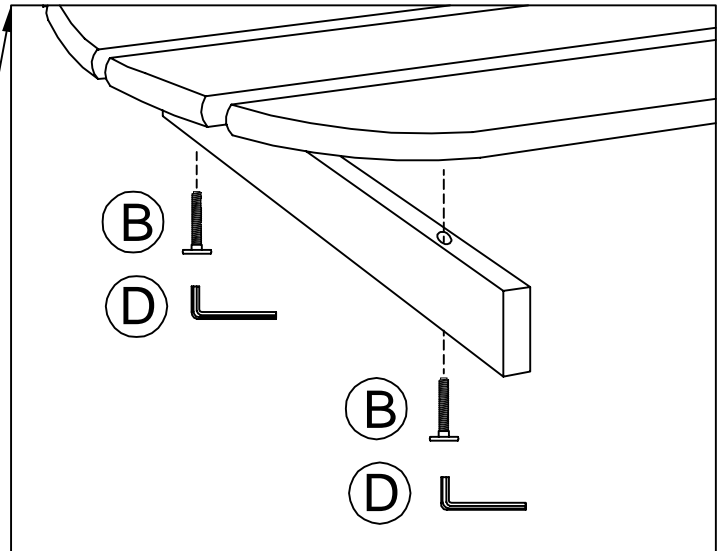

FIX(02) APRON #2 TO TABLE TOP #3. USING (04) SCREW (B). TIGHTEN BY USING ALLEN KEY (D).

**STEP 2**

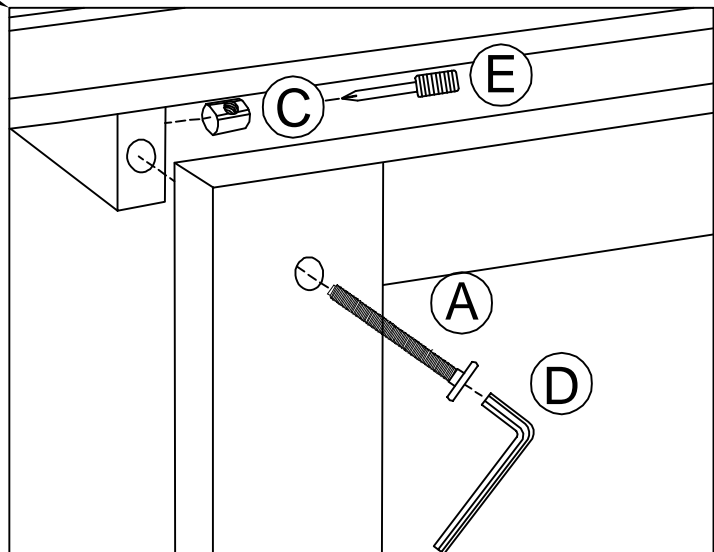

FIX (02) LEG #1 TO APRON #2 AND TABLE TOP #3 ALREADY ASSEMBLED. USING (04) SCREW (A) AND (04) BARREL NUT (C) TIGHTEN BY USING ALLEN KEY (D) AND MINI SCREW DRIVER BIT (E).

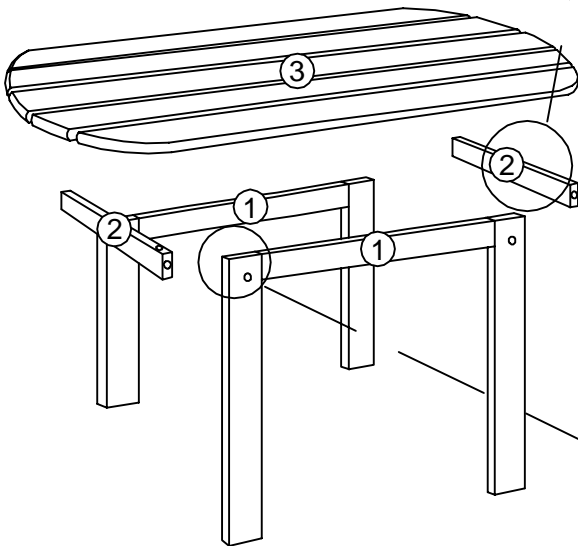

**ASSEMBLY COMPLETE**

