









ASSEMBLY INSTRUCTIONS

Description : Wing Bench
Item No :D35

NO	Parts List	Q'TY
1	CHAIR FRAME WITH CUSHION SEAT 	1PC
2	FRONT LEG 	2PCS
3	REAR LEG (2L & 1R) OR (1L & 2R) 	3PCS
4	MIDDLE LEG 	1PC

NO	Hardware List	Q'TY
A	BOLT  Ø1/4" * 50 mm	12 PCS
B	LOCK WASHER  Ø1/4" * 11* 1.5 mm	12 PCS
C	WASHER  Ø1/4" * 22 *2 mm	12 PCS
D	ALLEN KEY  58 * 4mm	1PC

STEP 1

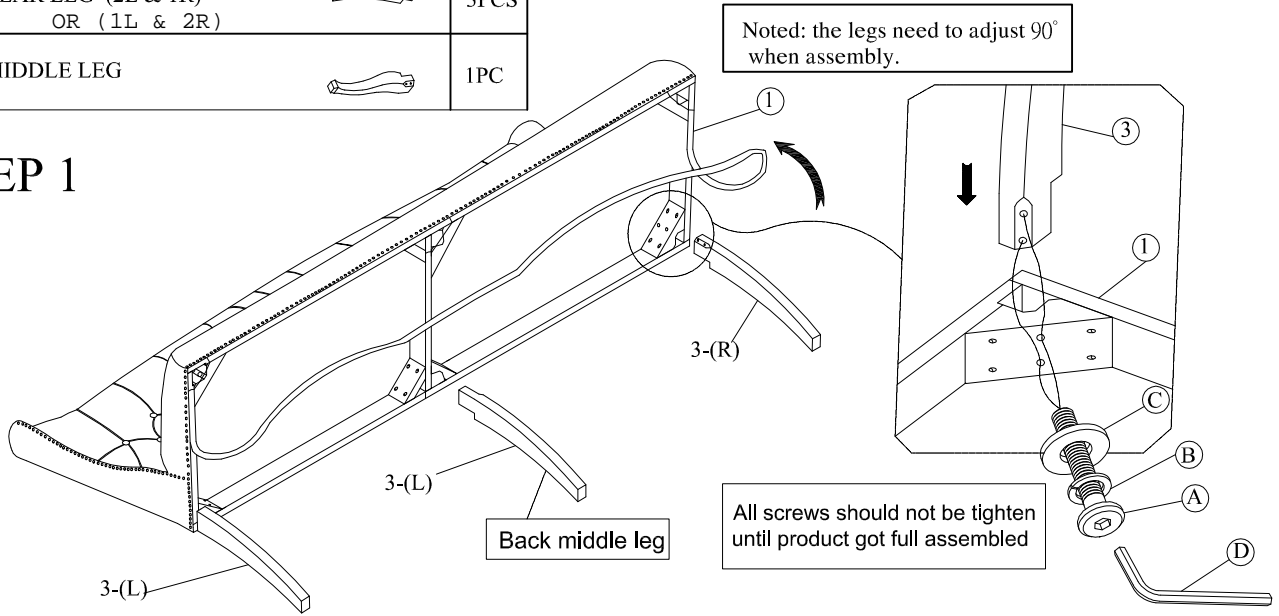

STEP 2

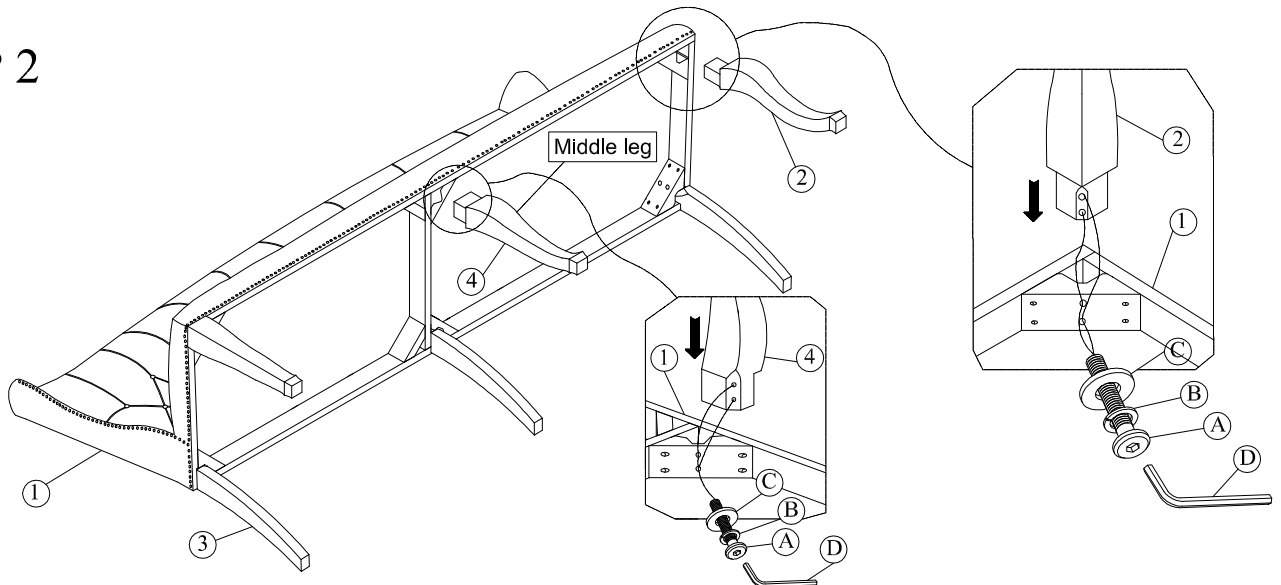

STEP 3

