

IBOCONSOLE

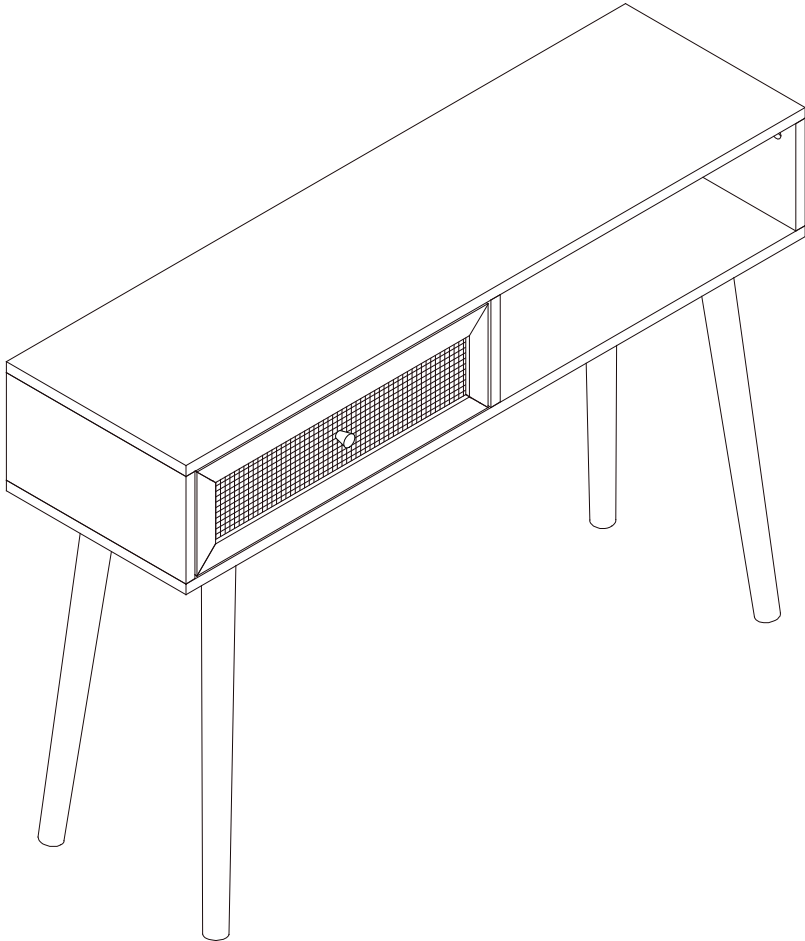

FRANÇAIS

Conseils d'entretien.....	5
Conseils d'utilisation.....	5
Avertissements.....	6
Montage.....	7

**IMPORTANT, À CONSERVER
POUR CONSULTATION ULTÉRIEURE :
À LIRE ATTENTIVEMENT**

ENGLISH

Directions for maintenance.....	5
Directions for use.....	5
Warning.....	6
Assembly.....	7

**IMPORTANT, TO KEEP FOR FUTURE
REFERENCE: TO READ CAREFULLY**

NEDERLANDS

Onderhoud.....	5
Gebruiksaanwijzing.....	5
Waarschuwingen.....	6
Montage.....	7

**BELANGRIJK, BEWAAR VOOR
TOEKOMSTIGE REFERENTIE:
ZORGVULDIG LEZEN**

DEUTSCH

Pflegehinweis	5
Verwendungstipps	5
Warnhinweise	6
Montage.....	7

**WICHTIG, FÜR SPÄTEREN
GEBRAUCH AUFBEWAHREN:
AUFMERKSAM LESEN**



Attention : risques de blessures
Warning: risks of injuries
Waarschuwing: risico op verwondigen
Warnung : Verletzungsgefahr



Garantie : 2 ans
Guarantee: 2 years
Garantie: 2 jaar
Garantie: 2 Jahre



Destiné à un usage domestique
Reserve to a domestic use
Bestemd voor huishoudelijk gebruik
Bestimmt für den Privatgebrauch

CONSEILS D'ENTRETIEN / DIRECTION FOR MAINTENANCE / ONDERHOUD / PFLEFEHINWELS

FR

Dépoussiérer régulièrement avec un chiffon propre, doux et sec.
Proscrire tout abrasif et produits acides. Ne jamais employer de solvants.

EN

Regularly dust with a clean, soft and dry duster.
Forbid any scourer and acidic products. Never use cleaning solvent.

NL

Stof regelmatig af met een schone, zachte en droge doek.
Sluit alle schurende en zure producten uit. Gebruik nooit oplosmiddelen.

DE

Regelmäßig mit einem sauberen, weichen und trockenen Tuch abstauben. Keinesfalls
abrasive und ätzende Reinigungsprodukte anwenden. Verwenden Sie niemals Lösungsmittel.

CONSEILS D'UTILISATION / DIRECTIONS FOR USE / GEBRUIKSAANWIJZING / VERWENDUNGSTIPPS

FR

Pour des raisons de stabilité, et afin de préserver les pas de vis d'un serrage de travers, il est impératif d'assembler manuellement tous les éléments, et de serrer toutes les vis à la main dans un premier temps. Une fois l'assemblage terminé, vous pouvez procéder au serrage de la visserie de manière plus ferme.

EN

For stability reasons and in order to preserve the screw pitch from a crook line, it is imperative to assemble each piece by hand first. Once the assembly is over, you can proceed to do the screw tightening firmly.

NL

Omwille van de stabiliteit en om doordraaien te voorkomen, is het van cruciaal belang om alle elementen handmatig te monteren en alle schroeven in eerste instantie met de hand aan te halen. Na de montage kunt u de schroeven steviger vastzetten.

DE

Aus Stabilitätsgründen und um ein Überziehen der Gewinde zu verhindern, müssen unbedingt alle Komponenten manuell zusammengebaut und alle Schrauben zuerst von Hand angezogen werden. Sobald die Montage abgeschlossen ist, können Sie die Hardware fester anziehen.

AVERTISSEMENTS / WARNING / WAARSCHUWINGEN / WARNHINWEISE

FR

ATTENTION : Risque de blessure grave ou mortelle en cas de basculement du meuble. Pour éviter que le meuble ne bascule, il faut le fixer au mur de façon permanente à l'aide des pièces incluses pour la fixation. Les vis et chevilles ne sont pas incluses car leur choix dépend du matériau du mur sur lequel est fixé le meuble. Utilisez des vis et chevilles adaptées au matériau du mur.

EN

CAUTION : Risks of mortal or serious injuries in case of the furniture toppling. To avoid the furniture toppling you have to fix it on the wall permanently with the included fixing pieces. Screw and dowels are not included, their choice depends on the wall material in which the furniture will be fixed to. Use adapted screws and dowels according to the wall material.

NL

WAARSCHUWING : Wanneer meubels omvallen, kaner ernstig of levens bedreigend beklemmingsletsel ontstaan. Om te voorkomen dat dit meubel omvalt, dient dit permanent met de meegeleverde wandbevestigingen aan de wand te worden bevestigd. Bevestigingsbeslag voor de wand is niet inbegrepen, aangezien verschillende soorten bevestigingsbeslag dat geschikt is voor de wanden in je huis

DE

ACHTUNG : Wenn Möbelstücke umkippen, können ernste oder lebensgefährliche Verletzungen durch Einklemmen die Folge sein. Um zu verhindern, dass dieses Möbelstück umkippt, muss es mit den beigegepackten Vorrichtungen zur Wandbefestigung fest an der Wand verankert werden. Beschläge für die Wandbefestigung sind nicht beigegepackt, da sie von der Beschaffenheit der Wand und des Untergrundmaterials abhängig sind. Befestigungsbeschläge

MONTAGE / ASSEMBLY

A



× 8

B



× 8

C



× 16

D



× 12

E



× 8

F



× 20

G



× 4

H



× 1

I



× 4

J



× 2

CL

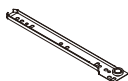

× 1

CR

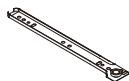

× 1

DL

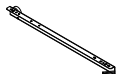

× 1

DR

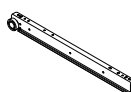

× 1

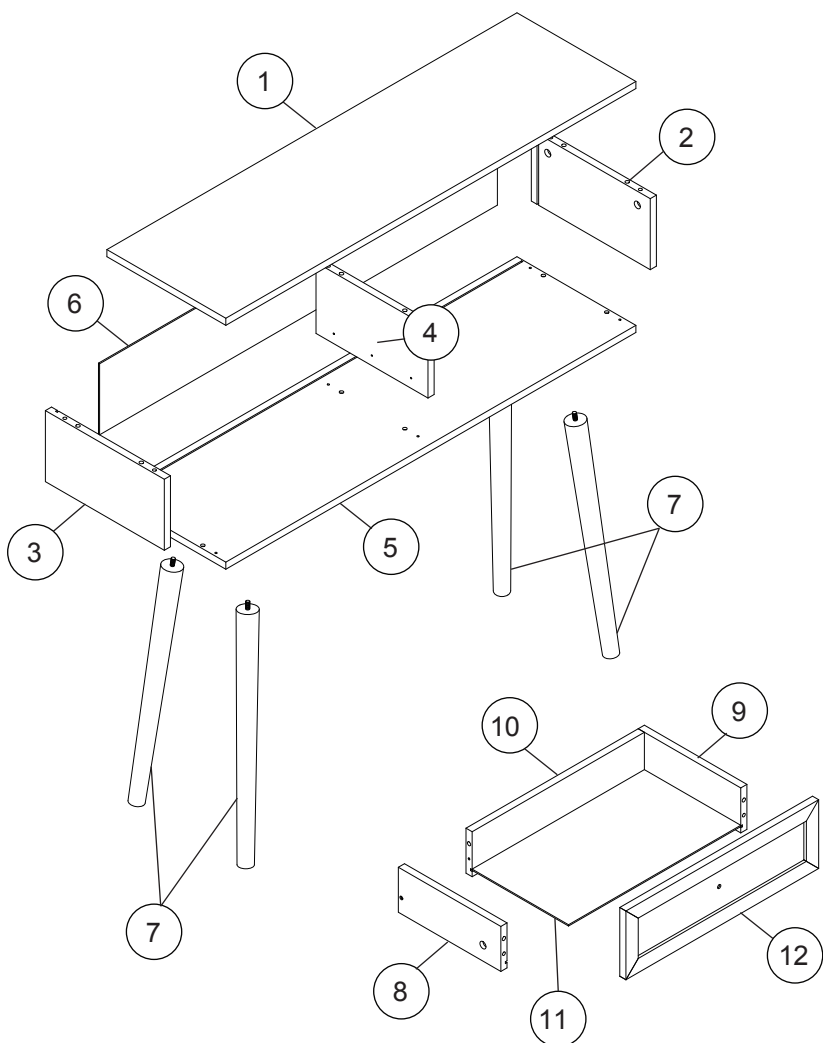

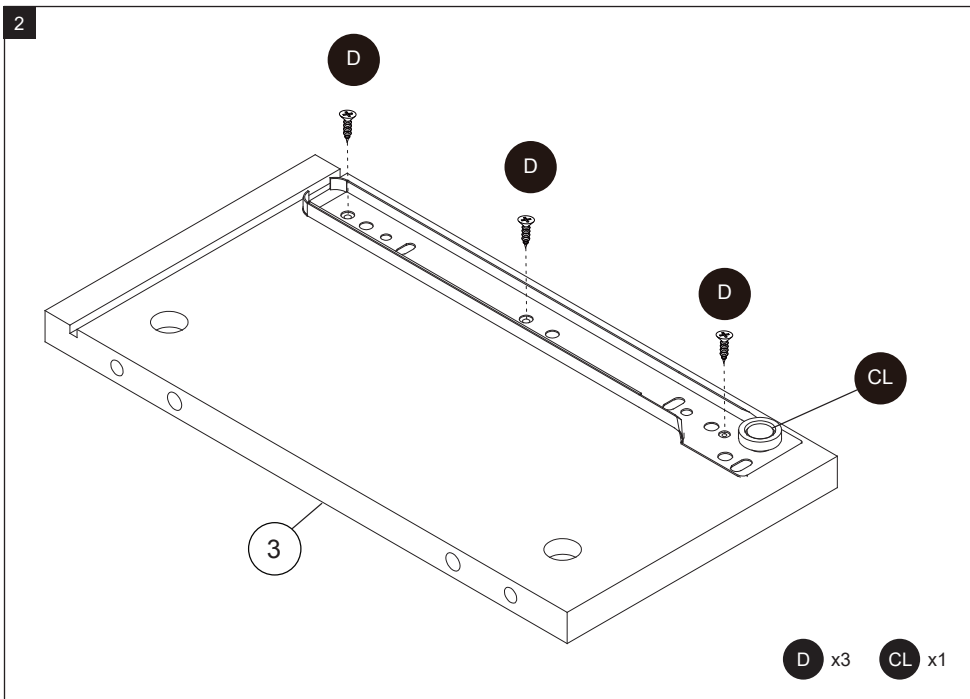
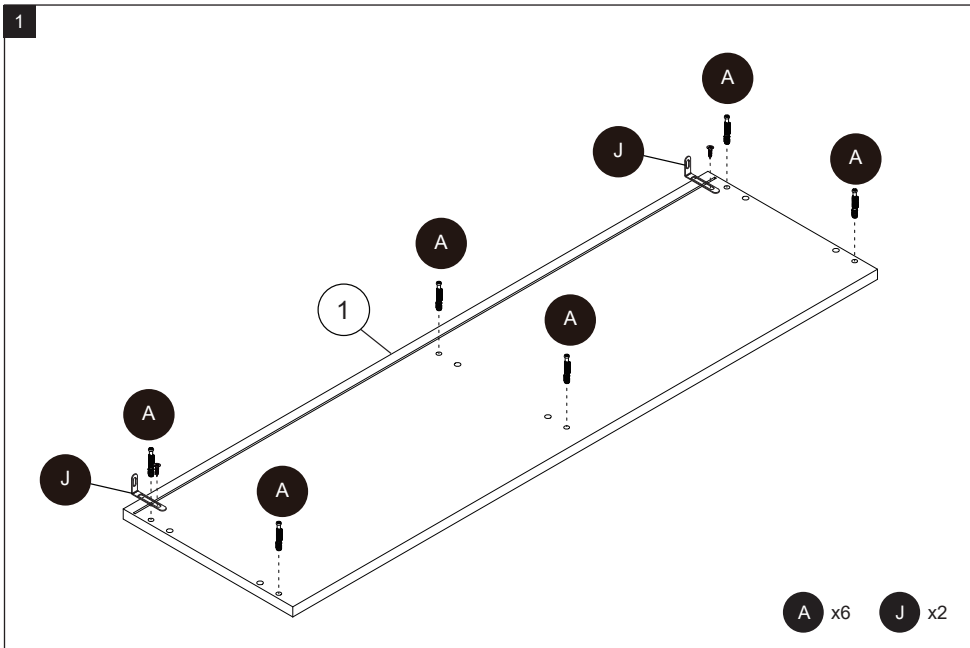

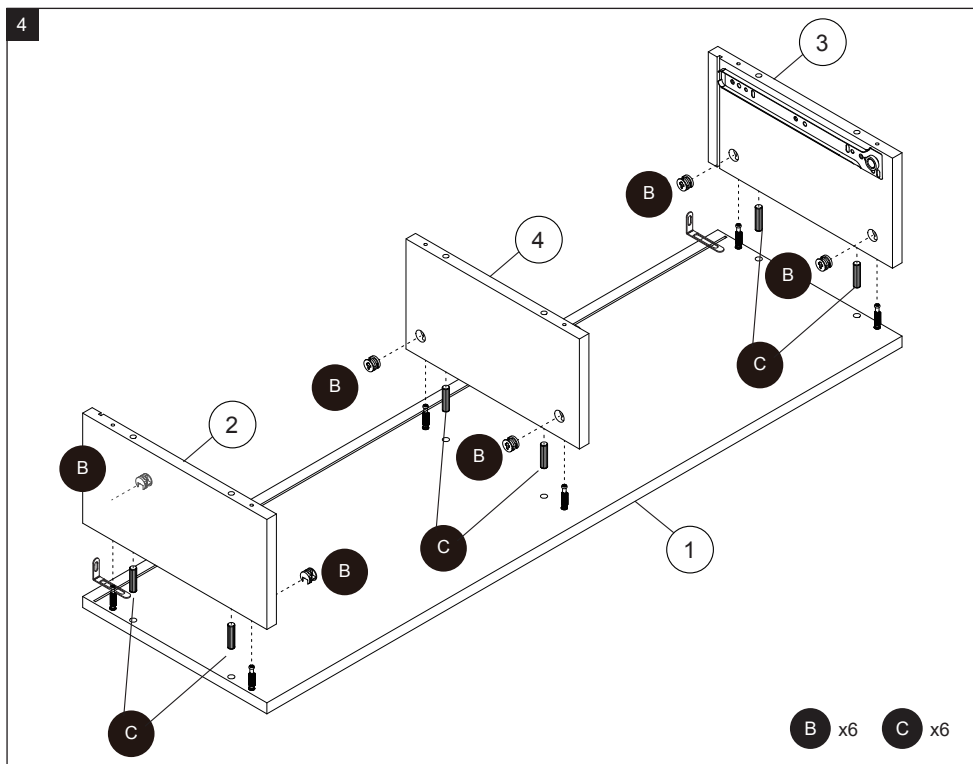
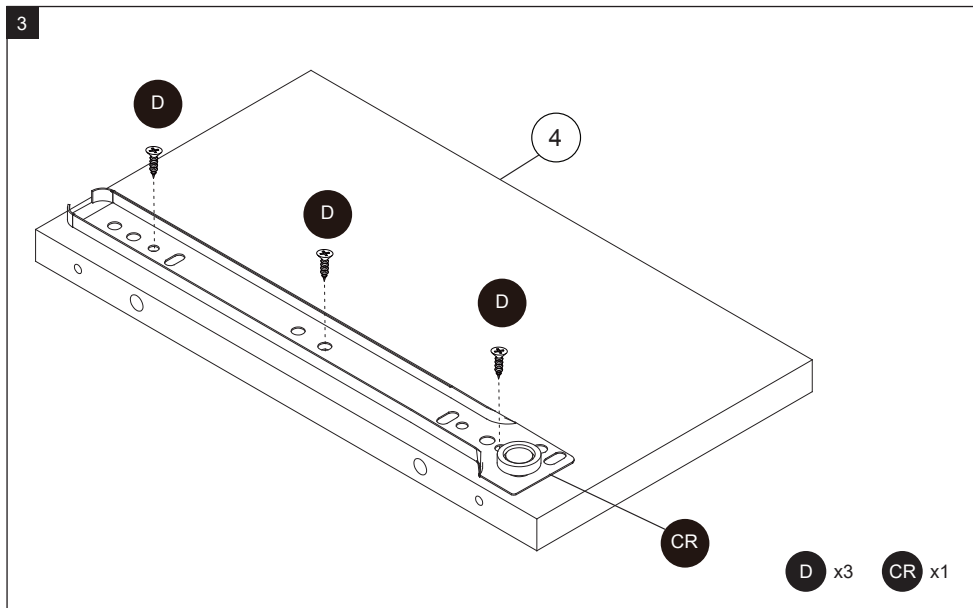

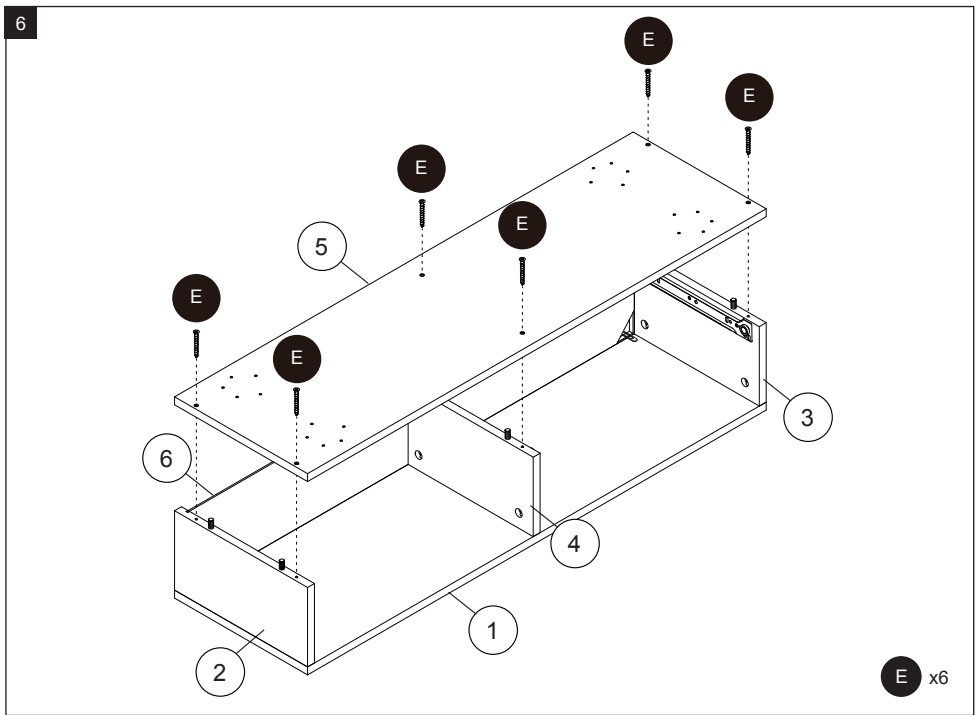
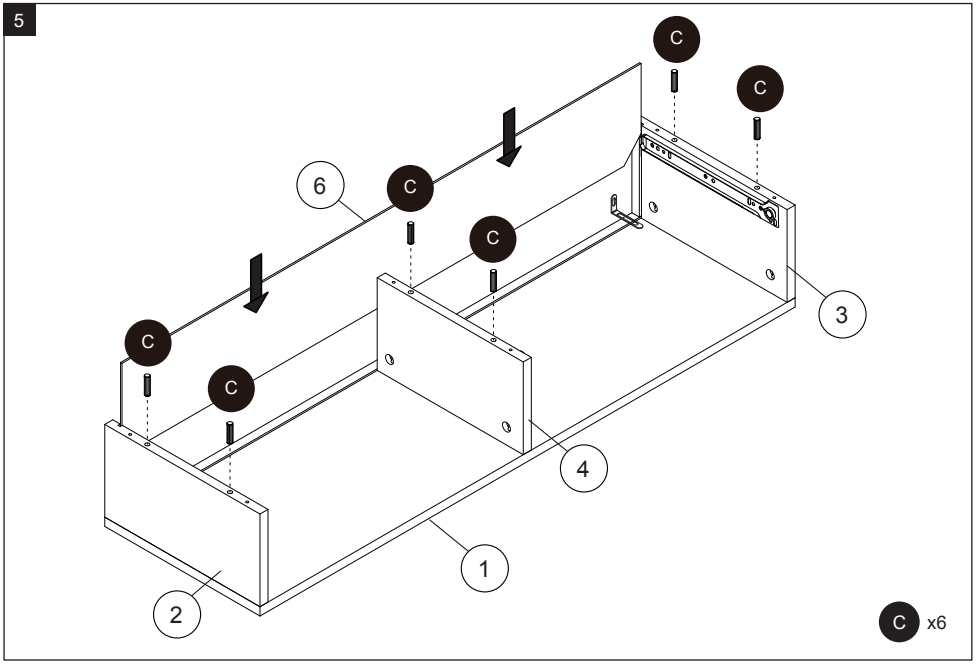

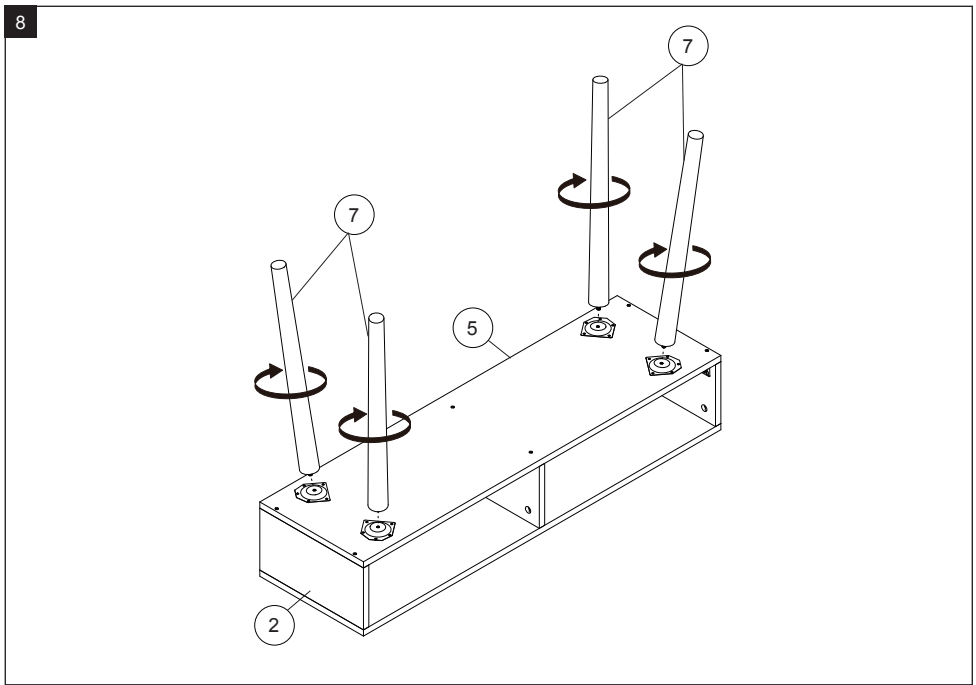
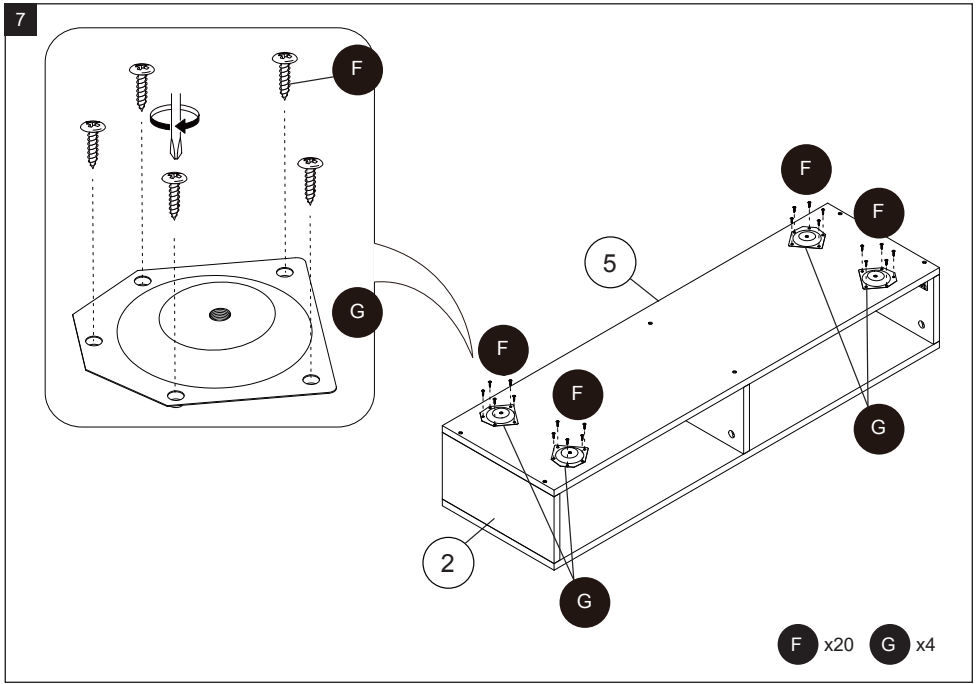

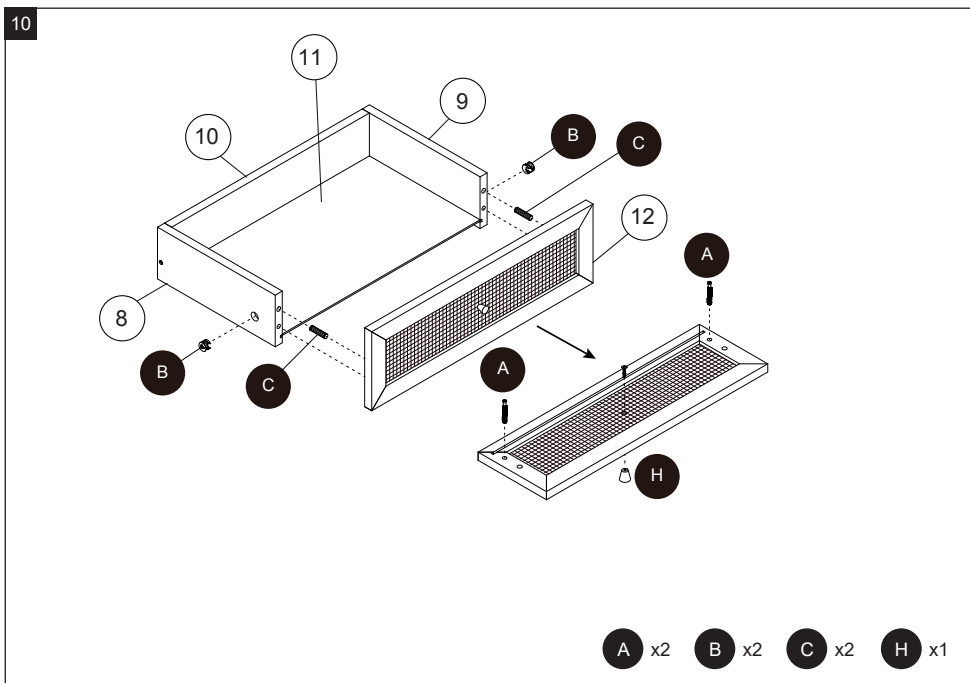
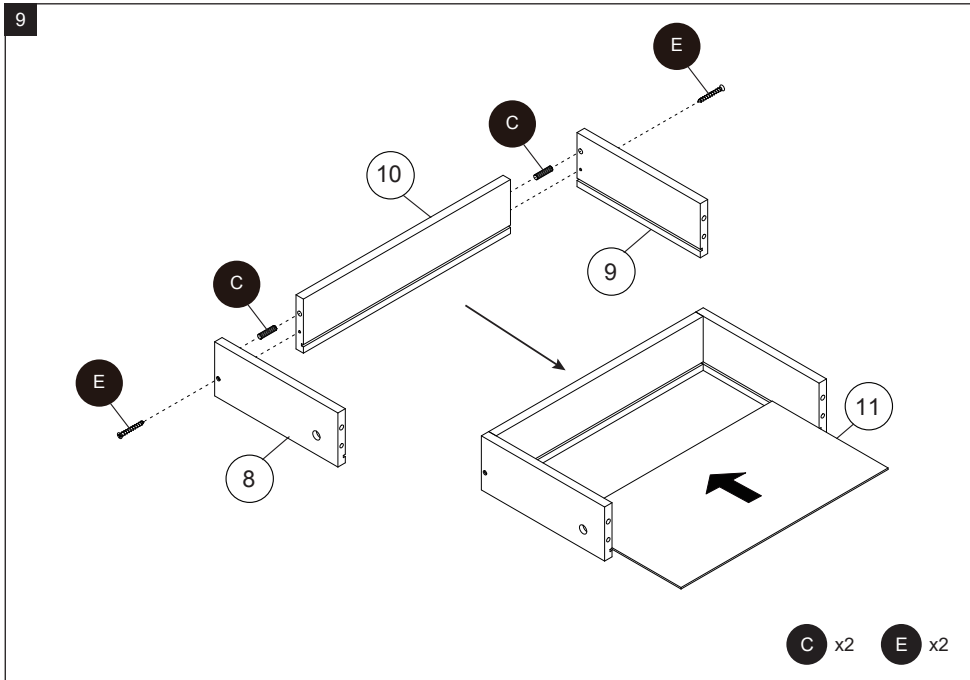

11

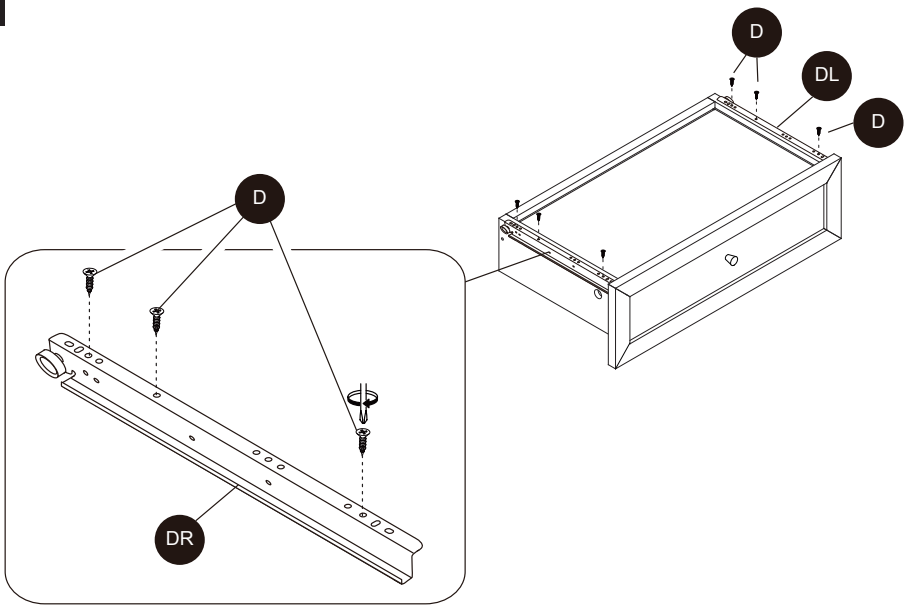

D x6 DL x1 DR x1

12

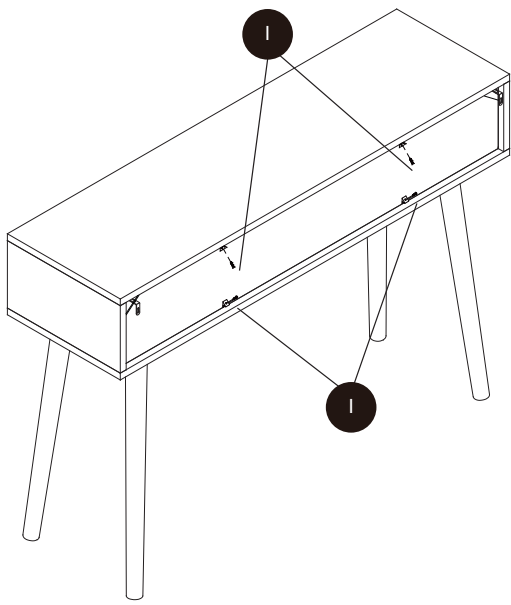

I x4

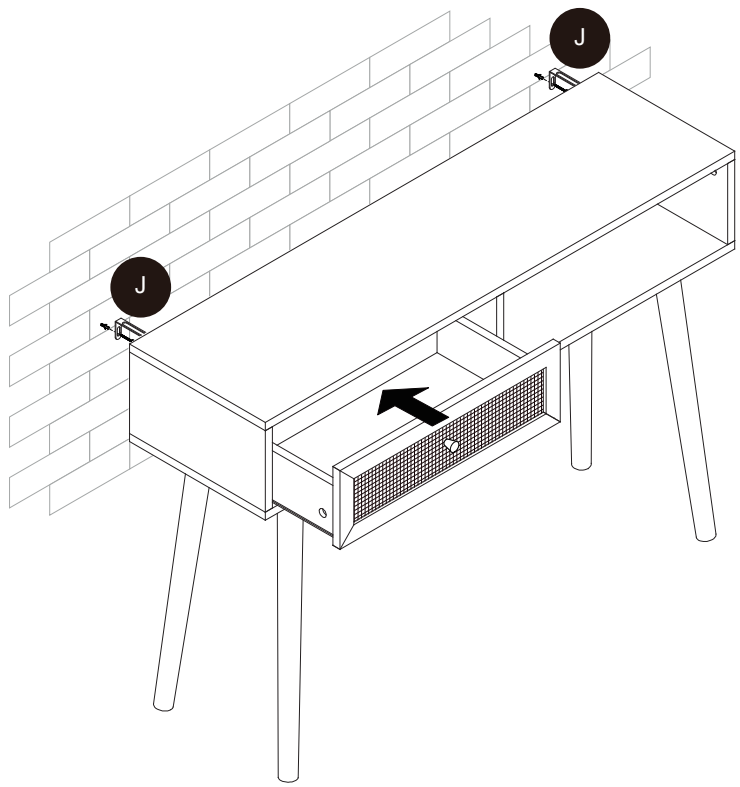

J x2

IMPORTÉ PAR WALIBUY SAS
270 avenue de l'Espace, 59118 WAMBRECHIES - FRANCE
Service après vente : **sav.alicesgarden.fr - sav.alicesgarden.be**

IMPORTADO POR WALIBUY SPAIN SL
Carrer de Mallorca 289, Entresuelo 2, 08037 BARCELONA - ESPAÑA
Servicio postventa : **alicesgarden.es/cms/contacto**

IMPORTED BY ALICE'S GARDEN UK LTD
Office G07, Dowgate Hill House, EC4R 2SU London - UNITED KINGDOM
After sales service: **alicesgarden.co.uk/cms/contact-us**

INGEVOERD DOOR WALIBUY SAS
270 avenue de l'Espace, 59118 WAMBRECHIES - FRANKRIJK
After-sales : **aftersales.alicesgarden.nl - aftersales.alicesgarden.be**

IMPORTADO PARA WALIBUY SPAIN SL
Carrer de Mallorca 289, Entresuelo 2, 08037 BARCELONA - ESPAÑA
Serviço pós-venda : **alicesgarden.pt/cms/contacto**

IMPORTATO DA WALIBUY ITALIA S.R.L
Via Torino 60, 20123 MILANO - ITALIA
Contatto : **contatto@alicesgarden.it**

IMPORTED BY ALICE'S GARDEN OUTDOOR PTY LTD
SHOP 1, 1 Denham Street Bondi 2026 NSW - AUSTRALIA
Contact : **service@alicesgarden.com.au**

IMPORTIERT VON WALIBUY SAS
270 AVENUE DE L'ESPACE, 59118 WAMBRECHIES - FRANKREICH
Kundendienst : **kundenservice@alicesgarden.de**
