

ASSEMBLY INSTRUCTIONS

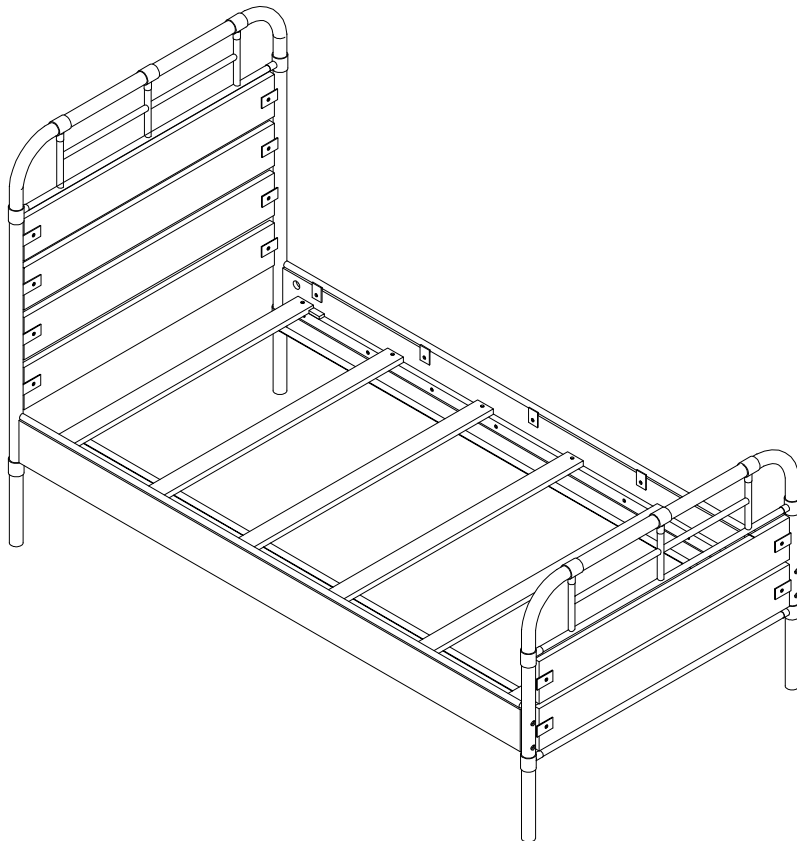



*** Thank you for purchasing this quality product. Be sure to check all packing materials carefully for small parts which may have come loose inside the carton during shipment. Identify and count all parts and compare with parts list below.

*** Assemble product on a flat, soft surface such as a carpet or cloth to prevent scratching the finish. Read all instruction and study the drawings carefully before starting the assembly process.





IMPORTANT: Do not tighten bolts completely until all bolts are completely lined up and inserted into holes

PARTS LIST







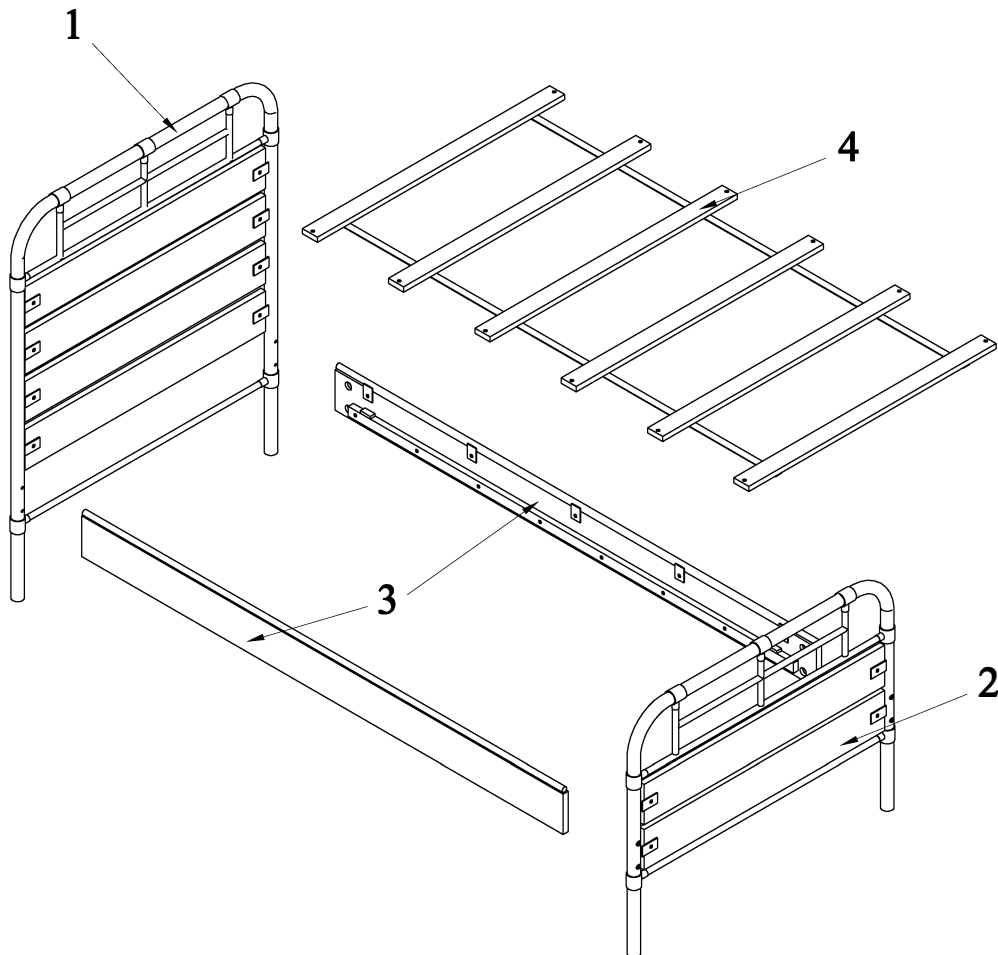

NO.	DIAGRAM	PART NAME	Q'Ty
1		Headboard	1 pc
2		Footboard	1 pc
4		Completed Twin Slat (6pcs/1set)	1 pc
3		Front, Back Rail	2 pcs

HARDWARE LIST

NO.	DIAGRAM	PART NAME	Q'Ty
A		Bolt: 6.3 * 80 (mm) Half Round Nut	8 sets
B		Screw: 4 * 30 (mm)	12 pcs
C		Allen Key (M4)	1 pc

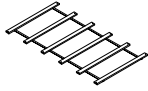

is packed in 2 cases

Carton	Disignation	Part		Hardware
	Headboard x 1pc	#1		 Bolt: 6.3 * 80 (mm)  Half Round Nut  Screw: 4 * 30 (mm)  Allen Key (M4)
	Footboard x 1pc	#2		
	Completed Twin Slat (6pcs/1set)	#4		
	Rails x 2pcs	#3		

STEP 1: HEADBOARD & FOOTBOARD ASSEMBLY

A  **8 set**

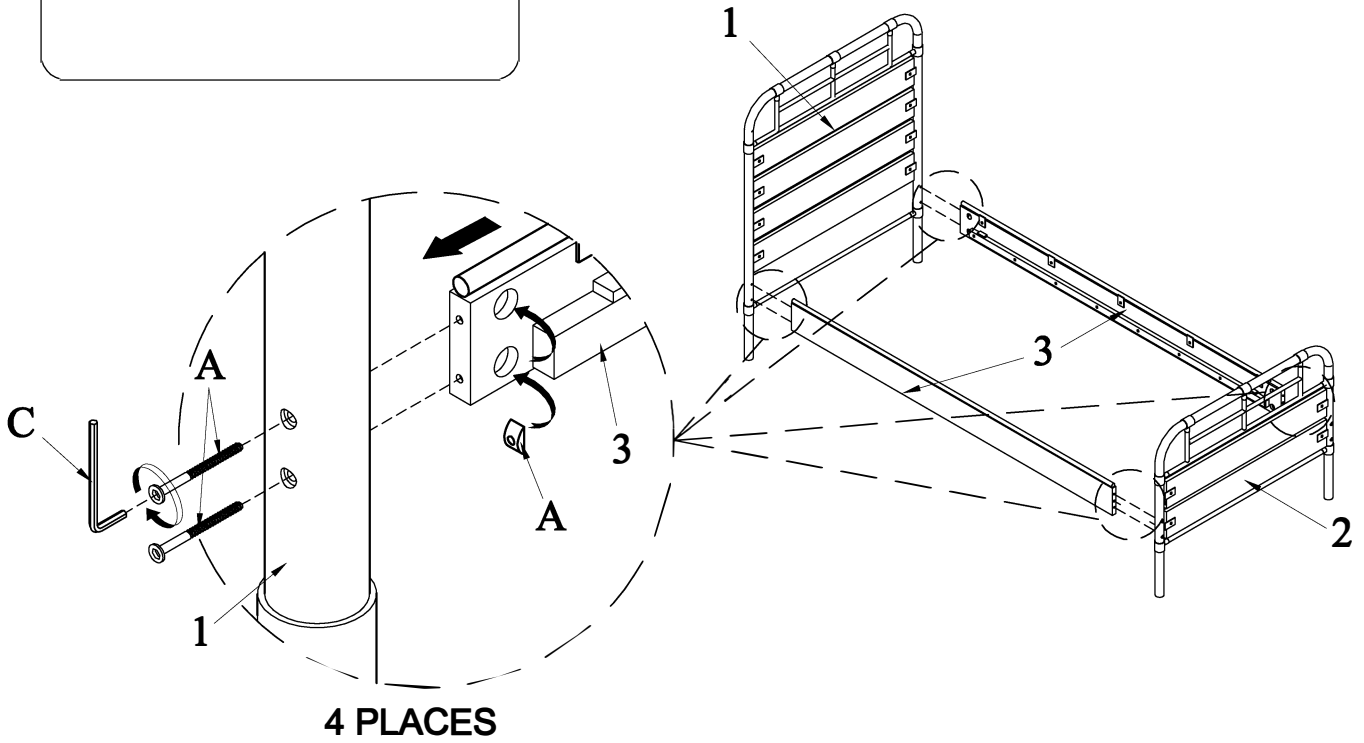

STEP 2: COMPLETED TWIN SLAT ASSEMBLY

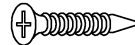
B  **12 pcs**

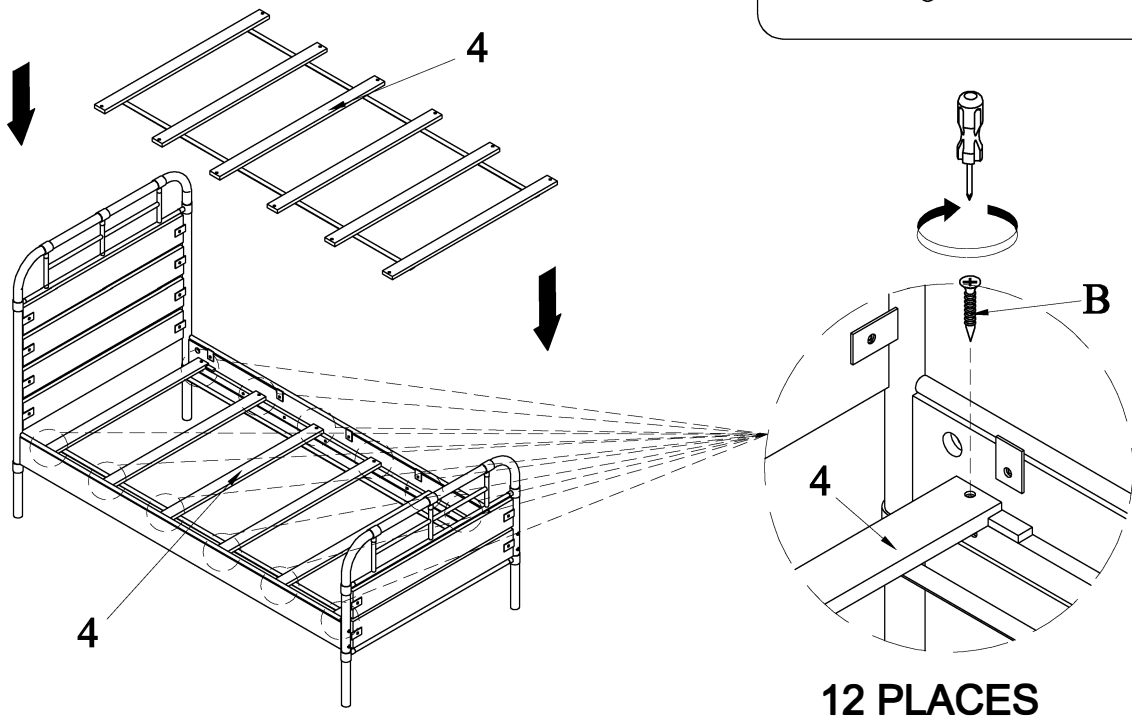

STEP 3:

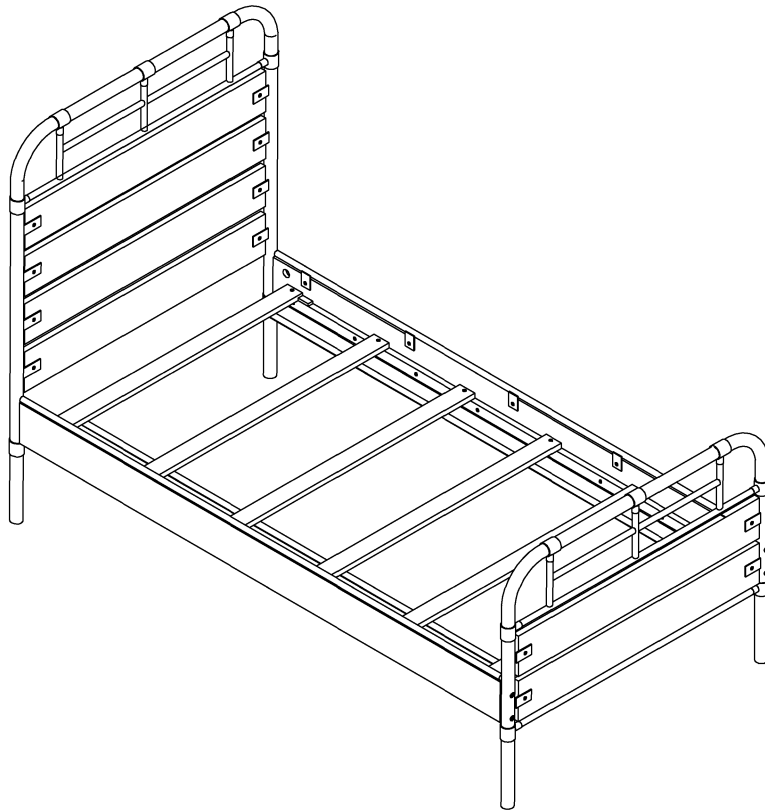

ASSEMBLY IS COMPLETED