

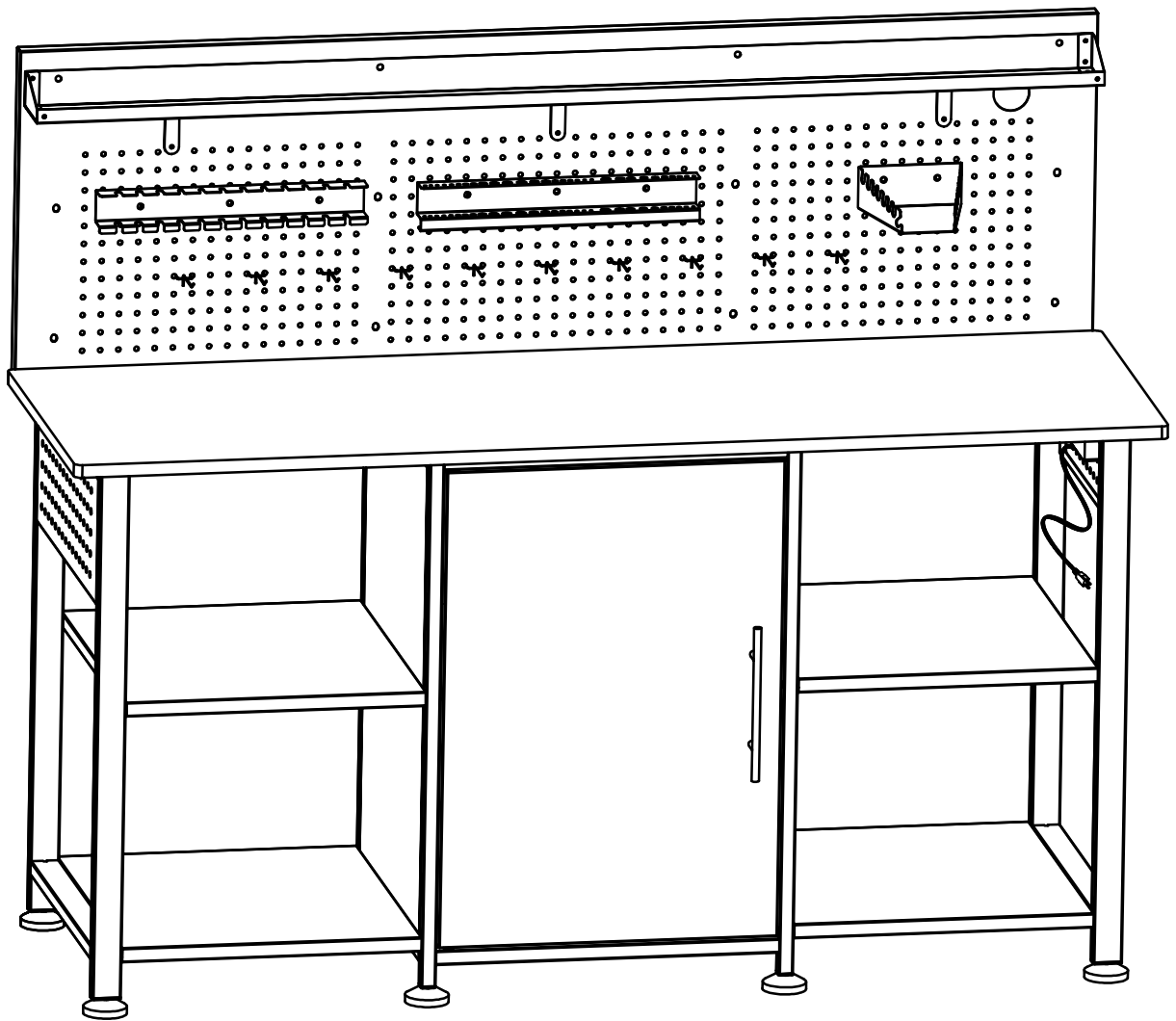











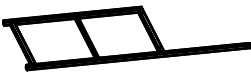
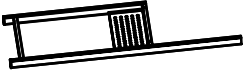

# Installation Manual









## Work Bench

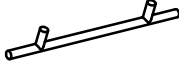

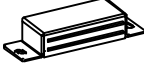













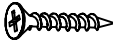

# Parts List





Number	Parts	Quantity
1		1PC
2		1PC
3		4PCS
4		1PC
5		1PC
6		1PC
7		1PC
8		1PC
9		4PCS
10		1PC
11		1PC
12		1PC
13		1PC
14		1PC
15		3PCS

Number	Parts	Quantity
16		1PC
17		1PC
18		1PC
19		5PCS 5PCS
20		2PCS
21		8PCS
22		1PC
23		1PC
24		1PC
26		1PC

Number	Parts	Quantity
A	 M6x55	12PCS
B	 M6x35	8PCS
C	 M6x35	12PCS
D	 M6x12	28PCS
E	 M4x8	16PCS
F	 M6	1PC
G	 M6	8PCS
H	 M4x16	7PCS
I		2PCS
J	 M4	13PCS
K	 M4x12	8PCS
L	 M4	1PC
M	 M8x35	8PCS
N	 M8x20	8PCS
O	 M8	1PC
P	 M10	1PC



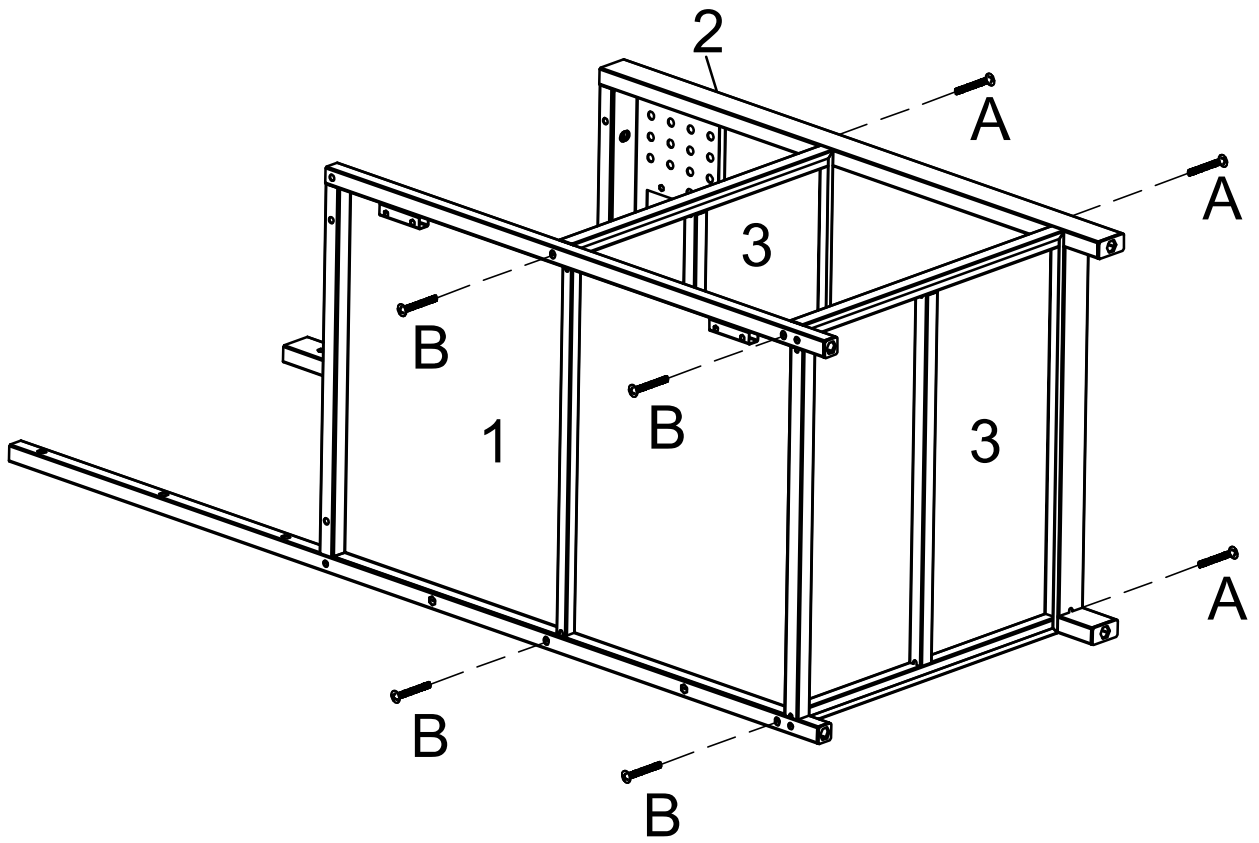

Note: This product is recommended for installation by two people

# Step 1

	A x 4
	B x 4
	1 x 1
	2 x 1
	3 x 2



# Step 2

	A x 4
	B x 4
	4 x 1
	5 x 1
	3 x 2

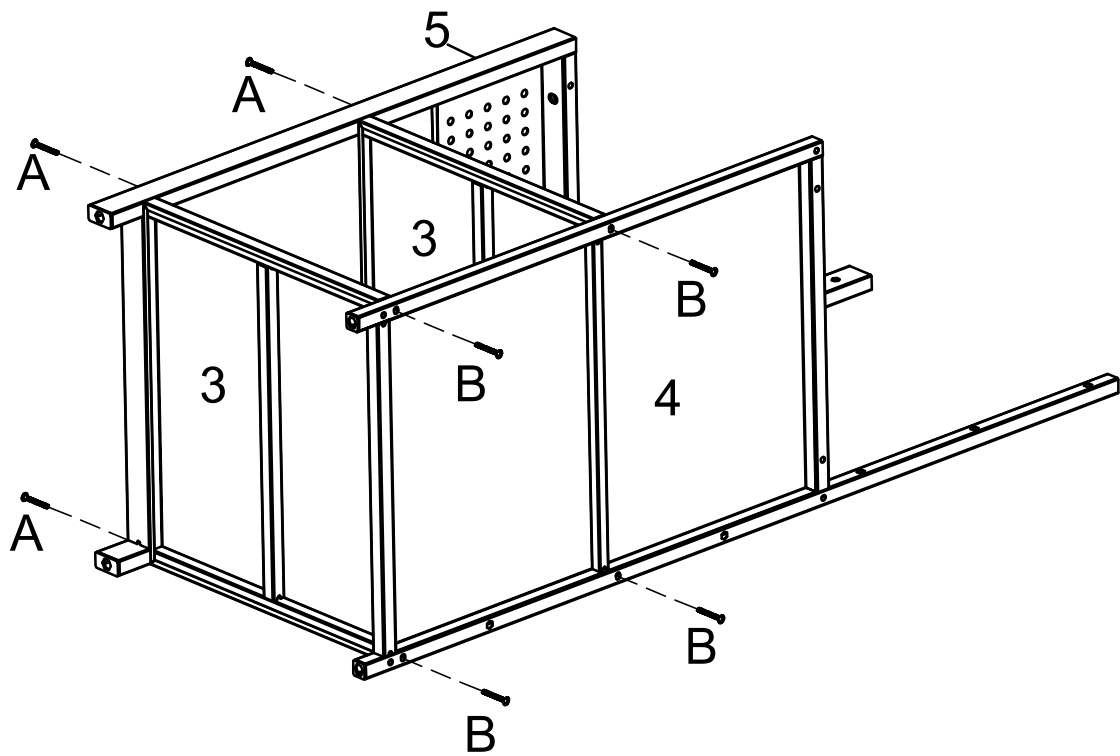

# Step 3



C x 4



6 x 1

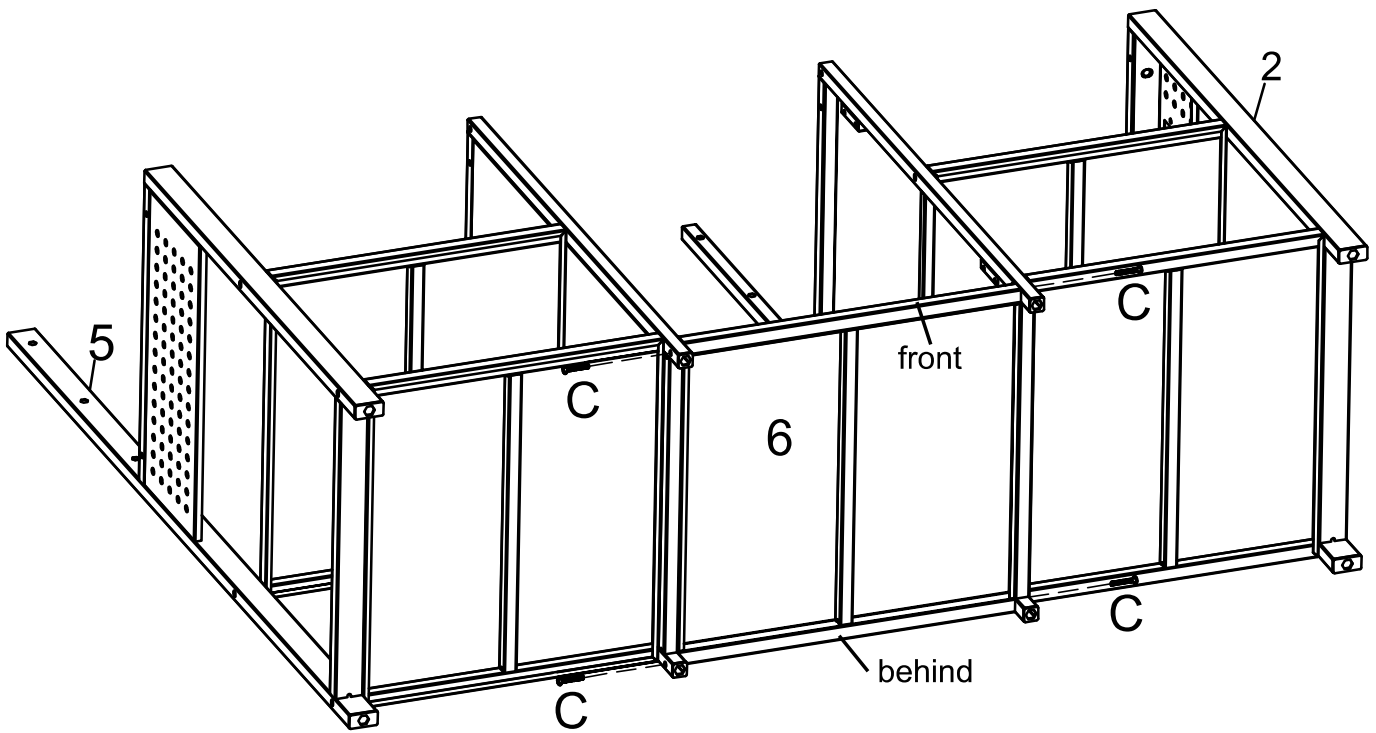
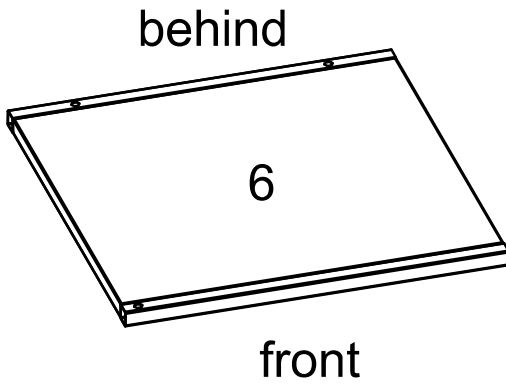

# Step 4



21 x 8





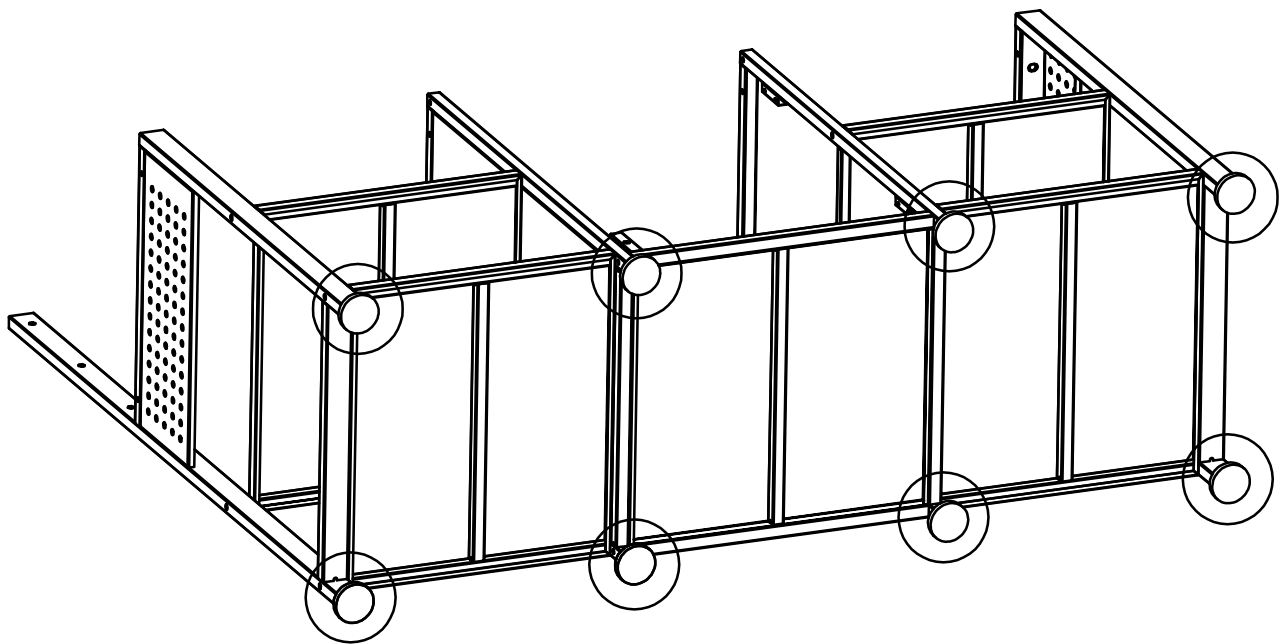
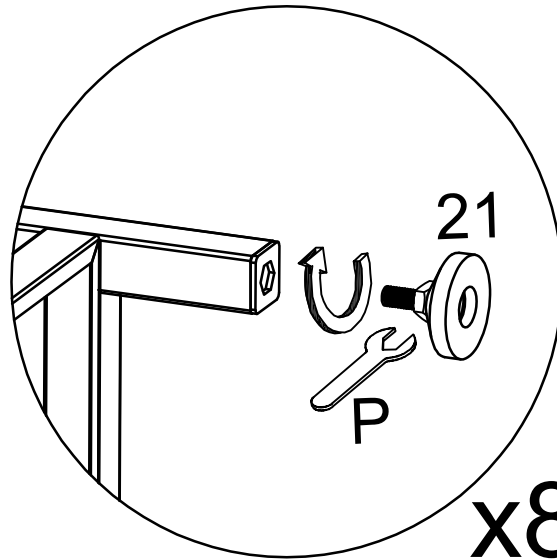

P x 1



Note: In the event of an uneven floor, the tabletop may not remain level after installation. To correct this, adjust the height of Part No.21 (the adjustable foot) until the product is stable. After adjustment, use Part P to tighten the nut on Part No.21 to secure the position and ensure maximum stability.

# Step 5

	A x 4
	C x 6
	8 x 1
	9 x 4

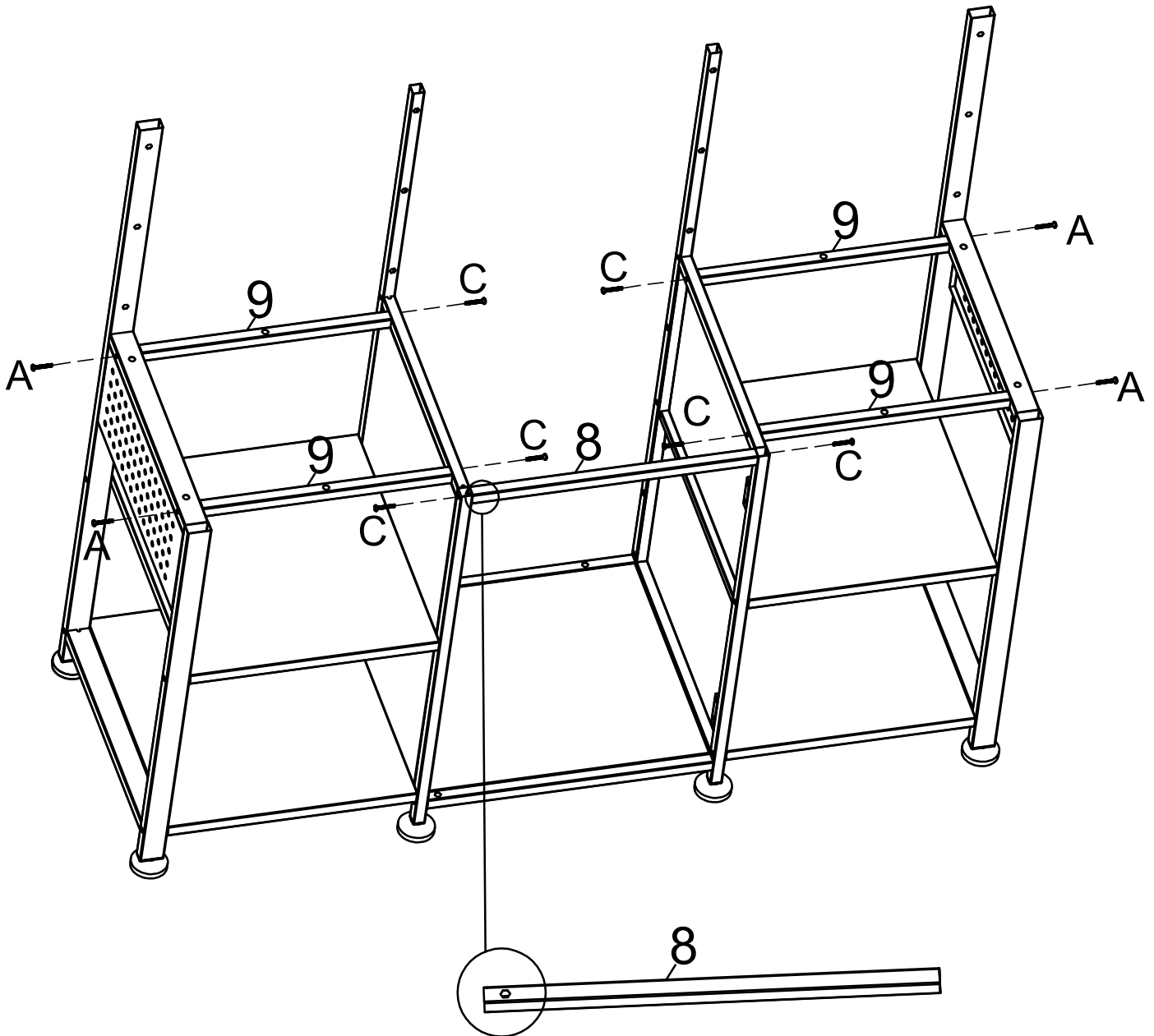

Note: Please note that when installing NO.8 part, the perforated part should be placed with the perforations facing downwards on the left side.

# Step 6



D x 6



10 x 1

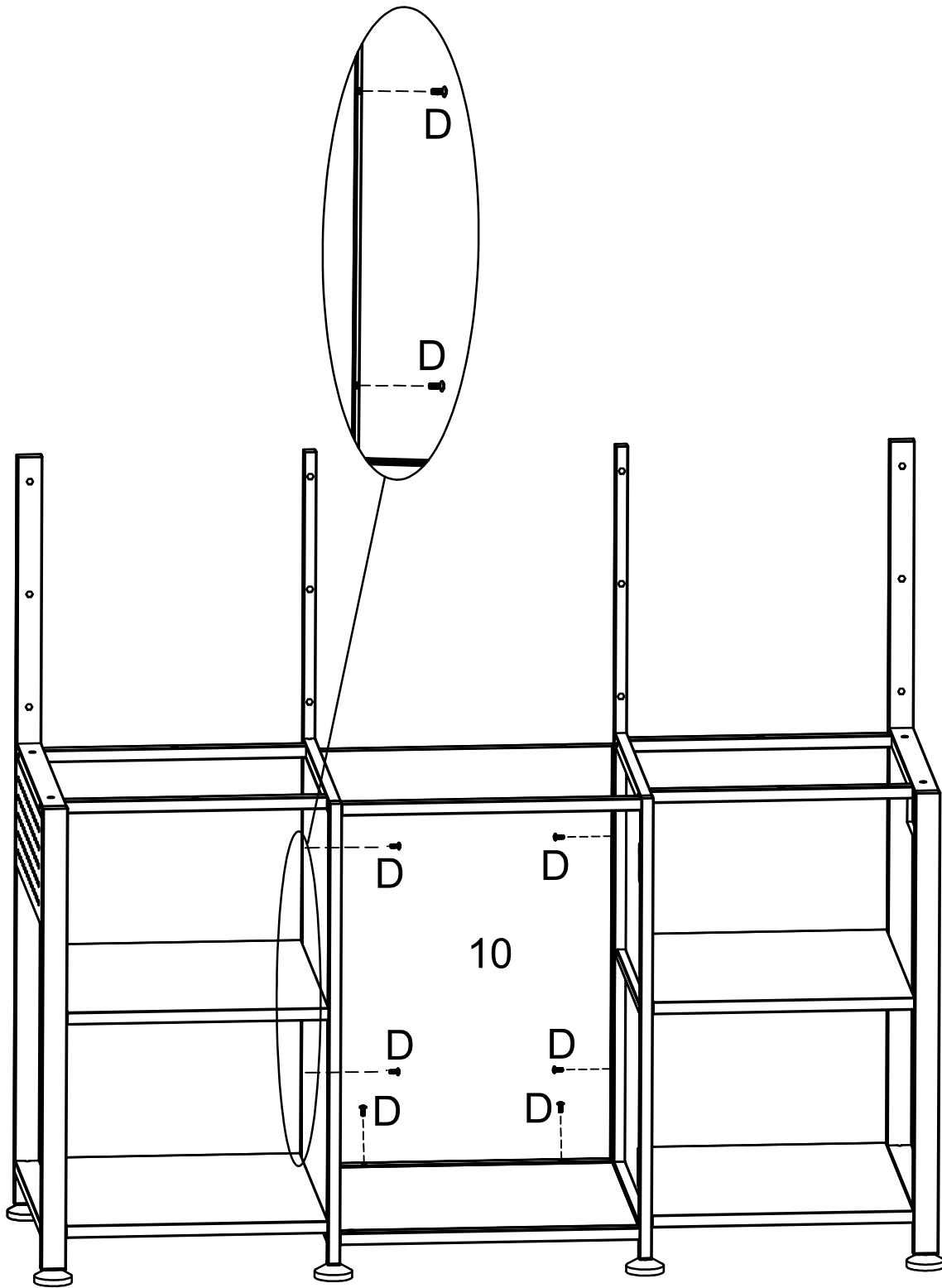

# Step 7



C x 2



12 x 1

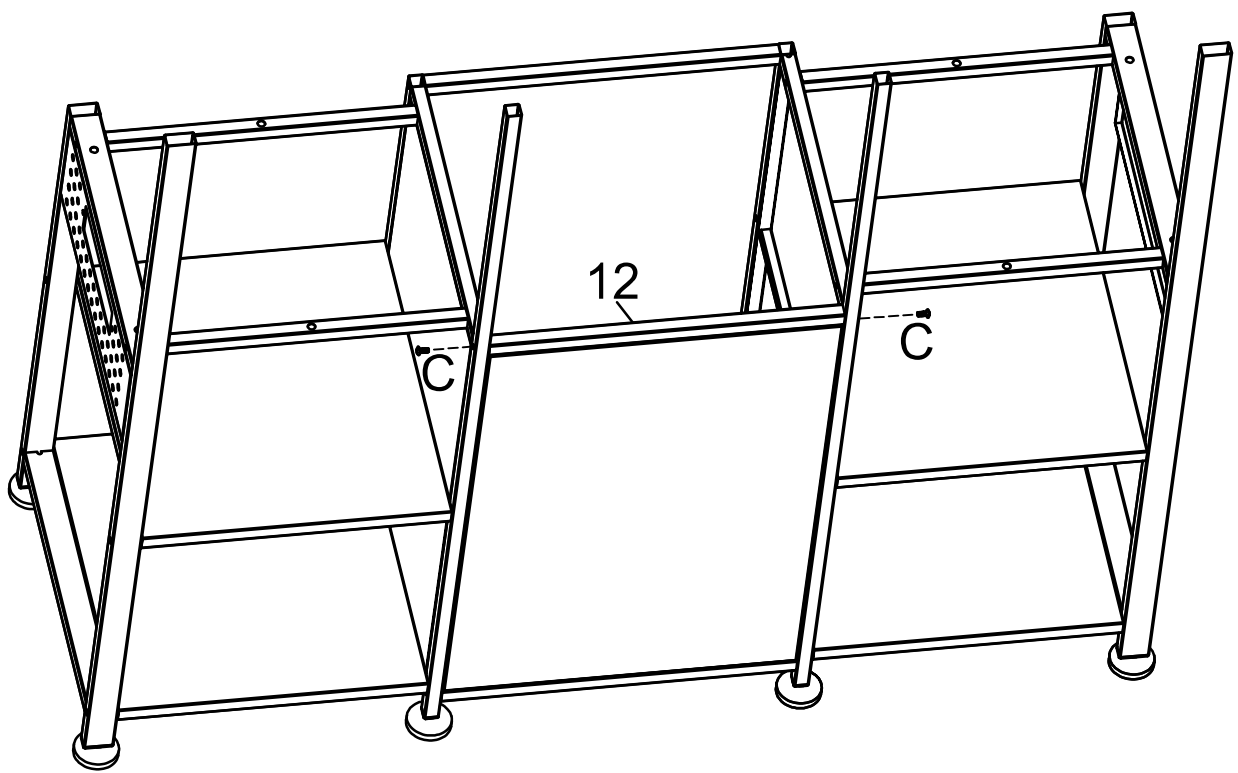

# Step 8



D x 2

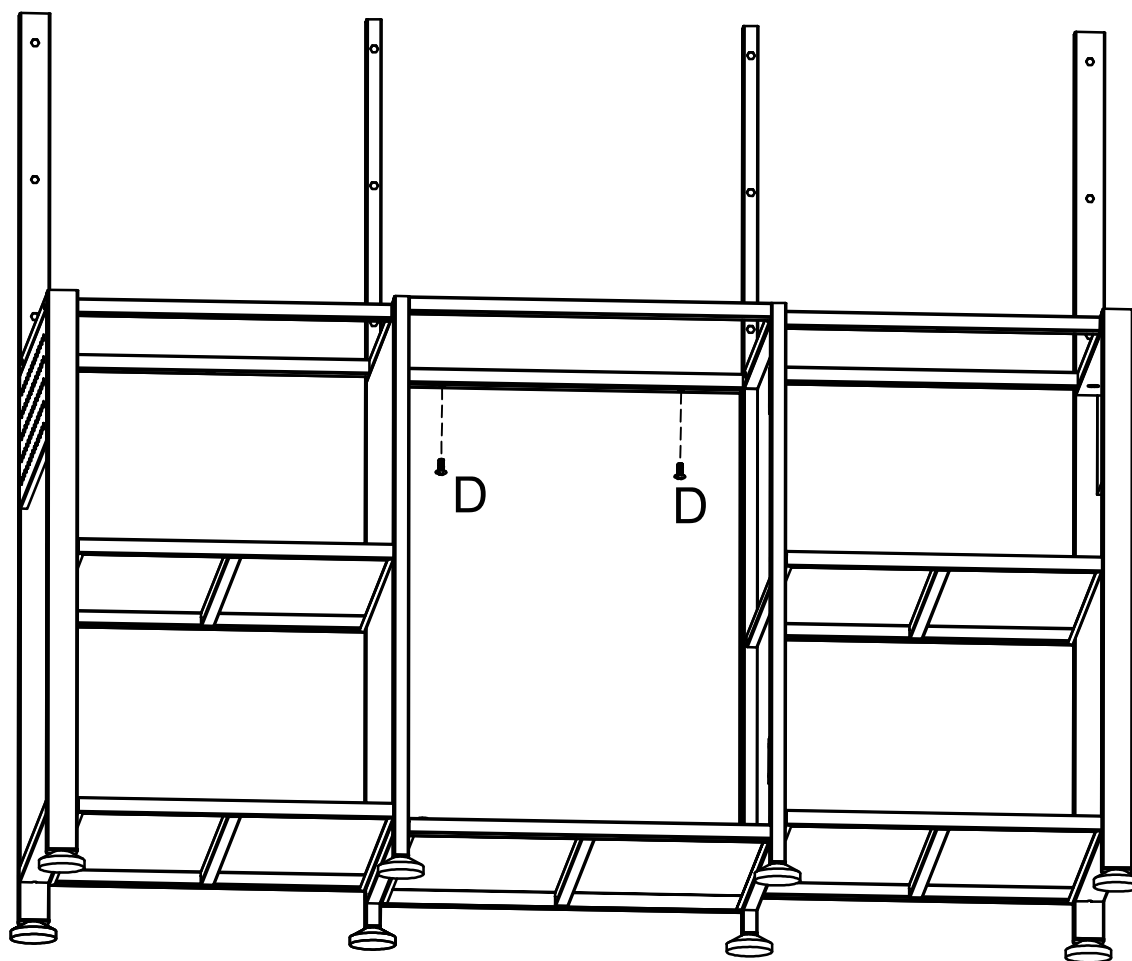

# Step 9

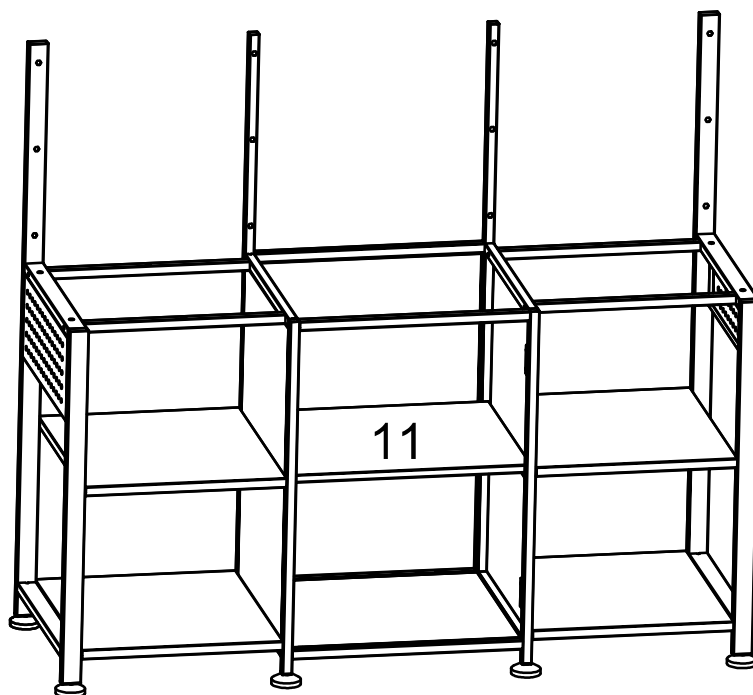
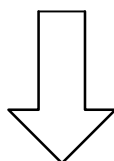
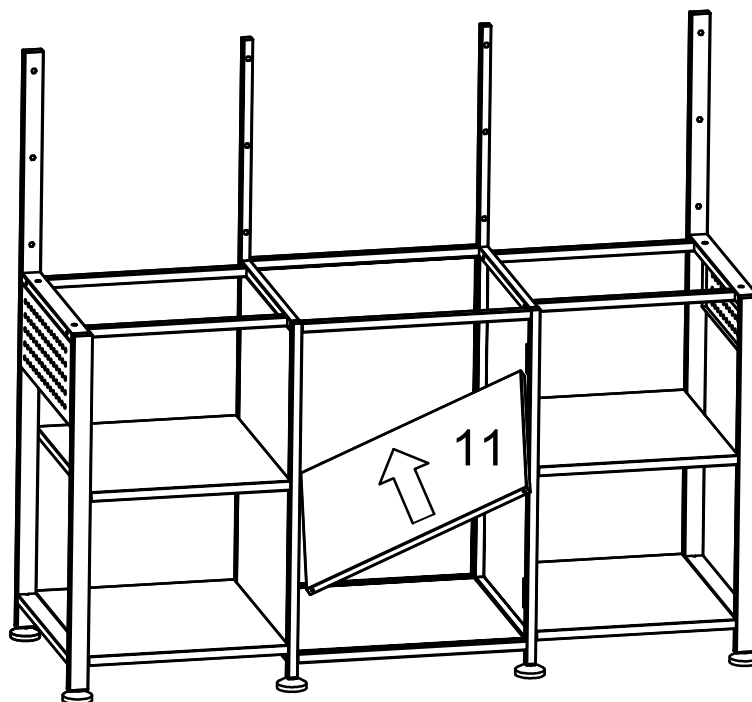
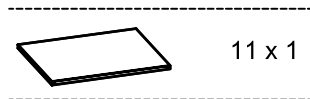

# Step 10



E x 4



20 x 2

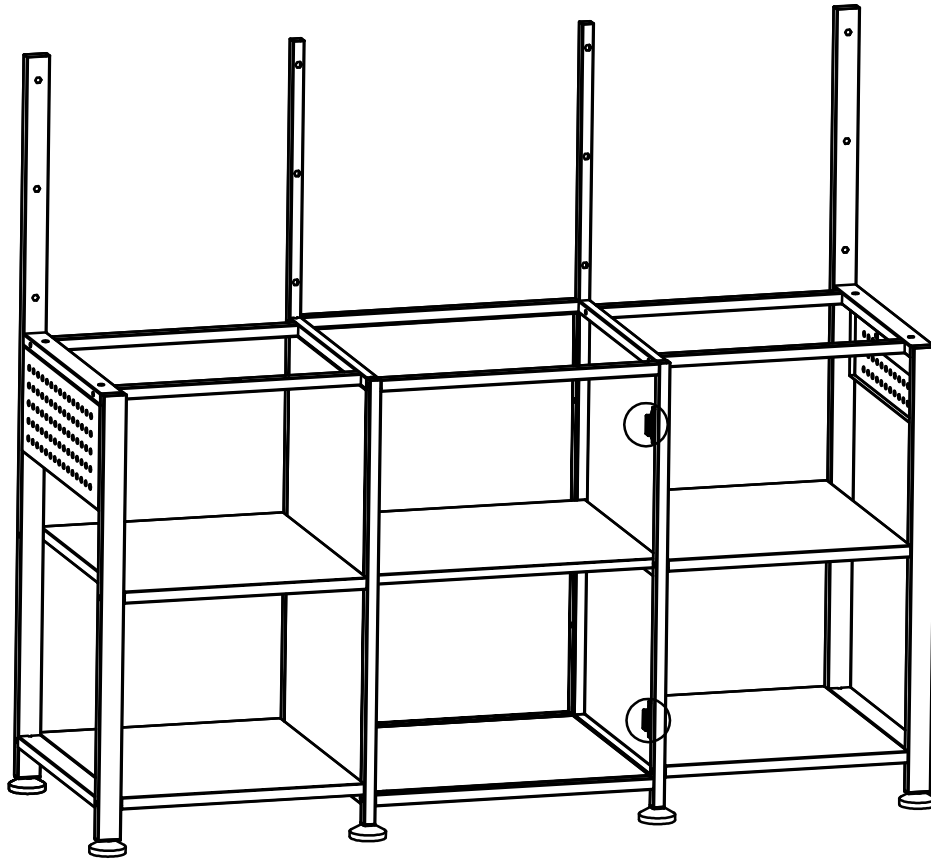

After installation,  
remove the metal  
gasket

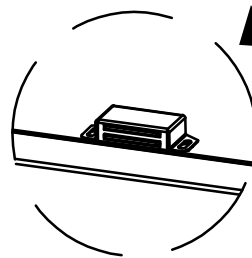
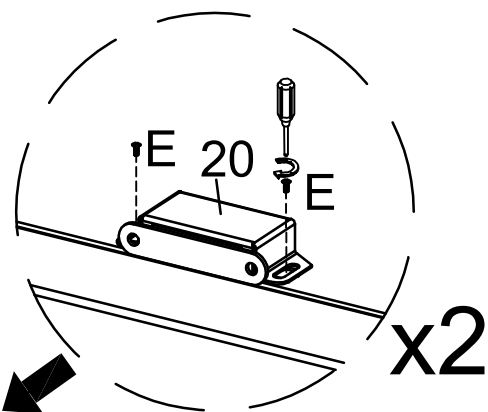

# Step 11



E x 2



7 x 1



17 x 1

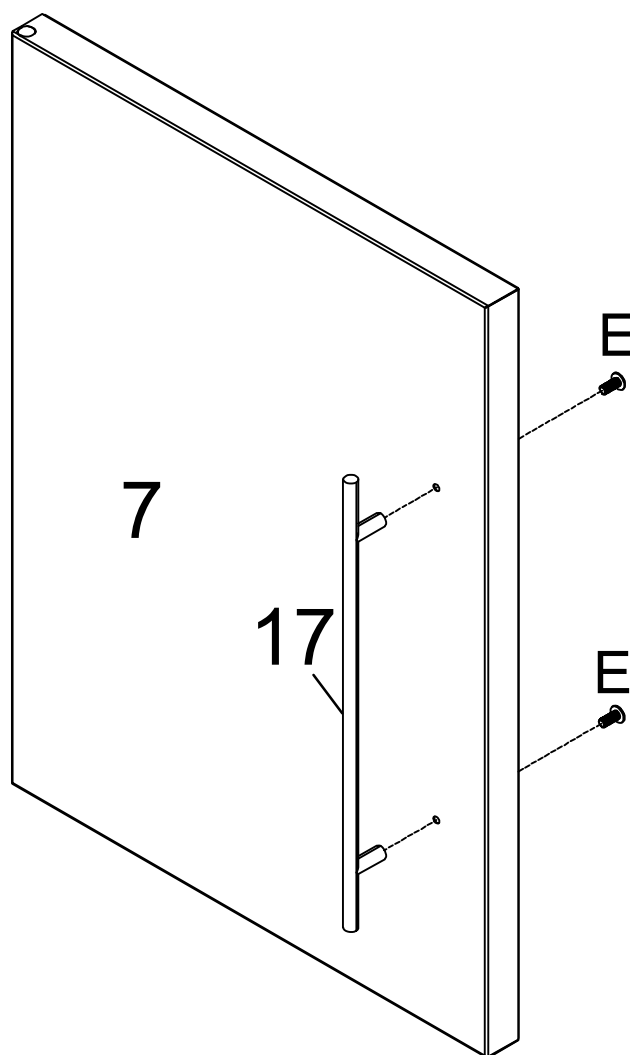

# Step 12



1 x 2

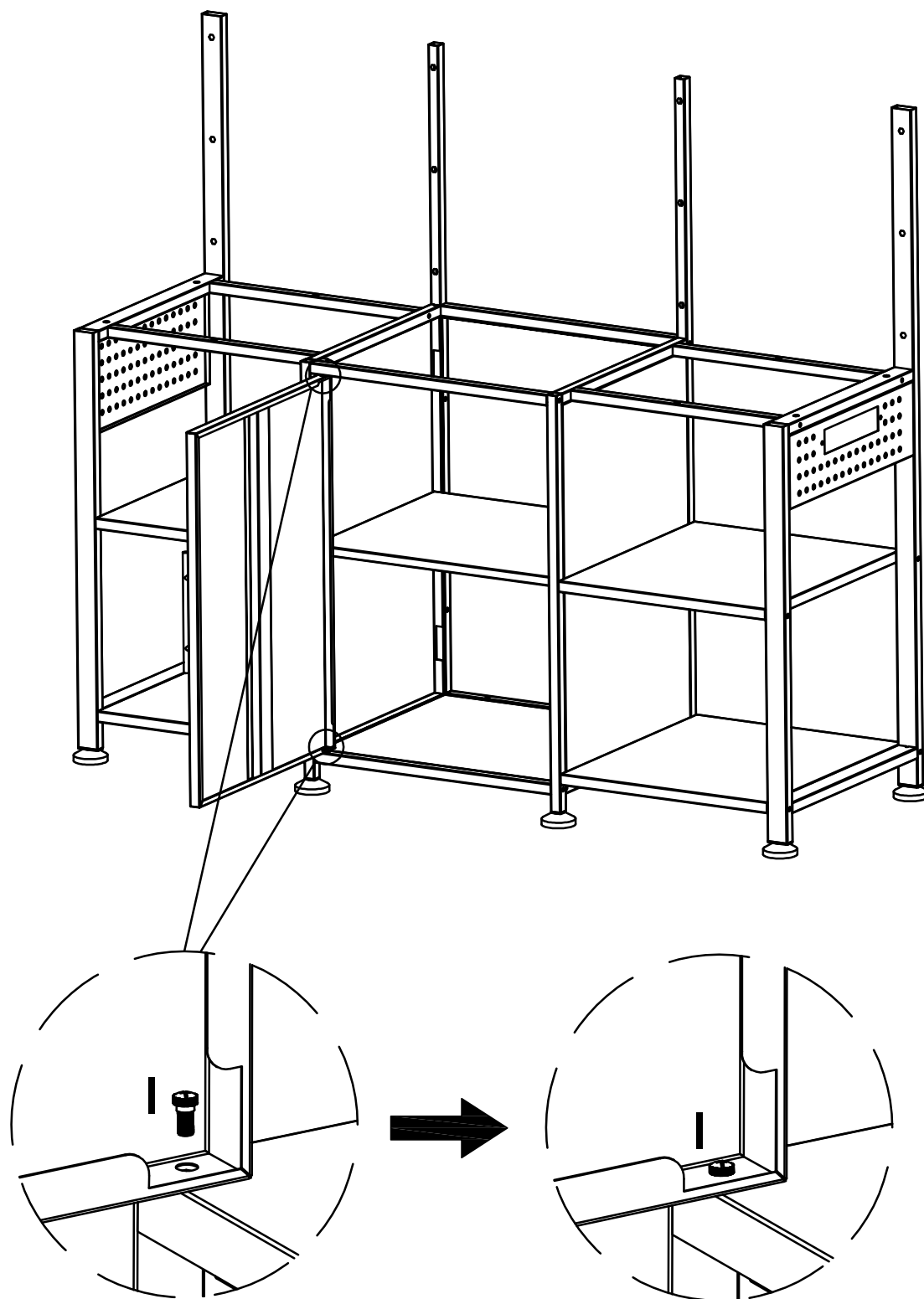

# Step 13







D x 8

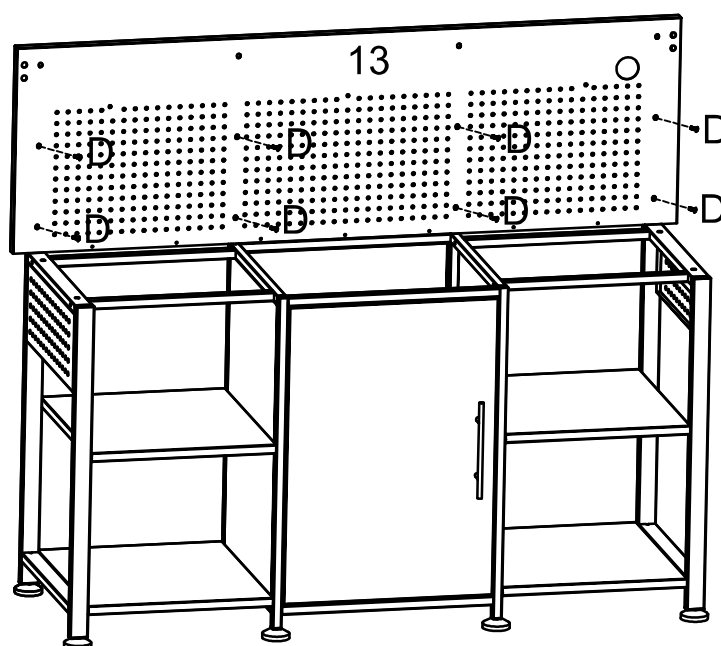
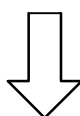
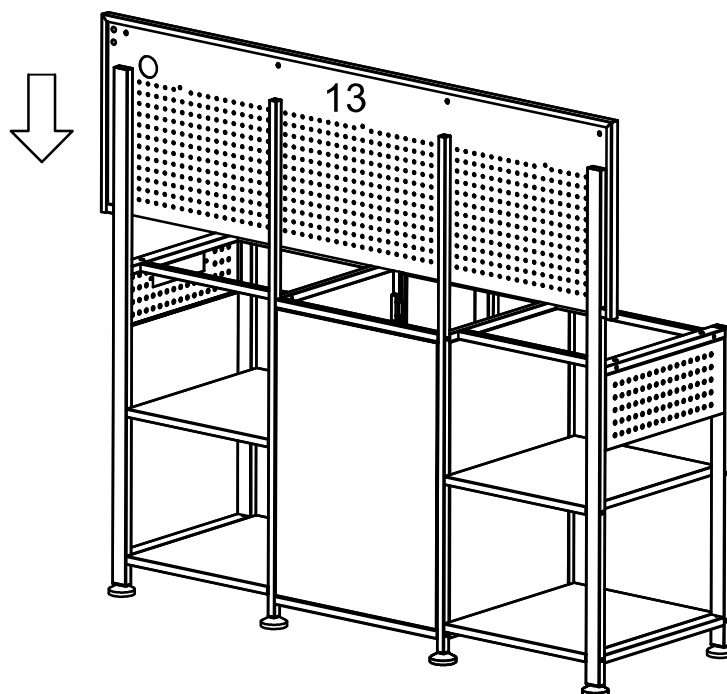

13 x 1





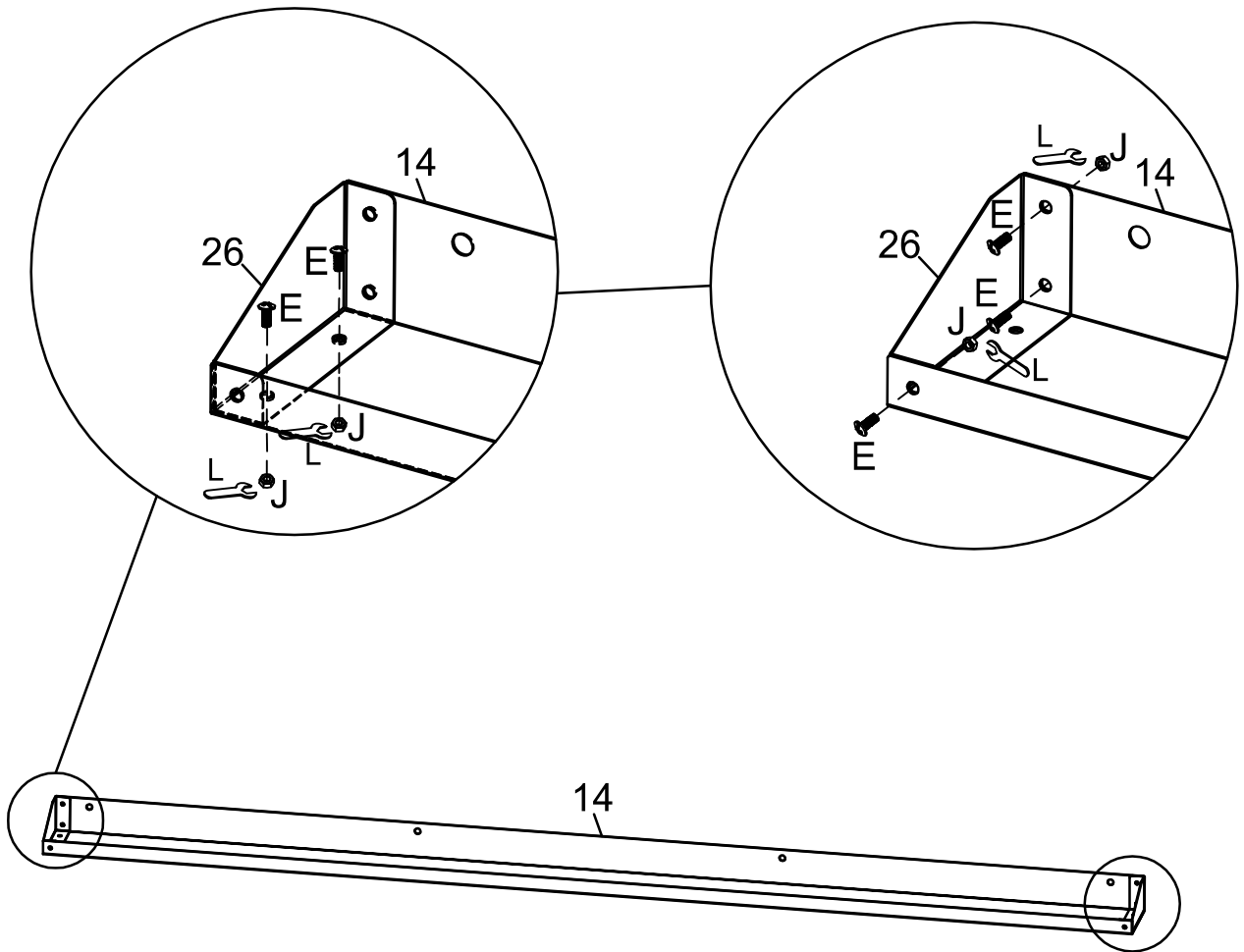

# Step 14

	E x 10
	J x 10
	14 x 1
	26 x 1
	L x 1



# Step 15

	D x 4
	K x 6
	J x 3
	15 x 3
	L x 1

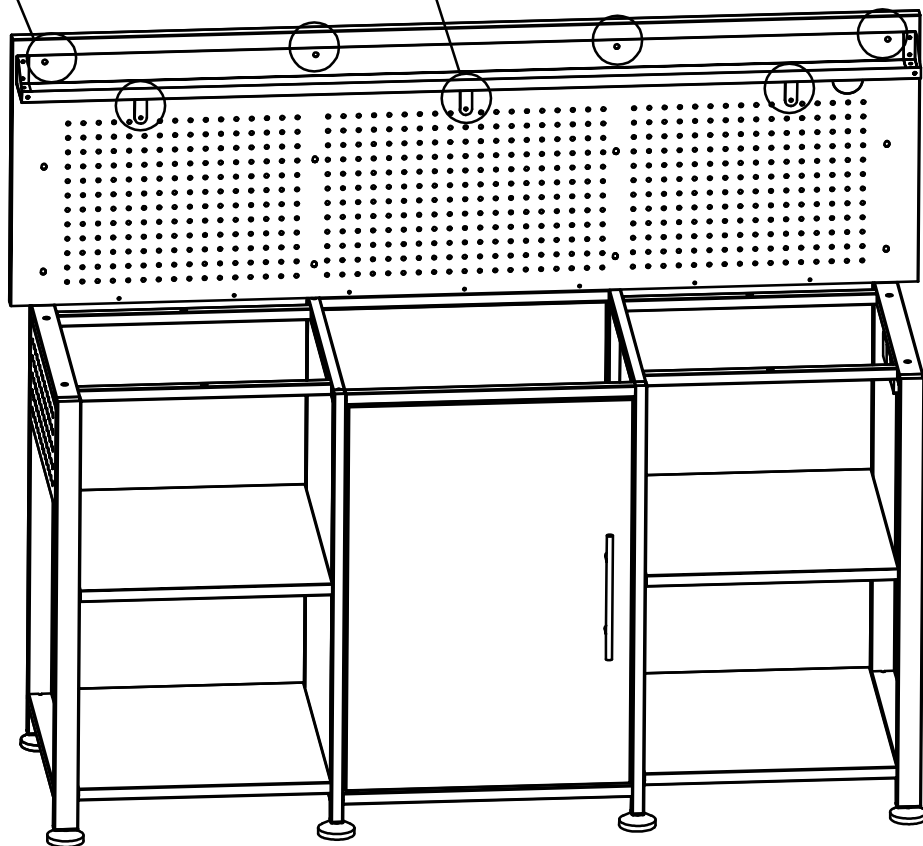
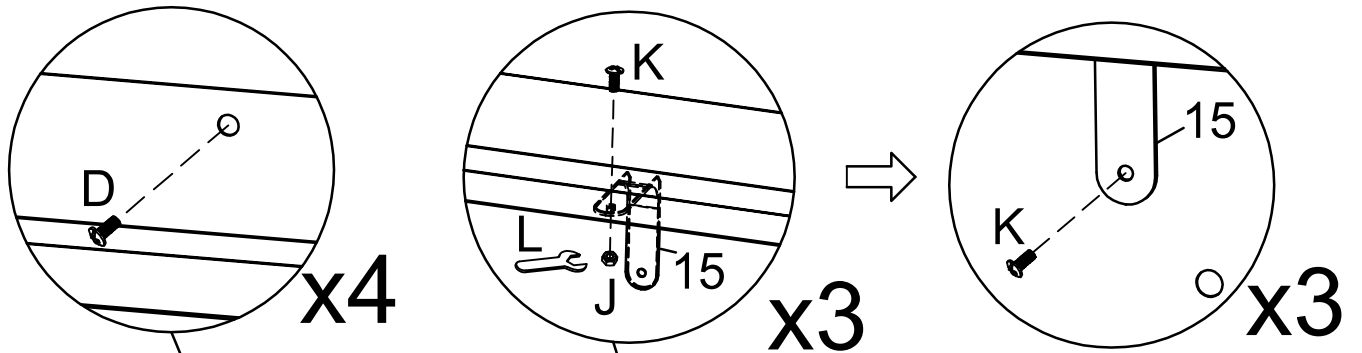

# Step 16

 M x 2

 N x 2

 O x 1

 16 x 1

Note: Do not tighten the screws until step 18 is complete!

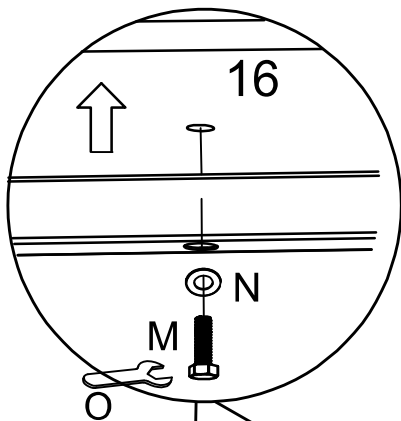

Tips : During installation, you can slightly lift the wooden board of NO.16-Part to check if the hole positions are aligned.

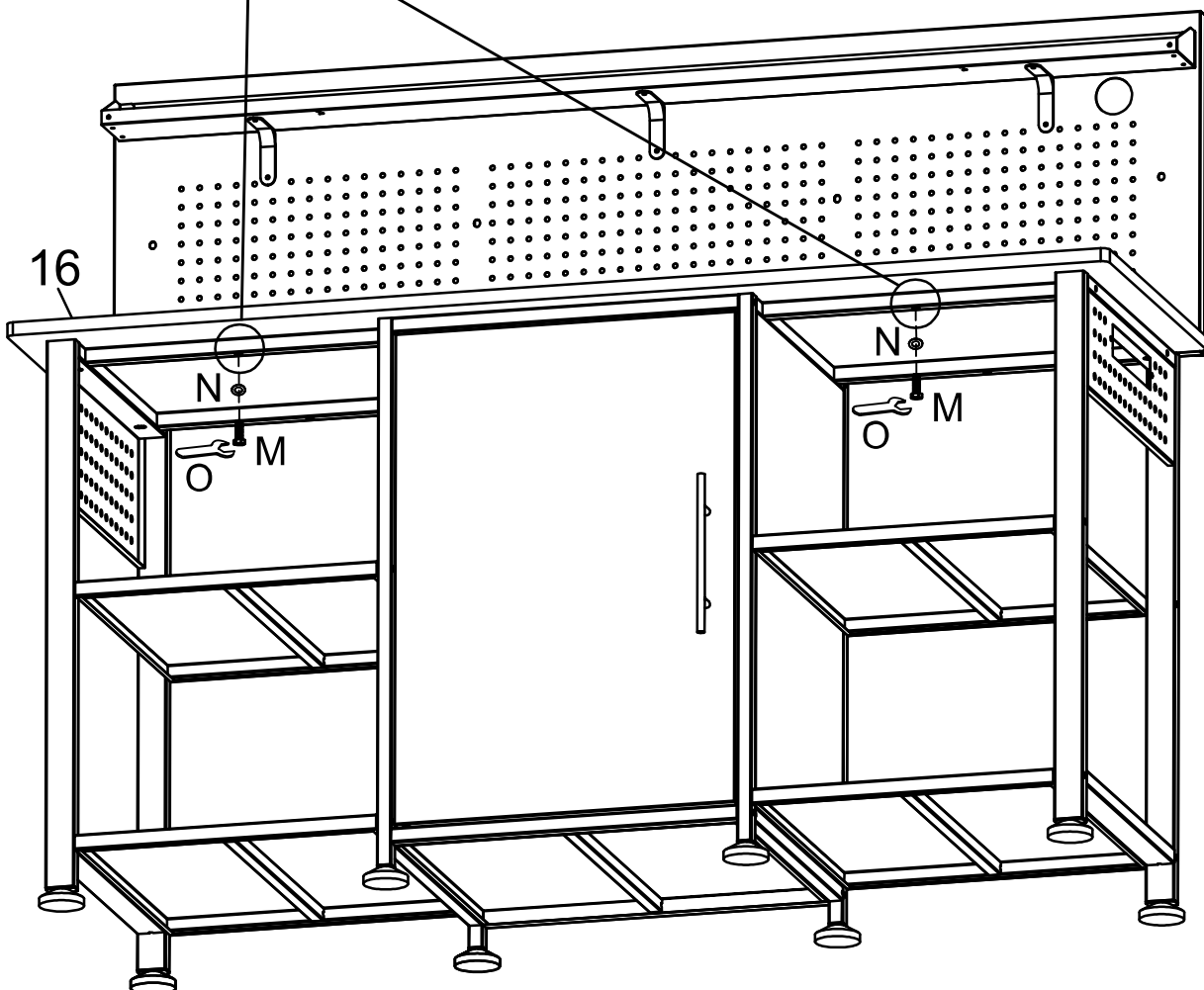

# Step 17



M x 6



N x 6



O x 1

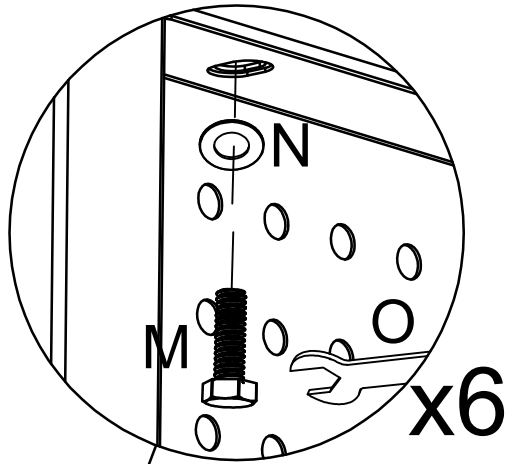

Note: Do not tighten the screws until step 18 is complete

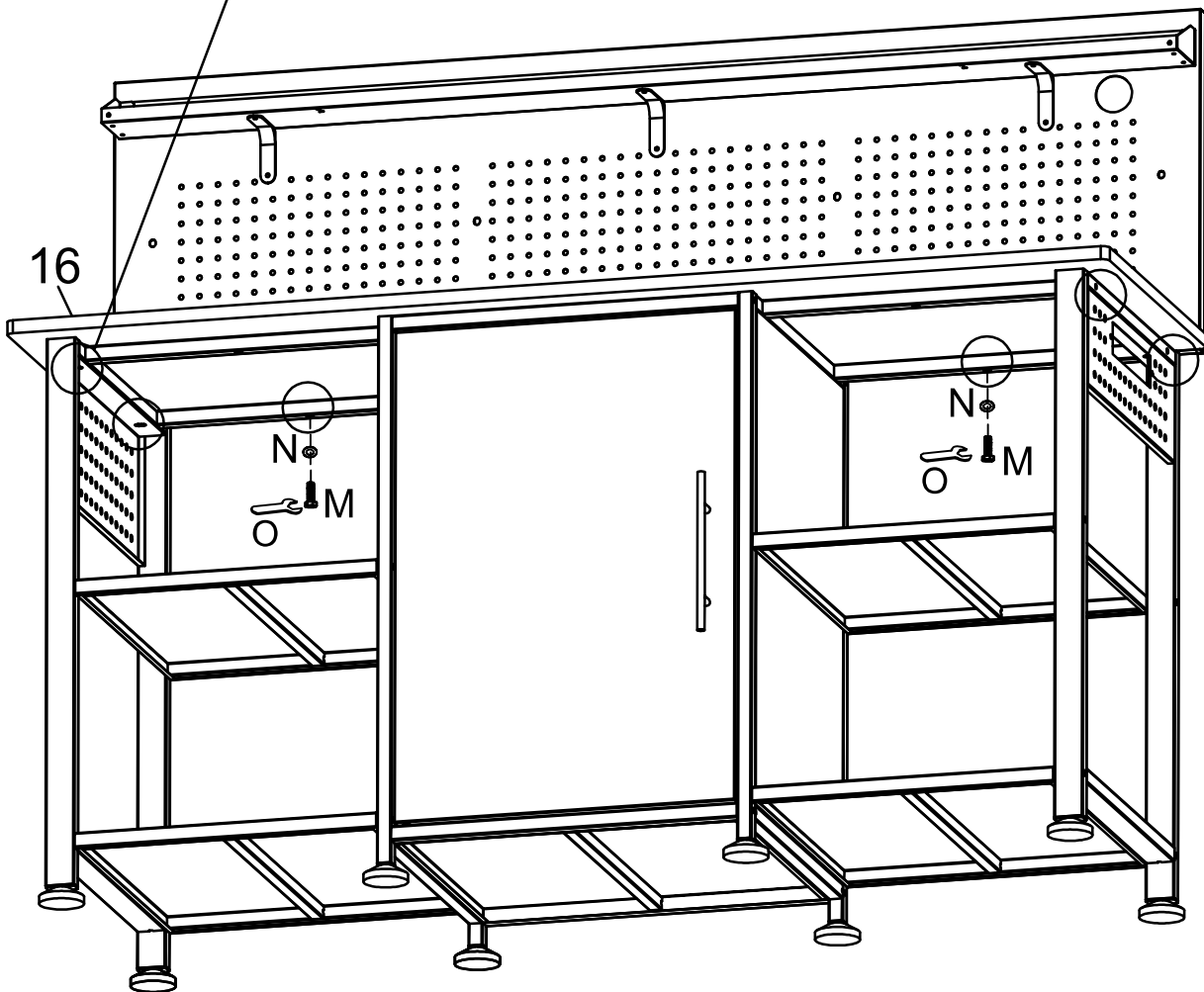

# Step 18

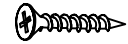

H x 7

Attention: Please tighten **all** screws that were not tightened in steps 16 and 17

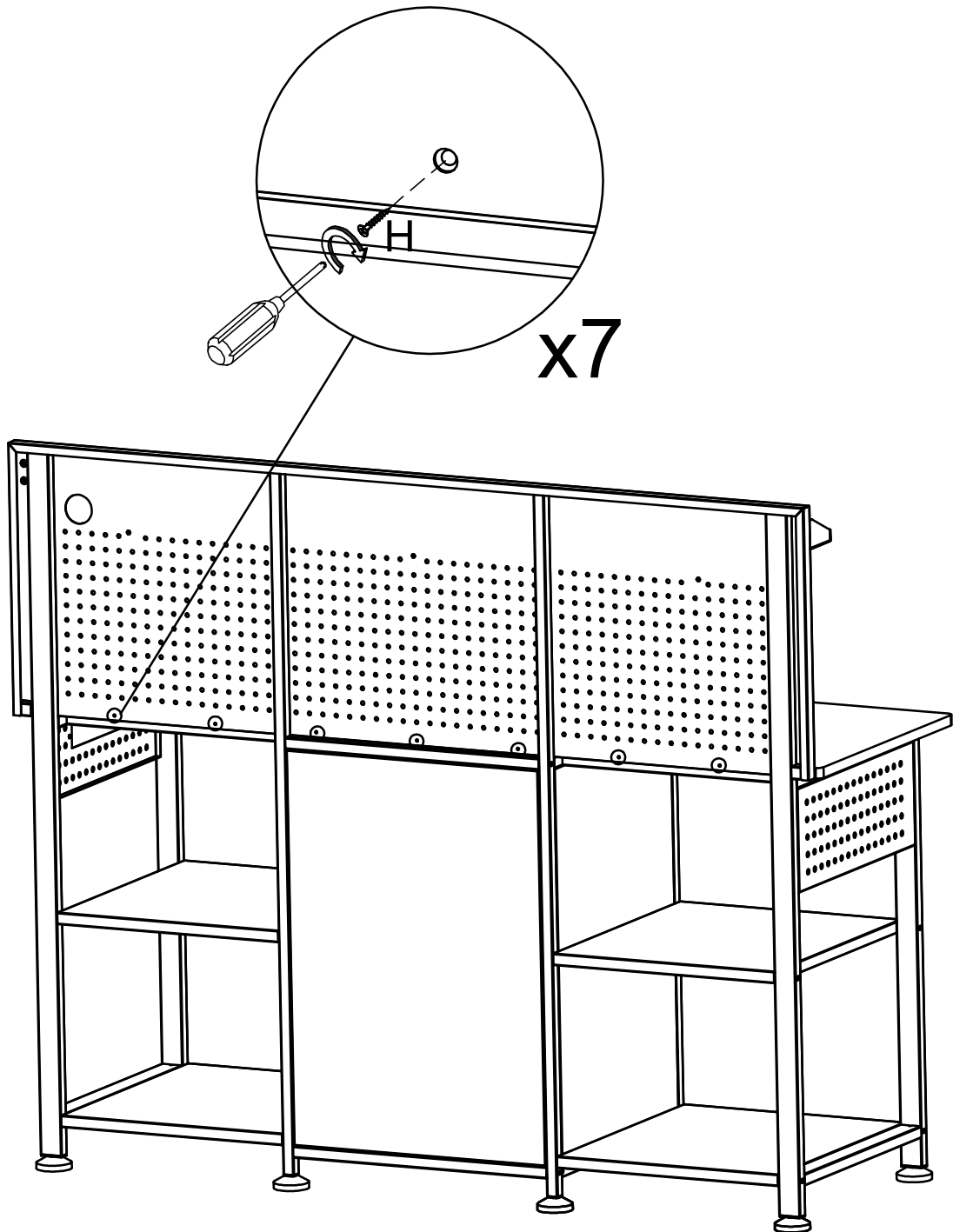

# Step 19

 18 x 1

 K x 2

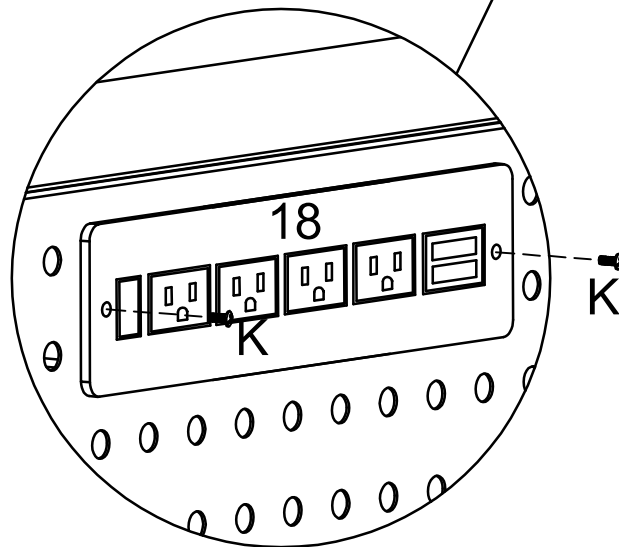
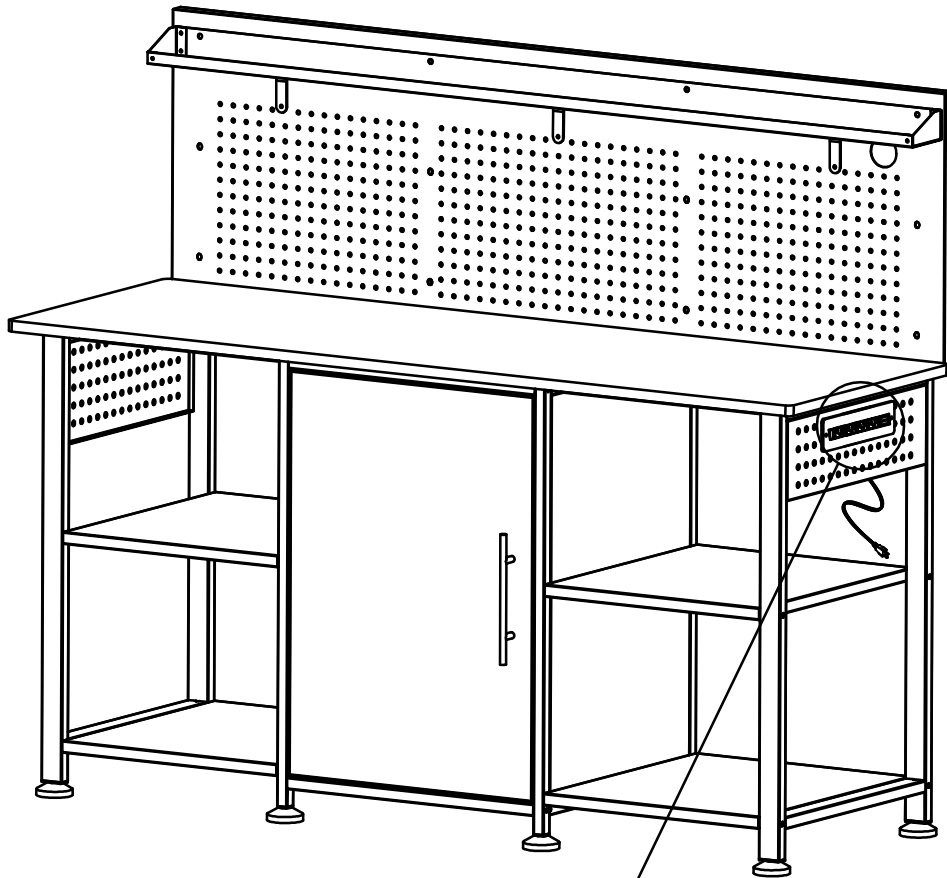

# Step 20







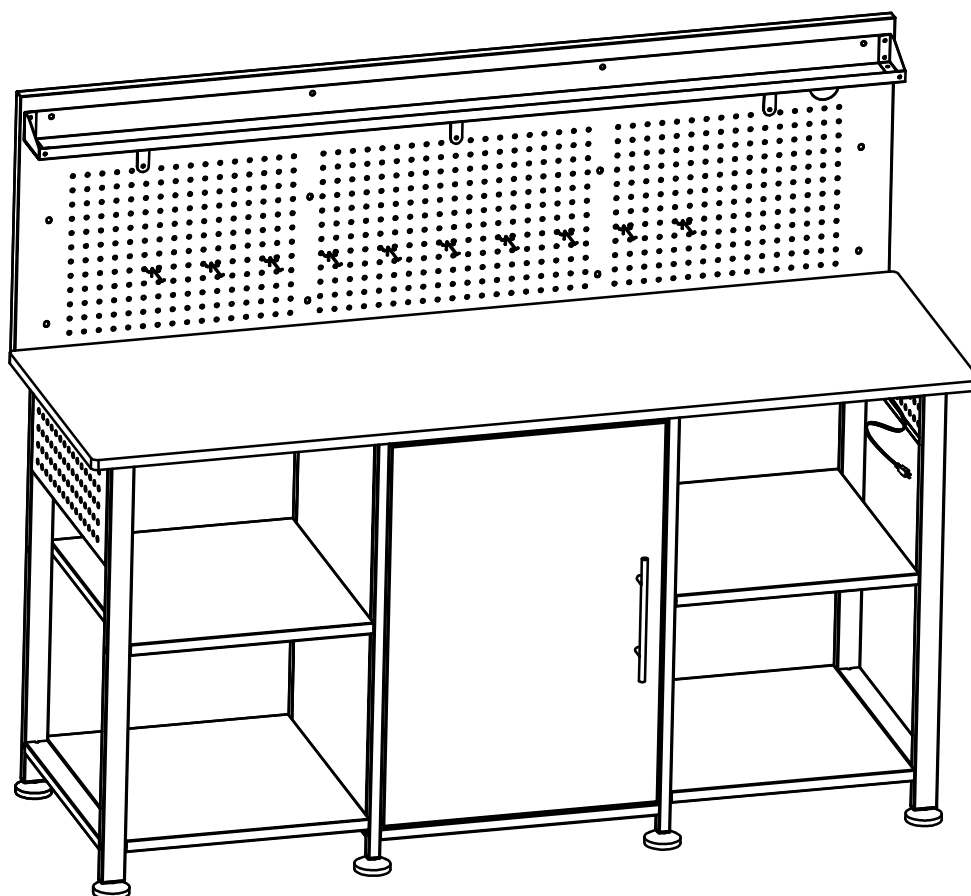
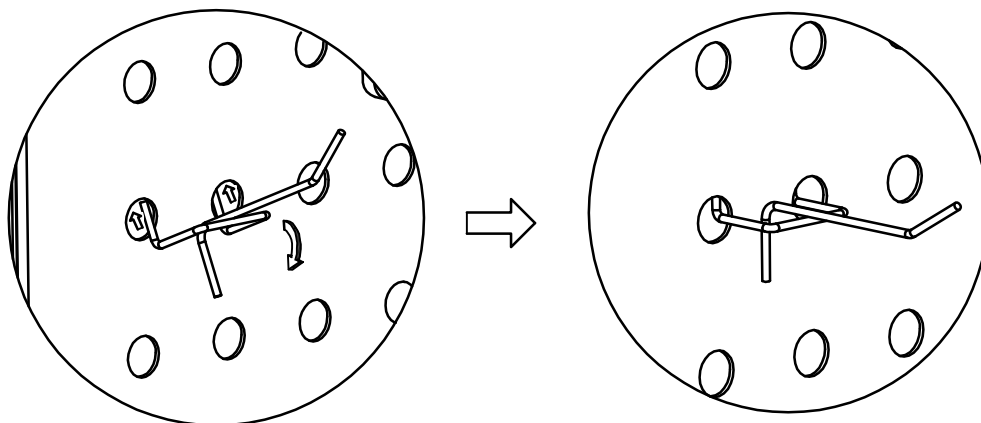

19 x 10

Tips: We have provided sufficient NO.19 parts. Please choose and use them according to your requirements



# Step 21

Tips: Please choose and use NO.22 , NO.23 , NO.24 Part according to your requirements

	D x 8
	G x 8
	F x 1
	22 x 1
	23 x 1
	24 x 1

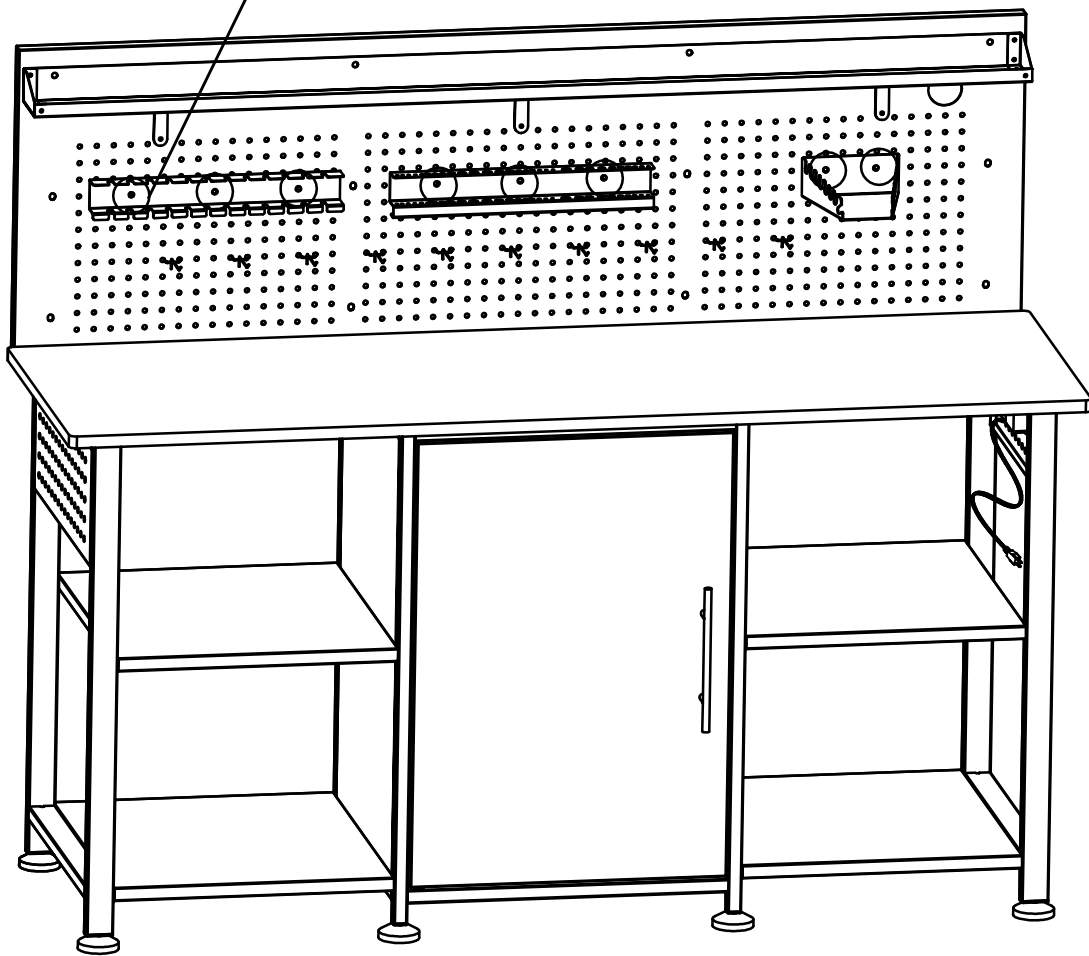
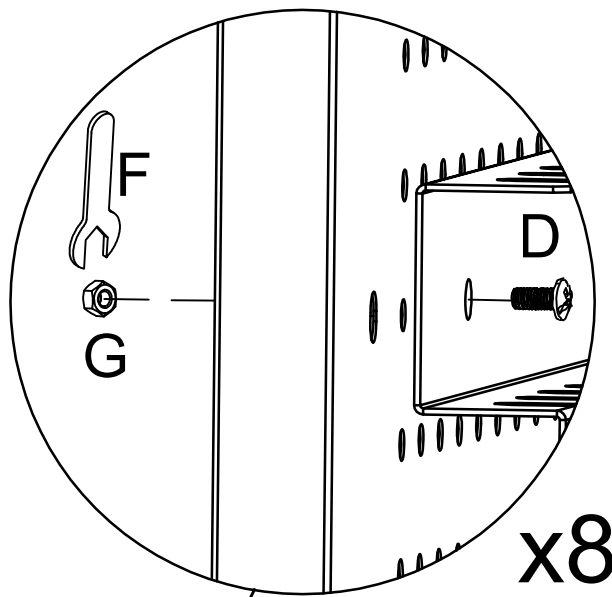

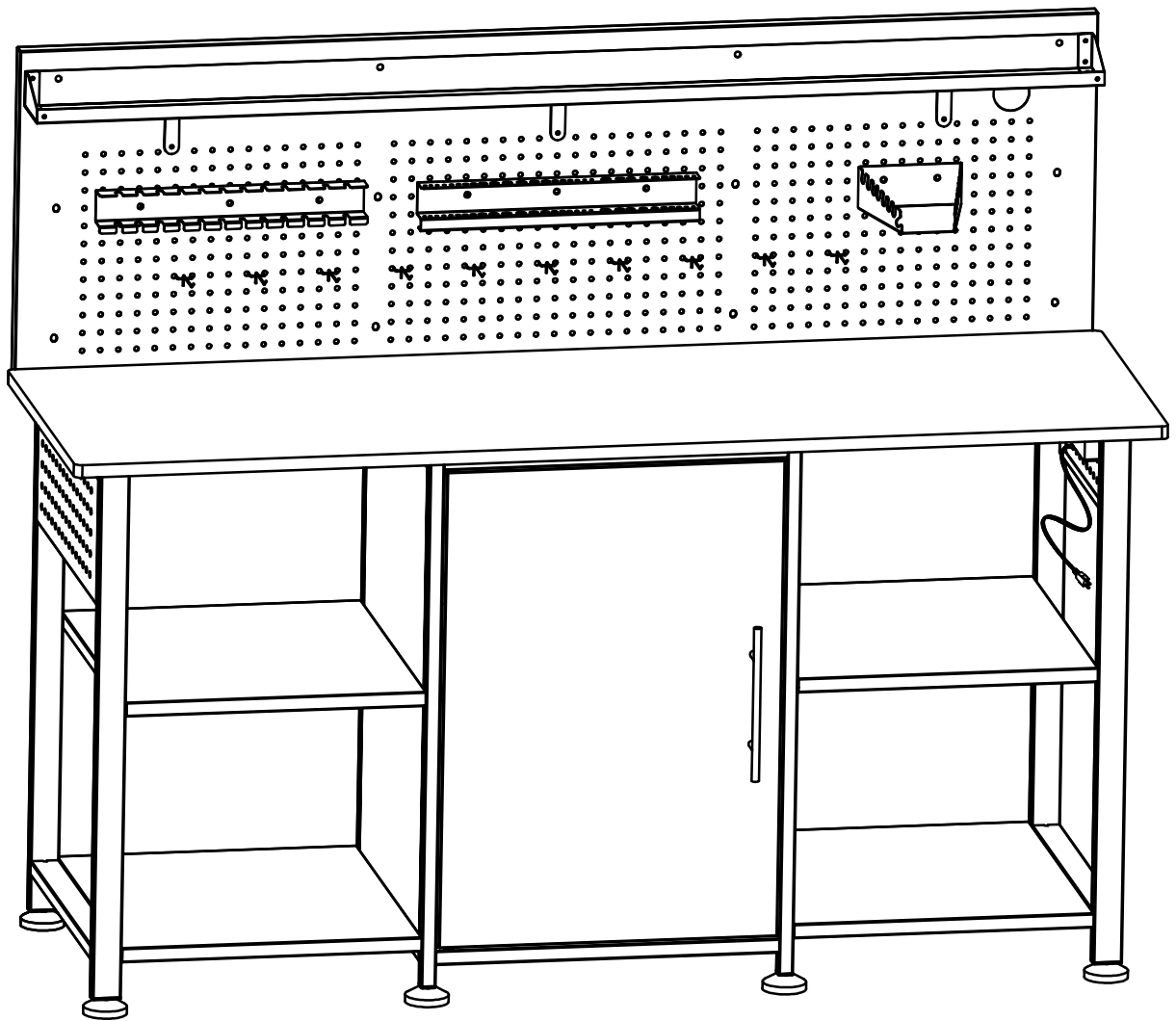

Final Assembly