

**APARADOR 3 PUERTAS - SIDEBOARD 3 DOORS - BUFFET 3 PORTES -
APARADOR 3 PORTAS - BUFFET 3 PORTE - BÜFETT 3 TÜREN - ΜΠΟΥΦΕ 3 ΠΟΡΤΕΣ**

**INSTRUCCIONES DE MONTAJE - ASSEMBLING INSTRUCTIONS - NOTICE DE MONTAGE - INSTRUÇÕES DE MONTAGEM -
ISTRUZIONI DI MONTAGGIO - MONTAGEANLEITUNG - ΟΔΗΓΙΕΣ ΣΥΝΑΡΜΟΛΟΓΗΣΗΣ**

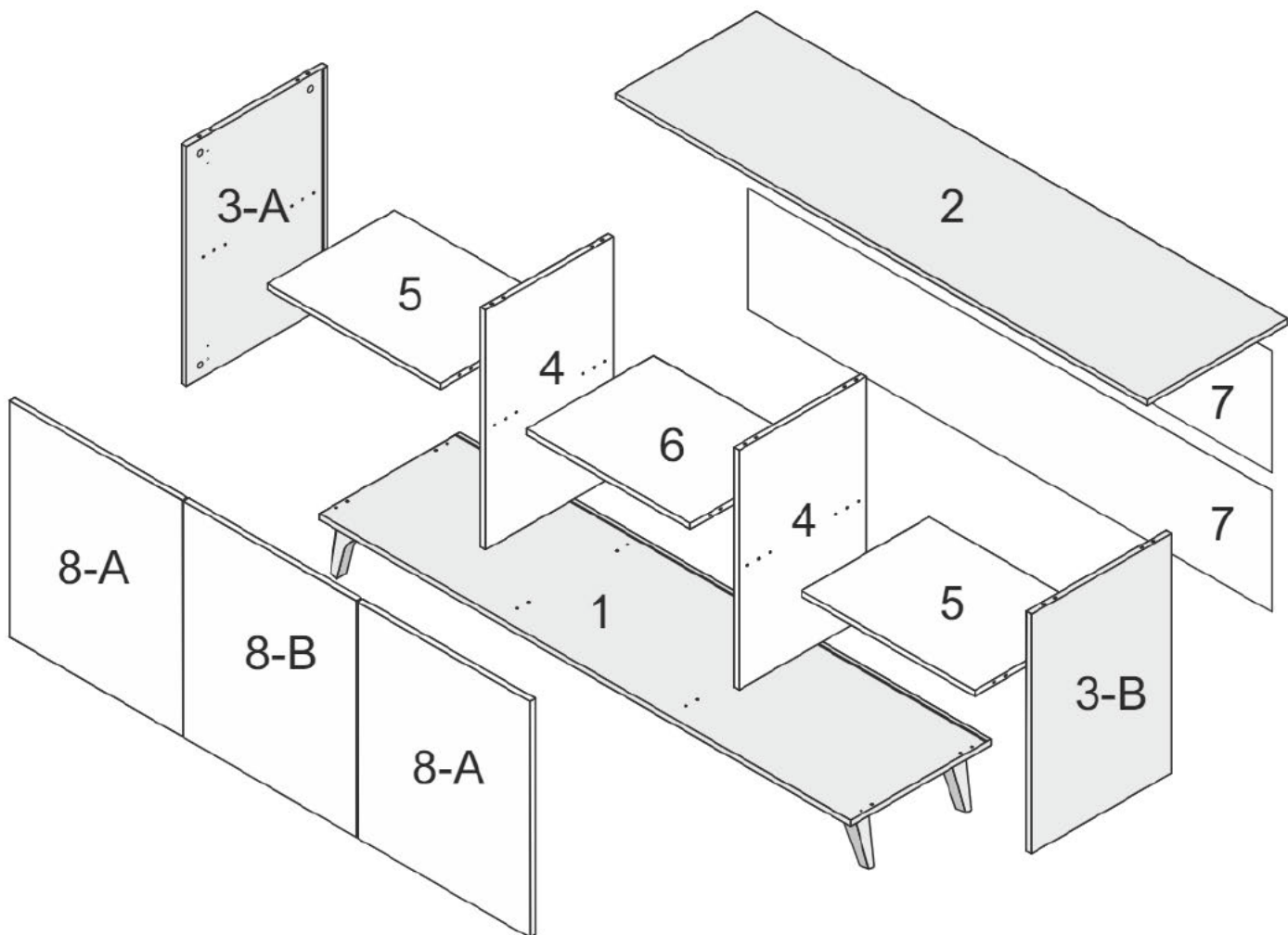

1537 x 400 mm



1537 x 400 mm

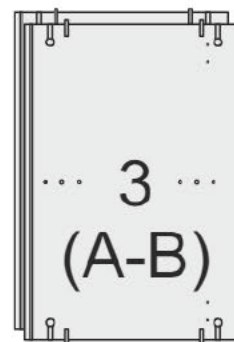

600 x 399 mm



600 x 362 mm

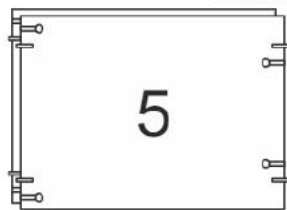

500 x 361 mm

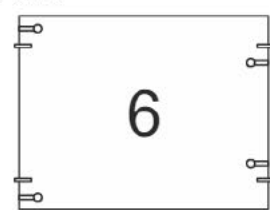

474 x 361 mm

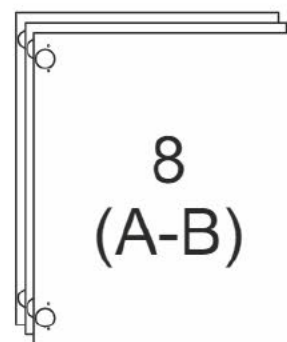

498 x 592 mm



1515 x 304 mm

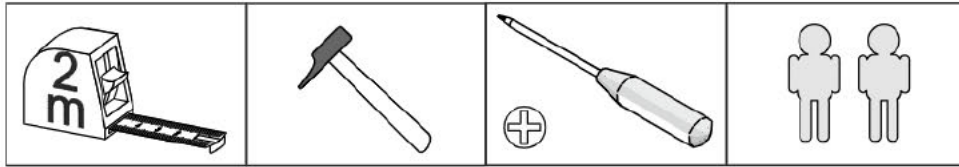

A x 28 6 x 30 mm	B x 4 13 mm	E x 28 3.5 x 16 mm	F x 28 4 x 16 mm
G x 3 15 mm	K x 6 Bracket K	L x 3 Bracket L	N x 10 Bracket N
P x 16 15 mm	Q x 8 20 mm	W x 5 Bracket W	X x 1 n° 4

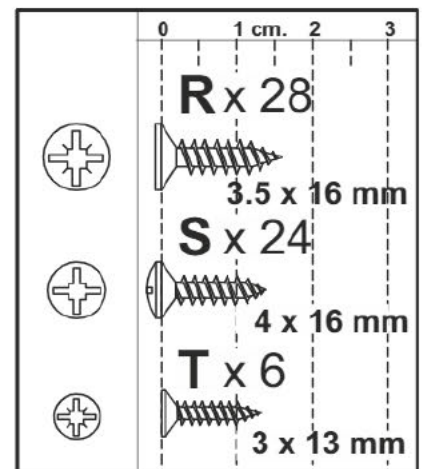
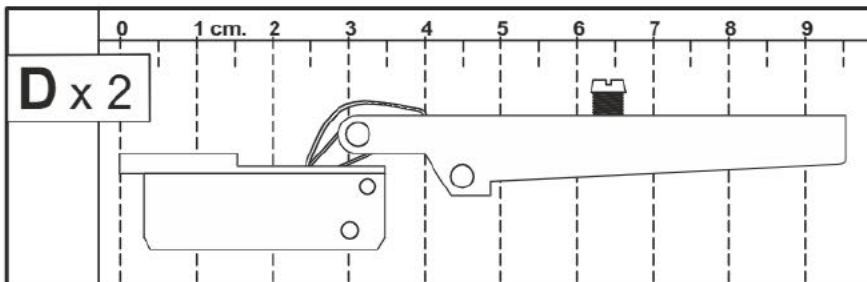
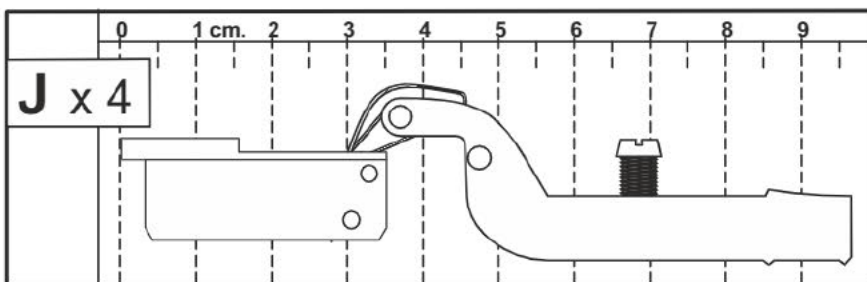

1

180°

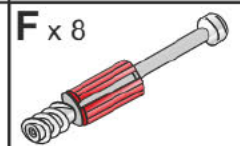
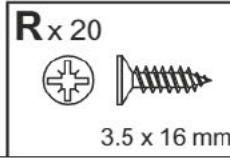
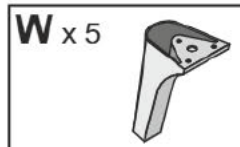
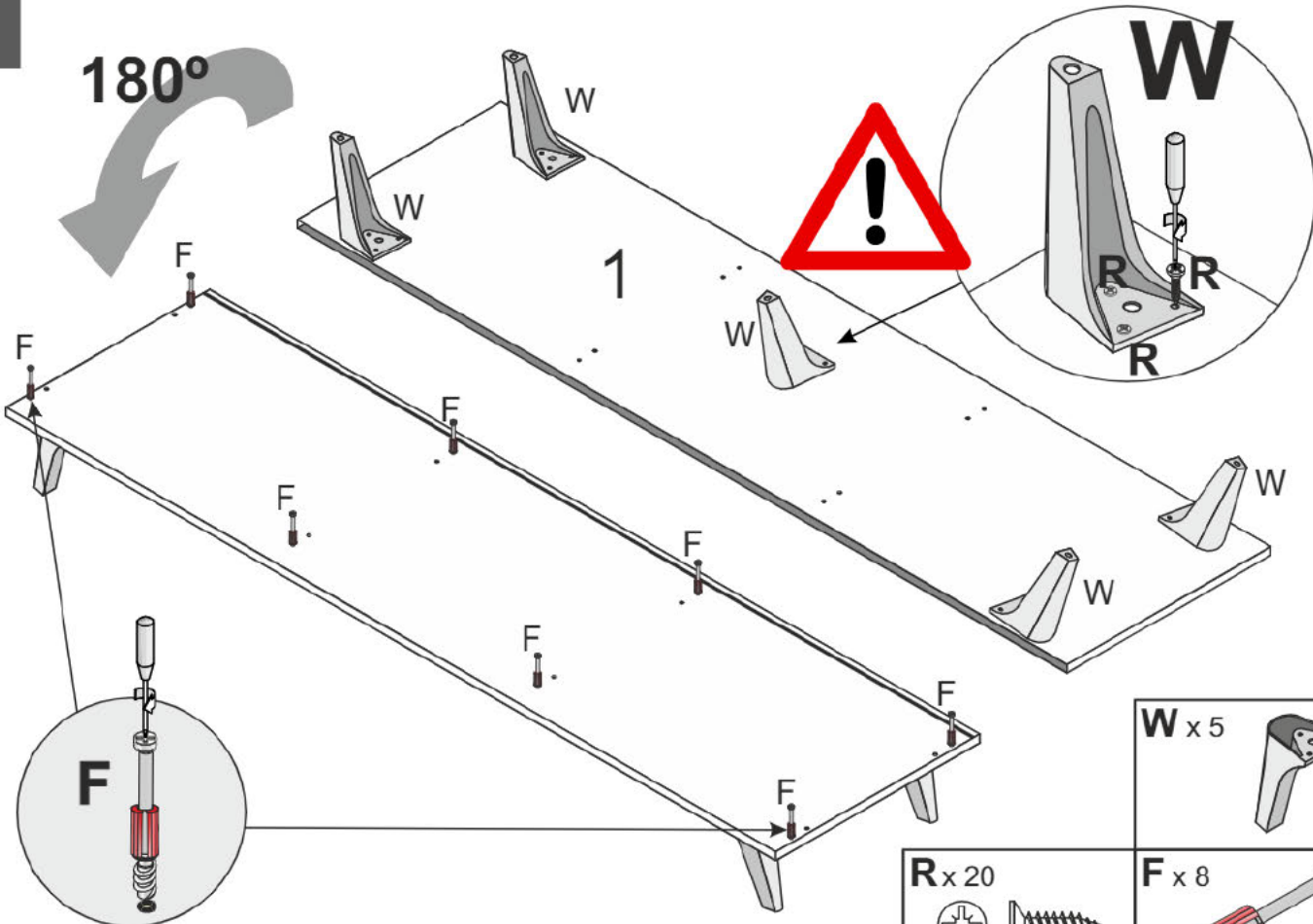

2

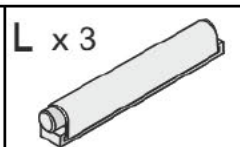
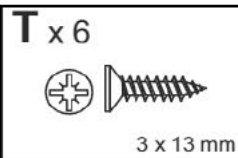
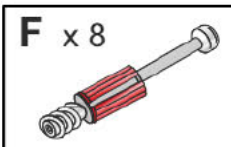
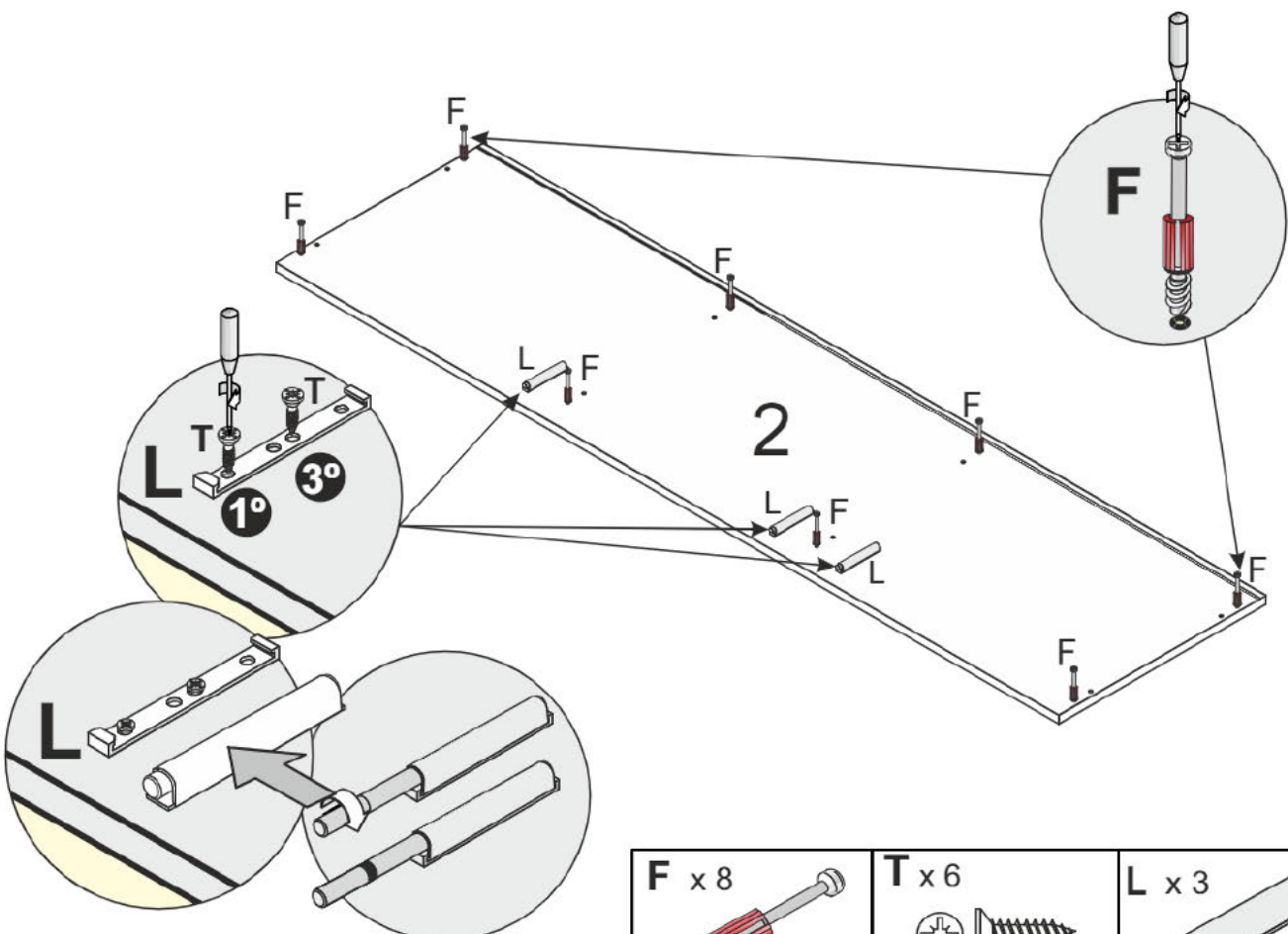

3

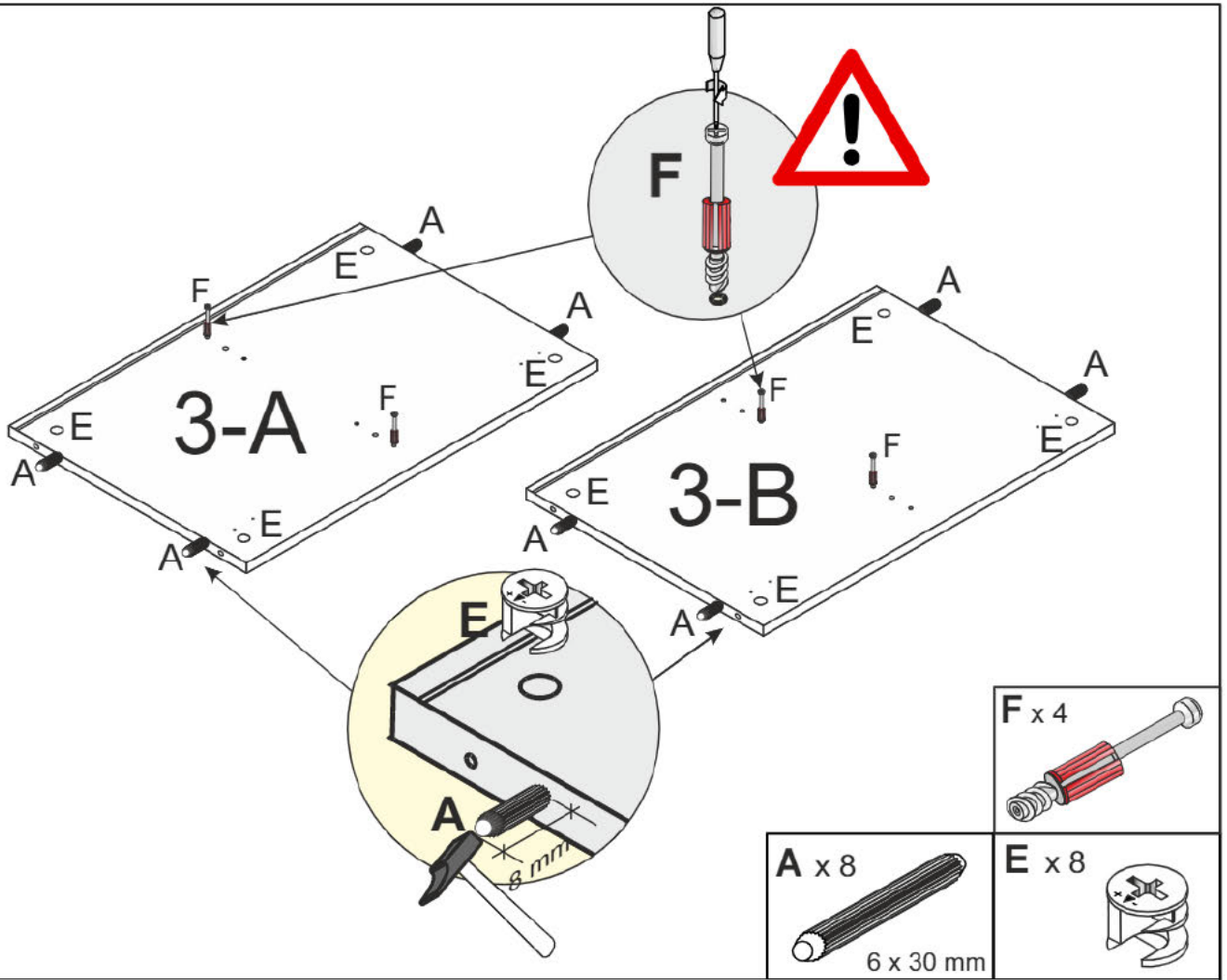

4

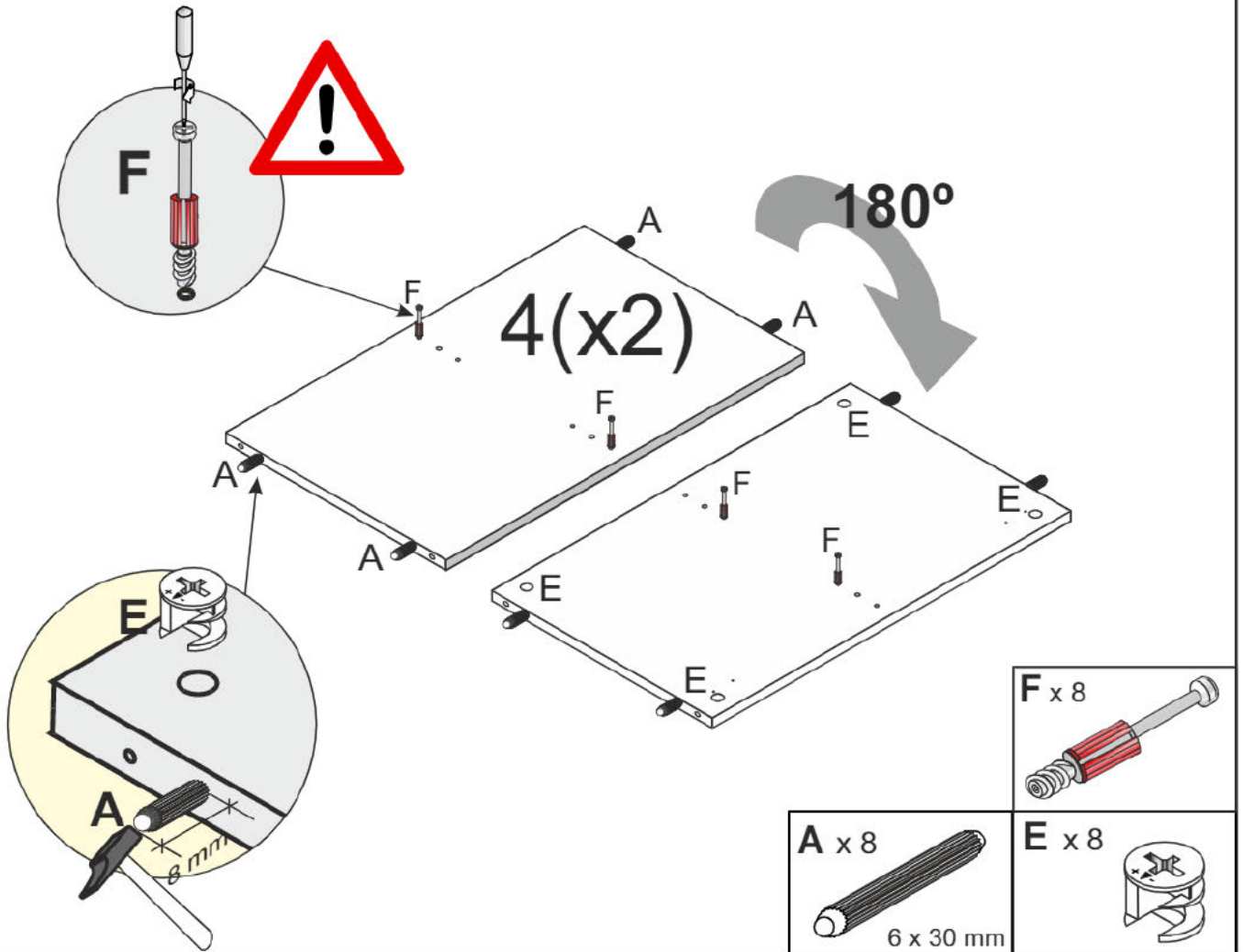

5

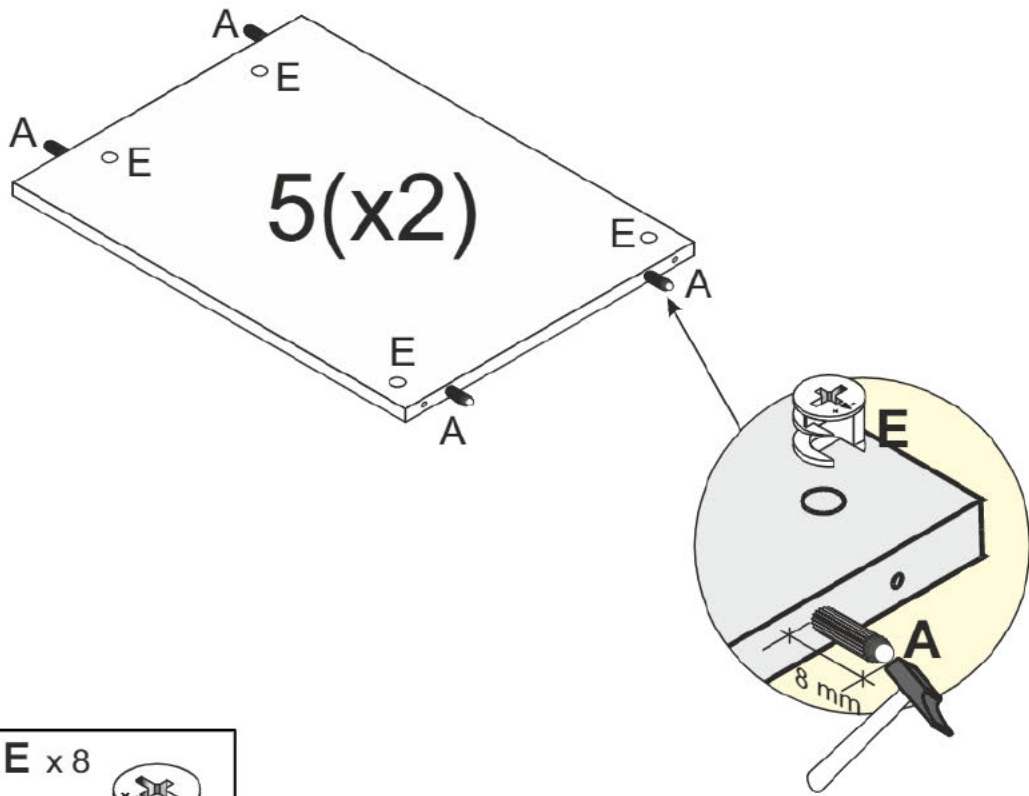

A x 8

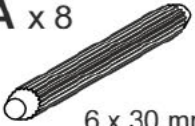

E x 8



6

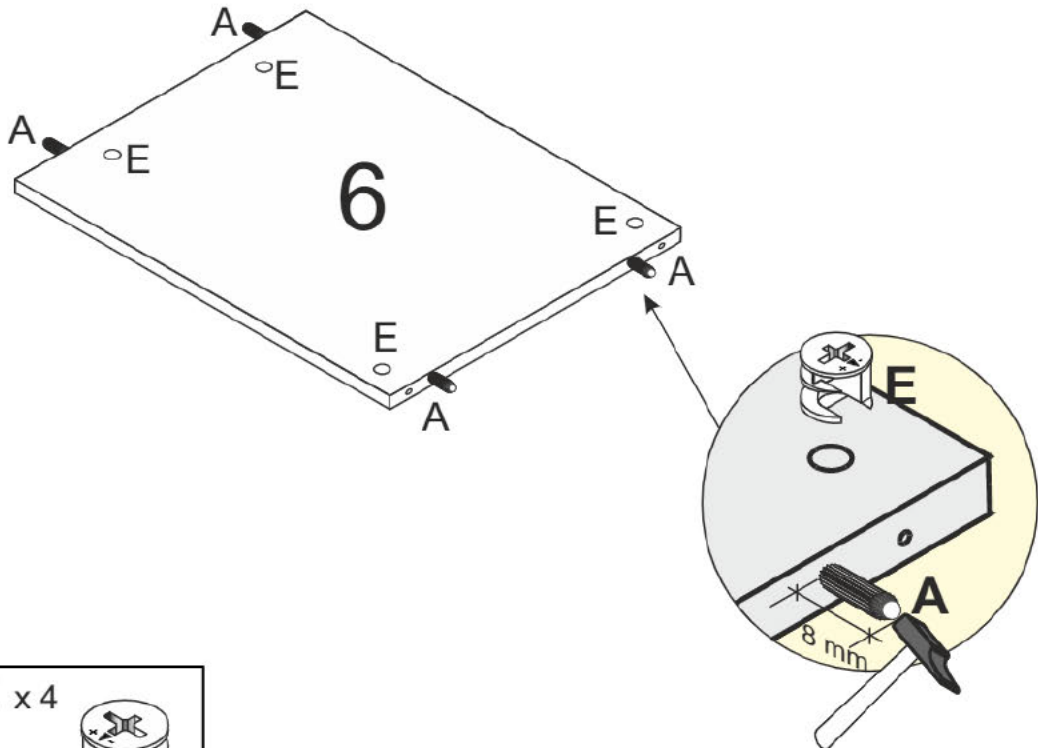

A x 4

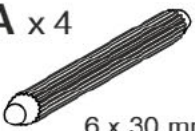

E x 4



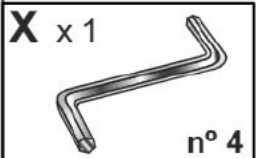
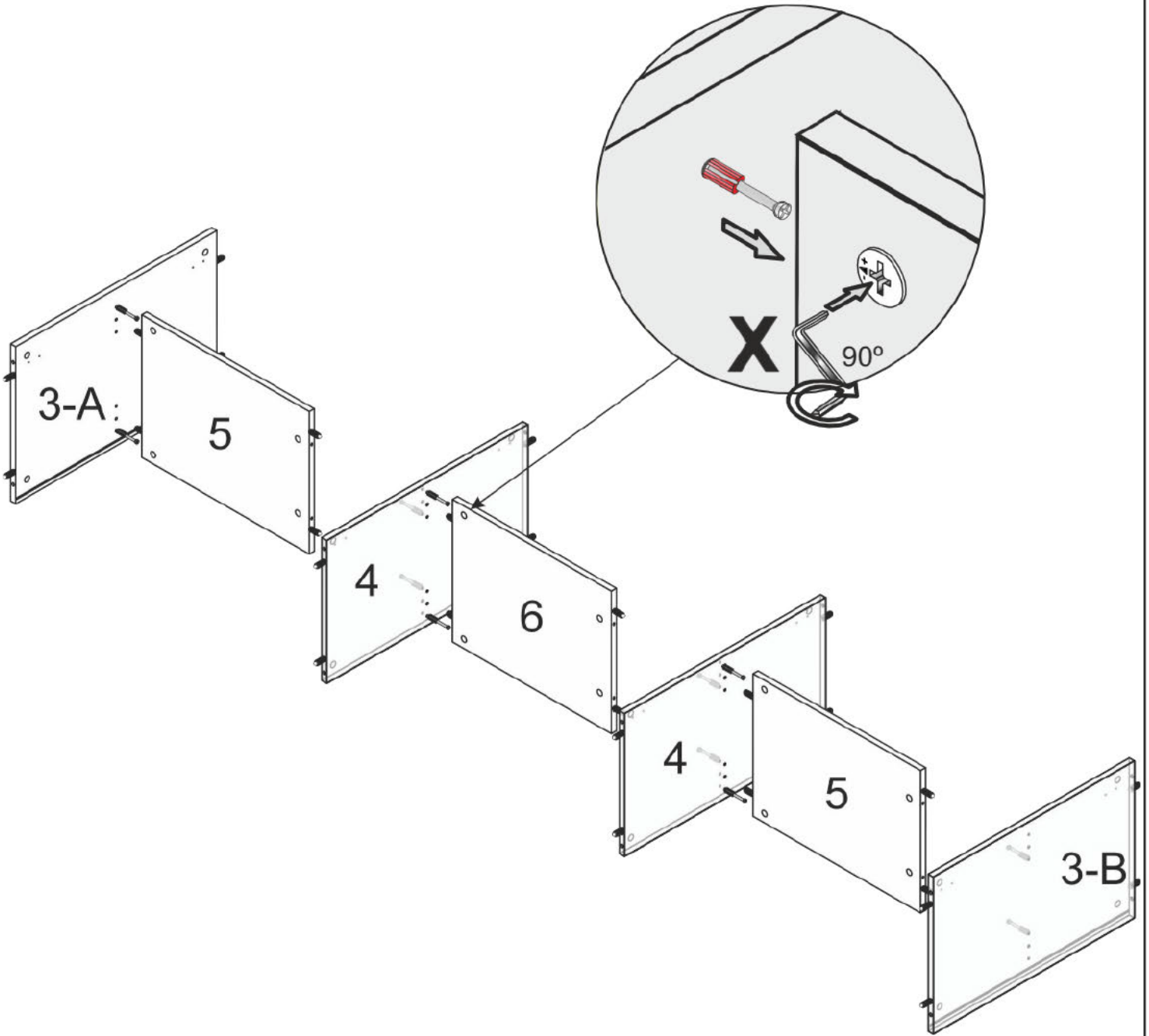

7

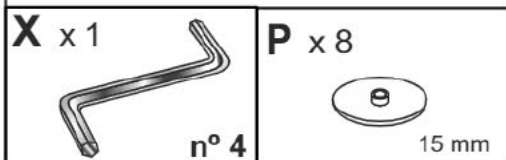
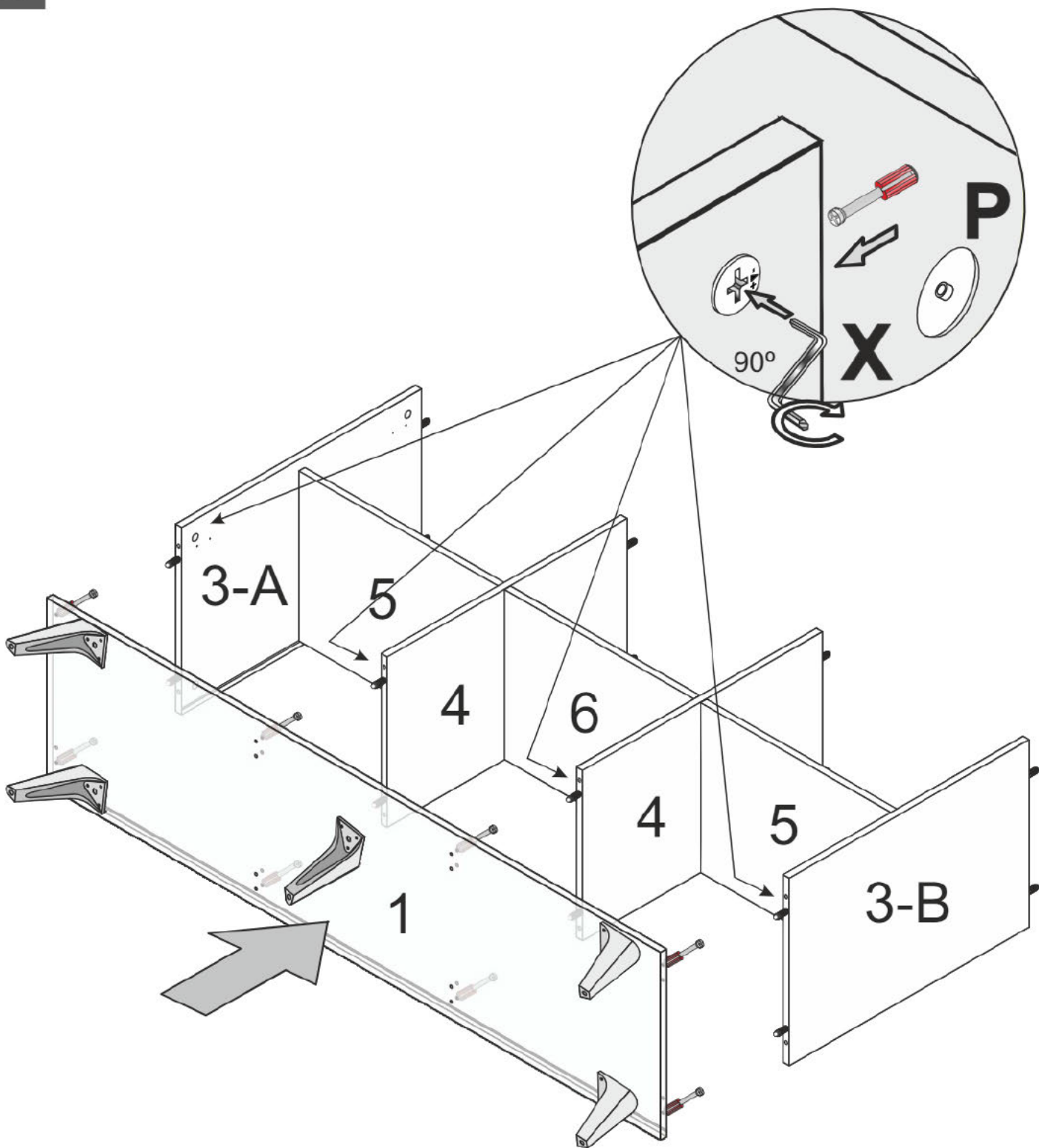

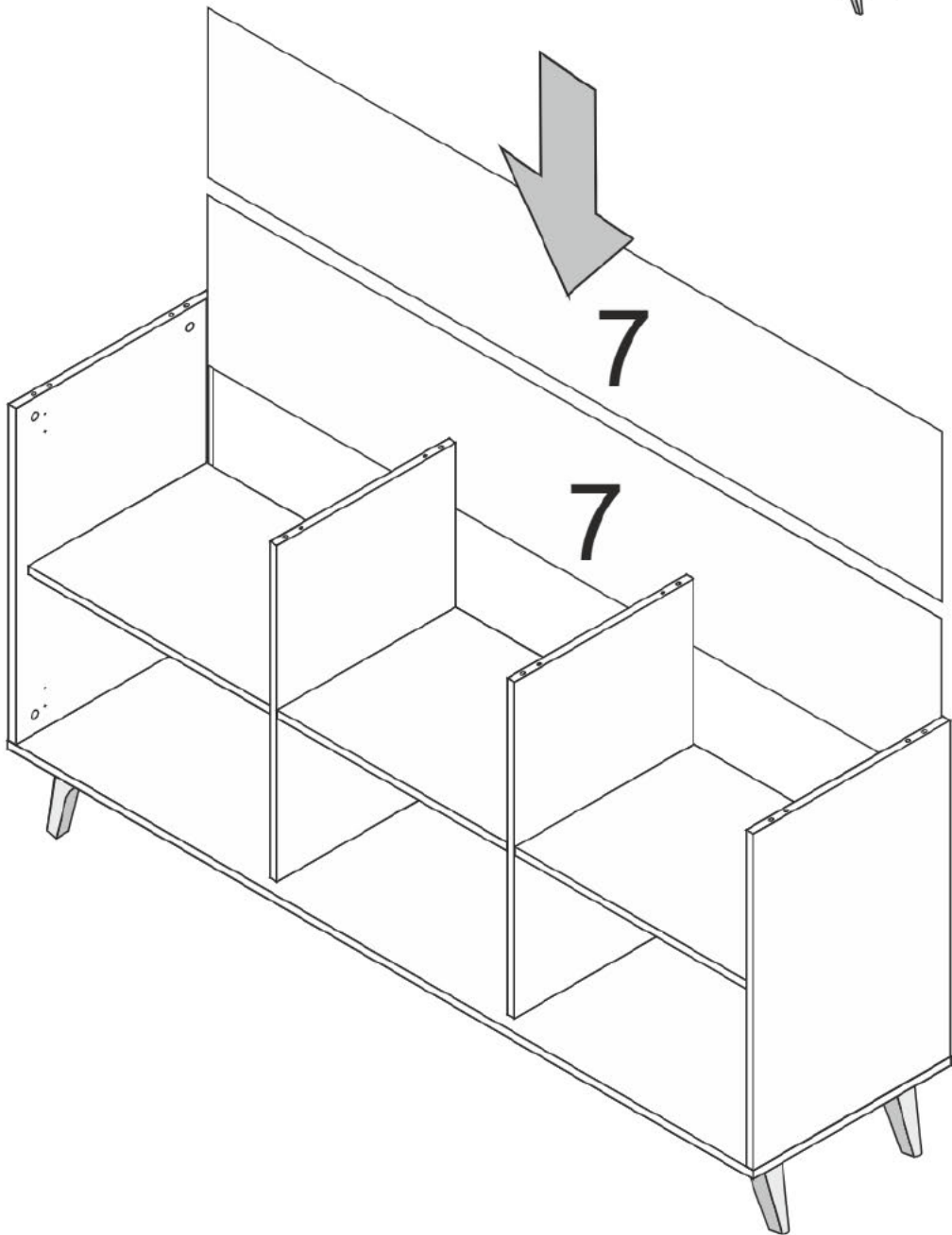
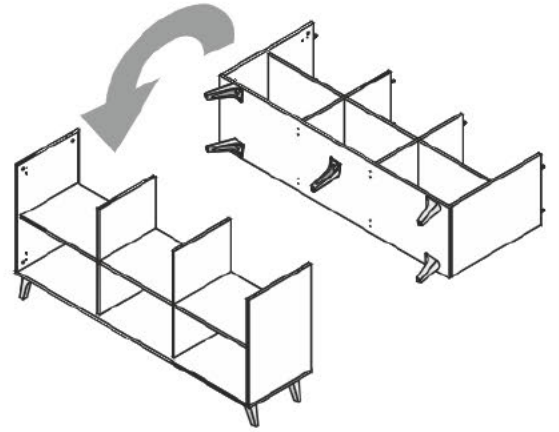

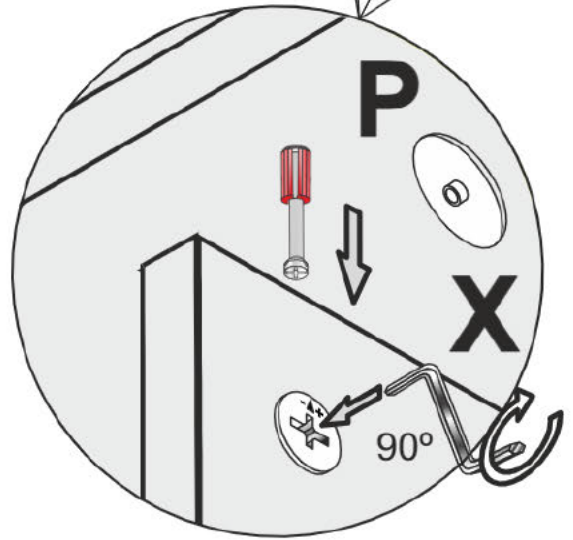
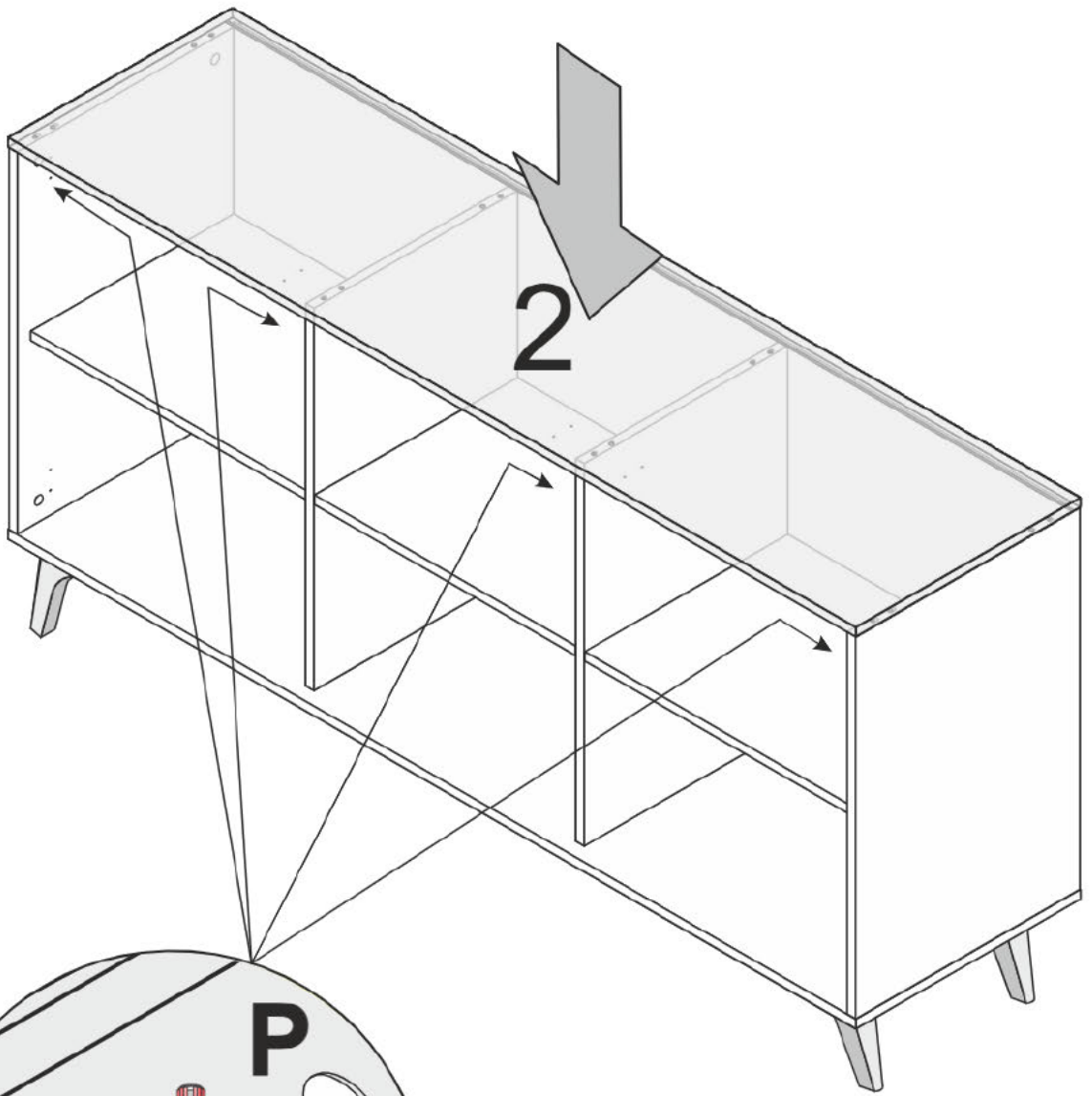

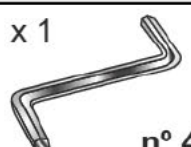

X x 1		P x 8	
	n° 4		15 mm

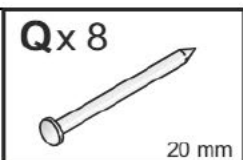
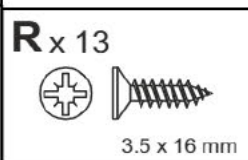
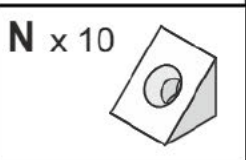
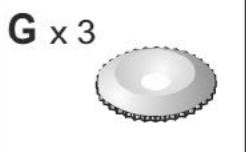
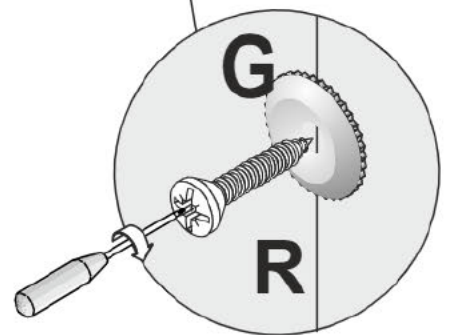
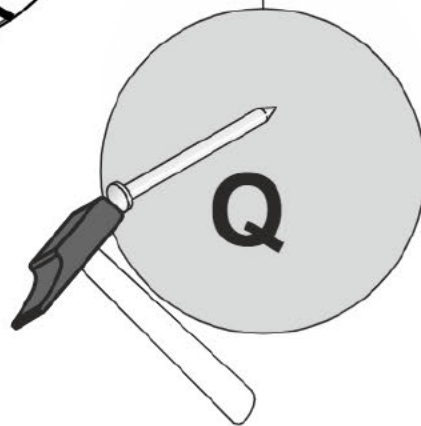
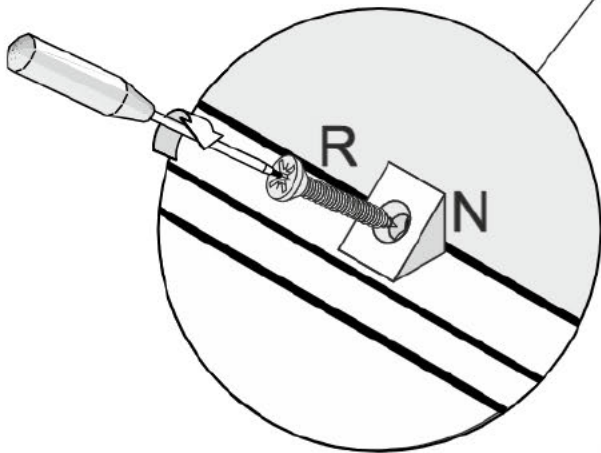
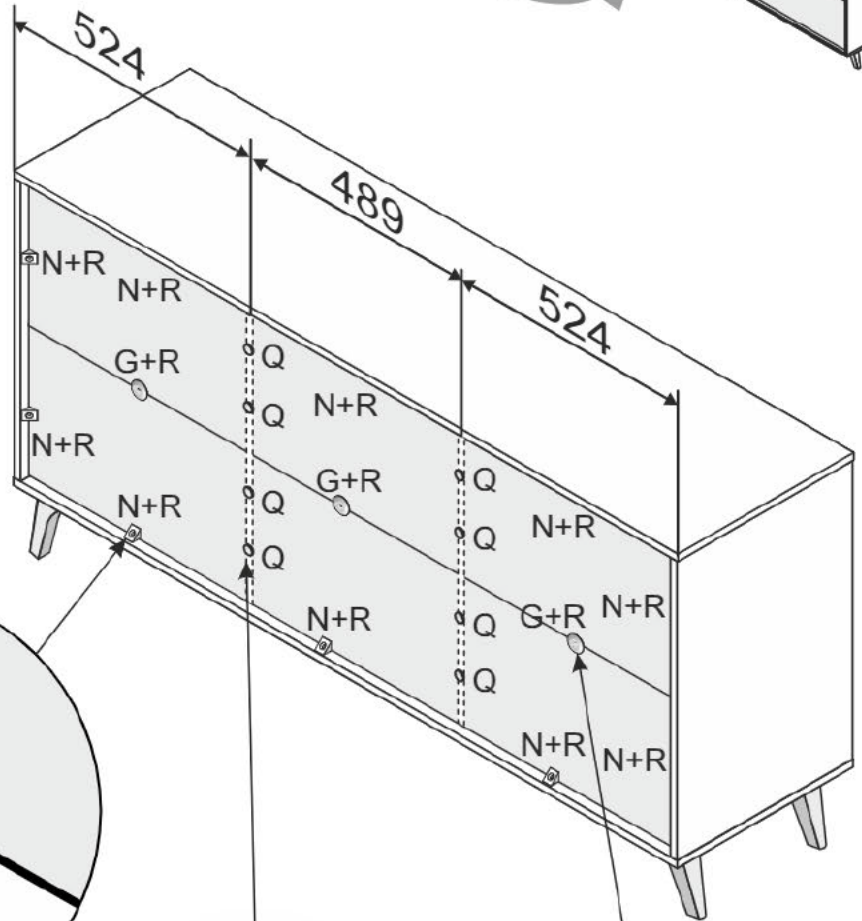
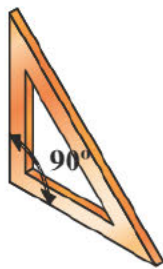
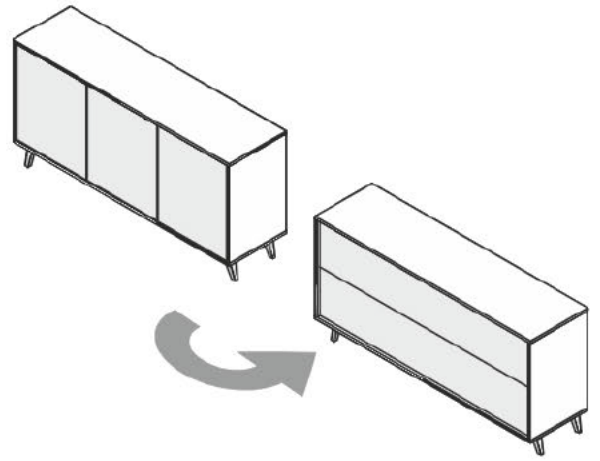

12

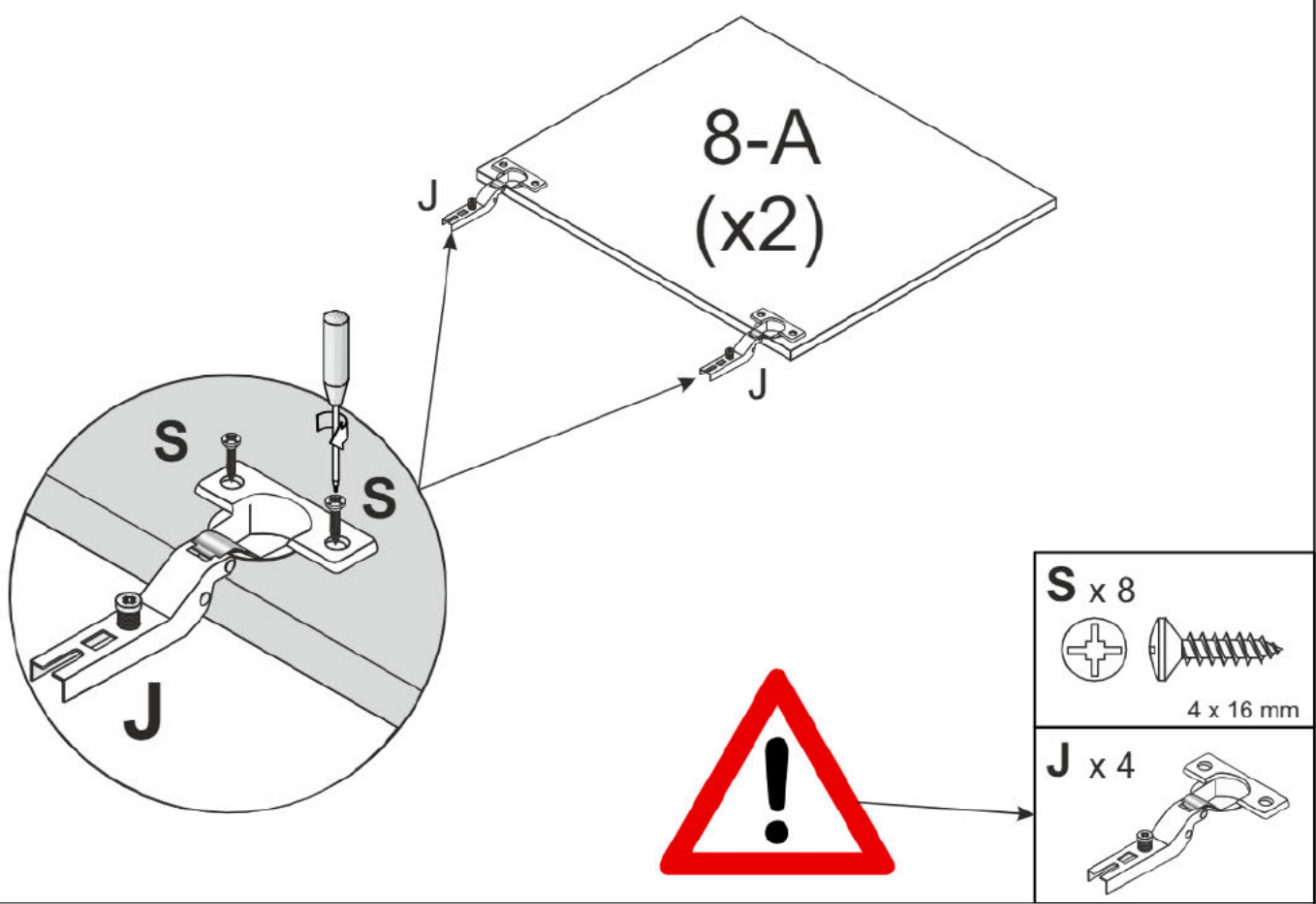

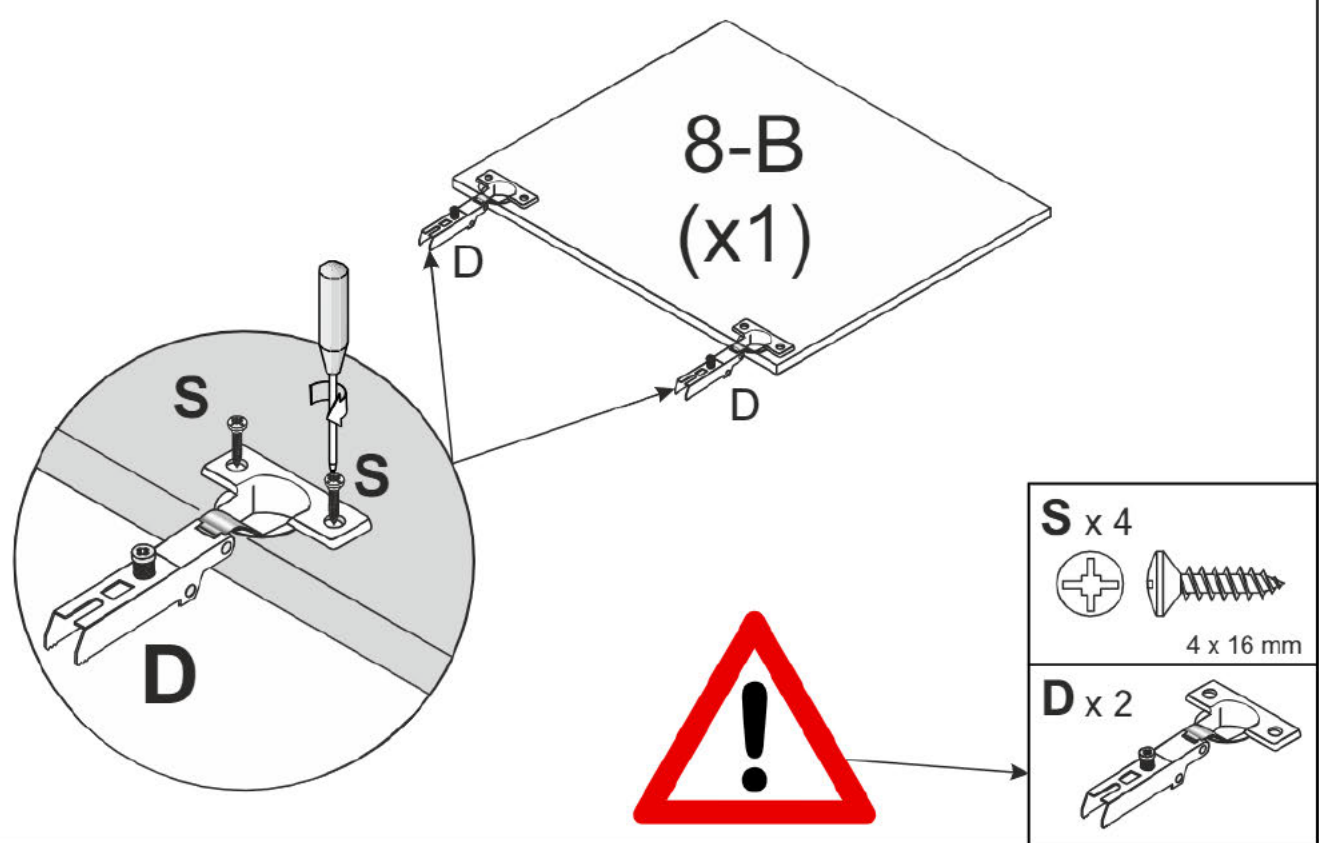

13

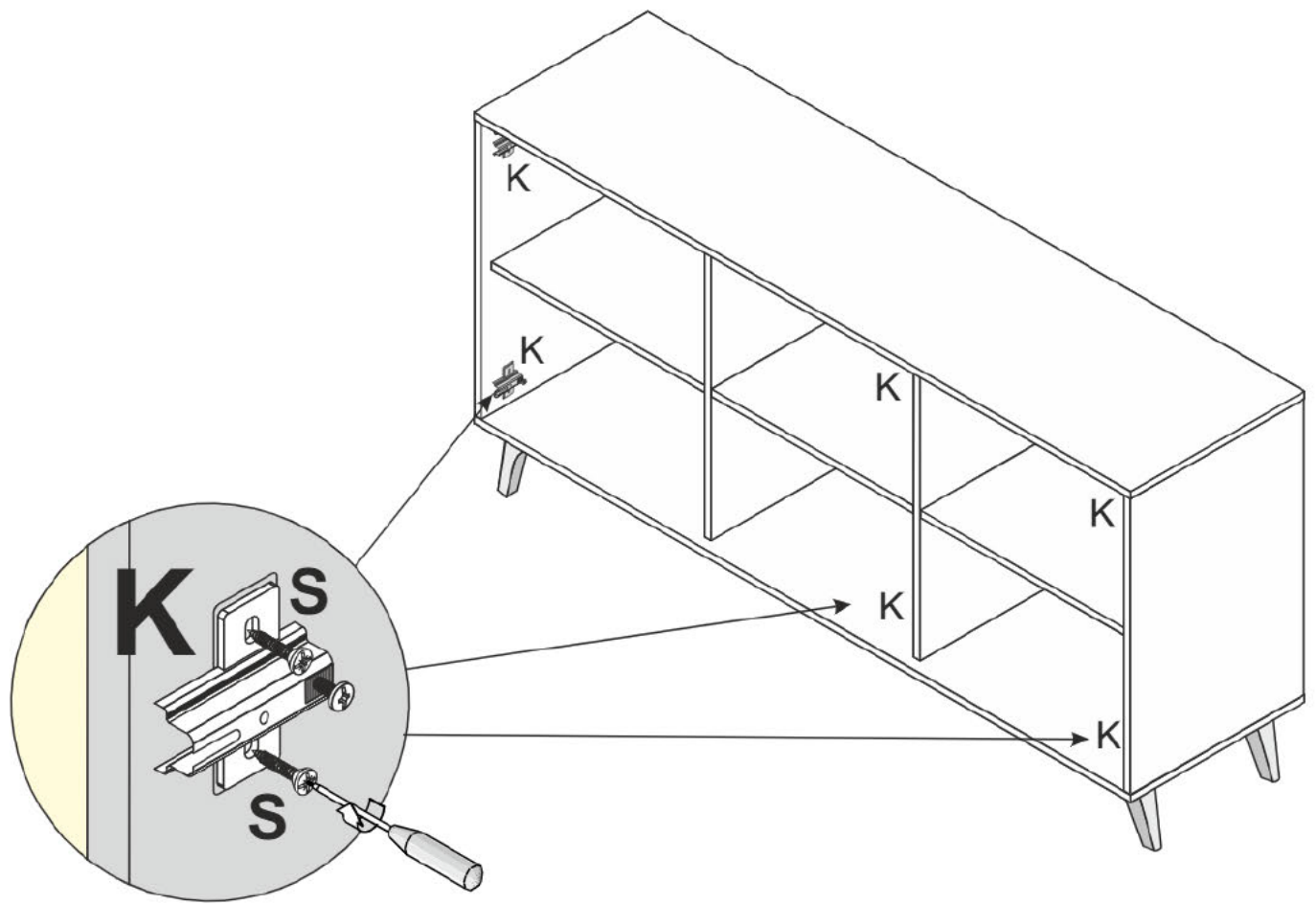

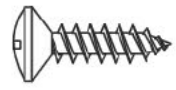

S x 12



4 x 16 mm

K x 6

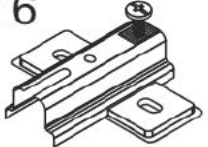

B x 4



13 mm

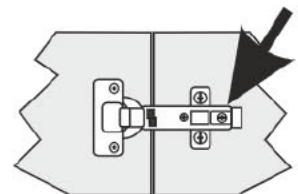
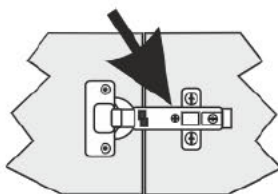
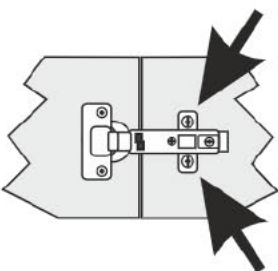
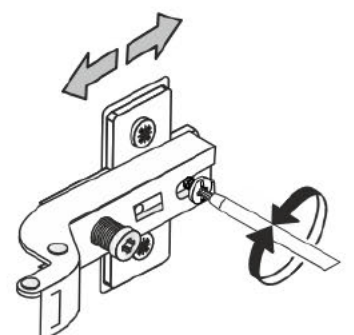
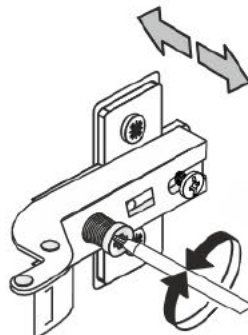
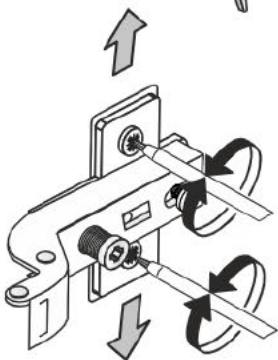
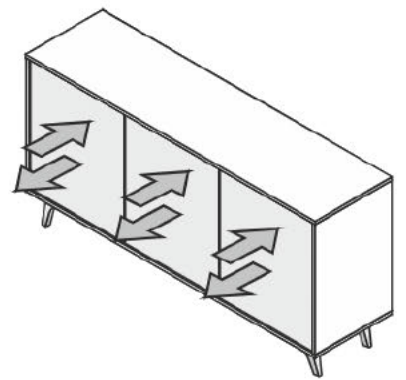
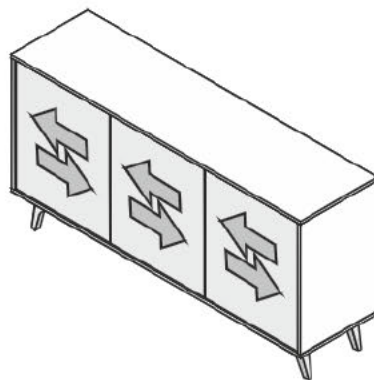
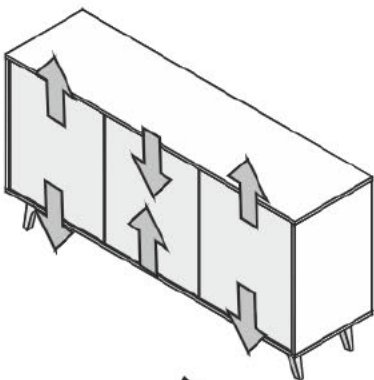
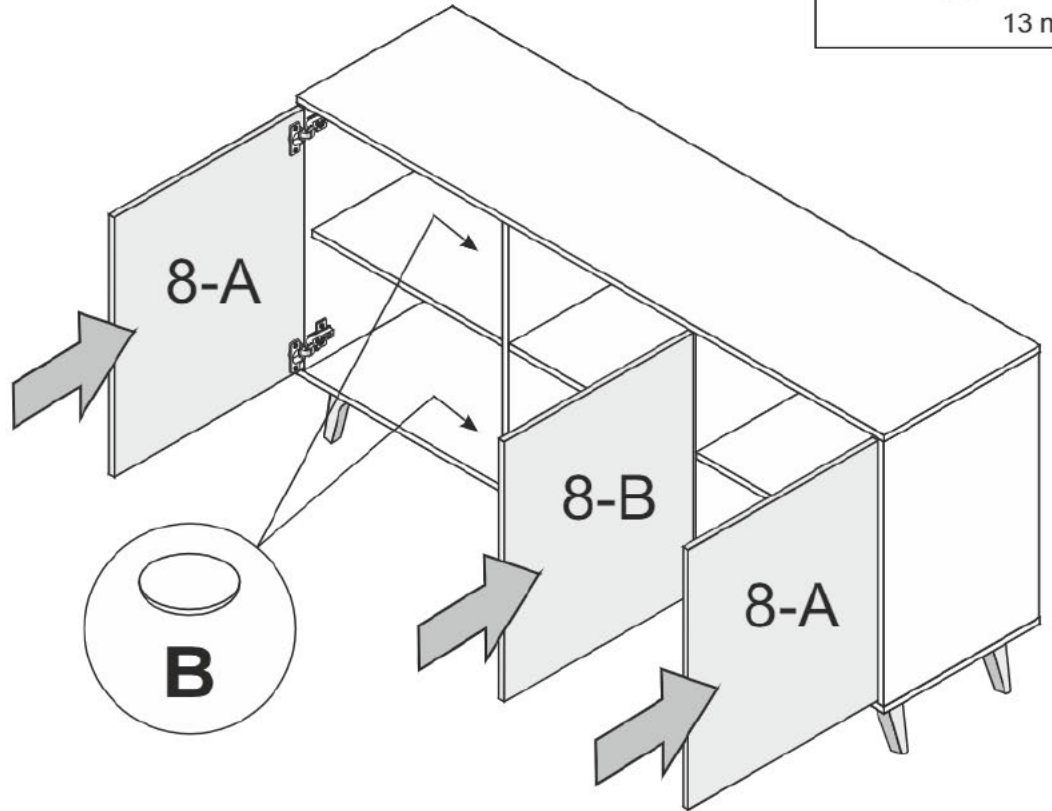

ES

MONTAJE

- Preparar las piezas que constituyen el mueble.
- Reagrupar y contar el herraje.
- Preparar las herramientas necesarias.
- Preparar la zona de montaje.
- Realizar el montaje sobre una moqueta para evitar rayar el mueble.
- No forzar nunca los ensamblajes.

USO

- No colocar cerca de fuentes de calor.
- Mueble apto para uso doméstico. Ubicación en el interior de la vivienda.
- Se recomienda, tras la instalación del mueble, airear la habitación donde se encuentre durante varias semanas.

MANTENIMIENTO Y LIMPIEZA

- Limpiar con un paño humedecido con una solución jabonosa.
- Secar con un paño limpio.
- No utilizar paños, trapos o productos de limpieza que puedan rayar la superficie del mueble

IT

INSTALLAZIONE

- Prerapare i pezzi che costituiscono il mobile.
- Raggruppare e contare la ferramenta.
- Preparare gli attrezzi necessari.
- Preparare una zona per il montaggio.
- Realizzare il montaggio sopra un tappeto per evitare che il mobile si graffi.
- Non forzare mai l'assemblaggio.

USO

- Non collocare vicino a fonti di calore.
- Mobile adatto ad un uso domestico. Adatto a uso interno.
- Dopo l'installazione del mobile, si consiglia di areggiare la stanza per varie settimane.

ISTRUZIONI PER LA PULIZIA

- Pulire con un panno umido e un detergente neutro.
- Asciugare con un panno pulito.
- Non utilizzare panni, trappi o prodotti di pulizia che possano graffiare la superficie del mobile.

EN

ASSEMBLE

- Prepare the different pieces of the furniture.
- Regroup and count the hardware.
- Prepare the necessary tools.
- Prepare the area to assemble to furniture.
- Assemble the furniture on a carpet to avoid any damages.
- Do not force the hardware.

USE

- Do not place the furniture near the heat sources.
- It's suitable for domestic use, keep it indoors.
- It is recommended, after the assembling to air the room for several weeks.

MAINTENANCE AND CLEANING

- Clean it with a damp cloth with mild cleaners.
- Dry it with a clean cloth.
- Do not use cloths or cleaning products that could damage the surface of the furniture.

DE

MONTAGEHINWEISE

- Sortieren und identifizieren Sie die Einzelteile.
- Überprüfen Sie die Anzahl der einzelnen Beschlagteile.
- Legen Sie das notwendige Werkzeug bereit.
- Machen Sie einen Montagebereich frei.
- Montieren Sie das Möbelstück auf einem ebenen, weichen und sauberen Untergrund.
- Überziehen Sie die Beschlagteile nicht.

GEBRAUCHSHINWEISE

- Platzieren Sie das Möbelstück niemals neben Wärmequellen.
- Das Möbelstück ist ausschließlich für den Gebrauch im Haus geeignet.
- Es wird empfohlen, nach dem Aufbau des Möbelstücks, den Raum in dem es sich befindet, mehrere Wochen lang zu lüften.

REINIGUNG UND PFLEGE

- Mit einem feuchten Tuch mit milder Seifenlösung abwischen.
- Trocken nachwischen.
- Für die Reinigung verwenden Sie bitte ein weiches Tuch und keinesfalls scharfe oder ätzende

FR

MONTAGE

- Identifier les différents panneaux.
- Regrouper et compter la quincaillerie.
- Munissez-vous de l'outillage nécessaire.
- Aménagez-vous une zone de montage. La moquette ou une couverture protégera des rayures.
- Ne jamais forcer le montage.

USAGE

- Ne pas placer près des sources de chaleur.
- Meuble apte pour l'usage domestique, on peut le placer à l'intérieur de la maison.
- Il est recommandé, après l'installation du meuble dans son logement, d'aérer fréquemment la pièce concernée pendant quelques semaines.

ENTRETIEN ET NETTOYAGE

- Nettoyer avec un chiffon humide et une solution savonneuse.
- Essuyer avec un chiffon sec et propre.
- N'utiliser pas de chiffons ou des produits de nettoyage qui puissent rayer la superficie du meuble.

GR

ΣΥΝΑΡΜΟΛΟΓΗΣΗΣ

- Προετοιμάστε τα μέρη του επίπλου.
- Ομαδοποιήστε και μετρήστε τα μικρά μέρη (βίδες, μεντεσέδες...).
- Προετοιμάστε τα εργαλεία που θα χρειαστείτε.
- Προετοιμάστε το χώρο συναρμολόγησης.
- Μια μοκέτα θα προφύλασσε από γρατζουνιές.
- Μη ασκείτε πίεση στην εφαρμογή.

ΧΡΗΣΗΣ

- Μη το τοποθετείτε κοντά σε πηγή θερμότητας.
- Το έπιπλο έχει κατασκευαστεί για οικιακή χρήση, τοποθετείστε το στο εσωτερικό της οικίας.
- Συνιστάται, μετά την εγκατάσταση του επίπλου, ο χώρος να αερίζεται για αρκετές εβδομάδες, ές ουσίς.

ΣΥΝΤΗΡΗΣΗ ΚΑΙ ΚΑΘΑΡΙΣΜΟΣ

- Καθαρίστε το με ένα πανί μουσκεμένο σε ένα ελαφρύ απορρυπαντικό.
- Στεγνώστε το με ένα καθαρό πανί.
- Μη χρησιμοποιείτε πανιά και καθαριστικά που μπορούν να καταστρέψουν την επιφάνεια.

PT

MONTAGEM

- Prepare as peças que compõem o móvel.
- Reagrupe e contar as ferragens.
- Prepare as ferramentas necessárias.
- Prepare a área para a montagem.
- Efetuar a montagem sobre uma alcatifa para evitar arranhar o móvel.
- Não forçar nunca a ensambladura.

USO

- Não colocar perto de fontes de calor.
- Móvel apto para o uso doméstico. Colocação no interior da vivenda.
- Após a instalação dos móveis, é recomendável ventilar por várias semanas a sala onde está localizado.

MANUTENÇÃO E LIMPEZA

- Limpe bem com um pano humedecido numa solução detergente suave.
- Seque bem com um pano limpo.
- Não utilizar panos, trapos ou produtos de limpeza que possam riscar a superfície do móvel.

