

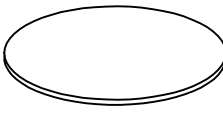

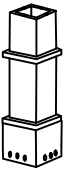

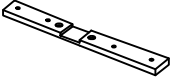

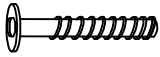
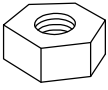

# PART LIST

<div data-bbox="193 226 240 264" data-label="Text">#A2</div> 	<div data-bbox="435 226 483 264" data-label="Text">#B2</div> 	<div data-bbox="678 226 726 264" data-label="Text">#C2</div> 	<div data-bbox="920 226 968 264" data-label="Text">#D2</div> 
<p>Table Top 1 PC</p>	<p>Pedestal 1 PC</p>	<p>Top Rail 2 PCS</p>	<p>Leg 4 PCS</p>



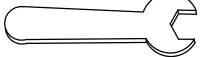

# HARDWARE LIST

<div data-bbox="183 779 231 817" data-label="Text">#1</div>  <p>M6 x 35mm</p>	<div data-bbox="426 779 474 817" data-label="Text">#2</div>  <p>5/16"</p>	<div data-bbox="668 779 716 817" data-label="Text">#3</div>  <p>5/16"</p>	<div data-bbox="911 779 959 817" data-label="Text">#4</div>  <p>5/16"x22"</p>	<div data-bbox="1153 779 1201 817" data-label="Text">#5</div>  <p>1/4"</p>
<p>Bolt 12 PCS (Extra 1)</p>	<p>Hex Nut 8 PCS (Extra 1)</p>	<p>Spring Washer 8 PCS (Extra 1)</p>	<p>Flat Washer 8 PCS (Extra 1)</p>	<p>Small Spring Washer 12 PCS (Extra 1)</p>

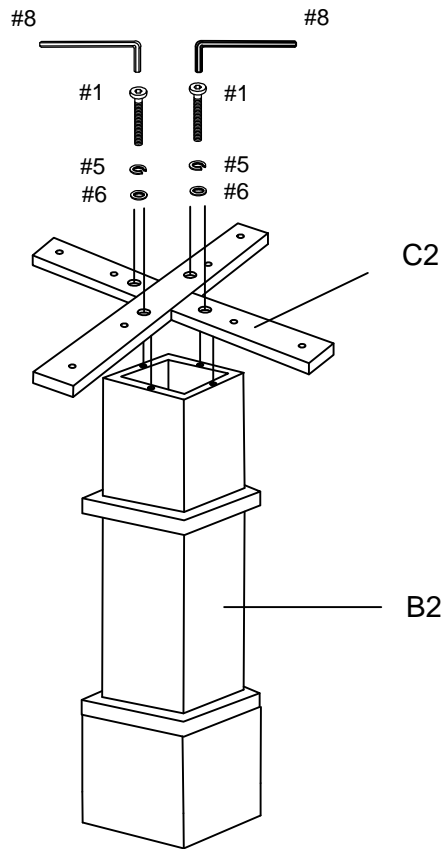
<div data-bbox="183 1173 231 1211" data-label="Text">#6</div>  <p>M6 x 13mm</p>	<div data-bbox="426 1173 474 1211" data-label="Text">#7</div>  <p>12.8mm</p>	<div data-bbox="668 1173 716 1211" data-label="Text">#8</div>  <p>M4</p>
<p>Small Flat Washer 12 PCS (Extra 1)</p>	<p>Wrench 1 PC</p>	<p>Allen Wrench 1 PC</p>





Step 1 . Attach top rails (parts C2) to pedestal (part B2) using small flat washers (part #6), small spring washers (part #5), bolts (part #1) and allen wrench (part #8).

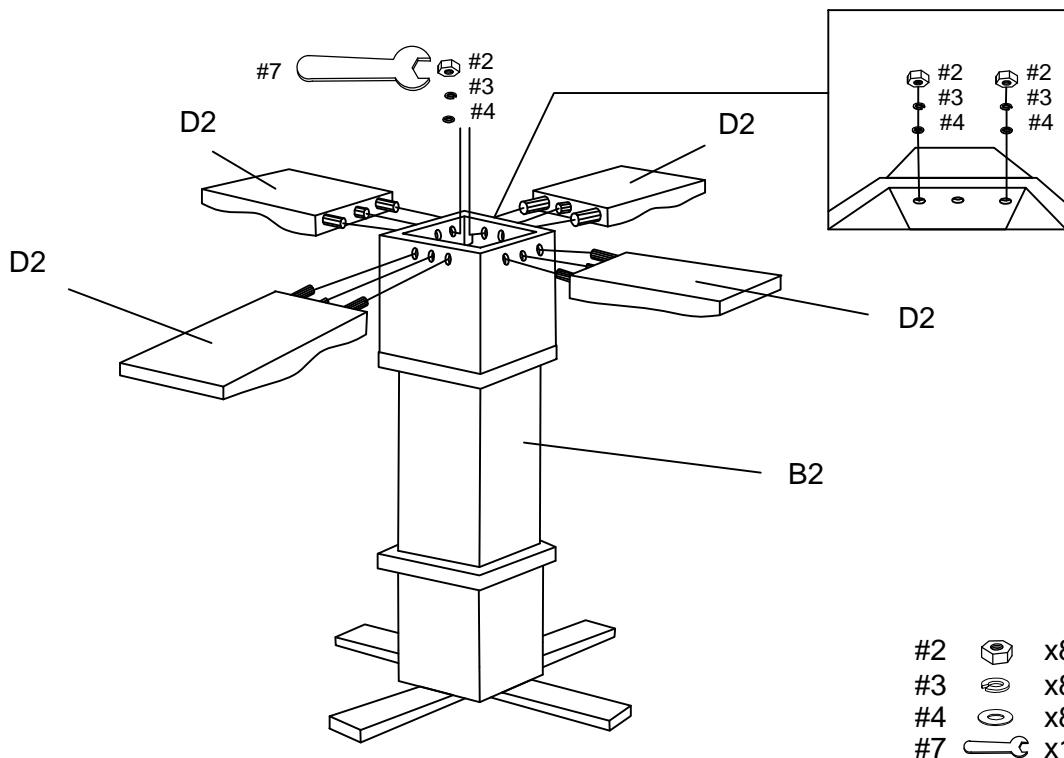

- #1  x4
- #5  x4
- #6  x4
- #8  x1

Step 2 . Attach legs (part D2) to pedestal (part B2) using flat washers (part #4), spring washers (part #3), hex nuts (part #2) and wrench (part #7).



- #2  x8
- #3  x8
- #4  x8
- #7  x1

Step 3 . Lay table top (part A2) upside down on a soft flat surface, such as carpet. Attach top rails (part C2) to table top (part A2) using small flat washers (part #6), small spring washers (part #5), bolts (part #1) and allen wrench (part #8).

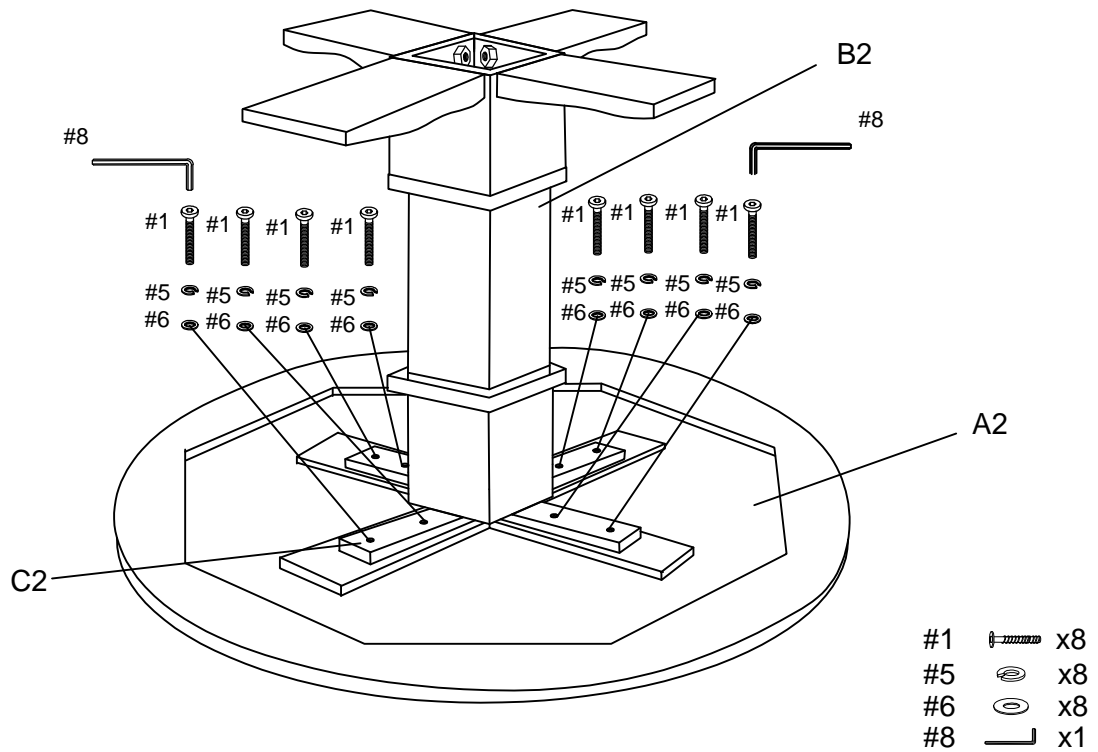

Step 4 . Carefully turn assembled unit upright.

