

PRODUCT : ASTORIA OFFICE DESK
CODE : ATA 01
DIMENSIONS : 220x90x75
TOTAL PACKAGES : 2

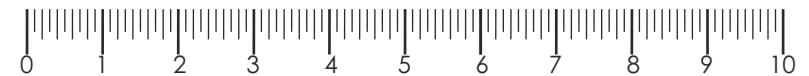
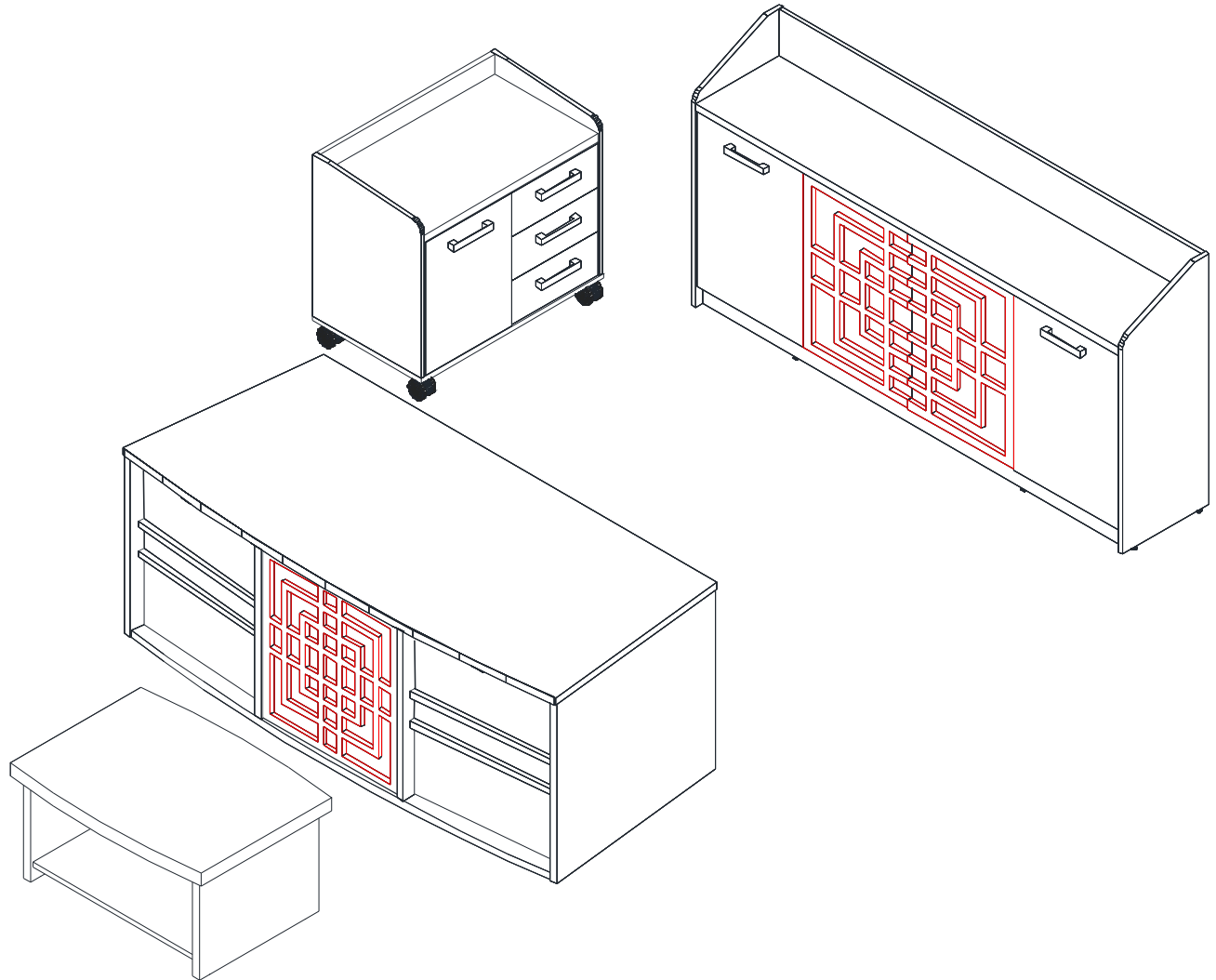

PRODUCT : ASTORIA CABINET
CODE : ATA 04
DIMENSIONS : 199x41x100
TOTAL PACKAGES : 2

PRODUCT : ASTORIA ETAGERE
CODE : ATA 03
DIMENSIONS : 84x50x75
TOTAL PACKAGES : 2

PRODUCT : ASTORIA COFFEE TABLE
CODE : ARM 04
DIMENSIONS : 80x55x42
TOTAL PACKAGES : 1

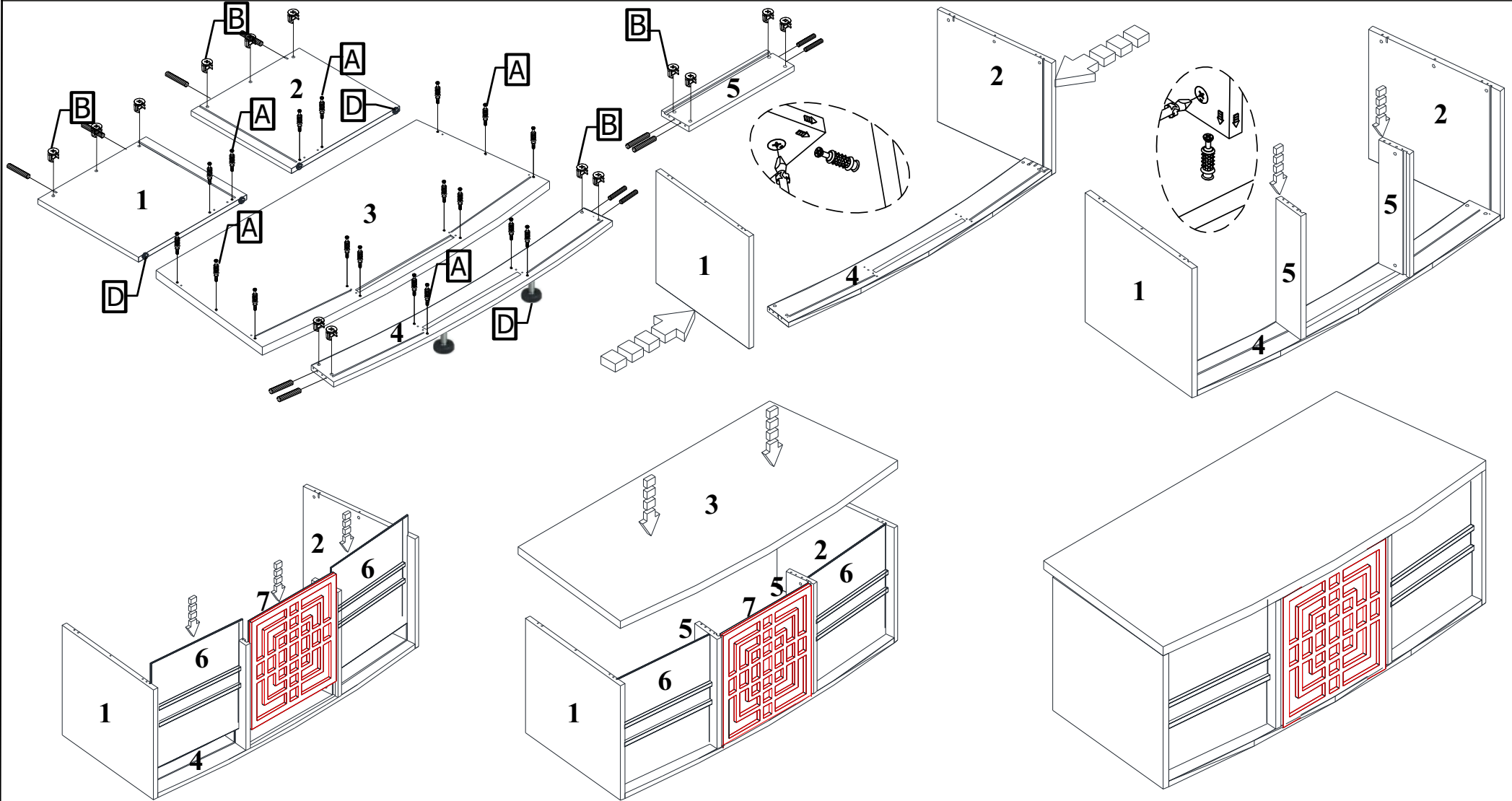

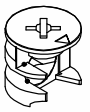



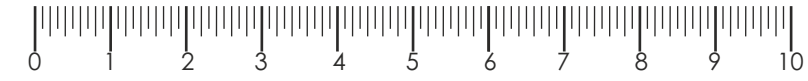

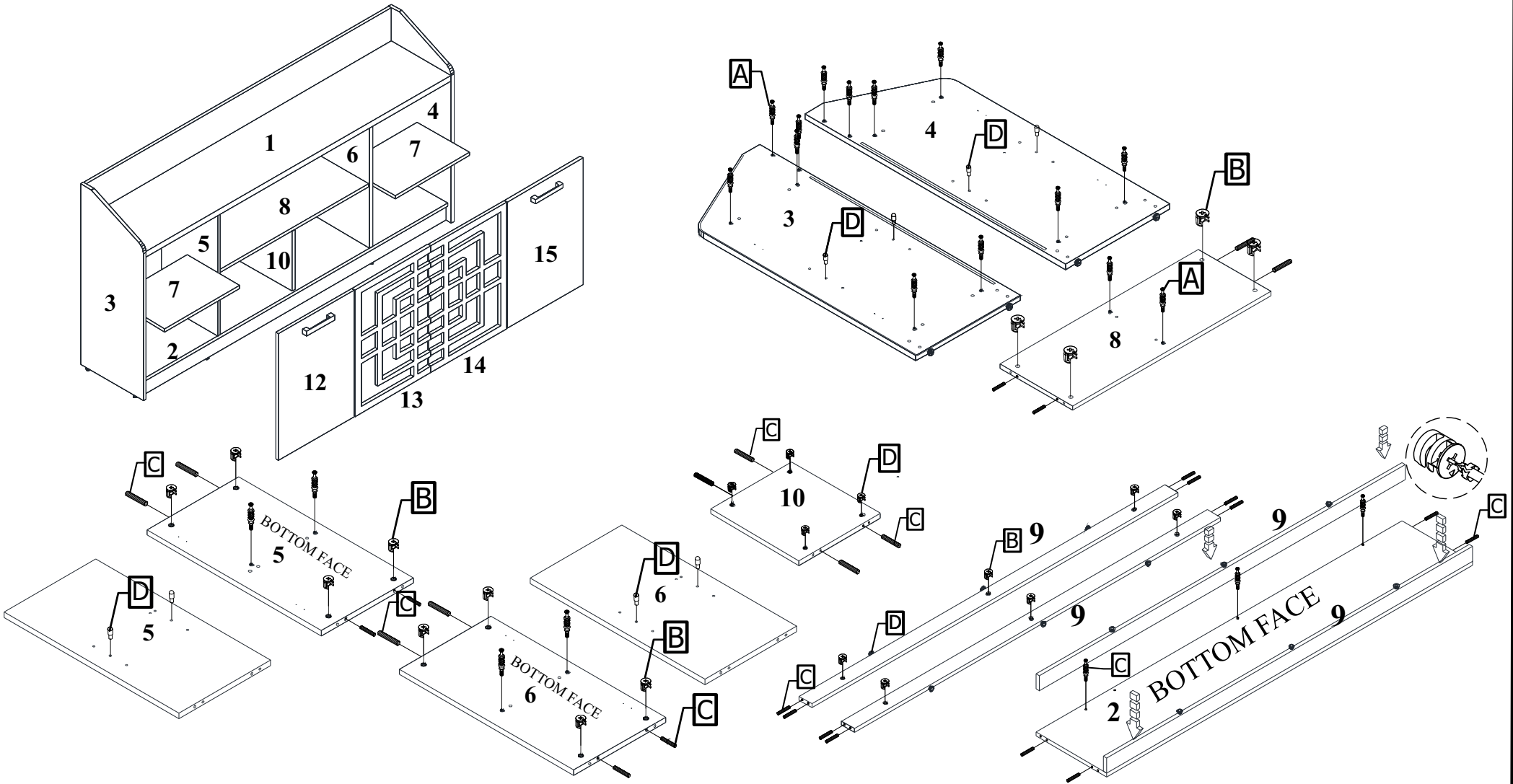









Part Code	Quantity	A 18	B 18	C 10	D 6													
Part Name																		
Part Number		102-001	102-002	102-003	102-003													





Part Code	Quantity	A	B	C	D	E	F	G	H	I	J	K	L	M	N
Part Name															
Part Number		102-001	102-002	102-003	102-004	102-005	102-006	102-007	102-008	102-009	102-010	102-011	102-012	102-013	102-014



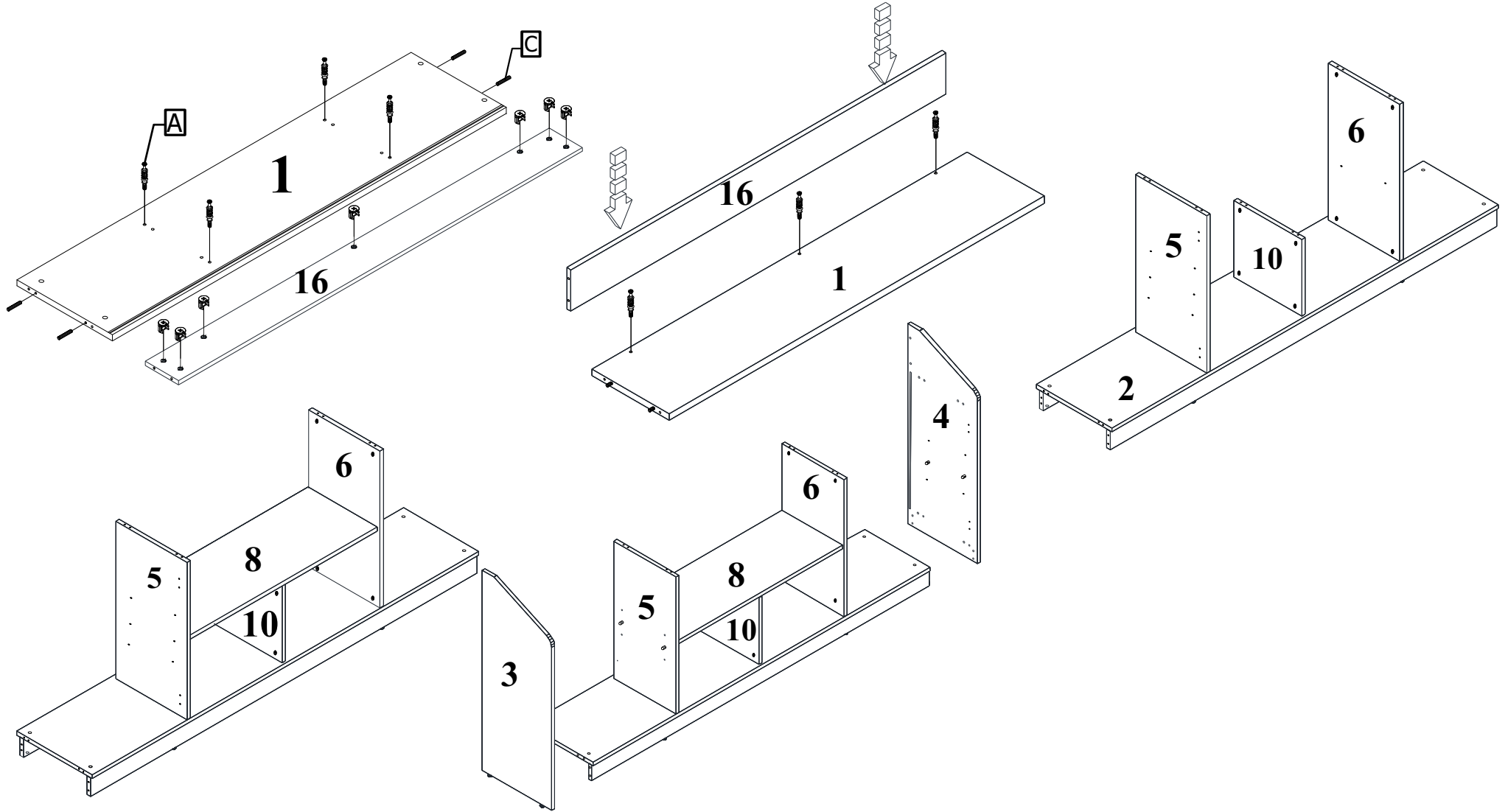

Part Code	Quantity	A	B	C	D	E	F	G	H	I	J	K	L	M	N
Part Name															
Part Number		102-001	102-002	102-003	102-004	102-005	102-006	102-007	102-008	102-009	102-010	102-011	102-012	102-013	102-014



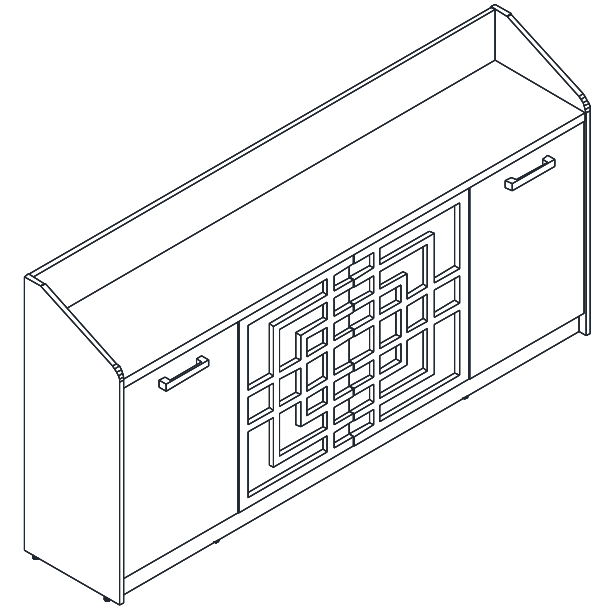
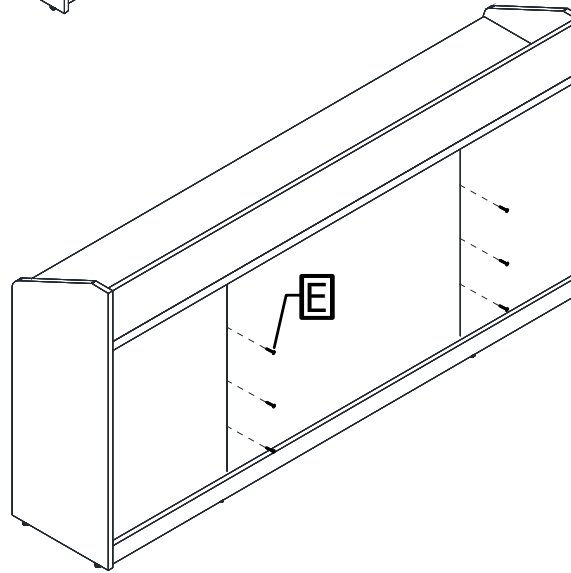
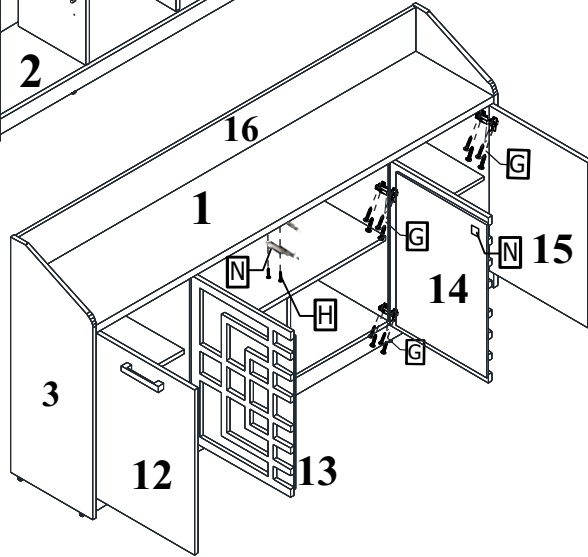
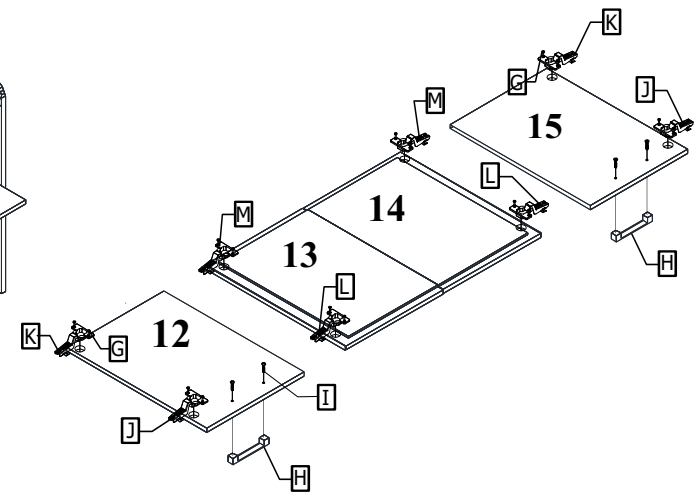
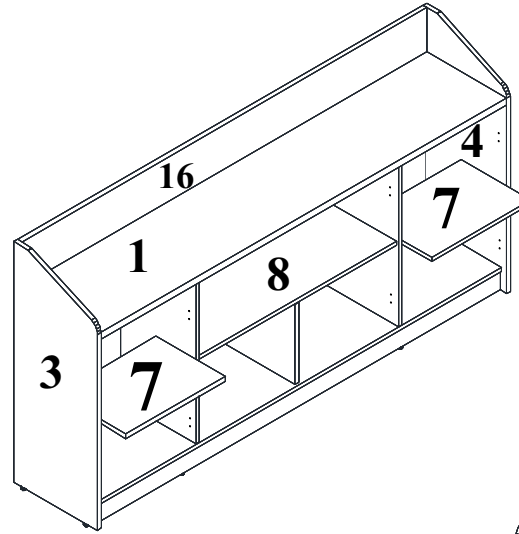
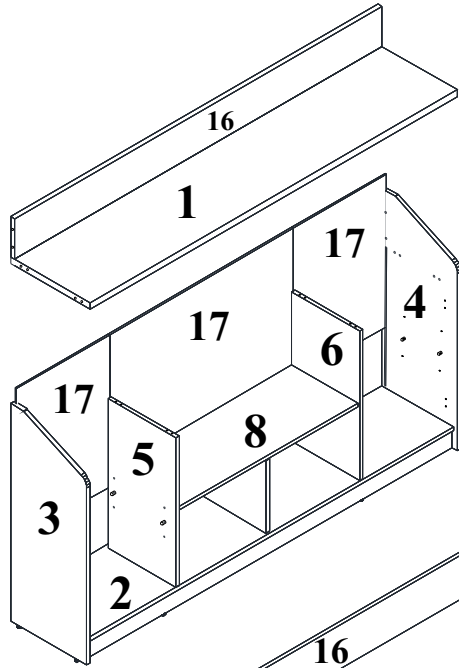

Part Code Quantity

Part Name

Part Number

A 36



MINIFIX STEEL SHAFT
102-001

B 36

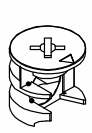

MINIFIX SCREW
102-002

C 36



Ø8 x 30 PLS DOWEL
102-003

D 8



SHELF PIN (5 MM) (Y-45)
102-004

E 6



4*35 SCREWS
102-005

F 10



PINGO M6 (Y-166)
102-006

G 36



3,5*18 SCREWS
102-007

H 5



CHROME HANDLE 160 MM (Y-661)
102-008

I 10



HANDLE SCREW M4*22 YHB (Y-119)
102-009

J 2

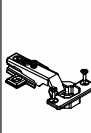

SOFT CLOSING FULL OVERLAY HINGE
102-010

K 2

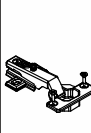

FULL OVERLAY HINGE
102-011

L 2

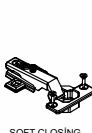

SOFT CLOSING HALF OVERLAY HINGE
102-012

M 2

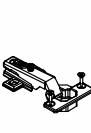

HALF OVERLAY HINGE
102-013

N 2



PUSH-OPEN PUSHER
102-014



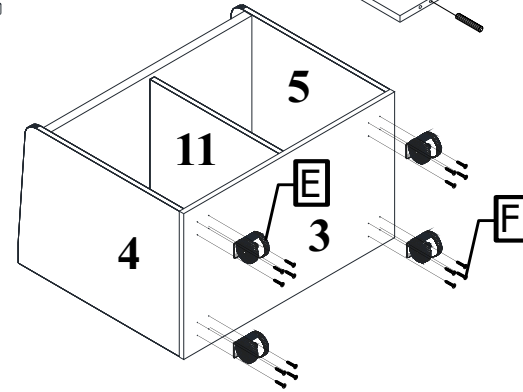
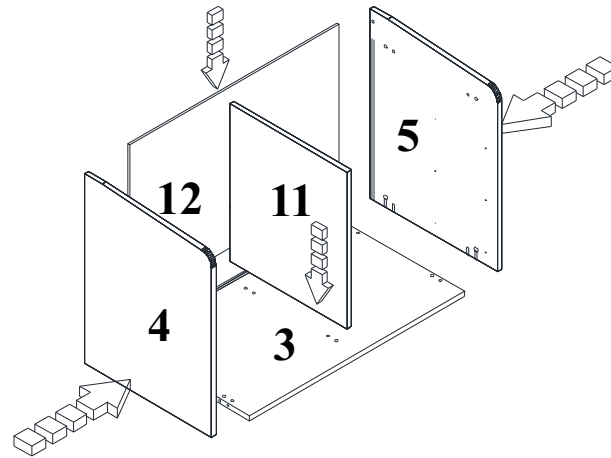
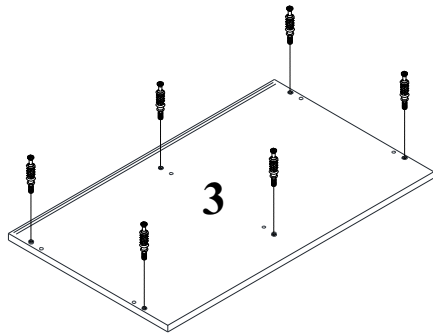
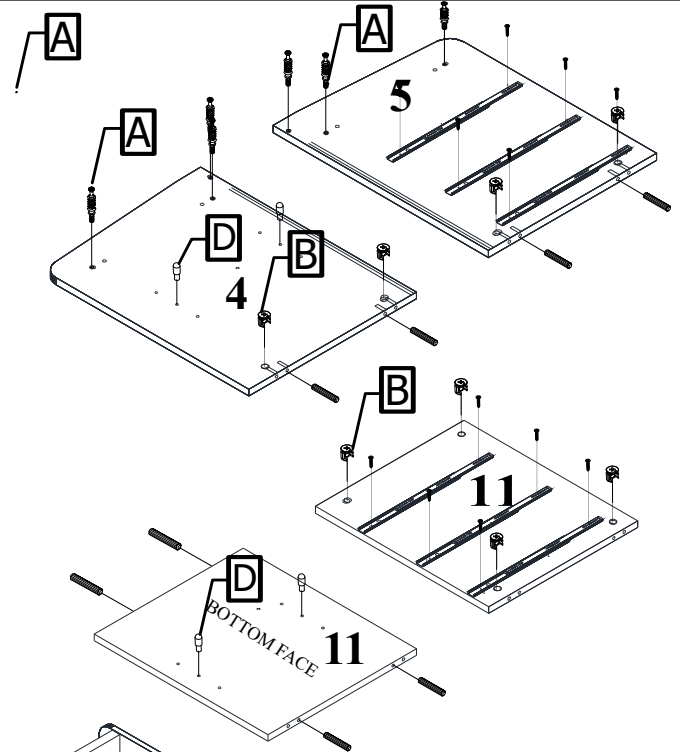
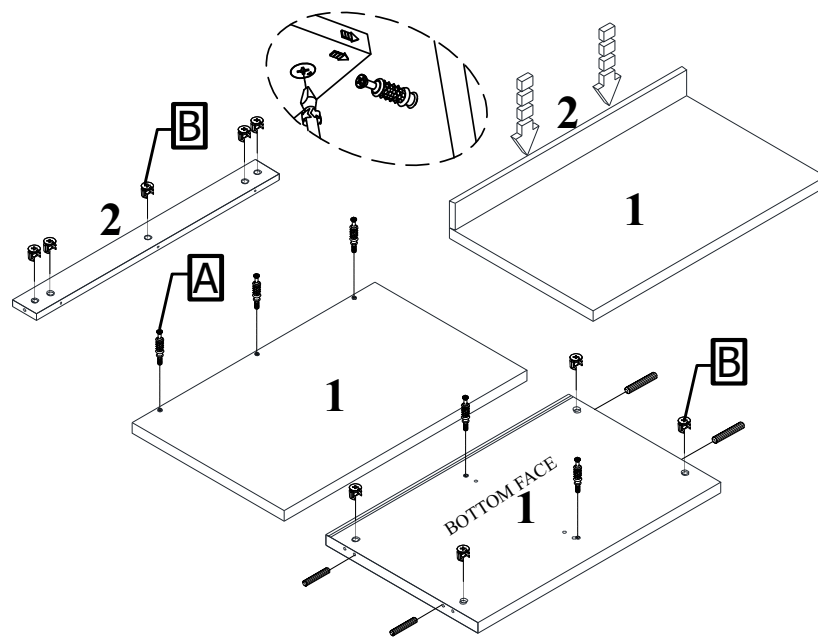
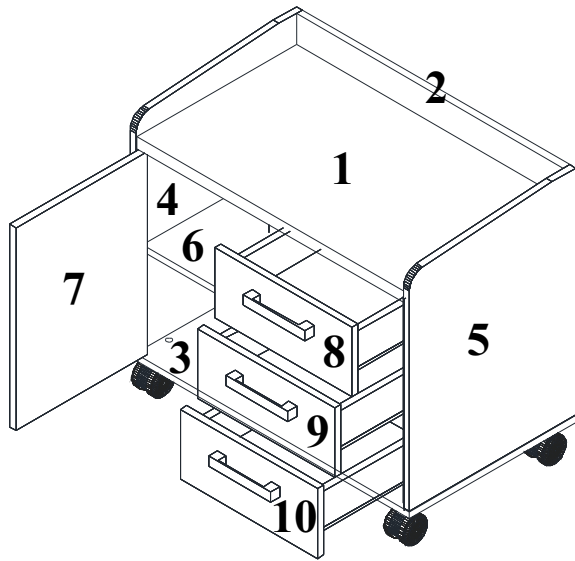

Part Code Quantity

Part Name

Part Number

A 17



MINIFIX STEEL SHAFT
102-001

B 17

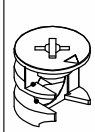

MINIFIX SCREW
102-002

C 12

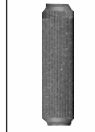

Ø8 x 30 PLS DOWEL
102-003

D 4



SHELF PIN (5 MM) (Y - 45)
102-004

E 4

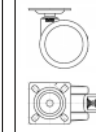

GREY BIG WHEEL
102-006

F 36

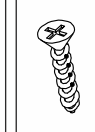

4*20 SCREWS
102-007

G 4

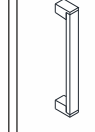

CHROME HANDLE 160 MM (Y-661)
102-008

H 8

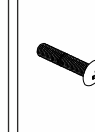

HANDLE SCREW M4*22 YHB (Y - 119)
102-009

I 1

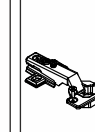

SOFT CLOSING FULL OVERLAY HINGE
102-010



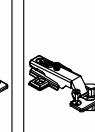



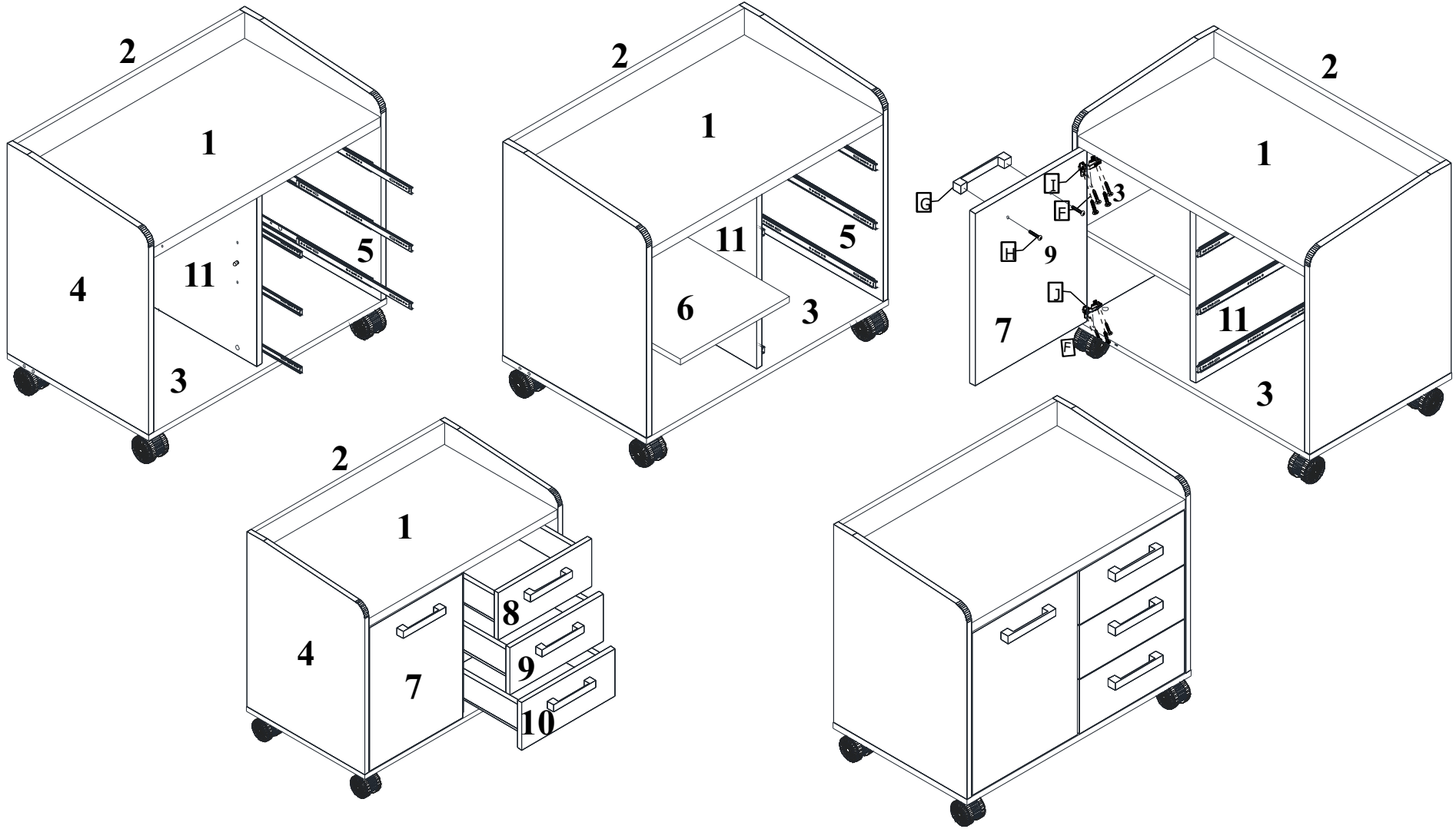

J 1



FULL OVERLAY HINGE
102-011

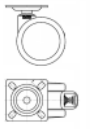



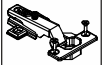

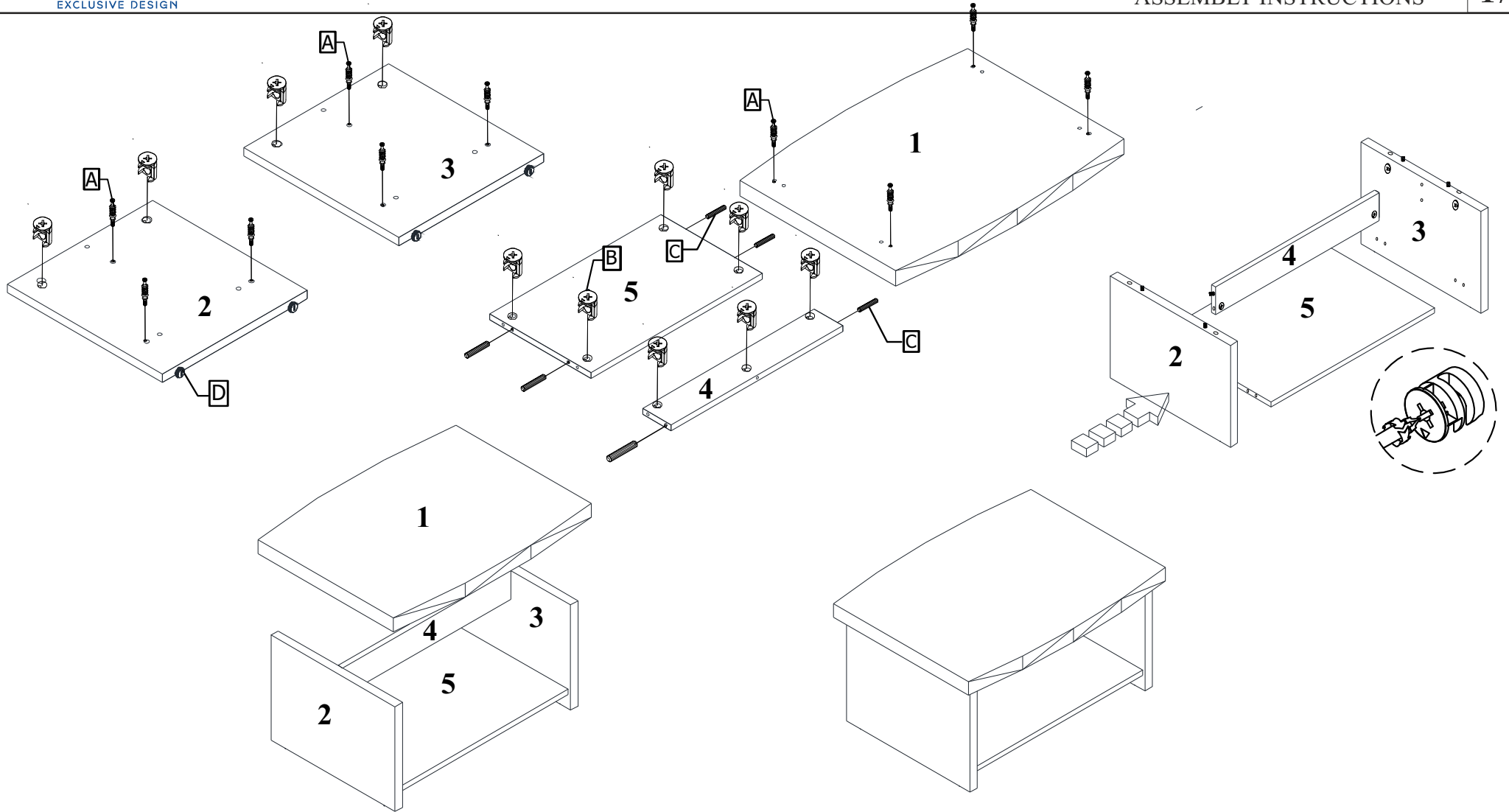

Part Code	Quantity	A	B	C	D	E	F	G	H	I	J						
		17	17	12	4	4	36	4	8	1	1						
Part Name																	
Part Number		102-001	102-002	102-003	102-004	102-006	102-007	102-008	102-009	102-010	102-011						





Part Code	Quantity	A	B	C	D												
																	
Part Name		MINIFIX STEEL SHAFT	MINIFIX SCREW	Ø8 x 30 PLS DOWEL	PINGO M6 (Y-166)												
Part Number		102-001	102-002	102-003	102-004												

